

W25P10, W25P20 AND W25P40



*spi*flash[®]

1M-BIT, 2M-BIT AND 4M-BIT SERIAL FLASH MEMORY WITH 40MHZ SPI



Formally NexFlash NX25P10, NX25P20 and NX25P40

The Winbond W25P10/20/40 are fully compatible with the previous NexFlash NX25P10/20/40 Serial Flash memories.

W25P10, W25P20 AND W25P40



Table of Contents-

| | | |
|--------|---|----|
| 1. | GENERAL DESCRIPTION | 4 |
| 2. | FEATURES | 4 |
| 3. | PIN CONFIGURATION | 5 |
| 4. | PIN DESCRIPTION..... | 5 |
| 4.1 | Package Types | 5 |
| 4.2 | Chip Select (/CS) | 5 |
| 4.3 | Serial Data Output (DO) | 6 |
| 4.4 | Write Protect (/WP)..... | 6 |
| 4.5 | HOLD (/HOLD) | 6 |
| 4.6 | Serial Clock (CLK) | 6 |
| 4.7 | Serial Data Input (DI) | 6 |
| 5. | BLOCK DIAGRAM | 7 |
| 6. | FUNCTIONAL DESCRIPTION | 8 |
| 6.1 | SPI OPERATIONS | 8 |
| 6.1.1 | SPI Modes..... | 8 |
| 6.1.2 | Hold Function | 8 |
| 6.2 | WRITE PROTECTION..... | 8 |
| 6.2.1 | Write Protect Features..... | 8 |
| 7. | CONTROL AND STATUS REGISTERS..... | 9 |
| 7.1 | STATUS REGISTER | 9 |
| 7.1.1 | BUSY..... | 9 |
| 7.1.2 | Write Enable Latch (WEL) | 9 |
| 7.1.3 | Block Protect Bits (BP2, BP1, BP0)..... | 10 |
| 7.1.4 | Reserved Bits | 10 |
| 7.1.5 | Status Register Protect (SRP)..... | 10 |
| 7.1.6 | Status Register Memory Protection | 11 |
| 7.2 | INSTRUCTIONS | 11 |
| 7.2.1 | Manufacturer and Device Identification..... | 12 |
| 7.2.2 | Instruction Set ⁽¹⁾ | 12 |
| 7.2.3 | Write Disable (04h)..... | 13 |
| 7.2.4 | Write Enable (06h)..... | 13 |
| 7.2.5 | Read Status Register (05h) | 14 |
| 7.2.6 | Write Status Register (01h) | 15 |
| 7.2.7 | Read Data (03h)..... | 16 |
| 7.2.8 | Fast Read (0Bh) | 17 |
| 7.2.9 | Page Program (02h)..... | 18 |
| 7.2.10 | Sector Erase (D8h)..... | 19 |

W25P10, W25P20 AND W25P40

| | | |
|--------|---|-----------|
| 7.2.11 | Chip Erase (C7h)..... | 20 |
| 7.2.12 | Power-down (B9h)..... | 21 |
| 7.2.13 | Release Power-down / Device ID (ABh)..... | 22 |
| 7.2.14 | Read Manufacturer / Device ID (90h)..... | 24 |
| 8. | ELECTRICAL CHARACTERISTICS..... | 25 |
| 8.1 | Absolute Maximum Ratings (1)..... | 25 |
| 8.2 | Operating Ranges..... | 25 |
| 8.3 | Power-up Timing and Write Inhibit Threshold..... | 26 |
| 8.4 | DC Electrical Characteristics (Preliminary)(1)..... | 27 |
| 8.5 | AC Measurement Conditions..... | 28 |
| 8.6 | AC Electrical Characteristics..... | 29 |
| 8.7 | AC Electrical Characteristics (cont'd)..... | 30 |
| 8.8 | Serial Output Timing..... | 31 |
| 8.9 | Input Timing..... | 31 |
| 8.10 | Hold Timing..... | 31 |
| 9. | PACKAGE SPECIFICATION..... | 32 |
| 9.1 | 8-Pin SOIC 150-mil (Winbond Package Code SN) (NexFlash Package Code N)..... | 32 |
| 10. | ORDERING INFORMATION..... | 33 |
| 11. | REVISION HISTORY..... | 34 |

W25P10, W25P20 AND W25P40



1. GENERAL DESCRIPTION

The W25P10 (1M-bit), W25P20 (2M-bit) and W25P40 (4M-bit) Serial Flash memories provide a storage solution for systems with limited space, pins and power. They are ideal for code download applications as well as storing voice, text and data. The devices operate on a single 2.7V to 3.6V power supply with current consumption as low as 4mA active and 1 μ A for power-down. All devices are offered in space-saving 8-pin SOIC type packages as shown below. Contact Winbond for availability of alternate packages. As part of a family of Serial Flash products, Winbond also provides a compatible migration path to 8M/16M/32M-bit densities.

The W25P10/20/40 array is organized into 512/1024/2048 programmable pages of 256-bytes each. A single byte or, up to 256 bytes, can be programmed at a time using the Page Program instruction. Pages are grouped into 2/4/8 erasable sectors of 256 pages (64K-byte) each as shown in figure 2. Both Sector Erase and Chip (full chip) Erase instructions are supported.

The Serial Peripheral Interface (SPI) consists of four pins (Serial Clock, Chip Select, Serial Data In and Serial Data Out) that support high speed serial data transfers up to 40MHz. A Hold pin, Write Protect pin and programmable write protect features provide further control flexibility. Additionally, the device can be queried for manufacturer and device ID. Special customer ID (for copy authentication) and factory programming is available, contact Winbond for more information.

The Winbond W25P10/20/40 are fully compatible with the previous NexFlash NX25P10/20/40 Serial Flash memories.

2. FEATURES

- **1M / 2M / 4M-bit Serial Flash Memories**
- **Family of Serial Flash Memories**
 - W25P10: 1M-bit/128K-byte (131,072)
 - W25P20: 2M-bit/256K-byte (262,144)
 - W25P40: 4M-bit/512K-byte (524,288)
 - 256-bytes per programmable page
 - Migration path to 8M/16M/32M-bit
- **4-pin SPI Serial Interface**
 - Clock, Chip Select, Data In, Data Out
 - Easily interfaces to popular microcontrollers
 - Compatible with SPI Modes 0 and 3
 - Bottom Boot organization (standard)
 - Optional Hold function for SPI flexibility
- **Low Power Consumption, Wide Temperature Range**
 - Single 2.7 to 3.6V supply
 - 4mA active current, 1 μ A Power-down (typ)
 - -40° to +85°C operating range
- **Fast and Flexible Serial Data Access**
 - 40MHz Fast Read, 33MHz Standard Read
 - Byte-addressable Read and Program
 - Auto-increment Read capability
 - Manufacturer and Device ID
- **Programming Features**
 - Page program up to 256 bytes <2ms
 - Sector Erase (64K-byte) 2 seconds
 - Chip erase: 3 seconds (25P10/20), 5 seconds (25P40)
 - 100,000 erase/write cycles
 - Twenty-year data retention
- **Software and Hardware Write Protection**
 - Write-Protect all or portion of memory
 - Enable/Disable protection with /WP pin
- **Space Saving Package**
 - Tiny 8-pin SOIC 150mil
- **Ideal for systems with limited pins, space, and power**
 - Controller-based serial code-download
 - μ C systems storing data, text or voice
 - Battery-operated and portable products

W25P10, W25P20 AND W25P40



3. PIN CONFIGURATION

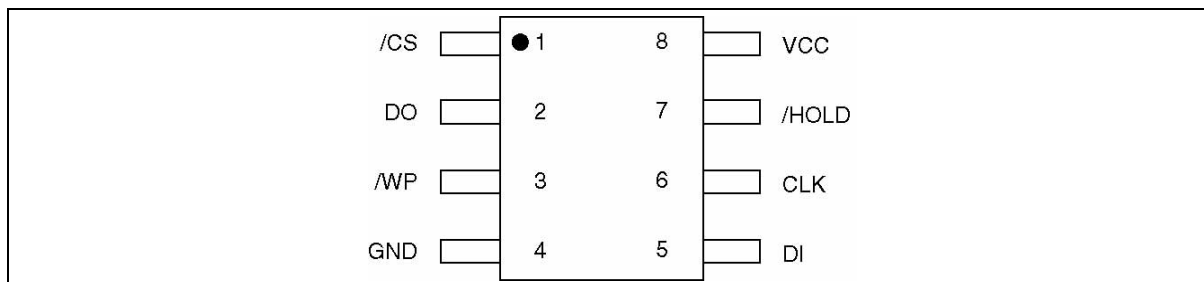

Figure 1. W25P10, W25P20 and W25P40 Pin Assignments, 8-pin SOIC 150-mil

4. PIN DESCRIPTION

| PIN NO. | PIN NAME | I/O | FUNCTION |
|---------|----------|-----|---------------------|
| 1 | /CS | I | Chip Select Input |
| 2 | DO | O | Data Output |
| 3 | /WP | I | Write Protect Input |
| 4 | GND | | Ground |
| 5 | DI | I | Data Input |
| 6 | CLK | I | Serial Clock Input |
| 7 | /HOLD | I | Hold Input |
| 8 | VCC | | Power Supply |

www.DataSheet4U.com

4.1 Package Types

The standard package for the W25P10/20/40 is an 8-pin plastic SOIC with 150-mil body (Winbond package code SN) (NexFlash package code N). It also allows a package migration path to higher density Serial Flash devices. The pinout for the package is shown in Figure 1. Package diagrams and dimensions are illustrated at the end of this data sheet. Optional 8-contact MLP packages may be available. Please contact Winbond for further MLP package information.

4.2 Chip Select (/CS)

The SPI Chip Select (/CS pin enables and disables device operation. When /CS is high the device is deselected and the Serial Data Output (DO) pin is at high impedance. When deselected, the devices power consumption will be at standby levels unless an internal erase, program or status register cycle is in progress. When /CS is brought low the device will be selected, power consumption will increase to active levels and instructions can be written to and data read from the device. After power-up, /CS must transition from high to low before a new instruction will be accepted. The /CS input must track

W25P10, W25P20 AND W25P40



the VCC supply level at power-up (see "Write Protection" and figure 16). If needed a pull-up resistor on /CS can be used to accomplish this.

4.3 Serial Data Output (DO)

The SPI Serial Data Output (DO) pin provides a means for data and status to be serially read from (shifted out of) the device. Data is shifted out on the falling edge of the Serial Clock (CLK) input pin.

4.4 Write Protect (/WP)

The Write Protect (/WP) pin can be used to prevent the Status Register from being written. Used in conjunction with the Status Register's Block Protect (BP2, BP1, and BP0) bits and Status Register Protect (SRP) bits, a portion or the entire memory array can be hardware protected. The /WP pin is active low.

4.5 HOLD (/HOLD)

The /HOLD pin allows the device to be paused while it is actively selected. When /HOLD is brought low, while /CS is low, the DO pin will be at high impedance and signals on the DI and CLK pins will be ignored (don't care). When /HOLD is brought high, device operation can resume. The /HOLD function can be useful when multiple devices are sharing the same SPI signals. ("See Hold function")

4.6 Serial Clock (CLK)

The SPI Serial Clock Input (CLK) pin provides the timing for serial input and output operations. ("See SPI "Operations")

www.DataSheet4U.com

4.7 Serial Data Input (DI)

The SPI Serial Data Input (DI) pin provides a means for instructions, addresses and data to be serially written to (shifted into) the device. Data is latched on the rising edge of the Serial Clock (CLK) input pin.

W25P10, W25P20 AND W25P40



5. BLOCK DIAGRAM

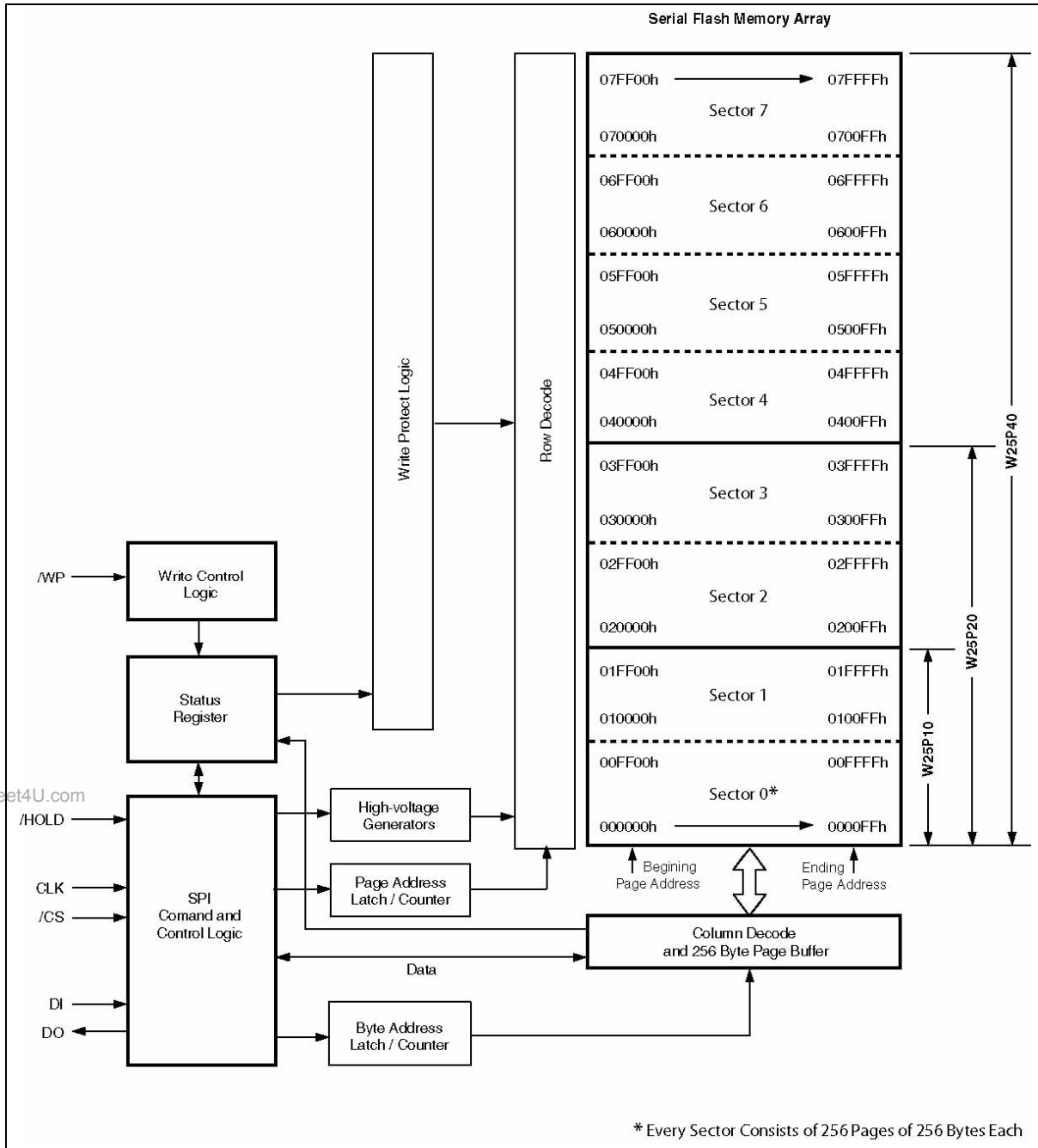

Figure 2. W25P10, W25P20 and W25P40 Block Diagram

W25P10, W25P20 AND W25P40



6. FUNCTIONAL DESCRIPTION

6.1 SPI OPERATIONS

6.1.1 SPI Modes

The W25P10/20/40 is accessed through an SPI compatible bus consisting of four signals: Serial Clock (CLK), Chip Select (/CS), Serial Data Input (DI) and Serial Data Output (DO). Both SPI bus operation Modes 0 (0,0) and 3 (1,1) are supported. The primary difference between Mode 0 and Mode 3 concerns the normal state of the CLK signal when the SPI bus master is in standby and data is not being transferred to the Serial Flash. For Mode 0 the CLK signal is normally low. For Mode 3 the CLK signal is normally high. In either case data input on the DI pin is sampled on the rising edge of the CLK. Data output on the DO pin is clocked out on the falling edge of CLK.

6.1.2 Hold Function

The /HOLD signal allows the W25P10/20/40 operation to be paused while it is actively selected (when /CS is low). The /HOLD function may be useful in cases where the SPI data and clock signals are shared with other devices. For example, consider if the page buffer was only partially written when a priority interrupt requires use of the SPI bus. In this case the /HOLD function can save the state of the instruction and the data in the buffer so programming can resume where it left off once the bus is available again.

To initiate a /HOLD condition, the device must be selected with /CS low. A /HOLD condition will activate on the falling edge of the /HOLD signal if the CLK signal is already low. If the CLK is not already low the /HOLD condition will activate after the next falling edge of CLK. The /HOLD condition will terminate on the rising edge of the /HOLD signal if the CLK signal is already low. If the CLK is not already low the /HOLD condition will terminate after the next falling edge of CLK.

During a /HOLD condition, the Serial Data Output (DO) is high impedance, and Serial Data Input (DI) and Serial Clock (CLK) are ignored. The Chip Select (/CS) signal should be kept active (low) for the full duration of the /HOLD operation to avoid resetting the internal logic state of the device.

6.2 WRITE PROTECTION

Applications that use non-volatile memory must take into consideration the possibility of noise and other adverse system conditions that may compromise data integrity. To address this concern the W25P10/20/40 provides several means to protect data from inadvertent writes.

6.2.1 Write Protect Features

- Device resets when VCC is below threshold.
- Time delay write disable after Power-up.
- Write enable/disable instructions.
- Automatic write disable after program and erase.
- Software write protection using Status Register.
- Hardware write protection using Status Register and /WP pin.
- Write Protection using Power-down instruction.

W25P10, W25P20 AND W25P40



Upon power-up or at power-down the W25P10/20/40 will maintain a reset condition while VCC is below the threshold value of V_{WI} , (See Power-up Timing and Voltage Levels and Figure 17). While reset, all operations are disabled and no instructions are recognized. During power-up and after the VCC voltage exceeds V_{WI} , all program and erase related instructions are further disabled for a time delay of t_{PUW} . This includes the Write Enable, Page Program, Sector Erase, Chip Erase and the Write Status Register instructions. Note that the chip select pin (/CS) must track the VCC supply level at power-up until the VCC-min level and t_{VSL} time delay is reached. If needed a pull-up resistor on /CS can be used to accomplish this.

After power-up the device is automatically placed in a write-disabled state with the Status Register Write Enable Latch (WEL) set to a 0. A Write Enable instruction must be issued before a Page Program, Sector Erase, Chip Erase or Write Status Register instruction will be accepted. After completing a program, erase or write instruction the Write Enable Latch (WEL) is automatically cleared to a write-disabled state of 0.

Software controlled write protection is facilitated using the Write Status Register instruction and setting the Status Register Protect (SRP) and Block Protect (BP2, BP1, and BP0) bits. These Status Register bits allow a portion or all of the memory to be configured as read only. Used in conjunction with the Write Protect (/WP) pin, changes to the Status Register can be enabled or disabled under hardware control. See Status Register for further information.

Additionally, the Power-down instruction offers an extra level of write protection as all instructions are ignored except for the Release Power-down instruction.

7. CONTROL AND STATUS REGISTERS

The Read Status Register instruction can be used to provide status on the availability of the Flash memory array, if the device is write enabled or disabled, and the state of write protection. The Write Status Register instruction can be used to configure the devices write protection features. See Figure

3

www.DataSheet4U.com

7.1 STATUS REGISTER

7.1.1 BUSY

BUSY is a read only bit in the status register (S0) that is set to a 1 state when the device is executing a Page Program, Sector Erase, Chip Erase or Write Status Register instruction. During this time the device will ignore further instructions except for the Read Status Register instruction (see t_W , t_{PP} , t_{SE} and t_{CE} in AC Characteristics). When the program, erase or write status register instruction has completed, the BUSY bit will be cleared to a 0 state indicating the device is ready for further instructions.

7.1.2 Write Enable Latch (WEL)

Write Enable Latch (WEL) is a read only bit in the status register (S1) that is set to a 1 after executing a Write Enable Instruction. The WEL status bit is cleared to a 0 when the device is write disabled. A

W25P10, W25P20 AND W25P40



write disable state occurs upon power-up or after any of the following instructions: Write Disable, Page Program, Sector Erase, Chip Erase and Write Status Register.

7.1.3 Block Protect Bits (BP2, BP1, BP0)

The Block Protect Bits (BP2, BP1, BP0) are non-volatile read/write bits in the status register (S4, S3, S2) that provide Write Protection control and status. Block Protect bits can be set using the Write Status Register Instruction (see tW in AC characteristics). All, none or a portion of the memory array can be protected from Program and Erase instructions (see Status Register Memory Protection table). The factory default setting for the Block Protection Bits is 0, none of the array protected. The Block Protect bits can not be written to if the Status Register Protect (SRP) bit is set to 1 and the Write Protect (/WP) pin is low. The W25P20 and W25P10 do not use BP2.

7.1.4 Reserved Bits

Status register bit locations 5 and 6 are reserved for future use. Current devices will read 0 for these bit locations. It is recommended to mask out the reserved bit when testing the Status Register. Doing this will ensure compatibility with future devices.

7.1.5 Status Register Protect (SRP)

The Status Register Protect (SRP) bit is a non-volatile read/write bit in the status register (S7) that can be used in conjunction with the Write Protect (/WP) pin to disable writes to the status register. When the SRP bit is set to a 0 state (factory default) the /WP pin has no control over the status register. When the SRP pin is set to a 1, the Write Status Register instruction is locked out while the /WP pin is low. When the /WP pin is high the Write Status Register instruction is allowed.

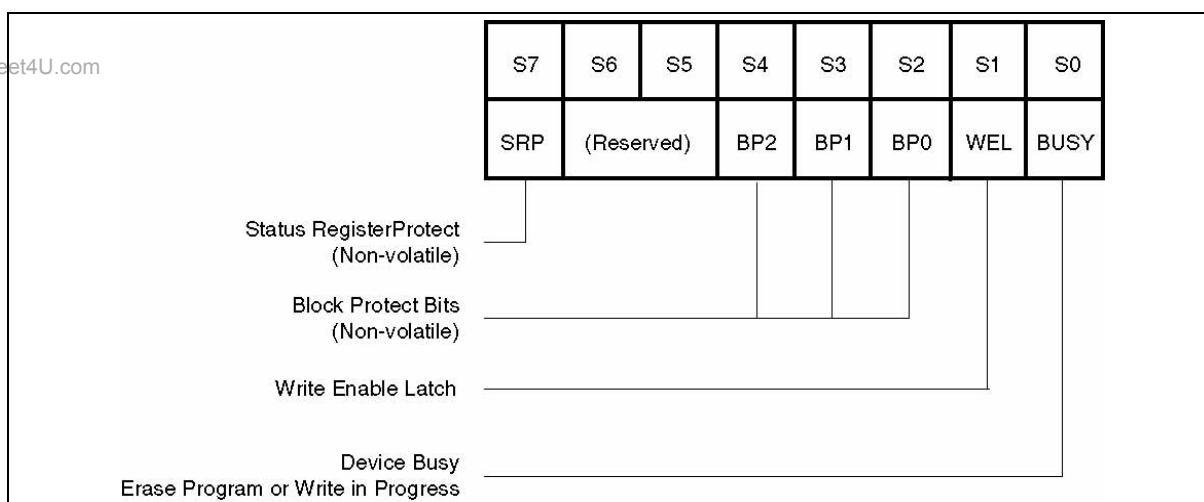

Figure 3. Status Register Bit Locations

W25P10, W25P20 AND W25P40



7.1.6 Status Register Memory Protection

| STATUS REGISTER ⁽¹⁾ | | | W25P40 (4M-BIT) MEMORY PROTECTION | | | |
|--------------------------------|-----|-----|-----------------------------------|-------------------|--------------|-----------|
| BP2 | BP1 | BP0 | SECTOR(S) | ADDRESSES | DENSITY (KB) | PORTION |
| 0 | 0 | 0 | NONE | NONE | NONE | NONE |
| 0 | 0 | 1 | 7 | 070000h - 07FFFFh | 512K-bit | Upper 1/8 |
| 0 | 1 | 0 | 6 and 7 | 060000h - 07FFFFh | 1M-bit | Upper 1/4 |
| 0 | 1 | 1 | 4 thru 7 | 040000h - 07FFFFh | 2M-bit | Upper 1/2 |
| 1 | x | x | ALL | 000000h - 07FFFFh | 4M-bit | ALL |

| STATUS REGISTER ⁽¹⁾ | | | W25P20 (2M-BIT) MEMORY PROTECTION | | | |
|--------------------------------|-----|-----|-----------------------------------|-------------------|--------------|-----------|
| BP2 | BP1 | BP0 | SECTOR(S) | ADDRESSES | DENSITY (KB) | PORTION |
| x | 0 | 0 | NONE | NONE | NONE | NONE |
| x | 0 | 1 | 3 | 030000h - 03FFFFh | 512K-bit | Upper 1/4 |
| x | 1 | 0 | 2 and 3 | 020000h - 03FFFFh | 1M-bit | Upper 1/2 |
| x | 1 | 1 | ALL | 000000h - 03FFFFh | 2M-bit | ALL |

| STATUS REGISTER ⁽¹⁾ | | | W25P10 (1M-BIT) MEMORY PROTECTION | | | |
|--------------------------------|-----|-----|-----------------------------------|-------------------|--------------|---------|
| BP2 | BP1 | BP0 | SECTOR(S) | ADDRESSES | DENSITY (KB) | PORTION |
| x | 0 | x | NONE | NONE | NONE | NONE |
| x | 1 | 0 | NONE | NONE | NONE | NONE |
| x | 1 | 1 | ALL | 000000h - 01FFFFh | 1M-bit | ALL |

Note:

1. x = don't care

7.2 INSTRUCTIONS

The instruction set of the W25P10/20/40 consists of twelve basic instructions that are fully controlled through the SPI bus (see Instruction Set table). Instructions are initiated with the falling edge of Chip Select (/CS). The first byte of data clocked into the DI input provides the instruction code. Data on the DI input is sampled on the rising edge of clock with most significant bit (MSB) first.

Instructions vary in length from a single byte to several bytes and may be followed by address bytes, data bytes, dummy bytes (don't care), and in some cases, a combination. Instructions are completed with the rising edge of edge /CS. Clock relative timing diagrams for each instruction are included in figures 4 through 16. All read instructions can be completed after any clocked bit. However, all instructions that Write, Program or Erase must complete on a byte boundary (/CS driven high after a full 8-bits have been clocked) otherwise the instruction will be terminated. This feature further protects the device from inadvertent writes. Additionally, while the memory is being programmed or erased, or when the Status Register is being written, all instructions except for Read Status Register will be ignored until the program or erase cycle has completed.

W25P10, W25P20 AND W25P40



7.2.1 Manufacturer and Device Identification

| | |
|------------------------|------------------|
| MANUFACTURER ID | (M7-M0) |
| Winbond Serial Flash | EFH |
| Device ID | (ID7-ID0) |
| W25P10 | 10h |
| W25P20 | 11h |
| W25P40 | 12h |

7.2.2 Instruction Set ⁽¹⁾

| INSTRUCTION NAME | BYTE 1 CODE | BYTE 2 ⁽⁵⁾ | BYTE 3 | BYTE 4 | BYTE 5 | BYTE 6 | N-BYTES |
|--------------------------------|-------------|------------------------|--------|----------------------|-----------|-------------|------------------------|
| Write Enable | 06h | | | | | | |
| Write Disable | 04h | | | | | | |
| Read Status Register | 05h | (S7-S0) ⁽¹⁾ | | | | | (2) |
| Write Status Register | 01h | S7-S0 | | | | | |
| Read Data | 03h | A23-A16 | A15-A8 | A7-A0 | (D7-D0) | (Next byte) | continuous |
| Fast Read | 0Bh | A23-A16 | A15-A8 | A7-A0 | dummy | (D7-D0) | (Next Byte) continuous |
| Page Program | 02h | A23-A16 | A15-A8 | A7-A0 | (D7-D0) | (Next byte) | up to 256 bytes |
| Sector Erase | D8h | A23-A16 | A15-A8 | A7-A0 ⁽⁶⁾ | | | |
| Chip Erase | C7h | | | | | | |
| Power-down | B9h | | | | | | |
| Release Power-down / Device ID | ABh | dummy | dummy | dummy | (ID7-ID0) | | (3) |
| Manufacturer/ Device ID | 90h | dummy | dummy | 00h | (M7-M0) | (ID7-ID0) | (4) |

Notes:

1. Data bytes are shifted with Most Significant Bit first. Byte fields with data in parenthesis “()” indicate data being read from the device on the DO pin.
2. The Status Register contents will repeat continuously until /CS terminates the instruction.
3. The Device ID will repeat continuously until /CS terminates the instruction.
4. The Manufacturer ID and Device ID bytes will repeat continuously until /CS terminates the instruction.
5. Unused upper address bits must be set to a 0 for the W25P10.
6. The lowest 16 address bits (A15-A0) must be set to 0.

W25P10, W25P20 AND W25P40



7.2.3 Write Disable (04h)

The Write Enable instruction (Figure 4) sets the Write Enable Latch (WEL) bit in the Status Register to a 1. The WEL bit must be set prior to every Page Program, Sector Erase, Chip Erase and Write Status Register instruction. The Write Enable instruction is entered by driving /CS low, shifting the instruction code "06h" into the Data Input (DI) pin on the rising edge of CLK, and then driving /CS high.

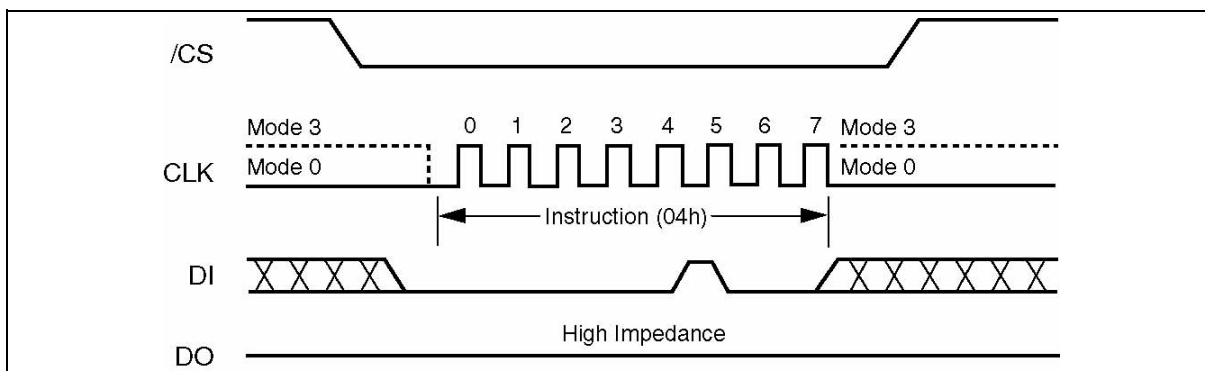

Figure 4. Write Disable Instruction Sequence Diagram

7.2.4 Write Enable (06h)

The Write Disable instruction (Figure 5) resets the Write Enable Latch (WEL) bit in the Status Register to a 0. The Write Disable instruction is entered by driving /CS low, shifting the instruction code "04h" into the DI pin and then driving /CS high. Note that the WEL bit is automatically reset after Power-up and upon completion of the Write Status Register, Page Program, Sector Erase, and Chip Erase instructions.

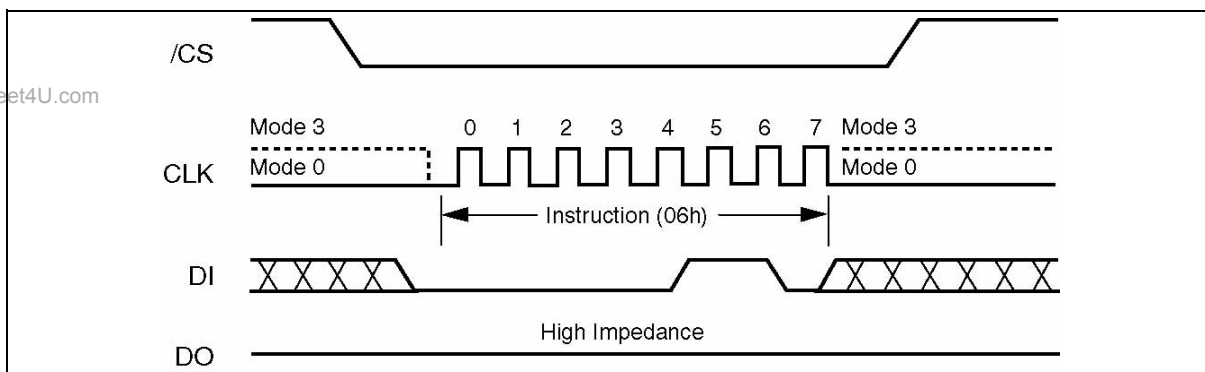

Figure 5. Write Enable Instruction Sequence Diagram

W25P10, W25P20 AND W25P40



7.2.5 Read Status Register (05h)

The Read Status Register instruction allows the 8-bit Status Register to be read. The instruction is entered by driving /CS low and shifting the instruction code “05h” into the DI pin on the rising edge of CLK. The status register bits are then shifted out on the DO pin at the falling edge of CLK with most significant bit (MSB) first as shown in figure 6. The Status Register bits are shown in figure 3 and include the BUSY, WEL, BP2-BP0, and SRP bits (see description of the Status Register earlier in this data sheet).

The Status Register instruction may be used at any time, even while a Program, Erase or Write Status Register cycle is in progress. This allows the BUSY status bit to be checked to determine when the cycle is complete and if the device can accept another instruction. The Status Register can be read continuously, as shown in Figure 6. The instruction is completed by driving /CS high.

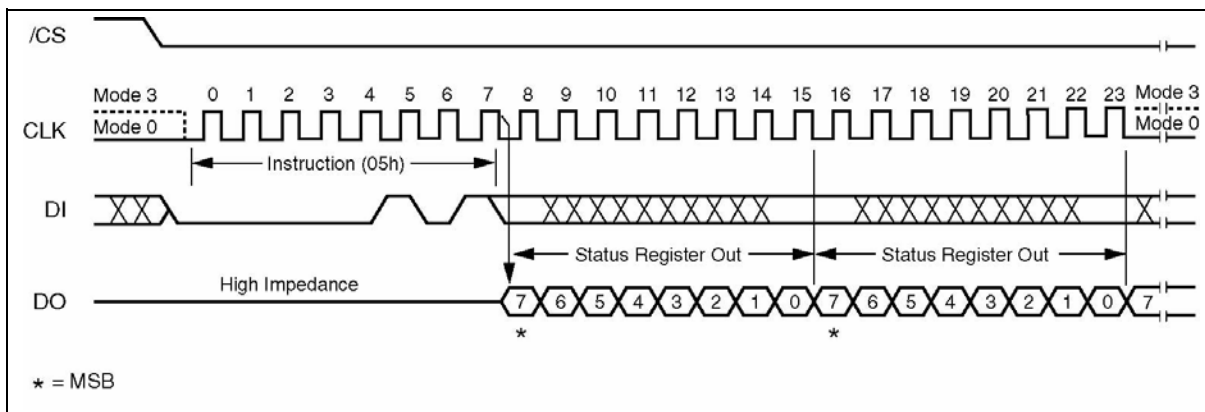

Figure 6. Read Status Register Instruction Sequence Diagram

W25P10, W25P20 AND W25P40



7.2.6 Write Status Register (01h)

The Write Status Register instruction allows the Status Register to be written. A Write Enable instruction must previously have been executed for the device to accept the Write Status Register Instruction (Status Register bit WEL must equal 1). Once write enabled, the instruction is entered by driving /CS low, sending the instruction code "01h", and then writing the status register data byte as illustrated in figure 7. The Status Register bits are shown in figure 3 and described earlier in this data sheet.

Only non-volatile Status Register bits SRP, BP2, BP1 and BP0 (bits 7, 4, 3 and 2) can be written to. All other Status Register bit locations are read-only and will not be affected by the Write Status Register instruction.

The /CS pin must be driven high after the eighth bit of the last byte has been latched. If this is not done the Write Status Register instruction will not be executed. After /CS is driven high, the self-timed Write Status Register cycle will commence for a time duration of t_w (See AC Characteristics). While the Write Status Register cycle is in progress, the Read Status Register instruction may still be accessed to check the status of the BUSY bit. The BUSY bit is a 1 during the Write Status Register cycle and a 0 when the cycle is finished and ready to accept other instructions again. After the Write Register cycle has finished the Write Enable Latch (WEL) bit in the Status Register will be cleared to 0.

The Write Status Register instruction allows the Block Protect bits (BP2, BP1 and BP0) to be set for protecting all, a portion, or none of the memory from erase and program instructions. Protected areas become read-only (see Status Register Memory Protection table). The Write Status Register instruction also allows the Status Register Protect bit (SRP) to be set. This bit is used in conjunction with the Write Protect (/WP) pin to disable writes to the status register. When the SRP bit is set to a 0 state (factory default) the /WP pin has no control over the status register. When the SRP pin is set to a 1, the Write Status Register instruction is locked out while the /WP pin is low. When the /WP pin is high the Write Status Register instruction is allowed.

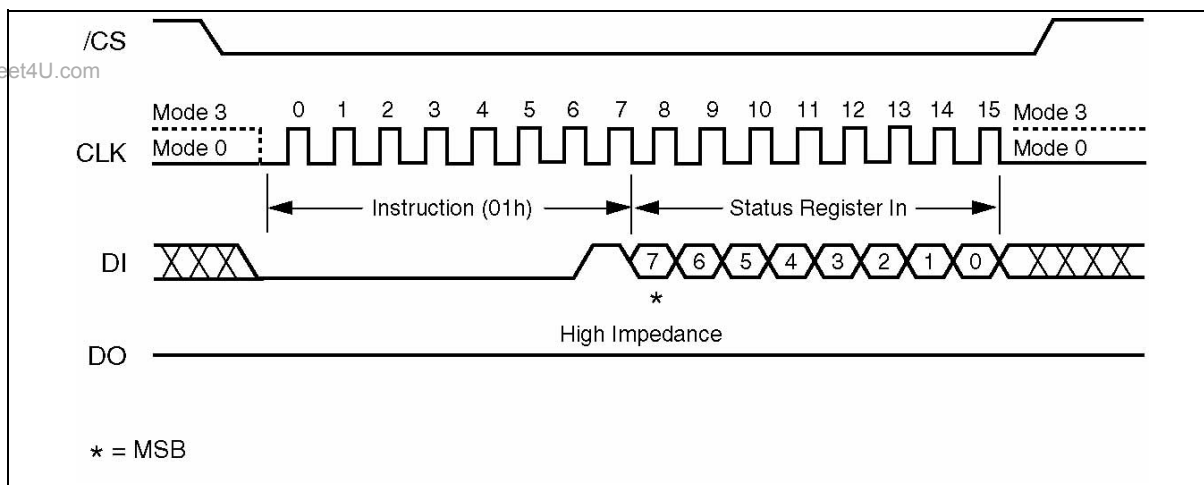

Figure 7. Write Status Register Instruction Sequence Diagram

W25P10, W25P20 AND W25P40



7.2.7 Read Data (03h)

The Read Data instruction allows one or more data bytes to be sequentially read from the memory. The instruction is initiated by driving the /CS pin low and then shifting the instruction code “03h” followed by a 24-bit address (A23-A0) into the DI pin. The code and address bits are latched on the rising edge of the CLK pin. After the address is received, the data byte of the addressed memory location will be shifted out on the DO pin at the falling edge of CLK with most significant bit (MSB) first. The address is automatically incremented to the next higher address after each byte of data is shifted out allowing for a continuous stream of data. This means that the entire memory can be accessed with a single instruction as long as the clock continues. The instruction is completed by driving /CS high. The Read Data instruction sequence is shown in figure 8. If a Read Data instruction is issued while an Erase, Program or Write cycle is in process (BUSY=1) the instruction is ignored and will not have any effects on the current cycle. The Read Data instruction allows clock rates from D.C. to a maximum of f_R (see AC Electrical Characteristics).

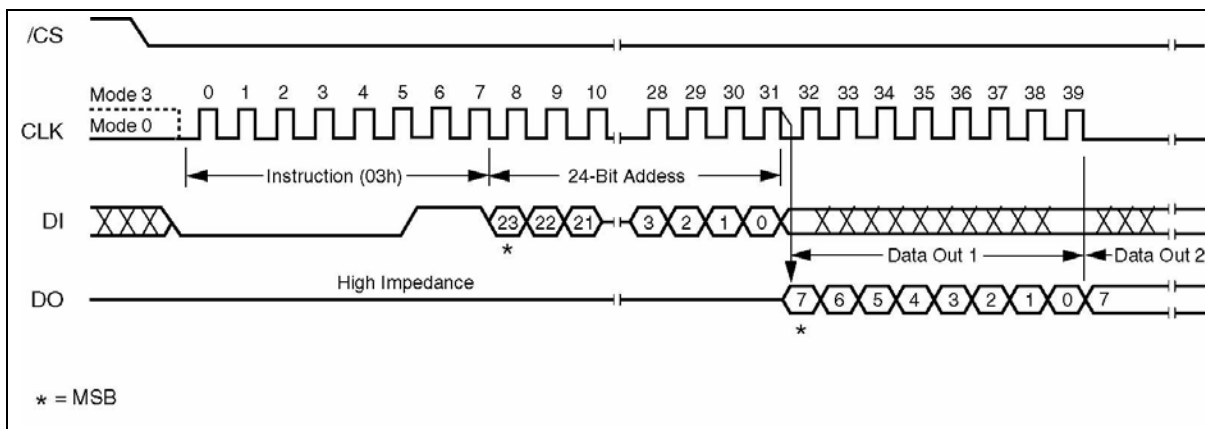

Figure 8. Read Data Instruction Sequence Diagram

W25P10, W25P20 AND W25P40



7.2.8 Fast Read (0Bh)

The Fast Read instruction is similar to the Read Data instruction except that it can operate at the highest possible frequency of FR (see AC Electrical Characteristics). This is accomplished by adding a “dummy” byte after the 24-bit address as shown in figure 9. The dummy byte allows the devices internal circuits additional time for setting up the initial address. The dummy byte data value on the DI pin is a “don’t care”.

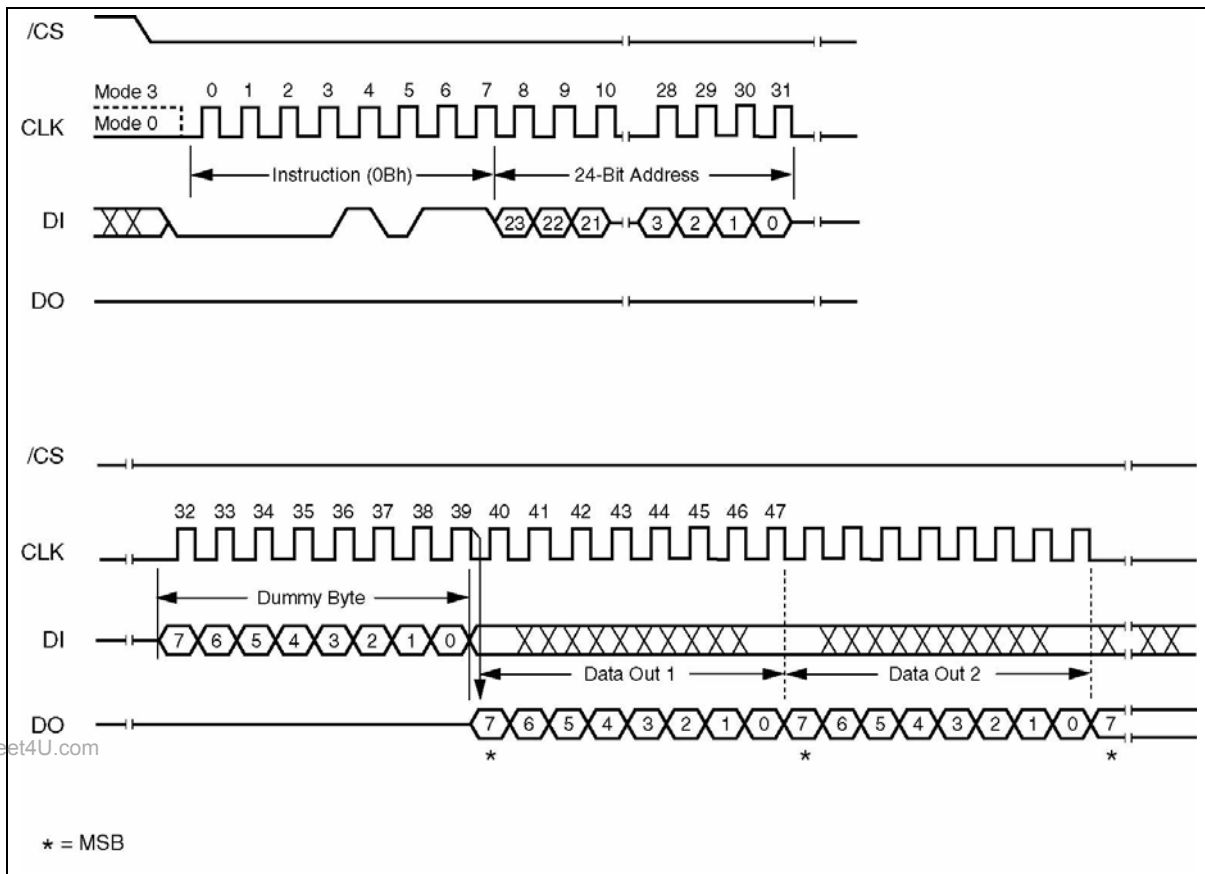

Figure 9. Fast Read Instruction Sequence Diagram

W25P10, W25P20 AND W25P40



7.2.9 Page Program (02h)

The Page Program instruction allows from one byte to 256 bytes of data to be programmed at memory locations previously erased to all 1s (FFh). A Write Enable instruction must be executed before the device will accept the Page Program Instruction (Status Register bit WEL must equal 1). The instruction is initiated by driving the /CS pin low then shifting the instruction code "02h" followed by a 24-bit address (A23-A0) and at least one data byte, into the DI pin. The /CS pin must be driven low for the entire length of the instruction while data is being sent to the device. The Page Program instruction sequence is shown in figure 10.

If an entire 256 byte page is to be programmed, the last address byte (the 8 least significant address bits) should be set to 0. If the last address byte is not zero, and the number of clocks exceed the remaining page length, the addressing will wrap to the beginning of the page. Less than 256 bytes can be programmed without having any effect on other bytes within the same page. If more than 256 bytes are sent to the device the addressing will wrap to the beginning of the page and overwrite previously sent data.

As with the write and erase instructions, the /CS pin must be driven high after the eighth bit of the last byte has been latched. If this is not done the Page Program instruction will not be executed. After /CS is driven high, the self-timed Page Program instruction will commence for a time duration of t_{pp} (See AC Characteristics). While the Page Program cycle is in progress, the Read Status Register instruction may still be accessed for checking the status of the BUSY bit. The BUSY bit is a 1 during the Page Program cycle and becomes a 0 when the cycle is finished and the device is ready to accept other instructions again. After the Page Program cycle has finished the Write Enable Latch (WEL) bit in the Status Register is cleared to 0. The Page Program instruction will not be executed if the addressed page is protected by the Block Protect (BP2, BP1, BP0) bits (see Status Register Memory Protection table).

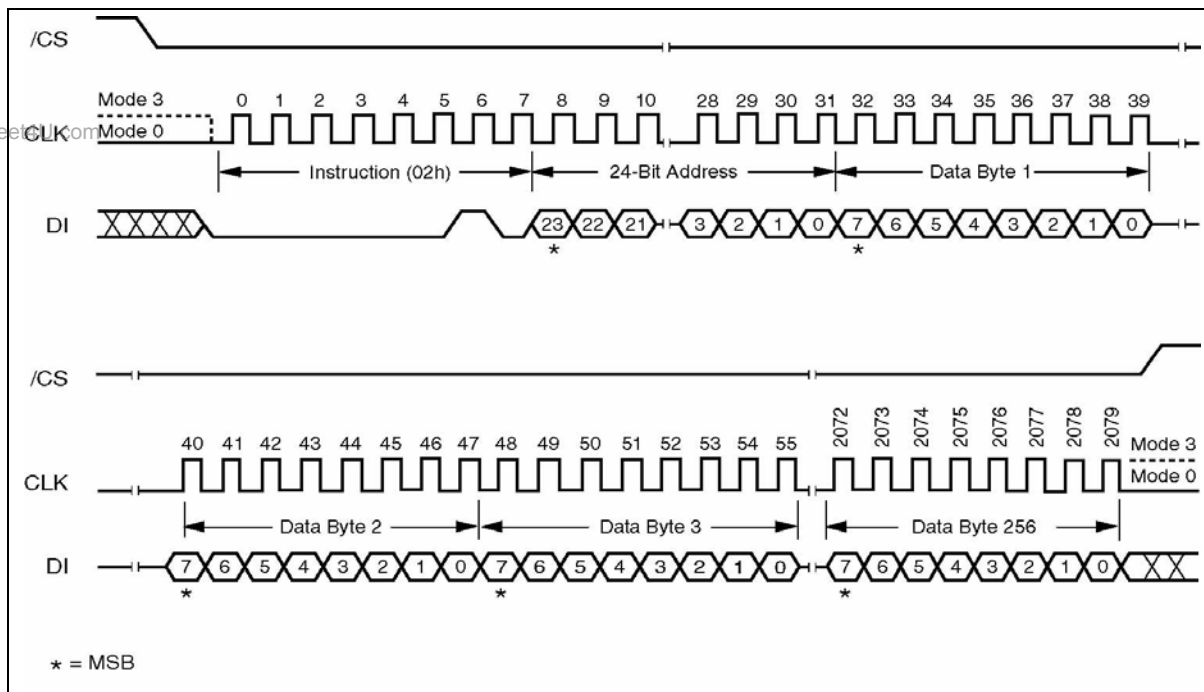

Figure 10. Page Program Instruction Sequence Diagram

W25P10, W25P20 AND W25P40



7.2.10 Sector Erase (D8h)

The Sector Erase instruction sets all memory within a specified sector to the erased state of all 1s (FFh). A Write Enable instruction must be executed before the device will accept the Erase Sector Instruction (Status Register bit WEL must equal 1). The instruction is initiated by driving the /CS pin low and shifting the instruction code "D8h" followed a 24-bit sector address (A23-A0) (see Figure 2). The lowest 16 address bits (A15-A0) must be set to 0. The Sector Erase instruction sequence is shown in figure 11.

The /CS pin must be driven high after the eighth bit of the last byte has been latched. If this is not done the Sector Erase instruction will not be executed. After /CS is driven high, the self-timed Sector Erase instruction will commence for a time duration of tSE (See AC Characteristics). While the Sector Erase cycle is in progress, the Read Status Register instruction may still be accessed for checking the status of the BUSY bit. The BUSY bit is a 1 during the Sector Erase cycle and becomes a 0 when the cycle is finished and the device is ready to accept other instructions again. After the Sector Erase cycle has finished the Write Enable Latch (WEL) bit in the Status Register is cleared to 0. The Sector Erase instruction will not be executed if the addressed page is protected by the Block Protect (BP2, BP1, BP0) bits (see Status Register Memory Protection table).

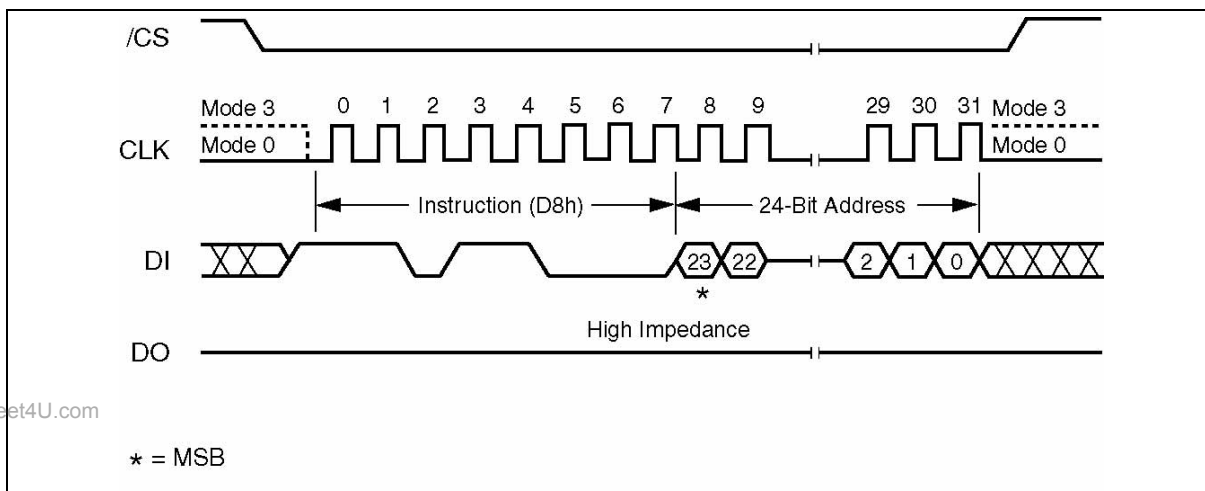

Figure 11. Sector Erase Instruction Sequence Diagram

W25P10, W25P20 AND W25P40



7.2.11 Chip Erase (C7h)

The Chip Erase instruction sets all memory within the device to the erased state of all 1s (FFh). A Write Enable instruction must be executed before the device will accept the Chip Erase Instruction (Status Register bit WEL must equal 1). The instruction is initiated by driving the /CS pin low and shifting the instruction code "C7h". The Chip Erase instruction sequence is shown in figure 12.

The /CS pin must be driven high after the eighth bit has been latched. If this is not done the Chip Erase instruction will not be executed. After /CS is driven high, the self-timed Chip Erase instruction will commence for a time duration of tCE (See AC Characteristics). While the Chip Erase cycle is in progress, the Read Status Register instruction may still be accessed to check the status of the BUSY bit. The BUSY bit is a 1 during the Chip Erase cycle and becomes a 0 when finished and the device is ready to accept other instructions again. After the Chip Erase cycle has finished the Write Enable Latch (WEL) bit in the Status Register is cleared to 0. The Chip Erase instruction will not be executed if any page is protected by the Block Protect (BP2, BP1, BP0) bits (see Status Register Memory Protection table).

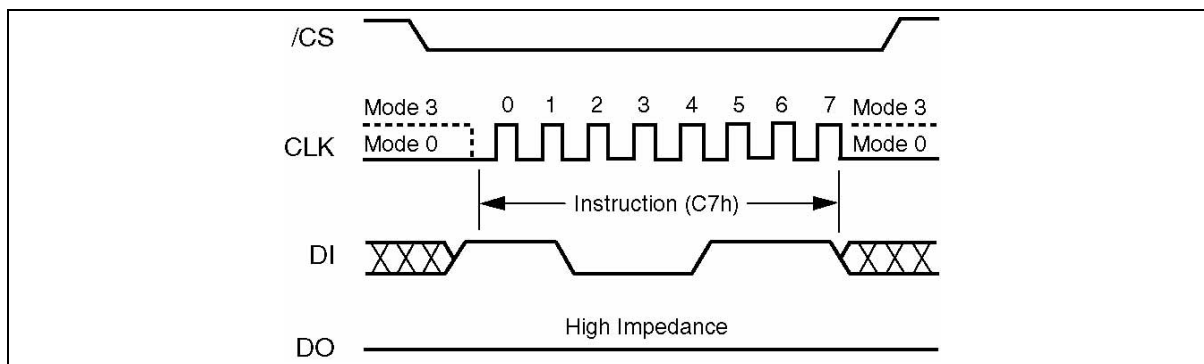

Figure 12. Chip Erase Instruction Sequence Diagram

W25P10, W25P20 AND W25P40



7.2.12 Power-down (B9h)

Although the standby current during normal operation is relatively low, standby current can be further reduced with the Power-down instruction. The lower power consumption makes the Power-down instruction especially useful for battery powered applications (See ICC1 and ICC2 in AC Characteristics). The instruction is initiated by driving the /CS pin low and shifting the instruction code "B9h" as shown in figure 13.

The /CS pin must be driven high after the eighth bit has been latched. If this is not done the Power-down instruction will not be executed. After /CS is driven high, the power-down state will be entered within the time duration of tDP (See AC Characteristics). While in the power-down state only the Release from Power-down / Device ID instruction, which restores the device to normal operation, will be recognized. All other instructions are ignored. This includes the Read Status Register instruction, which is always available during normal operation. Ignoring all but one instruction makes the Power Down state a useful condition for securing maximum write protection. The device always powers-up in the normal operation with the standby current of ICC1.

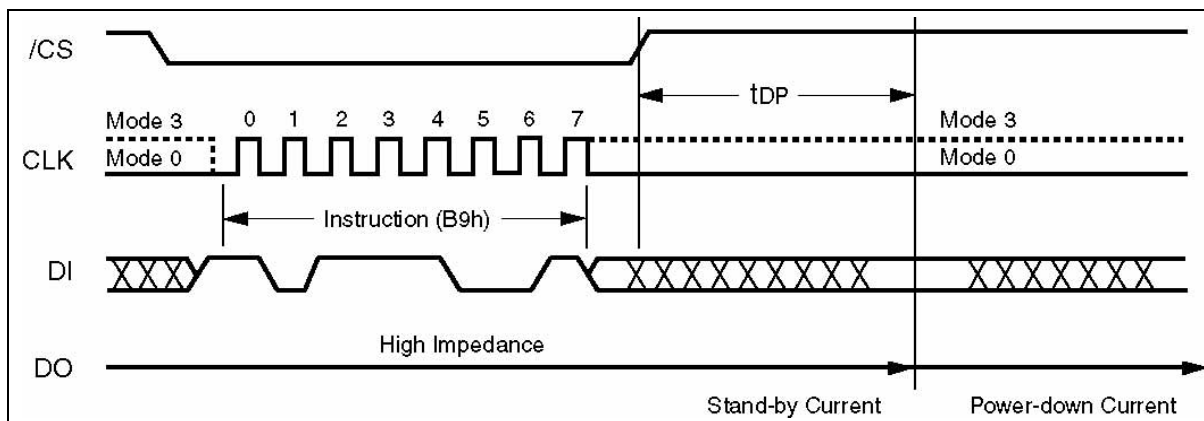

Figure 13. Deep Power-down Instruction Sequence Diagram

W25P10, W25P20 AND W25P40



7.2.13 Release Power-down / Device ID (ABh)

The Release from Power-down / Device ID instruction is a multi-purpose instruction. It can be used to release the device from the power-down state, obtain the devices electronic identification (ID) number or do both.

When used only to release the device from the power-down state, the instruction is issued by driving the /CS pin low, shifting the instruction code "ABh" and driving /CS high as shown in figure 14. After the time duration of t_{RES1} (See AC Characteristics) the device will resume normal operation and other instructions will be accepted. The /CS pin must remain high during the t_{RES1} time duration.

When used only to obtain the Device ID while not in the power-down state, the instruction is initiated by driving the /CS pin low and shifting the instruction code "ABh" followed by 3-dummy bytes. The Device ID bits are then shifted out on the falling edge of CLK with most significant bit (MSB) first as shown in figure 15. The Device ID values for the W25P10, W25P20, and W25P40 are listed in the Manufacturer and Device Identification table. The Device ID can be read continuously. The instruction is completed by driving /CS high.

When used to release the device from the power-down state and obtain the Device ID, the instruction is the same as previously described, and shown in figure 13, except that after /CS is driven high it must remain high for a time duration of t_{RES2} (See AC Characteristics). After this time duration the device will resume normal operation and other instructions will be accepted.

If the Release from Power-down / Device ID instruction is issued while an Erase, Program or Write cycle is in process (when BUSY equals 1) the instruction is ignored and will not have any effects on the current cycle.

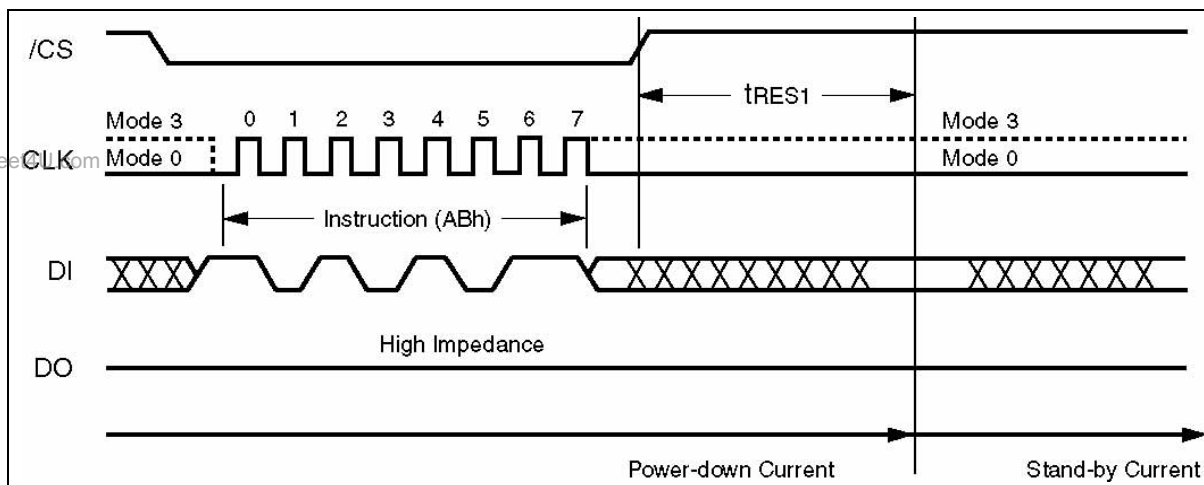

Figure 14. Release Power-down Instruction Sequence

W25P10, W25P20 AND W25P40

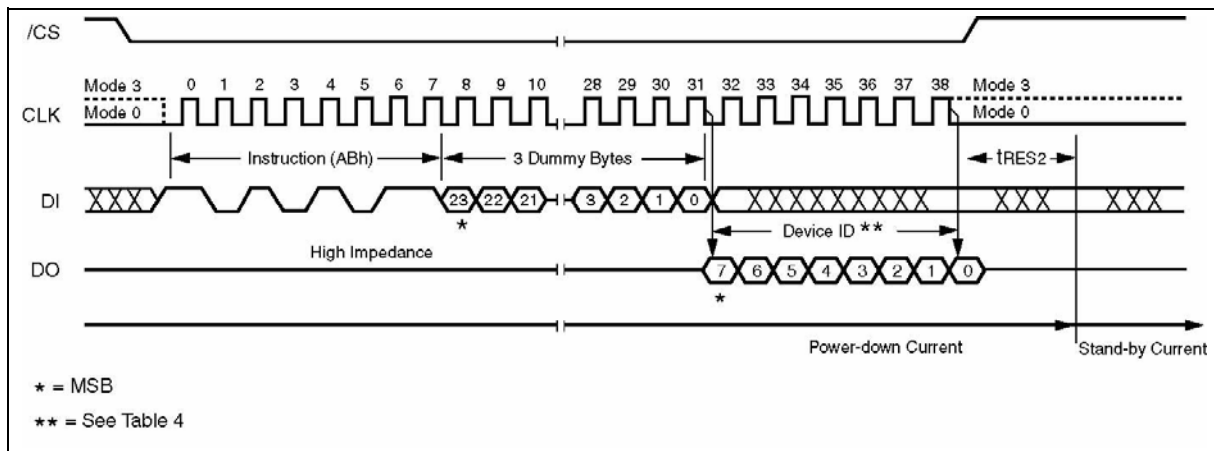

Figure 15. Release Power-down / Device ID Instruction Sequence Diagram

W25P10, W25P20 AND W25P40



7.2.14 Read Manufacturer / Device ID (90h)

The Read Manufacturer/Device ID instruction is an alternative to the Release from Power-down / Device ID instruction that provides both the JEDEC assigned manufacturer ID and the specific device ID.

The Read Manufacturer/Device ID instruction is very similar to the Release from Power-down / Device ID instruction. The instruction is initiated by driving the /CS pin low and shifting the instruction code "90h" followed by a 24-bit address (A23-A0) of 000000h. After which, the Manufacturer ID for Winbond (EFh) and the Device ID are shifted out on the falling edge of CLK with most significant bit (MSB) first as shown in figure 16. The Device ID values for the W25P10, W25P20, and W25P40 are listed in the Manufacturer and Device Identification table. If the 24-bit address is initially set to 000001h the Device ID will be read first and then followed by the Manufacturer ID. The Manufacturer and Device IDs can be read continuously, alternating from one to the other. The instruction is completed by driving /CS high.

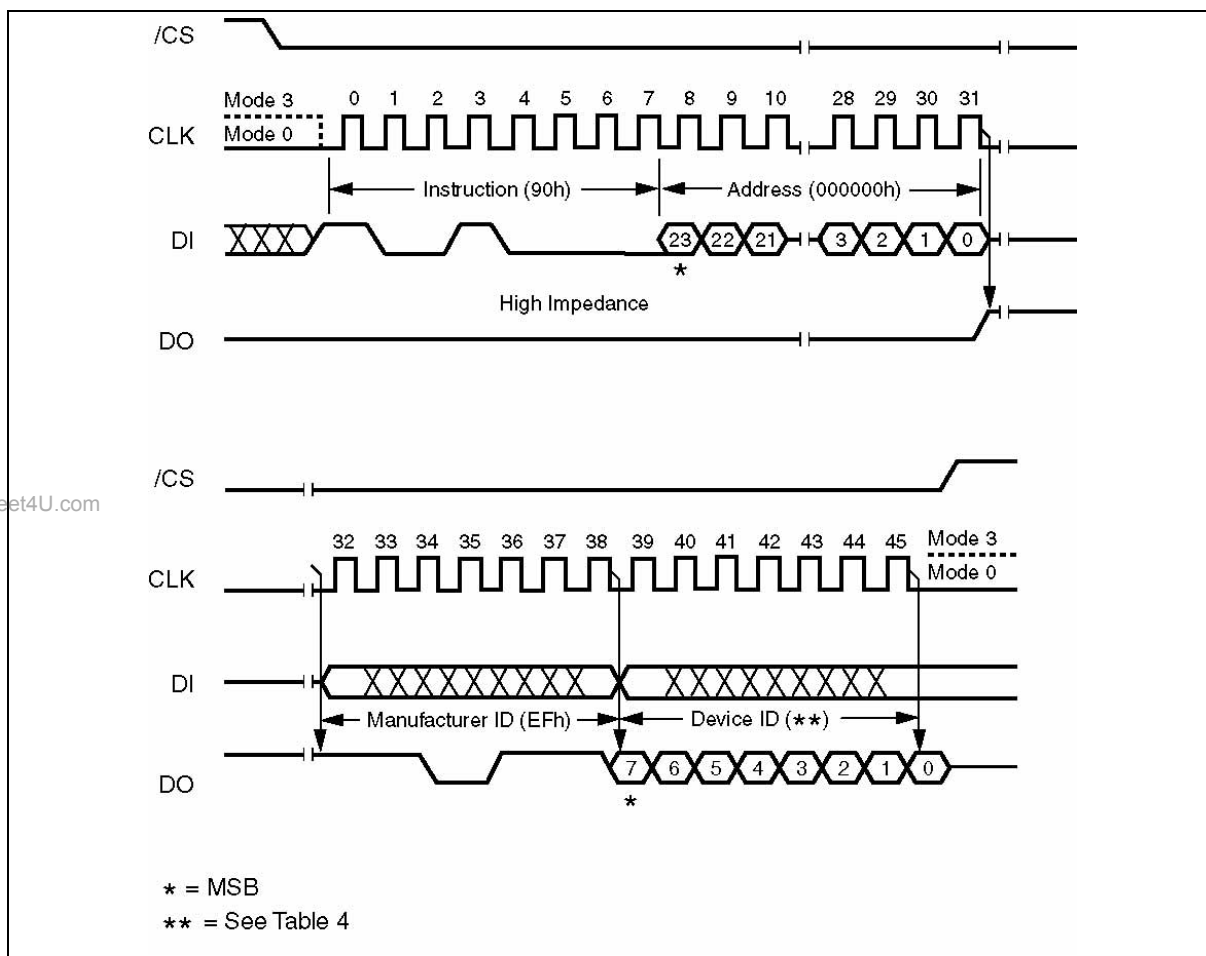

Figure 16. Read Manufacturer / Device ID Diagram

W25P10, W25P20 AND W25P40



8. ELECTRICAL CHARACTERISTICS

8.1 Absolute Maximum Ratings ⁽¹⁾

| PARAMETERS | SYMBOL | CONDITIONS | RANGE | UNIT |
|---------------------------------|--------|---------------------------------|------------------|------|
| Supply Voltage | VCC | | -0.6 to +4.0 | V |
| Voltage Applied to Any Pin | VIO | Relative to Ground | -0.6 to VCC +0.4 | V |
| Storage Temperature | TSTG | | -65 to +150 | °C |
| Lead Temperature | TLEAD | | See Note 2 | °C |
| Electrostatic Discharge Voltage | VESD | Human Body Model ⁽³⁾ | -2000 to +2000 | V |

Notes:

- 1 This device has been designed and tested for the specified operation ranges. Proper operation outside of these levels is not guaranteed. Exposure beyond absolute maximum ratings (listed above) may cause permanent damage.
2. Compliant with JEDEC Standard J-STD-20C for small body Sn-Pb or Pb-free (Green) assembly and the European directive on restrictions on hazardous substances (RoHS) 2002/95/EU..
3. JEDEC Std JESD22-A114A (C1=100 pF, R1=1500 ohms, R2=500 ohms).

8.2 Operating Ranges

| PARAMETER | SYMBOL | CONDITIONS | SPEC | | UNIT |
|--------------------------------|--------|------------------------|------|-----|------|
| | | | MIN | MAX | |
| Supply Voltage ⁽¹⁾ | VCC | FR = 33MHz, fR = 25MHz | 2.7 | 3.6 | V |
| | | FR = 40MHz, fR = 25MHz | 3.0 | 3.6 | V |
| Ambient Temperature, Operating | TA | Industrial | -40 | +85 | °C |

Note:

1. VCC voltage during Read can operate across the min and max range but should not exceed $\pm 10\%$ of the programming (erase/write) voltage.

W25P10, W25P20 AND W25P40



8.3 Power-up Timing and Write Inhibit Threshold

| PARAMETER | SYMBOL | SPEC | | UNIT |
|-------------------------------------|---------------------|------|-----|------|
| | | MIN | MAX | |
| VCC (min) to /CS Low | tvSL ⁽¹⁾ | 10 | | μs |
| Time Delay Before Write Instruction | tPUW ⁽¹⁾ | 1 | 10 | ms |
| Write Inhibit Threshold Voltage | VWI ⁽¹⁾ | 1 | 2 | V |

Note:

1. These parameters are characterized only.

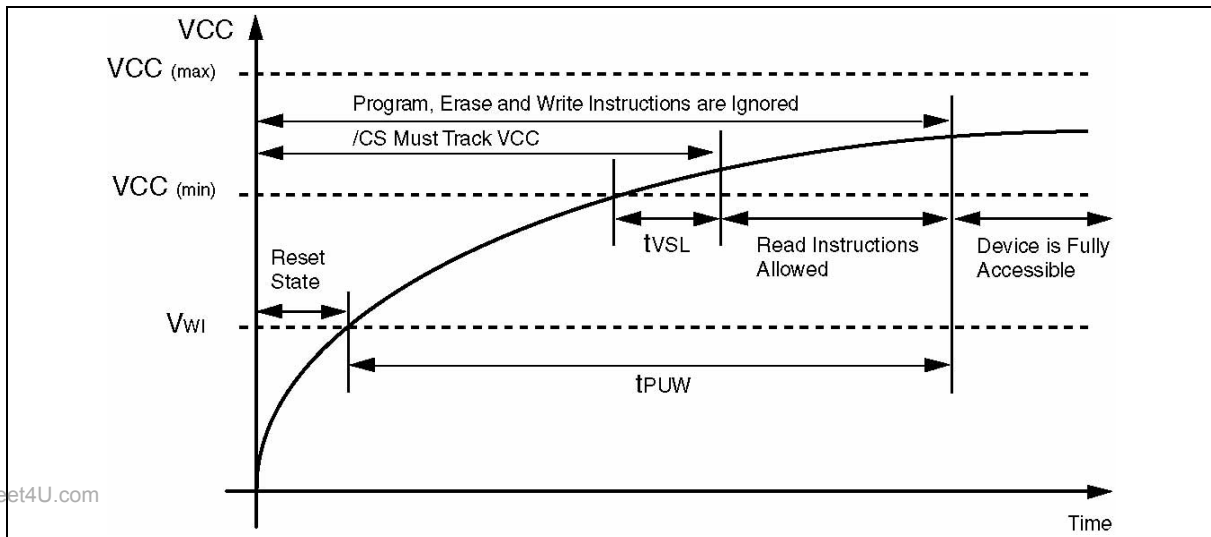

Figure 17. Power-up Timing and Voltage Levels

W25P10, W25P20 AND W25P40



8.4 DC Electrical Characteristics (Preliminary)⁽¹⁾

| PARAMETER | SYMBOL | CONDITIONS | SPEC | | | UNIT |
|----------------------------------|---------------------------------|--|----------|-----|----------|------|
| | | | MIN | TYP | MAX | |
| Input Capacitance | C _{IN} ⁽²⁾ | V _{IN} = 0V ⁽²⁾ | | | 6 | pf |
| Output Capacitance | C _{OUT} ⁽²⁾ | V _{OUT} = 0V ⁽²⁾ | | | 8 | pf |
| Input Leakage | I _{LI} | | | | ±2 | μA |
| I/O Leakage | I _{LO} | | | | ±2 | μA |
| Standby Current | I _{CC1} | /CS = VCC, V _{IN} = GND or VCC | | 25 | 50 | μA |
| Power-down Current | I _{CC2} | /CS = VCC, V _{IN} = GND or VCC | | <1 | 5 | μA |
| Current Read Data 1MHz | I _{CC3} | C = 0.1 VCC / 0.9 VCC DO = Open | | 4 | 7 | mA |
| Current Read Data 20MHz | | C = 0.1 VCC / 0.9 VCC DO = Open | | 10 | 14 | mA |
| Current Read Data 33MHz | | C = 0.1 VCC / 0.9 VCC DO = Open | | 14 | 18 | mA |
| Current Page Program | I _{CC4} | /CS = VCC | | 15 | 20 | mA |
| Current Write Status Register | I _{CC5} | /CS = VCC | | 8 | 20 | mA |
| Current Sector Erase | I _{CC6} | /CS = VCC | | 15 | 25 | mA |
| Current Chip Erase | I _{CC7} | /CS = VCC | | 17 | 25 | mA |
| Input Low Voltage | V _{IL} | | -0.5 | | VCC x0.3 | V |
| Input High Voltage | V _{IH} | | VCC x0.7 | | VCC +0.4 | V |
| Output Low Voltage | V _{OL} | I _{OL} = 1.6 mA | | | 0.4 | V |
| Output High Voltage | V _{OH} | I _{OH} = -100 μA | VCC -0.2 | | | V |

Notes:

1. See Preliminary Designation.
2. Tested on sample basis and specified through design and characterization data. TA=25° C, VCC 3V.

W25P10, W25P20 AND W25P40



8.5 AC Measurement Conditions

| PARAMETER | SYMBOL | SPEC | | UNIT |
|----------------------------------|--------|------------|---------|------|
| | | MIN | MAX | |
| Load Capacitance | CL | 30 | 30 | pF |
| Input Rise and Fall Times | TR, TF | | 5 | ns |
| Input Pulse Voltages | VIN | 0.2 VCC to | 0.8 VCC | V |
| Output Timing Reference Voltages | OUT | 0.3 VCC to | 0.7 VCC | V |

Note:

1. Output Hi-Z is defined as the point where data out is no longer driven.

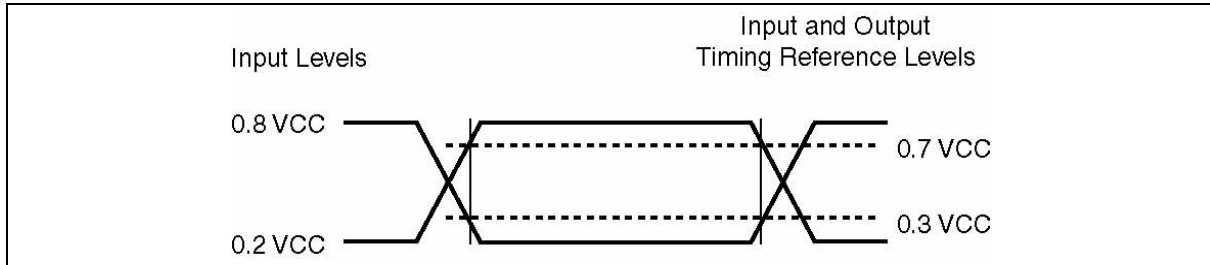

Figure 18. AC Measurement I/O Waveform

W25P10, W25P20 AND W25P40



8.6 AC Electrical Characteristics

| DESCRIPTION | SYMBOL | ALT | SPEC | | | UNIT |
|--|--------------------------------|------|--------------|-----|----------|------------|
| | | | MIN | TYP | MAX | |
| Clock frequency, for Fast Read (0Bh) and all other instructions except Read Data (03h) 2.7V-3.6V VCC 3.0V-3.6V VCC | FR | fc | D.C. D.C. | | 33 40 | MHz MHz |
| Clock freq. Read Data instruction (03h) | fR | | D.C. | | 25 | MHz |
| Clock High, Low Time, for Fast Read (0Bh) and all other instructions except Read Data (03h) | tCLH, tCLL ⁽¹⁾ | | 11 | | | ns |
| Clock High, Low Time for Read Data instruction | tCRLH, tCRLL ⁽¹⁾ | | 11 | | | ns |
| Clock Rise Time peak to peak | tCLCH ⁽²⁾ | | 0.1 | | | V/ns |
| Clock Fall Time peak to peak | tCHCL ⁽²⁾ | | 0.1 | | | V/ns |
| /CS Active Setup Time relative to CLK | tSLCH | tcSS | 5 | | | ns |
| /CS Not Active Hold Time relative to CLK | tCHSL | | 5 | | | ns |
| Data In Setup Time | tDVCH | tDSU | 2 | | | ns |
| Data In Hold Time | tCHDX | tDH | 5 | | | ns |
| /CS Active Hold Time relative to CLK (2.7V-3.6V / 3.0V-3.6V) | tCHSH | | 7/5 | | | ns |
| /CS Not Active Setup Time relative to CLK | tSHCH | | 5 | | | ns |
| /CS Deselect Time | tSHSL | tCSH | 100 | | | ns |
| Output Disable Time | tSHQZ ⁽²⁾ | tDIS | | | 9 | ns |
| Clock Low to Output Valid (2.7V-3.6V / 3.0V-3.6V) | tCLQV | tv | | | 13/9 | ns |
| Output Hold Time | tCLQX | tHO | 0 | | | ns |
| /HOLD Active Setup Time relative to CLK (2.7V-3.6V / 3.0V-3.6V) | tHLCH | | 6/5 | | | ns |

Continued – next page

W25P10, W25P20 AND W25P40



8.7 AC Electrical Characteristics (cont'd)

| DESCRIPTION | SYMBOL | ALT | SPEC | | | UNIT |
|--|----------------------|-----|------|-----|-----|------|
| | | | MIN | TYP | MAX | |
| /HOLD Active Hold Time relative to CLK | tCHHH | | 5 | | | ns |
| /HOLD Not Active Setup Time relative to CLK | tHHCH | | 5 | | | ns |
| /HOLD Not Active Hold Time relative to CLK | tCHHL | | 5 | | | ns |
| /HOLD to Output Low-Z | tHHQX ⁽²⁾ | tLZ | | | 9 | ns |
| /HOLD to Output High-Z | tHLQZ ⁽²⁾ | tHZ | | | 9 | ns |
| Write Protect Setup Time Before /CS Low | tWHSL ⁽⁴⁾ | | 20 | | | ns |
| Write Protect Hold Time After /CS High | tSHWL ⁽⁴⁾ | | 100 | | | ns |
| /CS High to Power-down Mode | tDP ⁽²⁾ | | | | 3 | μs |
| /CS High to Standby Mode without Electronic Signature Read | tRES1 ⁽²⁾ | | | | 3 | μs |
| /CS High to Standby Mode with Electronic Signature Read | tRES2 ⁽²⁾ | | | | 1.8 | μs |
| Write Status Register Cycle Time | tW | | | 10 | 15 | ms |
| Page Program Cycle Time | tPP | | | 2 | 5 | ms |
| Sector Erase Cycle Time | tSE | | | 0.7 | 3 | s |
| Chip Erase Cycle Time W25P10 and W25P20 | tCE | | | 3 | 6 | s |
| Chip Erase Cycle Time W25P40 | | | | 5 | 10 | s |

Notes:

1. Clock high + Clock low must be less than or equal to 1/fc.
2. Value guaranteed by design and/or characterization, not 100% tested in production.
3. Expressed as a slew-rate.
4. Only applicable as a constraint for a Write Status Register instruction when Sector Protect Bit is set at 1.

W25P10, W25P20 AND W25P40



8.8 Serial Output Timing

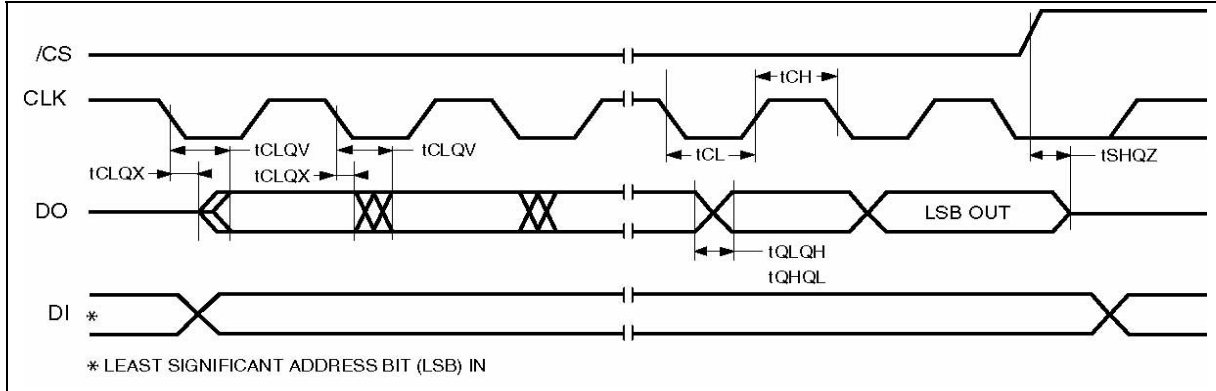

8.9 Input Timing

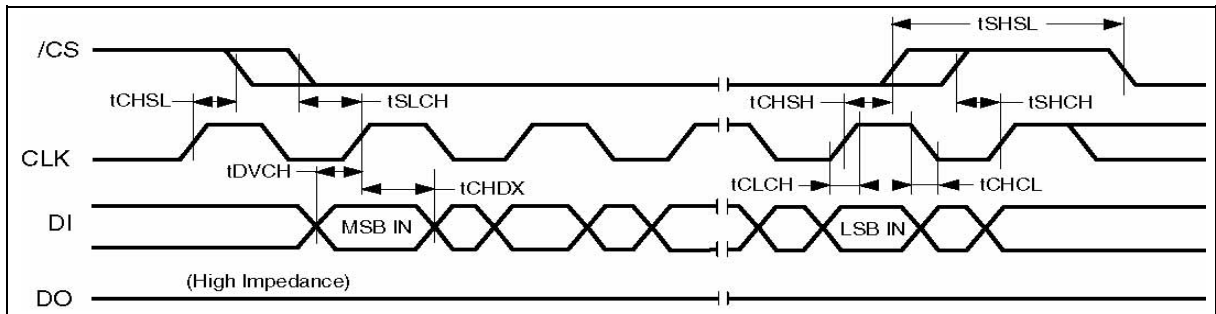

8.10 Hold Timing

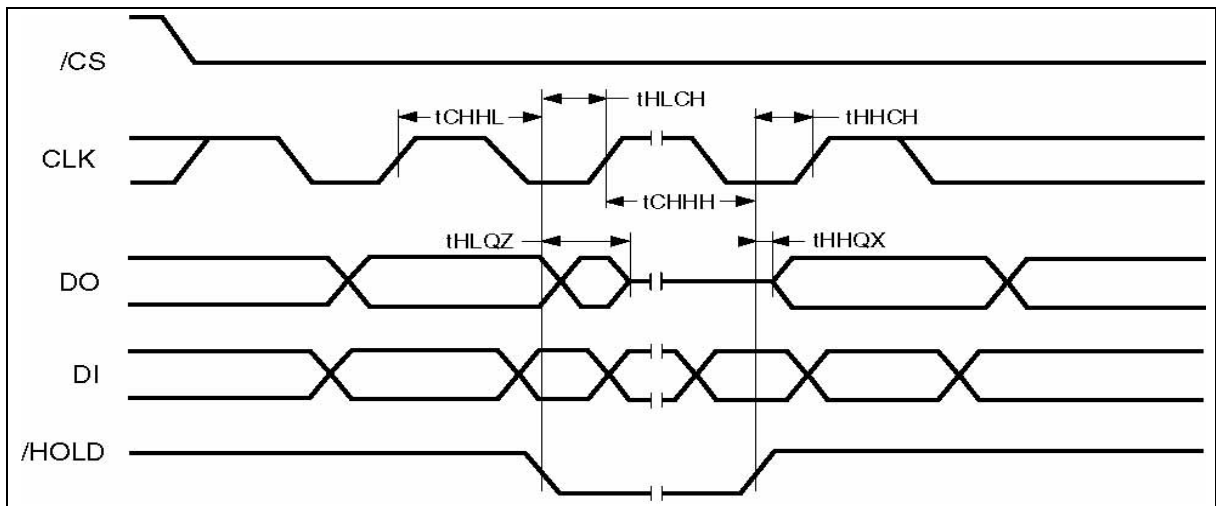

W25P10, W25P20 AND W25P40



9. PACKAGE SPECIFICATION

9.1 8-Pin SOIC 150-mil (Winbond Package Code SN)

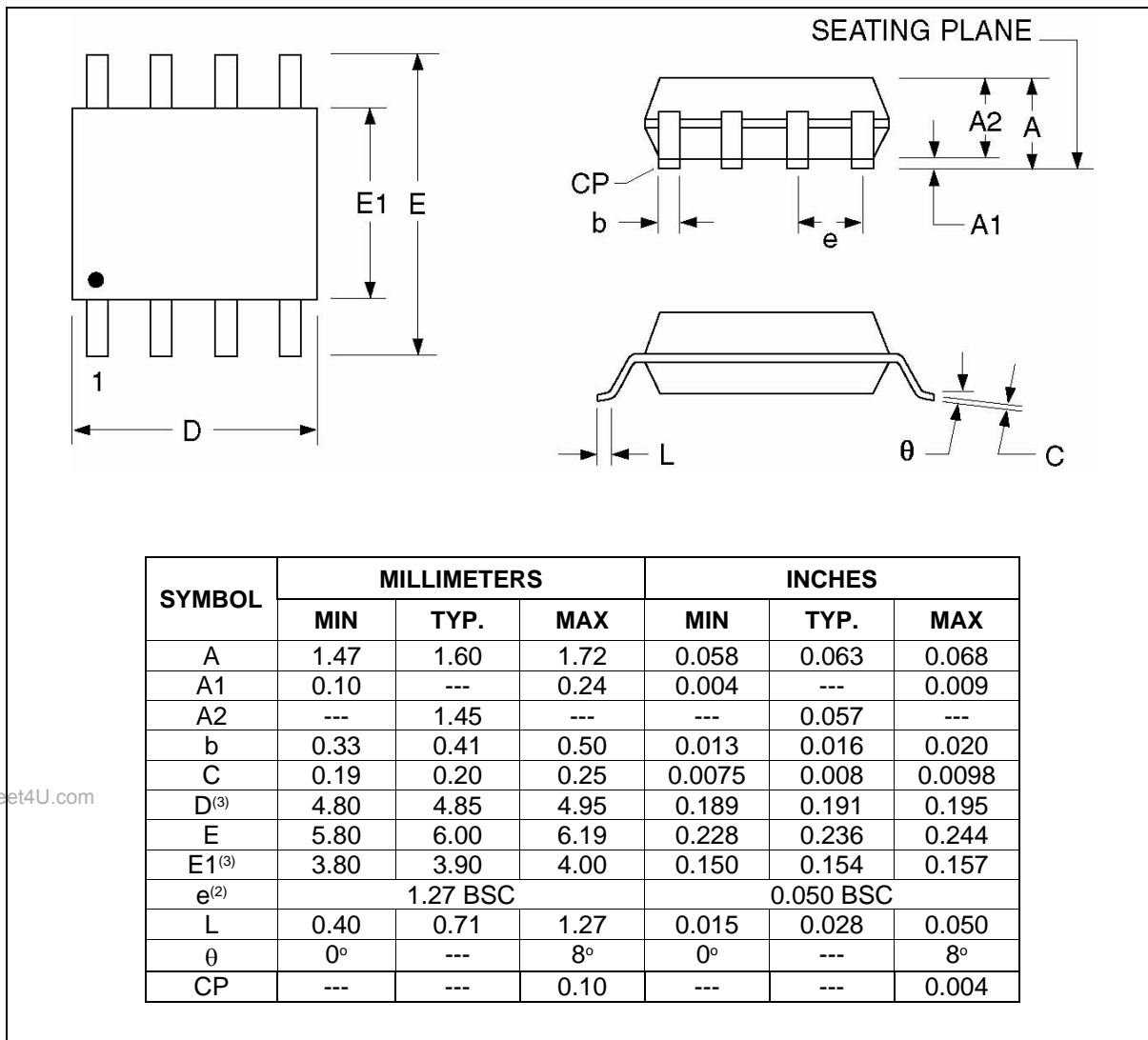
**Notes:**

1. Controlling dimensions: inches, unless otherwise specified.
2. BSC = Basic lead spacing between centers.
3. Dimensions D and E1 do not include mold flash protrusions and should be measured from the bottom of the package.
4. Formed leads shall be planar with respect to one another within .0004 inches at the seating plane.

W25P10, W25P20 AND W25P40



10. ORDERING INFORMATION

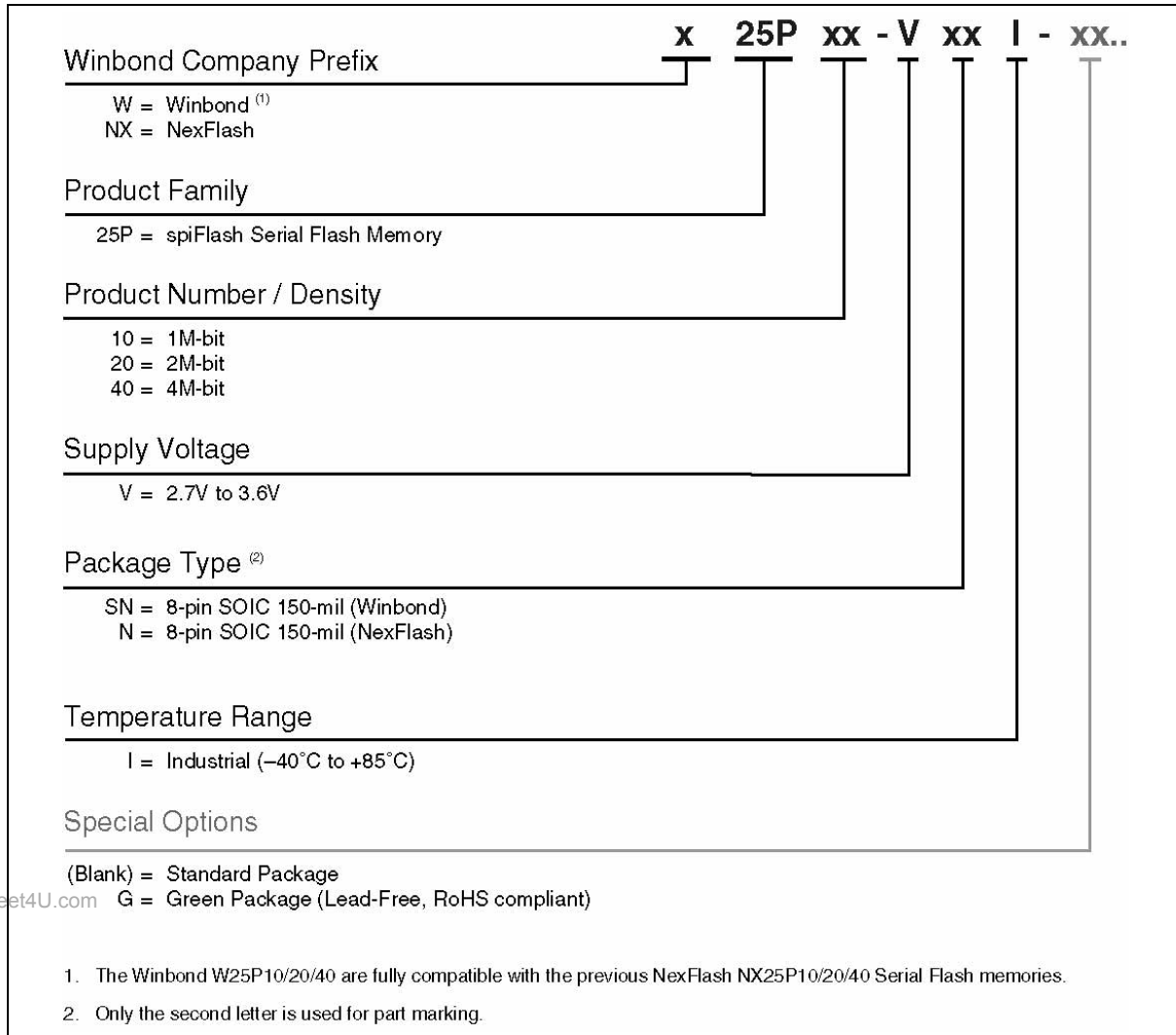

W25P10, W25P20 AND W25P40**11. REVISION HISTORY**

| VERSION | DATE | PAGE | DESCRIPTION |
|---------|----------|--------------------|--|
| A | 04/29/03 | | New Create |
| B | 09/12/03 | | Incorporated spiFlash trademark for W25P10, 20 and 40 product family. Adjusted data for consistency |
| C | 03/09/04 | 10, 11, 14, 16, 24 | Adjusted pages for technical clarity. Updated Special Options and Ordering Information |
| D | 03/24/04 | | MLP metal die pad notification; Under "Package Types," figure 3 and packaging information. |
| E | 05/11/04 | | Corrected dimensions in Packaging Information section for 6x5mm MLP. Updated Characterization information DC & AC |
| F | 06/16/04 | | Modified dimensional data in the Packaging Information for the 6x5mm MLP package |
| G | 11/23/04 | | Added FR = 40MHz @ 3.0V to 3.6V VCC. Added fR = 33MHz @ 3.0V to 3.6V VCC. Modified tLEAD in Absolute Maximum Ratings to reference JEDEC Standard information. Added FR and fR conditions to Operating Ranges. Updated Icc3 and Icc5 data in DC Electrical Characteristics. Added 20/33MHz call outs and updated min, max and typ data in AC Electrical Characteristics |
| H | 12/08/04 | | Updated 8-pin 150-mil SOIC package information. |
| I | 04/04/05 | | Removed 8-contact 6x5 MLP package from document. |
| J | 05/09/05 | | Updated and improved AC Parameters in Table 7.6 and changed tCHSH, tCLQV and tHLCH to reference voltage (2.7V-3.6V / 3.0V-3.6V) for consistency with other spiFlash memory data sheets. |
| K | 06/14/05 | | Updated Important Notice. |
| L | 06/28/05 | | Changed NexFlash part numbers to Winbond part numbers and updated ordering and contact information |
| M | 11/28/05 | ALL | Updated data sheet to comply with Winbond standard Updated FR and fR values in Operating Ranges Table and AC Characteristics Table. Updated Read Data (fR) values in Operating Range and AC Characteristics Tables from 33MHz to 25MHz. Corrected the pin assignment on table of pin description of page 5. |

W25P10, W25P20 AND W25P40



Preliminary Designation

The "Preliminary" designation on a *Winbond* data sheet indicates that the product is not fully characterized. The specifications are subject to change and are not guaranteed. *Winbond* or an authorized sales representative should be consulted for current information before using this product.

Trademarks

Winbond and *spiFlash* are trademarks of *Winbond Electronics Corporation*. All other marks are the property of their respective owner.

Important Notice

Winbond products are not designed, intended, authorized or warranted for use as components in systems or equipment intended for surgical implantation, atomic energy control instruments, airplane or spaceship instruments, transportation instruments, traffic signal instruments, combustion control instruments, or for other applications intended to support or sustain life. Further more, Winbond products are not intended for applications wherein failure of Winbond products could result or lead to a situation wherein personal injury, death or severe property or environmental damage could occur.

Winbond customers using or selling these products for use in such applications do so at their own risk and agree to fully indemnify Winbond for any damages resulting from such improper use or sales.



The Winbond W25P10/20/40 are fully compatible with the previous NexFlash NX25P10/20/40 Serial Flash memories.

Please note that all data and specifications are subject to change without notice.
All the trademarks of products and companies mentioned in this datasheet belong to their respective owners.

Publication Release Date: November 28, 2005