

SERVICE MANUAL

W270HSQ

notebook



Notebook Computer

W270HSQ

Service Manual

Notice

The company reserves the right to revise this publication or to change its contents without notice. Information contained herein is for reference only and does not constitute a commitment on the part of the manufacturer or any subsequent vendor. They assume no responsibility or liability for any errors or inaccuracies that may appear in this publication nor are they in anyway responsible for any loss or damage resulting from the use (or misuse) of this publication.

This publication and any accompanying software may not, in whole or in part, be reproduced, translated, transmitted or reduced to any machine readable form without prior consent from the vendor, manufacturer or creators of this publication, except for copies kept by the user for backup purposes.

Brand and product names mentioned in this publication may or may not be copyrights and/or registered trademarks of their respective companies. They are mentioned for identification purposes only and are not intended as an endorsement of that product or its manufacturer.

Version 1.0
March 2012

Trademarks

Intel, Pentium and Intel Core are trademarks of Intel Corporation.

Windows[®] is a registered trademark of Microsoft Corporation.

Other brand and product names are trademarks and /or registered trademarks of their respective companies.

About this Manual

This manual is intended for service personnel who have completed sufficient training to undertake the maintenance and inspection of personal computers.

It is organized to allow you to look up basic information for servicing and/or upgrading components of the *W270HSQ* series notebook PC.

The following information is included:

Chapter 1, Introduction, provides general information about the location of system elements and their specifications.

Chapter 2, Disassembly, provides step-by-step instructions for disassembling parts and subsystems and how to upgrade elements of the system.

Appendix A, Part Lists

Appendix B, Schematic Diagrams

Appendix C, Updating the FLASH ROM BIOS

IMPORTANT SAFETY INSTRUCTIONS

Follow basic safety precautions, including those listed below, to reduce the risk of fire, electric shock and injury to persons when using any electrical equipment:

1. Do not use this product near water, for example near a bath tub, wash bowl, kitchen sink or laundry tub, in a wet basement or near a swimming pool.
2. Avoid using a telephone (other than a cordless type) during an electrical storm. There may be a remote risk of electrical shock from lightning.
3. Do not use the telephone to report a gas leak in the vicinity of the leak.
4. Use only the power cord and batteries indicated in this manual. Do not dispose of batteries in a fire. They may explode. Check with local codes for possible special disposal instructions.
5. This product is intended to be supplied by a Listed Power Unit with an AC Input of 100 - 240V, 50 - 60Hz, DC Output of 19V, 474A (90W) minimum AC/DC Adapter.

CAUTION

This Computer's Optical Device is a Laser Class 1 Product

FCC Statement

This device complies with Part 15 of the FCC Rules. Operation is subject to the following two conditions:

This device may not cause harmful interference.

This device must accept any interference received, including interference that may cause undesired operation.

Instructions for Care and Operation

The notebook computer is quite rugged, but it can be damaged. To prevent this, follow these suggestions:

1. **Don't drop it, or expose it to shock.** If the computer falls, the case and the components could be damaged.

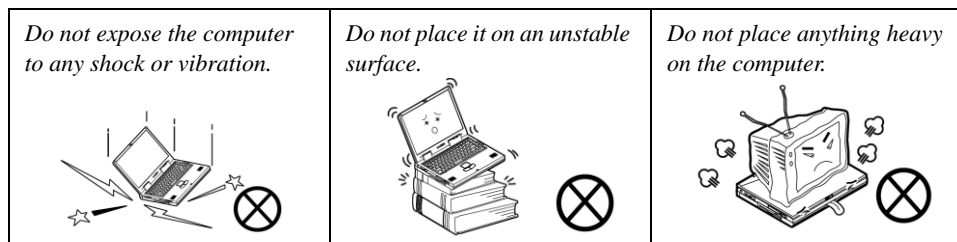

2. **Keep it dry, and don't overheat it.** Keep the computer and power supply away from any kind of heating element. This is an electrical appliance. If water or any other liquid gets into it, the computer could be badly damaged.

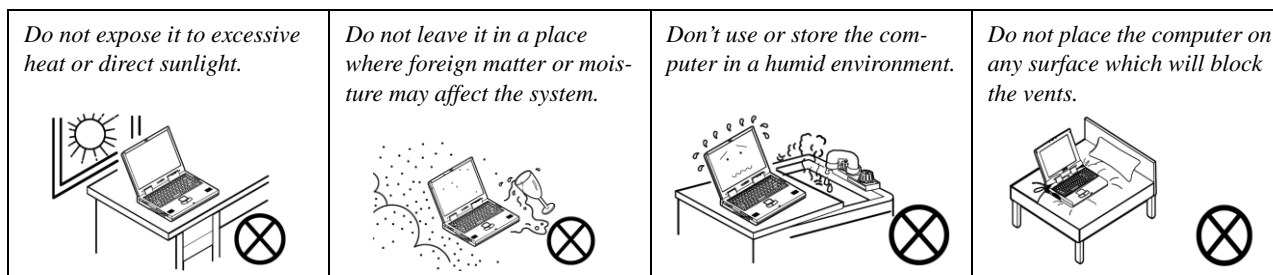

3. **Follow the proper working procedures for the computer.** Shut the computer down properly and don't forget to save your work. Remember to periodically save your data as data may be lost if the battery is depleted.

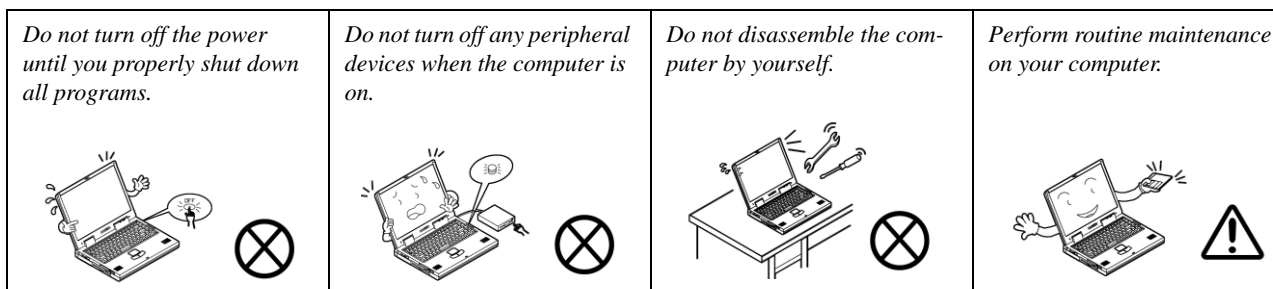

4. **Avoid interference.** Keep the computer away from high capacity transformers, electric motors, and other strong magnetic fields. These can hinder proper performance and damage your data.
5. **Take care when using peripheral devices.**

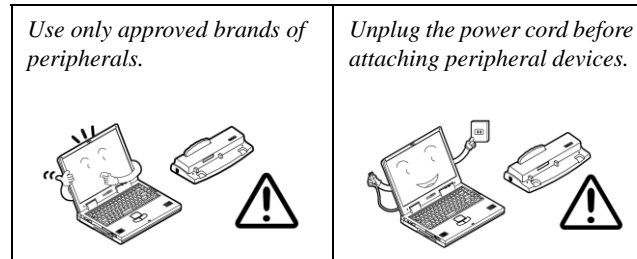

Power Safety

The computer has specific power requirements:

- Only use a power adapter approved for use with this computer.
- Your AC adapter may be designed for international travel but it still requires a steady, uninterrupted power supply. If you are unsure of your local power specifications, consult your service representative or local power company.
- The power adapter may have either a 2-prong or a 3-prong grounded plug. The third prong is an important safety feature; do not defeat its purpose. If you do not have access to a compatible outlet, have a qualified electrician install one.
- When you want to unplug the power cord, be sure to disconnect it by the plug head, not by its wire.
- Make sure the socket and any extension cord(s) you use can support the total current load of all the connected devices.
- Before cleaning the computer, make sure it is disconnected from any external power supplies.

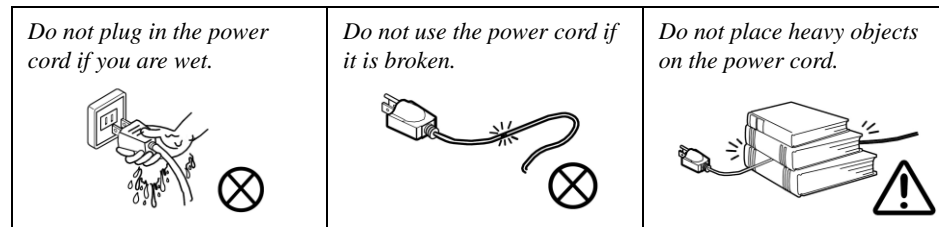

Power Safety Warning

Before you undertake any upgrade procedures, make sure that you have turned off the power, and disconnected all peripherals and cables (including telephone lines). It is advisable to also remove your battery in order to prevent accidentally turning the machine on.

Battery Precautions

- Only use batteries designed for this computer. The wrong battery type may explode, leak or damage the computer.
- Do not continue to use a battery that has been dropped, or that appears damaged (e.g. bent or twisted) in any way. Even if the computer continues to work with a damaged battery in place, it may cause circuit damage, which may possibly result in fire.
- Recharge the batteries using the notebook's system. Incorrect recharging may make the battery explode.
- Do not try to repair a battery pack. Refer any battery pack repair or replacement to your service representative or qualified service personnel.
- Keep children away from, and promptly dispose of a damaged battery. Always dispose of batteries carefully. Batteries may explode or leak if exposed to fire, or improperly handled or discarded.
- Keep the battery away from metal appliances.
- Affix tape to the battery contacts before disposing of the battery.
- Do not touch the battery contacts with your hands or metal objects.

Battery Guidelines

The following can also apply to any backup batteries you may have.

- If you do not use the battery for an extended period, then remove the battery from the computer for storage.
- Before removing the battery for storage charge it to 60% - 70%.
- Check stored batteries at least every 3 months and charge them to 60% - 70%.



Battery Disposal

The product that you have purchased contains a rechargeable battery. The battery is recyclable. At the end of its useful life, under various state and local laws, it may be illegal to dispose of this battery into the municipal waste stream. Check with your local solid waste officials for details in your area for recycling options or proper disposal.

Caution

Danger of explosion if battery is incorrectly replaced. Replace only with the same or equivalent type recommended by the manufacturer. Discard used battery according to the manufacturer's instructions.

Battery Level

Click the battery icon  in the taskbar to see the current battery level and charge status. A battery that drops below a level of 10% will not allow the computer to boot up. Make sure that any battery that drops below 10% is recharged within one week.

Related Documents

You may also need to consult the following manual for additional information:

User's Manual on CD/DVD

This describes the notebook PC's features and the procedures for operating the computer and its ROM-based setup program. It also describes the installation and operation of the utility programs provided with the notebook PC.

System Startup

1. Remove all packing materials.
2. Place the computer on a stable surface.
3. Insert the battery and make sure it is locked in position.
4. Securely attach any peripherals you want to use with the computer (e.g. keyboard and mouse) to their ports.
5. Attach the AC/DC adapter to the DC-In jack at the rear of the computer, then plug the AC power cord into an outlet, and connect the AC power cord to the AC/DC adapter.
6. Use one hand to raise the lid/LCD to a comfortable viewing angle (do not exceed 130 degrees); use the other hand (as illustrated in Figure 1) to support the base of the computer (**Note: Never** lift the computer by the lid/LCD).
7. Press the power button to turn the computer "on".



Figure 1
**Opening the Lid/LCD/
Computer with AC/DC
Adapter Plugged-In**

Shut Down

Note that you should always shut your computer down by choosing **Shut Down** from the **Start** Menu.

This will help prevent hard disk or system problems.

Contents

Introduction	1-1	DVD DUAL	A-6
Overview	1-1	LCD	A-7
Specifications	1-2	Schematic Diagrams.....	B-1
External Locator - Top View with LCD Panel Open	1-5	System Block Diagram	B-2
External Locator - Front & Right Side Views	1-6	Processor 1/7-DMI, FDI, PEG	B-3
External Locator - Left Side & Rear View	1-7	Processor 2/7- CLK, MISC	B-4
External Locator - Bottom View	1-8	Processor 3/7- (DDR3)	B-5
Mainboard Overview - Top (Key Parts)	1-9	Processor 4/7- Power	B-6
Mainboard Overview - Bottom (Key Parts)	1-10	Processor 5/7- GFX PWR	B-7
Mainboard Overview - Top (Connectors)	1-11	Processor 6/7- GND	B-8
Mainboard Overview - Bottom (Connectors)	1-12	Processor 7/7- RSVD	B-9
Disassembly	2-1	DDR3 SO-DIMM_0	B-10
Overview	2-1	DDR3 SO-DIMM_1	B-11
Maintenance Tools	2-2	PANEL, INVERTER, CRT	B-12
Connections	2-2	VGA PCI-E Interface	B-13
Maintenance Precautions	2-3	VGA Frame Buffer Interface	B-14
Disassembly Steps	2-4	VGA Frame Buffer A	B-15
Removing the Battery	2-5	VGA Frame Buffer C	B-16
Removing the Hard Disk Drive	2-6	VGA I/O	B-17
Removing the Optical (CD/DVD) Device	2-8	VGA NVVDD Cecoupling	B-18
Removing the System Memory (RAM)	2-9	PCH 1/9- RTC, HDA, SATA	B-19
Removing and Installing a Processor	2-11	PCH 2/9- PCIE, SMBUS, CLK	B-20
Removing the Wireless LAN Module	2-14	PCH 3/9- DMI, FDI, PWRGD	B-21
Removing the Keyboard	2-15	PCH 4/9- LVDS, DDI, CRT	B-22
Part Lists	A-1	PCH 4/9- PCI, USB, RSVD	B-23
Part List Illustration Location	A-2	PCH 6/9- GPIO, CPU	B-24
Top	A-3	PCH 7/9- PWR	B-25
Bottom	A-4	PCH 8/9 POWER	B-26
SATA BLU RAY COMBO	A-5	PCH 9/9- GND	B-27
		WLAN, 3G, MINI PCIE	B-28

Preface

CCD, TPM, MULTI CON	B-29
USB3.0	B-30
Card Reader (RTL8411)	B-31
SATA ODD, LED, USB CHARGE	B-32
HDMI, RJ45	B-33
AUDIO CODEC VT1802P	B-34
KBC-ITE IT8518E	B-35
5VS, 3VS, 1.5VS CPU	B-36
VDD3, VDD5	B-37
Power 0.85VS, 1.8VS	B-38
POWER 1.5V/1.05VS	B-39
POWER 1.05V/1.05VS VTT	B-40
POWER VCORE1	B-41
POWER VCORE2	B-42
Power VGA NVVDD/PEX_VDD	B-43
AC IN, CHARGER	B-44
AUDIO BOARD	B-45
CLICK BOARD	B-46
W251HPQ POWER SW BOARD	B-47
W270HU BRIDGE ODD BOARD	B-48
W270HU POWER SW BOARD	B-49
Power Diagram	B-50
Power On SEQ	B-51
Updating the FLASH ROM BIOS.....	C-1

Chapter 1: Introduction

Overview

This manual covers the information you need to service or upgrade the **W270HSQ** series notebook computer. Information about operating the computer (e.g. getting started, and the *Setup* utility) is in the *User's Manual*. Information about drivers (e.g. VGA & audio) is also found in the *User's Manual*. The manual is shipped with the computer.

Operating systems (e.g. *Window 7*, etc.) have their own manuals as do application softwares (e.g. word processing and database programs). If you have questions about those programs, you should consult those manuals.

The **W270HSQ** series notebook is designed to be upgradeable. See *Disassembly on page 2 - 1* for a detailed description of the upgrade procedures for each specific component. Please take note of the warning and safety information indicated by the “” symbol.

The balance of this chapter reviews the computer's technical specifications and features.

Specifications



Latest Specification Information

The specifications listed here are correct at the time of sending them to the press. Certain items (particularly processor types/speeds) may be changed, delayed or updated due to the manufacturer's release schedule. Check with your service center for more details.



CPU

The CPU is not a user serviceable part. Accessing the CPU in any way may violate your warranty.

Processor
<i>Note all processor packages are rPGA988B</i>
Intel® Core i7-2860QM (2.5GHz) Quad-Core Mobile Processor 8M L3 Cache, 32nm (32 Nanometer), DDR3-1600MHz, TDP 45W
Intel® Core i7-2820QM (2.3GHz) Quad-Core Mobile Processor 8M L3 Cache, 32nm (32 Nanometer), DDR3-1600MHz, TDP 45W
Intel® Core i7-2760QM (2.4GHz) Quad-Core Mobile Processor 6M L3 Cache, 32nm (32 Nanometer), DDR3-1600MHz, TDP 45W
Intel® Core i7-2720QM (2.2GHz) Quad-Core Mobile Processor 6M L3 Cache, 32nm (32 Nanometer), DDR3-1600MHz, TDP 45W
Intel® Core i7-2670QM (2.2GHz) Quad-Core Mobile Processor 6M L3 Cache, 32nm (32 Nanometer), DDR3-1333MHz, TDP 45W
Intel® Core i7-2630QM (2.0GHz) Quad-Core Mobile Processor 6M L3 Cache, 32nm (32 Nanometer), DDR3-1333MHz, TDP 45W
Intel® Core i7-2640M (2.8GHz) Mobile Processor 4M L3 Cache, 32nm (32 Nanometer), DDR3-1333MHz, TDP 35W

Processor
Intel® Core i7-2620M (2.7GHz) Mobile Processor 4M L3 Cache, 32nm (32 Nanometer), DDR3-1333MHz, TDP 35W
Intel® Core i5-2540M (2.6GHz) Mobile Processor 3M L3 Cache, 32nm (32 Nanometer), DDR3-1333MHz, TDP 35W
Intel® Core i5-2520M (2.5GHz) Mobile Processor 3M L3 Cache, 32nm (32 Nanometer), DDR3-1333MHz, TDP 35W
Intel® Core i5-2430M (2.4GHz) Mobile Processor 3M L3 Cache, 32nm (32 Nanometer), DDR3-1333MHz, TDP 35W
Intel® Core i5-2410M (2.3GHz) Mobile Processor 3M L3 Cache, 32nm (32 Nanometer), DDR3-1333MHz, TDP 35W
Intel® Core i3-2350M (2.3GHz) Mobile Processor 3M L3 Cache, 32nm (32 Nanometer), DDR3-1333MHz, TDP 35W
Intel® Core i3-2330M (2.2GHz) Mobile Processor 3M L3 Cache, 32nm (32 Nanometer), DDR3-1333MHz, TDP 35W
Intel® Core i3-2310M (2.1GHz) Mobile Processor 3M L3 Cache, 32nm (32 Nanometer), DDR3-1333MHz, TDP 35W

Processor
Intel® Pentium® B960 (2.2GHz) 2M L3 Cache, 32nm (32 Nanometer), DDR3-1333MHz, TDP 35W
Intel® Pentium® B950 (2.1GHz) 2M L3 Cache, 32nm (32 Nanometer), DDR3-1333MHz, TDP 35W
Intel® Pentium® B940 (2.0GHz) 2M L3 Cache, 32nm (32 Nanometer), DDR3-1333MHz, TDP 35W
Core Logic
Mobile Intel® HM65 Express Chipset
Display
17.3" / 43.94cm HD+ (1600 * 900) / FHD (1920 * 1080) 16:9 Backlit Panel
Memory
Dual Channel DDRIII (DDR3) Two 204 Pin SO-DIMM sockets supporting DDR3 1333MHz/1600MHz (real operational frequency depends on the FSB of the processor) Memory Expandable up to 8GB (using 1GB / 2GB / 4GB SO-DIMM Modules)

Video Controller
Intel® Integrated GPU and NVIDIA® GeForce GT 630M Video: Supports NVIDIA® Optimus Switchable GPU Technology between iGPU and dGPU Intel® HD Graphics 3000: Dynamic Frequency DVM Shared Memory Architecture up to 1748MB Microsoft DirectX®10 Compatible NVIDIA® GeForce GT 630M Discrete GPU: 1GB DDR3 Video RAM Supports PCIe * 8 Microsoft DirectX®11 Compatible NVIDIA PhysX™ GeForce CUDA™ Technology NVIDIA® Optimus 1.2 Technology
BIOS
One 32Mb SPI Flash ROM AMI BIOS
Storage
One Changeable 12.7mm(h) Super Multi/Blu-ray Combo Optical Device Drive with SATA Interface (Factory Option) One Changeable 2.5" / 9.5 mm (h) HDD with SATA (Serial) Interface
Audio
High Definition Audio Interface Built-In Microphone 2 * Built-In Speakers THX TruStudio Pro

Keyboard, Pointing Device & Buttons
Isolated Keyboard with Numeric Keypad Built-in Touchpad with Multi-Gesture Functionality
Interface
One USB 2.0 Port Two USB 3.0 Ports One eSATA Port One External Monitor Port One HDMI1.4a Out Port (with HDCP) One Headphone-Out Jack One Microphone-In Jack One RJ-45 LAN Jack One DC-In Jack
Card Reader
Embedded Multi-In-1 Card Reader - MMC/ RS MMC - SD/ Mini SD / SDHC/ SDXC - MS/ MS Pro/ MS Duo Note: Some of these cards require PC adapters that are usually supplied with the cards.
Slots
For Half Size WLAN Combo Module with PCIe and USB Interface
Communication
Built-In 10/100/1000Mb Base-TX Ethernet LAN Intel® Centrino® Advanced-N 6230 (2*2 802.11 a/g/n) Half Mini-Card PCIe WLAN & Bluetooth 3.0 Combo Module (Factory Option) Intel® Centrino® Wireless-N 1030 (1*2 802.11 b/g/n) Half Mini-Card PCIe WLAN & Bluetooth 3.0 Combo Module (Factory Option)

Introduction

Communication
3rd Party Combo WLAN (802.11b/g/n) and Bluetooth v3.0+HS Half Mini-Card Module with PCIe Interface (Factory Option)
3rd Party WLAN 802.11b/g/n Half Mini-Card Module with PCIe Interface (Factory Option)
1.3M/2.0M Pixel PC Camera Module with USB interface (Factory Option)
Power Management
Supports Wake on LAN Supports Wake on USB Energy Star 5.2
Power
Full Range AC/DC Adapter AC input 100 - 240V, 50 - 60Hz, DC Output 19V, 4.7A (90 Watts) Removable 6 Cell Smart Lithium Ion Battery Pack 48.84WH Removable 6 Cell Smart Lithium Ion Battery Pack 62.16WH (Factory Option)
Security
Security (Kensington® Type) Lock Slot BIOS Password
Operating System
Windows® 7 with Service Pack 1
Design Feature
IMR (Injected Molded Resin) LCD Back Covers (For Some Model Designs)

Environmental Spec
Temperature Operating: 5°C - 35°C Non-Operating: -20°C - 60°C
Relative Humidity Operating: 20% - 80% Non-Operating: 10% - 90%
Dimensions & Weight
413mm (w) * 270mm (d) * 14 - 40.5mm(h) 3kg with ODD & 48.84WH Battery

External Locator - Top View with LCD Panel Open



Figure 1
Top View

1. PC Camera
(Optional)
2. LCD
3. Power Button
4. LED Status
Indicators
5. Keyboard
6. Built-In
Microphone
7. Touchpad &
Buttons

Introduction

Figure 2
Front View

1. LED Power Indicator

External Locator - Front & Right Side Views

FRONT VIEW



Figure 3
Right Side View

1. Microphone-In Jack
2. Headphone-Out Jack
3. USB 2.0 Port
4. Optical Device Drive Bay
5. Emergency Eject Hole
6. Security Lock Slot

RIGHT SIDE VIEW



External Locator - Left Side & Rear View

LEFT SIDE VIEW



Figure 4
Left Side View

1. DC-In Jack
2. External Monitor Port
3. RJ-45 LAN Jack
4. HDMI-Out Port
5. USB 3.0 Ports
6. Vent
7. Multi-in-1 Card Reader
8. e-SATA Port

REAR VIEW



Figure 5
Rear View

1. Battery

External Locator - Bottom View

Figure 6
Bottom View

1. Battery
2. Component Bay Cover
3. Vent
4. Hard Disk Bay Cover
5. Speakers

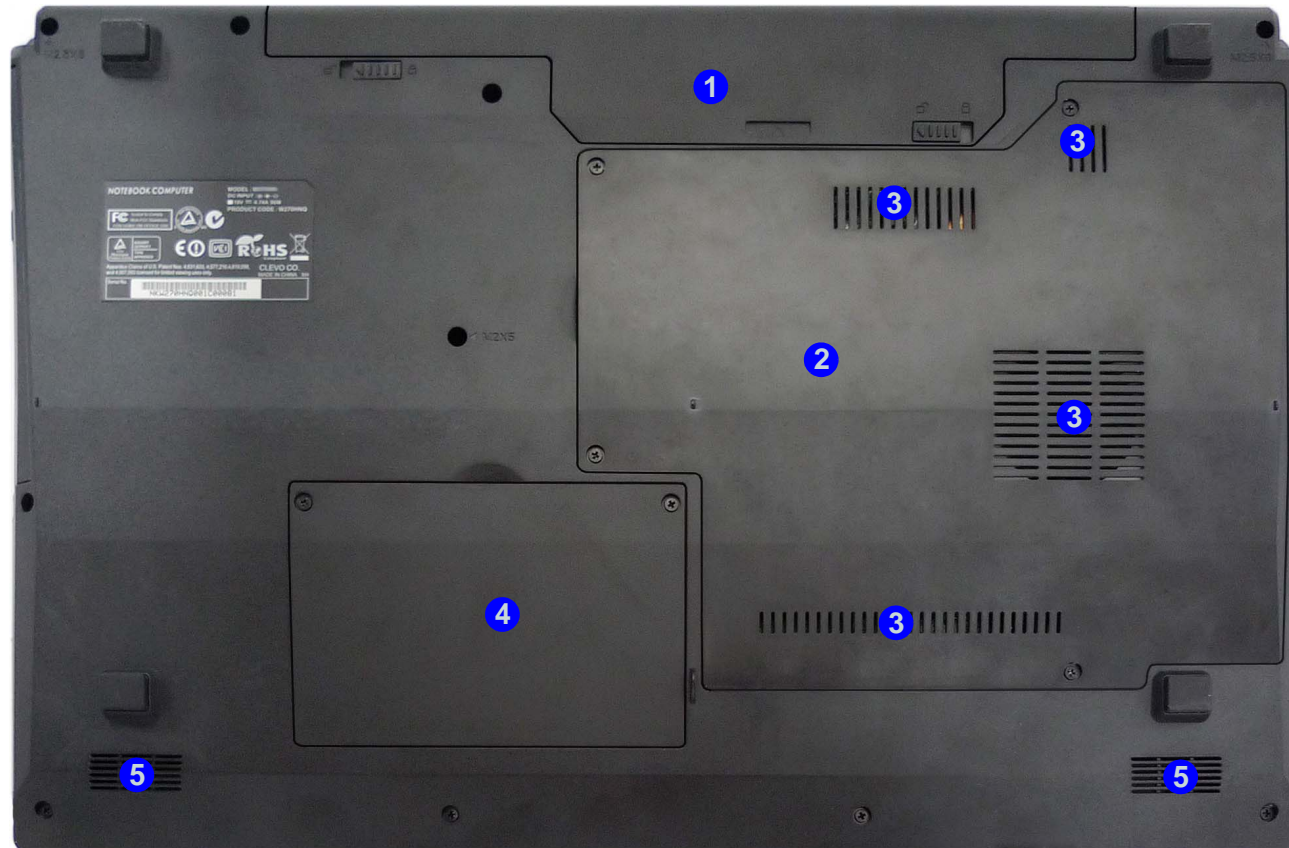

Overheating

To prevent your computer from overheating, make sure nothing blocks any vent while the computer is in use.

Mainboard Overview - Top (Key Parts)

Figure 7
**Mainboard Top
Key Parts**

1. KBC-ITE IT8518
2. VIA VT1802P
3. Realtek RTL8411-CG

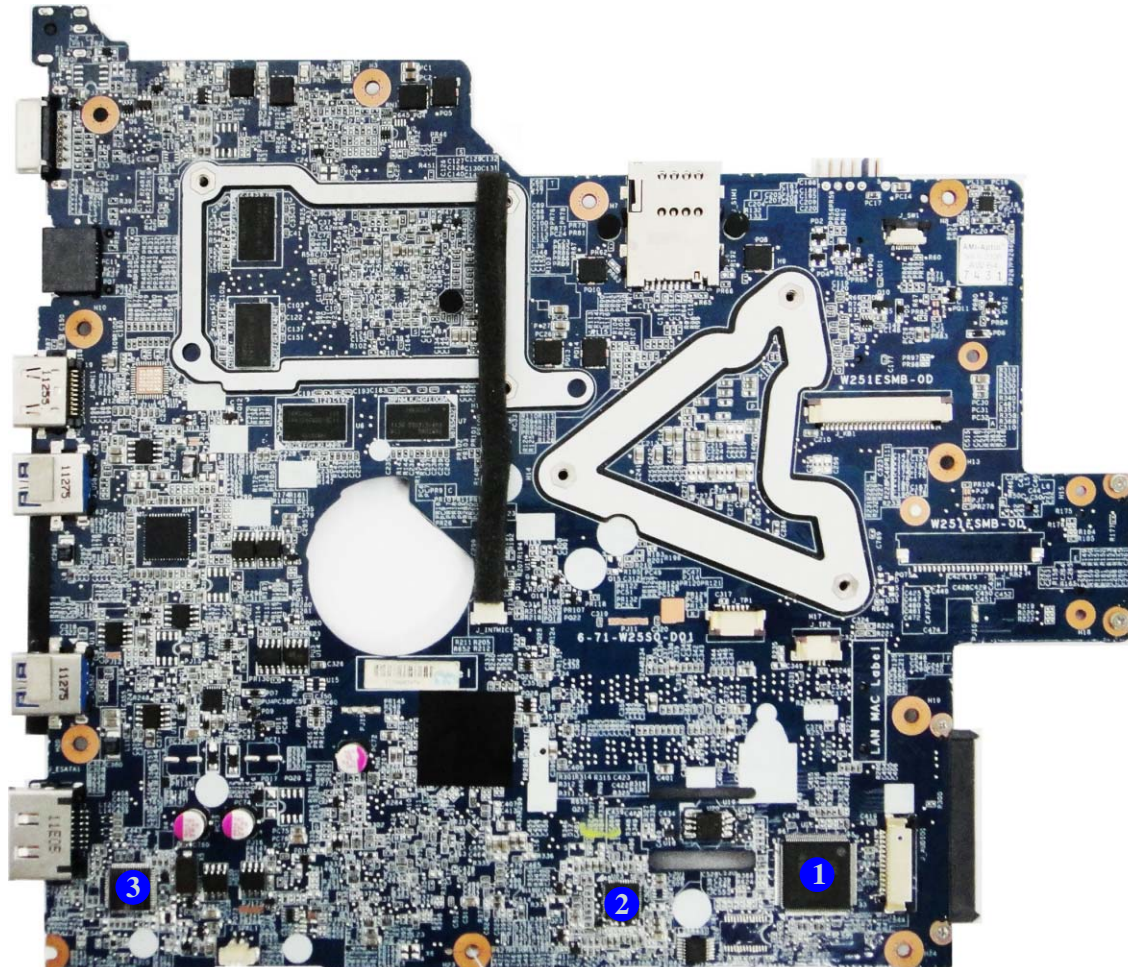

Introduction

Figure 8
**Mainboard Bottom
Key Parts**

1. Memory Slots
DDR3 SO-DIMM
2. CMOS Battery
3. Mini-Card
Connector (WLAN
Module)
4. CPU Socket (no
CPU installed)
5. nVIDIA VGA
6. Platform Controller
Hub

Mainboard Overview - Bottom (Key Parts)

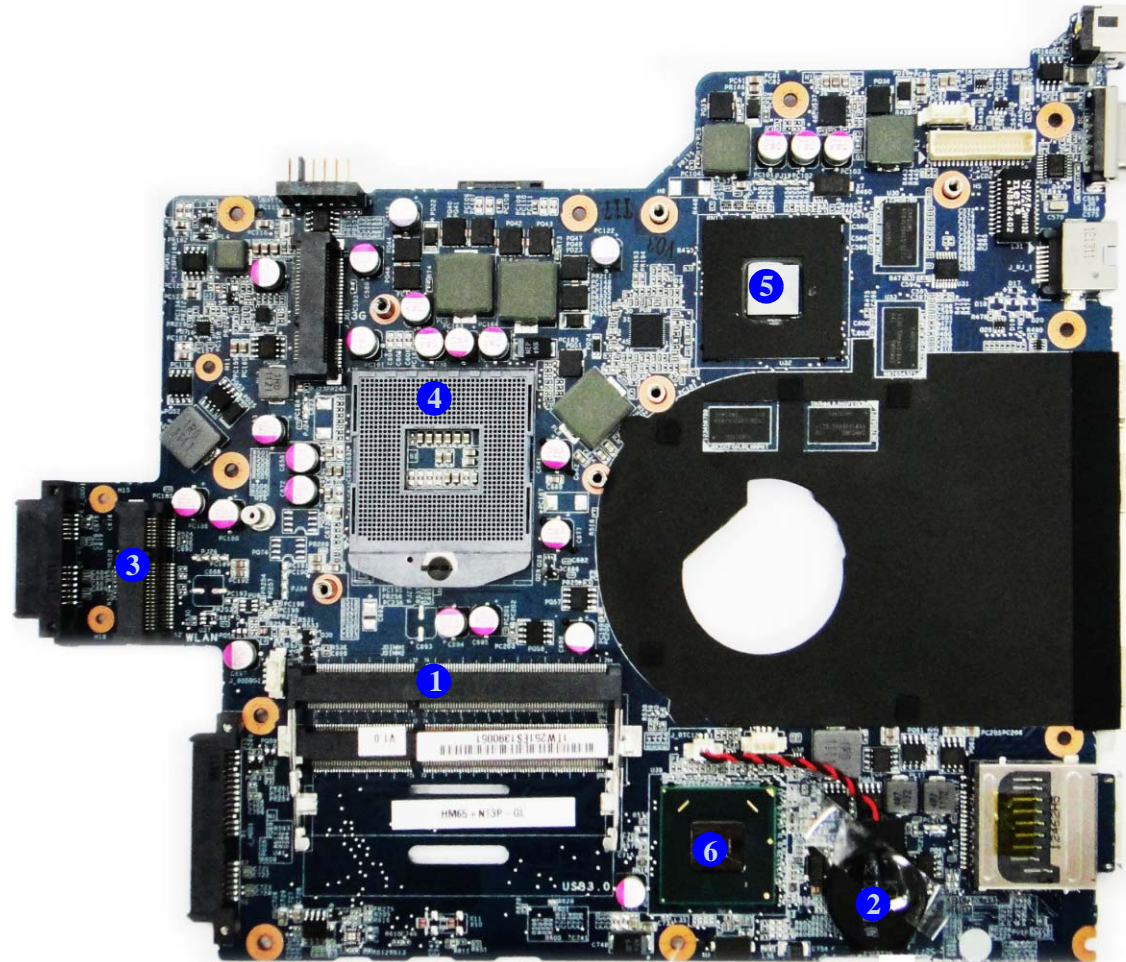

Mainboard Overview - Top (Connectors)

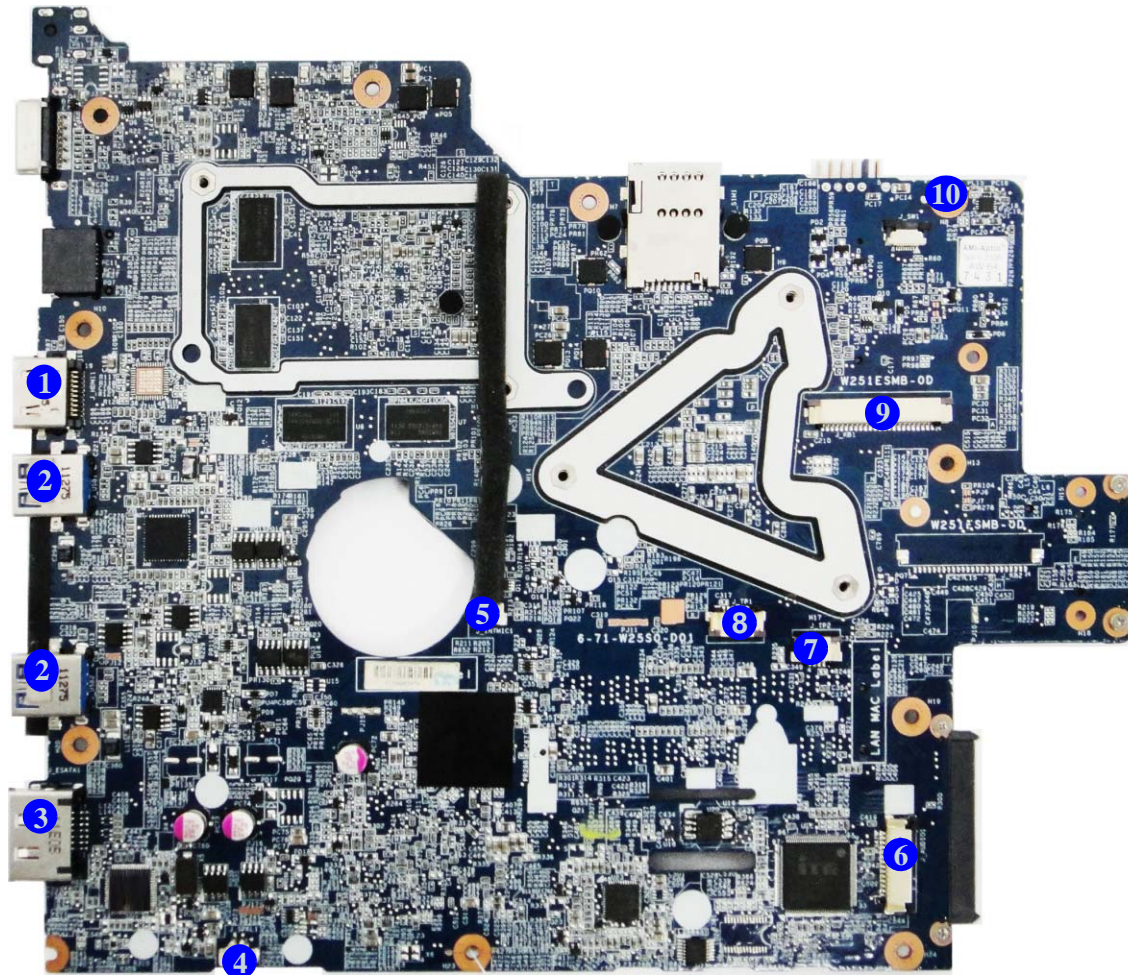

Figure 9
Mainboard Top Connectors

1. HDMI-Out Port
2. USB Port 3.0
3. eSATA Port
4. Speaker Cable Connector
5. Microphone Cable Connector
6. Audio Board Connector
7. TouchPad Cable Connector 1
8. TouchPad Cable Connector 2
9. Keyboard Cable Connector
10. Switch Board Cable Connector

Introduction

Figure 10
**Mainboard Bottom
Connectors**

1. ODD Connector
2. HDD Connector
3. CPU Fan Cable Connector
4. Multi-in-1 Card Reader
5. RJ-45 LAN Jack
6. External Monitor Port
7. DC-In Jack
8. CCD Cable Connector
9. LCD Cable Connector

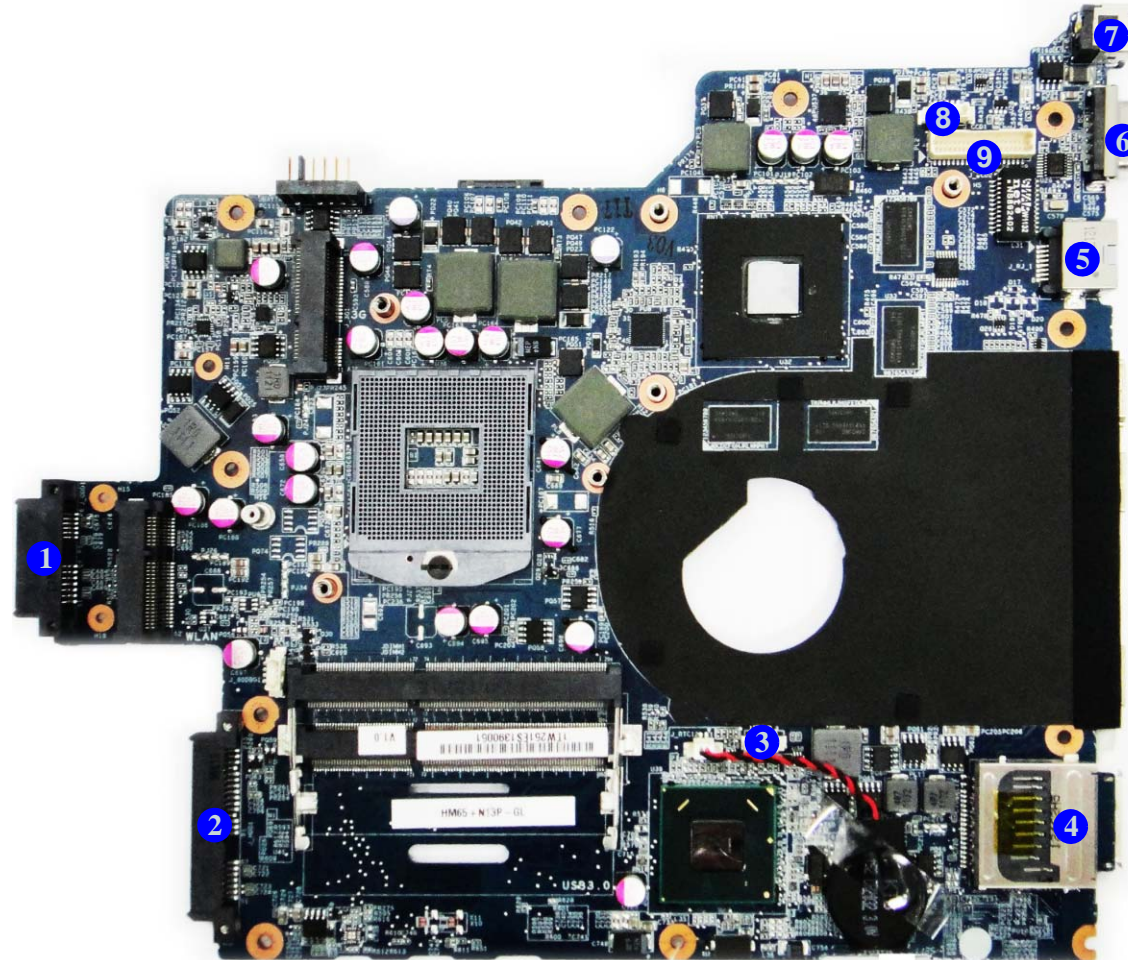

Chapter 2: Disassembly

Overview

This chapter provides step-by-step instructions for disassembling the **W270HSQ** series notebook's parts and subsystems. When it comes to reassembly, reverse the procedures (unless otherwise indicated).

We suggest you completely review any procedure before you take the computer apart.

Procedures such as upgrading/replacing the RAM, optical device and hard disk are included in the User's Manual but are repeated here for your convenience.

To make the disassembly process easier each section may have a box in the page margin. Information contained under the figure # will give a synopsis of the sequence of procedures involved in the disassembly procedure. A box with a  lists the relevant parts you will have after the disassembly process is complete. **Note:** The parts listed will be for the disassembly procedure listed ONLY, and not any previous disassembly step(s) required. Refer to the part list for the previous disassembly procedure. The amount of screws you should be left with will be listed here also.

A box with a  will also provide any possible helpful information. A box with a  contains warnings.

An example of these types of boxes are shown in the sidebar.

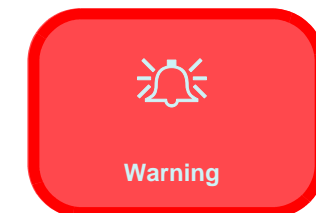
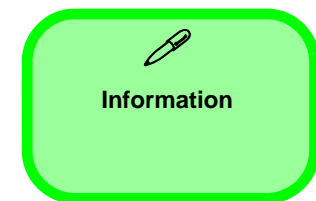

Disassembly

NOTE: All disassembly procedures assume that the system is turned **OFF**, and disconnected from any power supply (the battery is removed too).

Maintenance Tools

The following tools are recommended when working on the notebook PC:

- M3 Philips-head screwdriver
- M2.5 Philips-head screwdriver (magnetized)
- M2 Philips-head screwdriver
- Small flat-head screwdriver
- Pair of needle-nose pliers
- Anti-static wrist-strap

Connections

Connections within the computer are one of four types:

Locking collar sockets for ribbon connectors	To release these connectors, use a small flat-head screwdriver to gently pry the locking collar away from its base. When replacing the connection, make sure the connector is oriented in the same way. The pin1 side is usually not indicated.
Pressure sockets for multi-wire connectors	To release this connector type, grasp it at its head and gently rock it from side to side as you pull it out. Do not pull on the wires themselves. When replacing the connection, do not try to force it. The socket only fits one way.
Pressure sockets for ribbon connectors	To release these connectors, use a small pair of needle-nose pliers to gently lift the connector away from its socket. When replacing the connection, make sure the connector is oriented in the same way. The pin1 side is usually not indicated.
Board-to-board or multi-pin sockets	To separate the boards, gently rock them from side to side as you pull them apart. If the connection is very tight, use a small flat-head screwdriver - use just enough force to start.

Maintenance Precautions

The following precautions are a reminder. To avoid personal injury or damage to the computer while performing a removal and/or replacement job, take the following precautions:

1. **Don't drop it.** Perform your repairs and/or upgrades on a stable surface. If the computer falls, the case and other components could be damaged.
2. **Don't overheat it.** Note the proximity of any heating elements. Keep the computer out of direct sunlight.
3. **Avoid interference.** Note the proximity of any high capacity transformers, electric motors, and other strong magnetic fields. These can hinder proper performance and damage components and/or data. You should also monitor the position of magnetized tools (i.e. screwdrivers).
4. **Keep it dry.** This is an electrical appliance. If water or any other liquid gets into it, the computer could be badly damaged.
5. **Be careful with power.** Avoid accidental shocks, discharges or explosions.
 - Before removing or servicing any part from the computer, turn the computer off and detach any power supplies.
 - When you want to unplug the power cord or any cable/wire, be sure to disconnect it by the plug head. Do not pull on the wire.
6. **Peripherals** – Turn off and detach any peripherals.
7. **Beware of static discharge.** ICs, such as the CPU and main support chips, are vulnerable to static electricity. Before handling any part in the computer, discharge any static electricity inside the computer. When handling a printed circuit board, do not use gloves or other materials which allow static electricity buildup. We suggest that you use an anti-static wrist strap instead.
8. **Beware of corrosion.** As you perform your job, avoid touching any connector leads. Even the cleanest hands produce oils which can attract corrosive elements.
9. **Keep your work environment clean.** Tobacco smoke, dust or other air-borne particulate matter is often attracted to charged surfaces, reducing performance.
10. **Keep track of the components.** When removing or replacing any part, be careful not to leave small parts, such as screws, loose inside the computer.

Cleaning

Do not apply cleaner directly to the computer, use a soft clean cloth.

Do not use volatile (petroleum distillates) or abrasive cleaners on any part of the computer.



Power Safety Warning

Before you undertake any upgrade procedures, make sure that you have turned off the power, and disconnected all peripherals and cables (including telephone lines). It is advisable to also remove your battery in order to prevent accidentally turning the machine on.

Disassembly Steps

The following table lists the disassembly steps, and on which page to find the related information. **PLEASE PERFORM THE DISASSEMBLY STEPS IN THE ORDER INDICATED.**

To remove the Battery:

1. Remove the battery *page 2 - 5*

To remove the HDD:

1. Remove the battery *page 2 - 5*
2. Remove the HDD *page 2 - 6*

To remove the Optical Device:

1. Remove the battery *page 2 - 5*
2. Remove the Optical device *page 2 - 8*

To remove the System Memory:

1. Remove the battery *page 2 - 5*
2. Remove the system memory *page 2 - 9*

To remove and install a Processor:

1. Remove the battery *page 2 - 5*
2. Remove the processor *page 2 - 11*
3. Install the processor *page 2 - 13*

To remove the Wireless LAN Module:

1. Remove the battery *page 2 - 5*
2. Remove the WLAN module *page 2 - 14*

To remove the Keyboard:

1. Remove the battery *page 2 - 5*
2. Remove the keyboard *page 2 - 15*

Removing the Battery

1. Turn the computer **off**, and turn it over.
2. Slide the latch **1** in the direction of the arrow (*Figure 1a*).
3. Slide the latch **2** in the direction of the arrow, and hold it in place (*Figure 1a*).
4. Slide the battery **3** in the direction of the arrow **4** (*Figure 1b*).

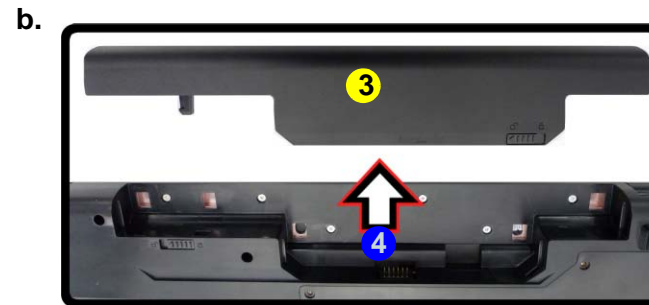
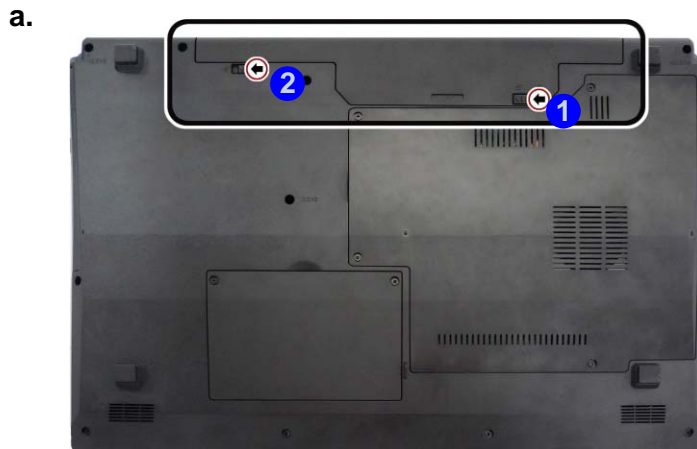
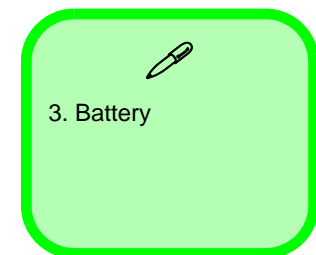

Figure 1
Battery Removal

- a. Slide the latch and hold it in place.
- b. Slide the battery in the direction of the arrow.



Removing the Hard Disk Drive

Figure 2
**HDD Assembly
Removal**

The hard disk drive can be taken out to accommodate other 2.5" serial (SATA) hard disk drives with a height of 9.5mm (h). Follow your operating system's installation instructions, and install all necessary drivers and utilities (as outlined in **Chapter 4 of the User's Manual**) when setting up a new hard disk.

- a. Locate the HDD bay cover and remove the screws.

Hard Disk Upgrade Process

1. Turn **off** the computer, and remove the battery ([page 2 - 5](#)).
2. Locate the hard disk bay cover and remove screws **1** & **2** ([Figure 2a](#)).

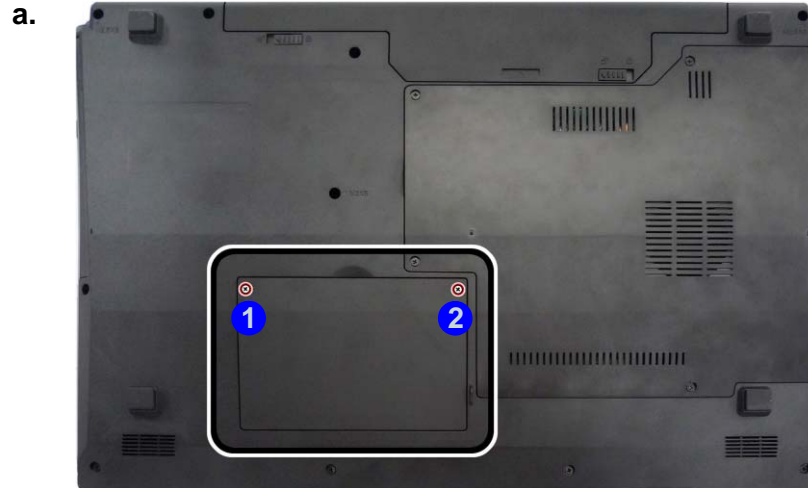

HDD System Warning

New HDD's are blank. Before you begin make sure:

You have backed up any data you want to keep from your old HDD.

You have all the CD-ROMs and FDDs required to install your operating system and programs.

If you have access to the internet, download the latest application and hardware driver updates for the operating system you plan to install. Copy these to a removable medium.



- 2 Screws

3. Remove the hard disk bay cover **3** (*Figure 3b*).
4. Grip the tab and slide the hard disk in the direction of arrow **4** (*Figure 3c*).
5. Lift the hard disk assembly **5** out of the bay **6** (*Figure 3d*).
6. Remove the screw **7** - **10** and the mylar cover **11** from the hard disk **12** (*Figure 3e*).
7. Reverse the process to install a new hard disk (do not forget to replace all the screws and covers).

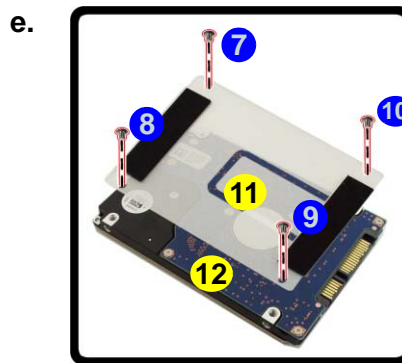
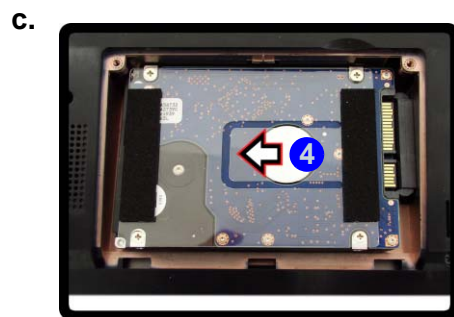
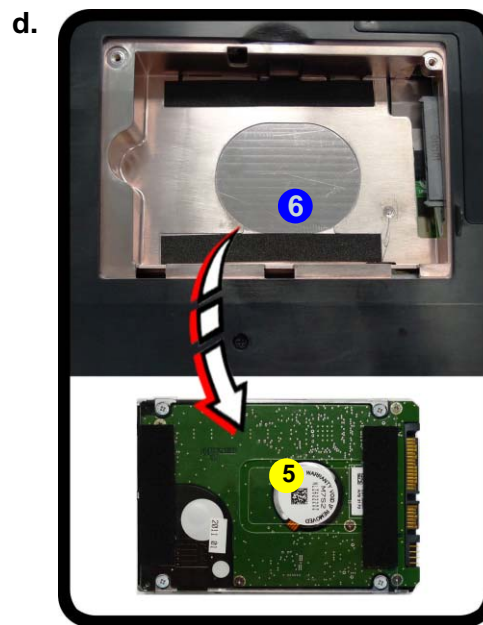
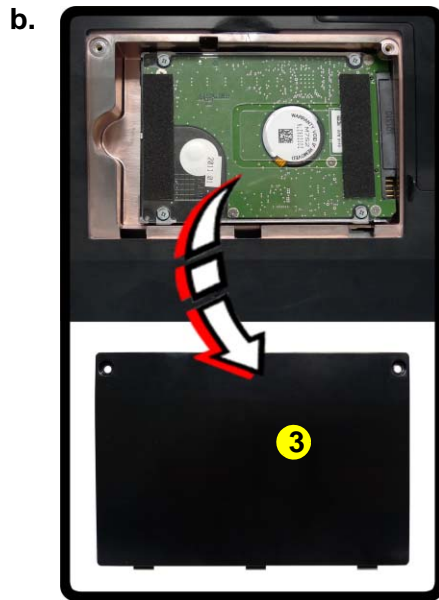

Figure 3
**HDD Assembly
 Removal (cont'd.)**

- b. Remove the HDD bay cover.
- c. Grip the tab and slide the HDD assembly in the direction of the arrow.
- d. Lift the HDD assembly out of the bay.
- e. Remove the screws and mylar cover.



- 3. HDD Bay Cover
- 5. HDD Assembly
- 11. Mylar Cover
- 12. HDD
- 4 Screws

Disassembly

Figure 4 Optical Device Removal

- a. Remove the screw at point ①.
- b. Use a screwdriver to carefully push out the optical device at point ②.

Removing the Optical (CD/DVD) Device

1. Turn **off** the computer, remove the battery ([page 2 - 5](#)) and hard disk ([page 2 - 6](#)).
2. Remove the screw at point ① ([Figure 4a](#)).
3. Use a screwdriver to carefully push out the optical device ③ at point ② ([Figure 4b](#)).
4. Insert the new device and carefully slide it into the computer (the device only fits one way. **DO NOT FORCE IT**; The screw holes should line up).
5. Replace the hard disk bay cover.
6. Restart the computer to allow it to automatically detect the new device.

a.



b.

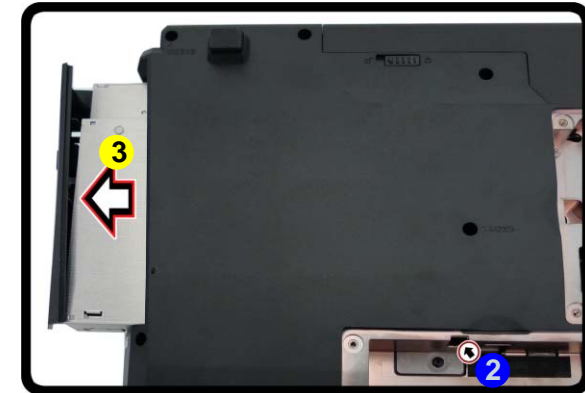

3. Optical Device

- 1 Screw

Removing the System Memory (RAM)

The computer has two memory sockets for 204 pin Small Outline Dual In-line Memory Modules (SO-DIMM) supporting DDRIII (DDR3) Up to 1066/1333 MHz. The main memory can be expanded up to 8GB. The SO-DIMM modules supported are 1024MB and 2048MB **DDRIII** Modules. The total memory size is automatically detected by the POST routine once you turn on your computer.

Memory Upgrade Process

1. Turn **off** the computer, turn it over and remove the battery ([page 2 - 5](#)).
2. Remove screws **1** - **4** from the component bay cover ([Figure 5a](#)).
3. Carefully (**a fan and cable are attached to the under side of the cover**) lift up the bay cover **5**.
4. Carefully disconnect the fan cable **6**, and remove the cover **5** ([Figure 5b](#)).
5. The RAM modules will be visible at point **7** on the mainboard.

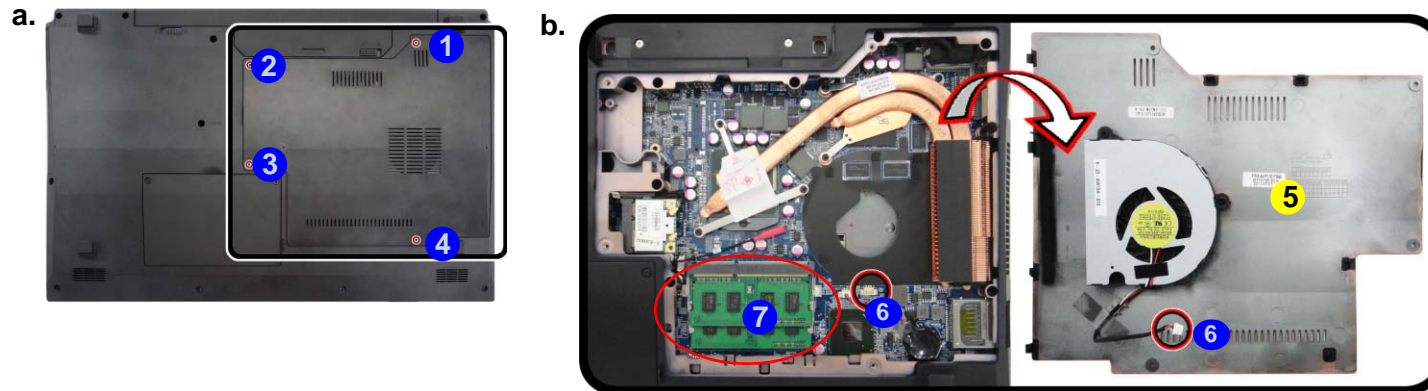

Figure 5
RAM Module Removal

- a. Remove the screws from the component bay cover.
- b. The RAM modules will be visible at point **5** on the mainboard.
- c. Pull the release latches.
- d. Remove the module.



Contact Warning

Be careful not to touch the metal pins on the module's connecting edge. Even the cleanest hands have oils which can attract particles, and degrade the module's performance.



5. Component Bay Cover

- 4 Screws

Disassembly

Figure 6
**RAM Module
 Removal (cont'd)**

- c. Pull the release latches.
 d. Remove the module.
 e. Replace bay cover.

6. Gently pull the two release latches (8 & 9) on the sides of the memory socket in the direction indicated by the arrows (Figure 6c). The RAM module 10 will pop-up (Figure 6d), and you can then remove it.
7. Pull the latches to release the second module if necessary.
8. Insert a new module holding it at about a 30° angle and fit the connectors firmly into the memory slot.
9. The module will only fit one way as defined by its pin alignment. Make sure the module is seated as far into the slot as it will go. **DO NOT FORCE IT**; it should fit without much pressure.
10. Press the module in and down towards the mainboard until the slot levers click into place to secure the module.
11. Replace the bay cover (Figure 6e) and the screws (**make sure you reconnect the fan cable before screwing down the bay cover**).
12. Restart the computer to allow the BIOS to register the new memory configuration as it starts up.

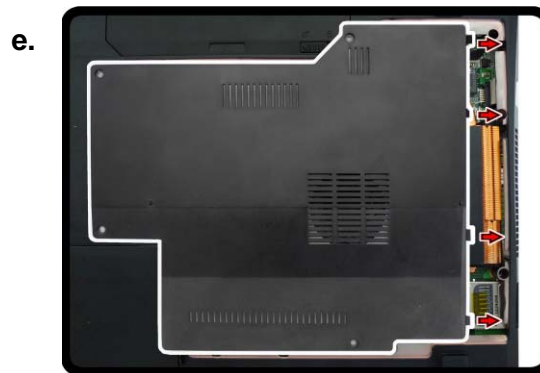
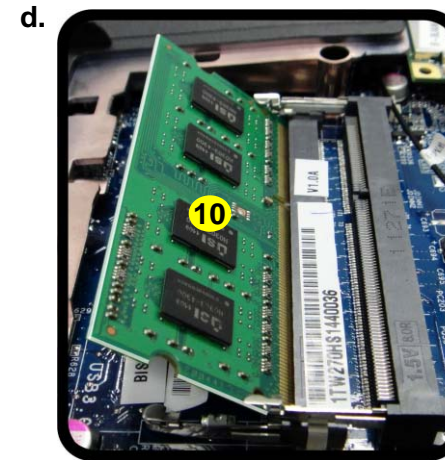
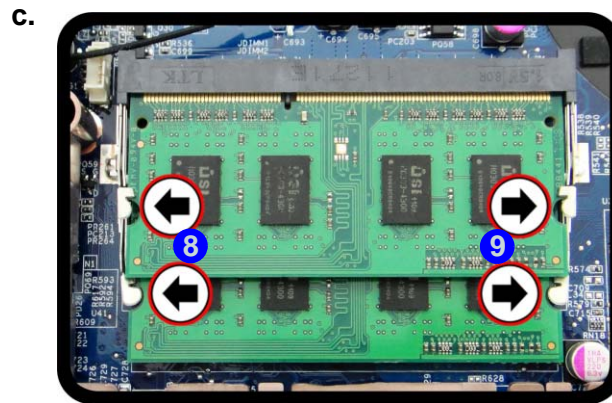

Contact Warning

Be careful not to touch the metal pins on the module's connecting edge. Even the cleanest hands have oils which can attract particles, and degrade the module's performance.



10. RAM



Cover Pins

Note that this computer model has **four** cover pins. These pins need to be aligned with slots in the case to insure a proper cover fit, before screwing down the bay cover.

Removing and Installing a Processor

Processor Removal Procedure

1. Turn **off** the computer, turn it over, and remove the battery ([page 2 - 5](#)) and the component bay cover ([page 2 - 9](#)).
2. The CPU heat sink will be visible at point **A** ([Figure 7a](#)).
3. Loosen the CPU heat sink screws in the order **6**, **5**, **4**, **3**, **2** & **1** (the reverse order as indicated on the label [Figure 7a](#)).
4. Grip the heat sink tab and carefully lift the heat sink **7** up and off the computer ([Figure 7b](#)).

Figure 7
Processor Removal

- a. The CPU heat sink will be visible at point **A**. Remove the screws from the CPU heatsink.
- b. Grip the heat sink tab and carefully lift the heat sink up and off the computer.

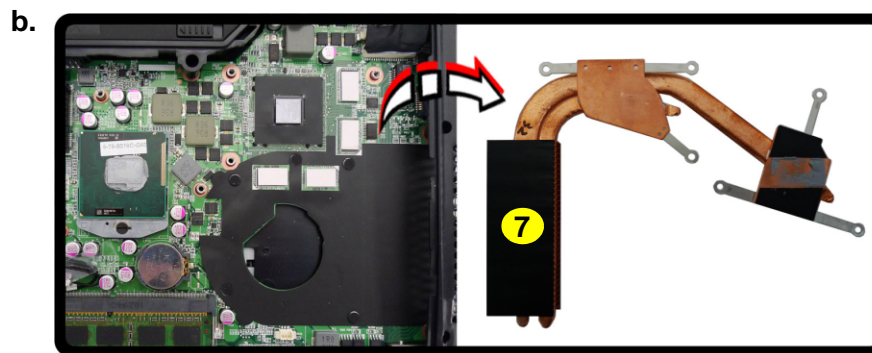
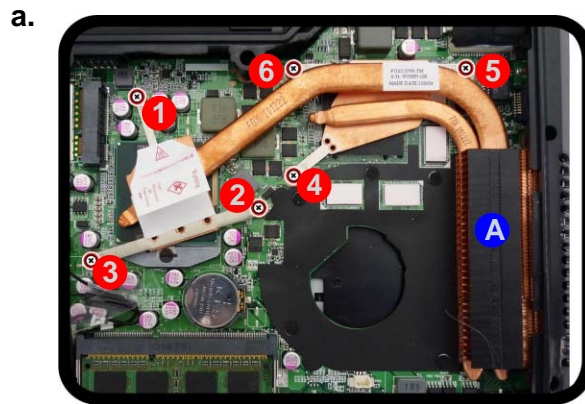



7. Heat Sink

- 6 Screws

Disassembly

Figure 8 Processor Removal (cont'd)

- c. Turn the release latch to unlock the CPU.
d. Lift the CPU out of the socket.

5. Turn the release latch **5** towards the unlock symbol  to release the CPU (**Figure 8d**).
6. Carefully (it may be hot) lift the CPU **6** up and out of the socket (**Figure 8e**).
7. Reverse the process to install a new CPU.
8. When re-inserting the CPU, pay careful attention to the pin alignment, it will fit only one way (DO NOT FORCE IT!).

c.

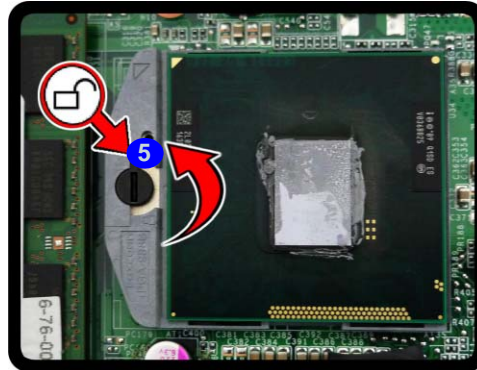

Unlock

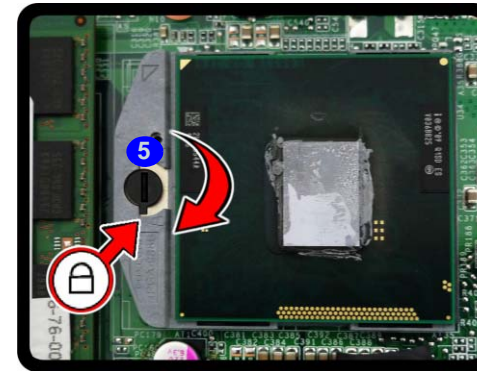

Lock

d.

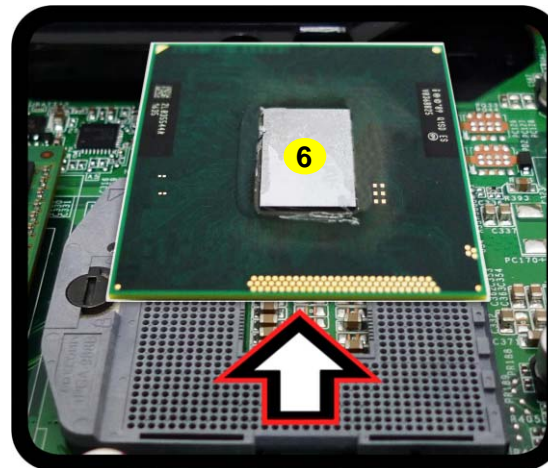

Caution

The heat sink, and CPU area in general, contains parts which are subject to high temperatures. Allow the area time to cool before removing these parts.

6. CPU

Processor Installation Procedure



1. Insert the CPU **A** (*Figure 9a*), pay careful attention to the pin alignment, it will fit only one way (DO NOT FORCE IT!), and turn the release latch **B** towards the lock symbol  (*Figure 9b*).
2. **Remove the sticker C** (*Figure 9c*) from the heat sink.
3. Insert the heat sink **D** as indicated in *Figure 9d*.
4. Tighten the CPU heat sink screws in the order **1**, **2**, **3**, **4**, **5** & **3** (the order as indicated on the label and *Figure 9d*).
5. Replace the component bay cover (don't forget to replace the fan cable) and tighten the screws (*page 2 - 9*).

Figure 9
Processor Installation

- a. Insert the CPU.
- b. Turn the release latch towards the lock symbol.
- c. Remove the sticker from the heat sink and insert the heat sink.
- d. Tighten the screws.

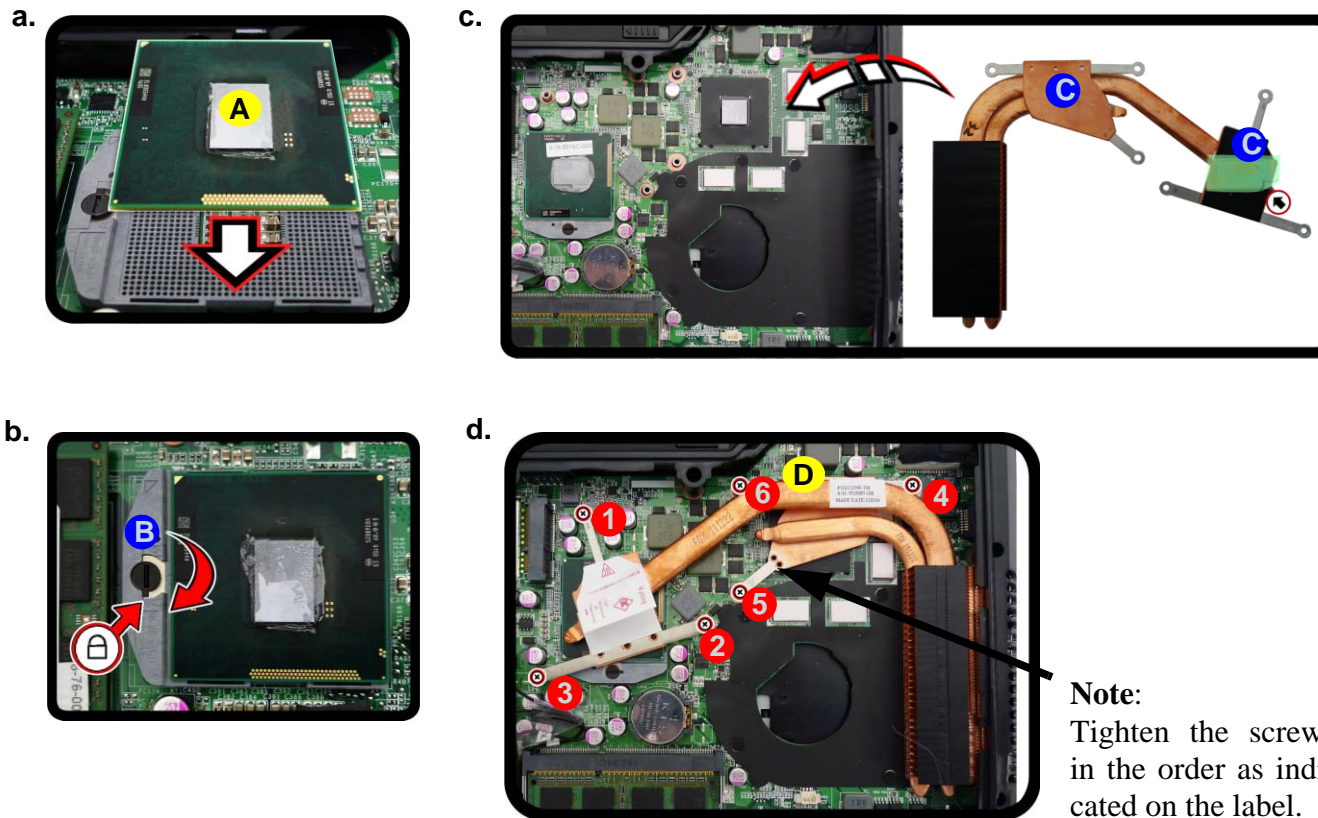

Note:
Tighten the screws in the order as indicated on the label.



A. CPU
D. Heat Sink

- 3 Screws

Disassembly

Figure 10 Wireless LAN Module Removal

- Locate the WLAN.
- Disconnect the cable and remove the screw.
- The WLAN module will pop up.

Note: Make sure you reconnect the antenna cable to the “1 + 2” socket (Figure 10b).

Removing the Wireless LAN Module

- Turn **off** the computer, turn it over, and remove the battery (page 2 - 5) and the component bay cover (page 2 - 9).
- The Wireless LAN module will be visible at point ① on the mainboard (Figure 10a).
- Carefully disconnect the cables ② - ③, and then remove the screw ④ (Figure 10b).
- The Wireless LAN module ④ (Figure 10c) will pop-up, and you can remove it from the computer.

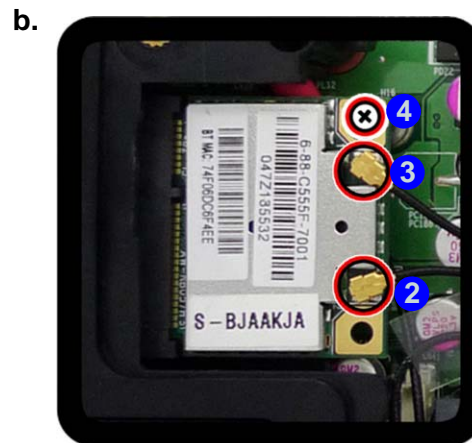
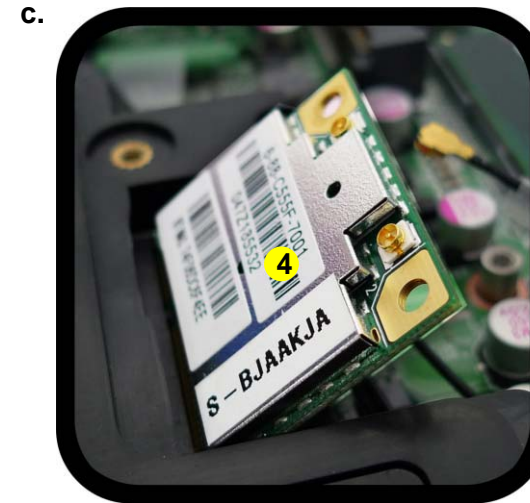
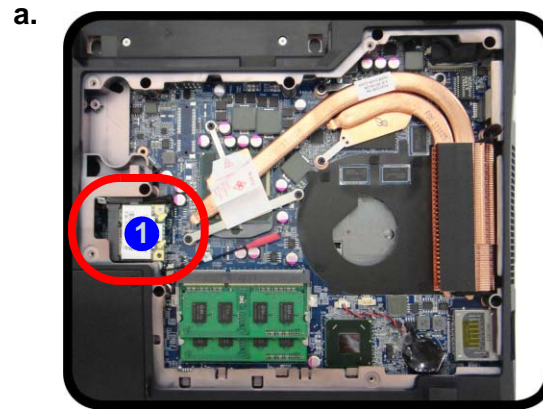

4. Wireless LAN Module

- 2 Screw

Removing the Keyboard

1. Turn **off** the computer, and remove the battery ([page 2 - 5](#)).
2. Remove screws **1** - **2** from the bottom of the computer (inside the battery compartment), and then press at point **3** to unsnap the LED cover module (use the eject pin tool provided to do this [Figure 11a](#)).
3. Turn the computer over, unsnap up the LED cover module **4** from the center of the computer ([Figure 11b](#)).
4. Remove screws **5** - **9** from the keyboard ([Figure 11c](#)).
5. Carefully lift the keyboard **10** up, being careful not to bend the keyboard ribbon cable **11**. Disconnect the keyboard ribbon cable **11** from the locking collar socket **12** by using a flat-head screwdriver to pry the locking collar pins **13** away from the base ([Figure 11d](#)).
6. Carefully lift up the keyboard **10** ([Figure 11d](#)) off the computer.

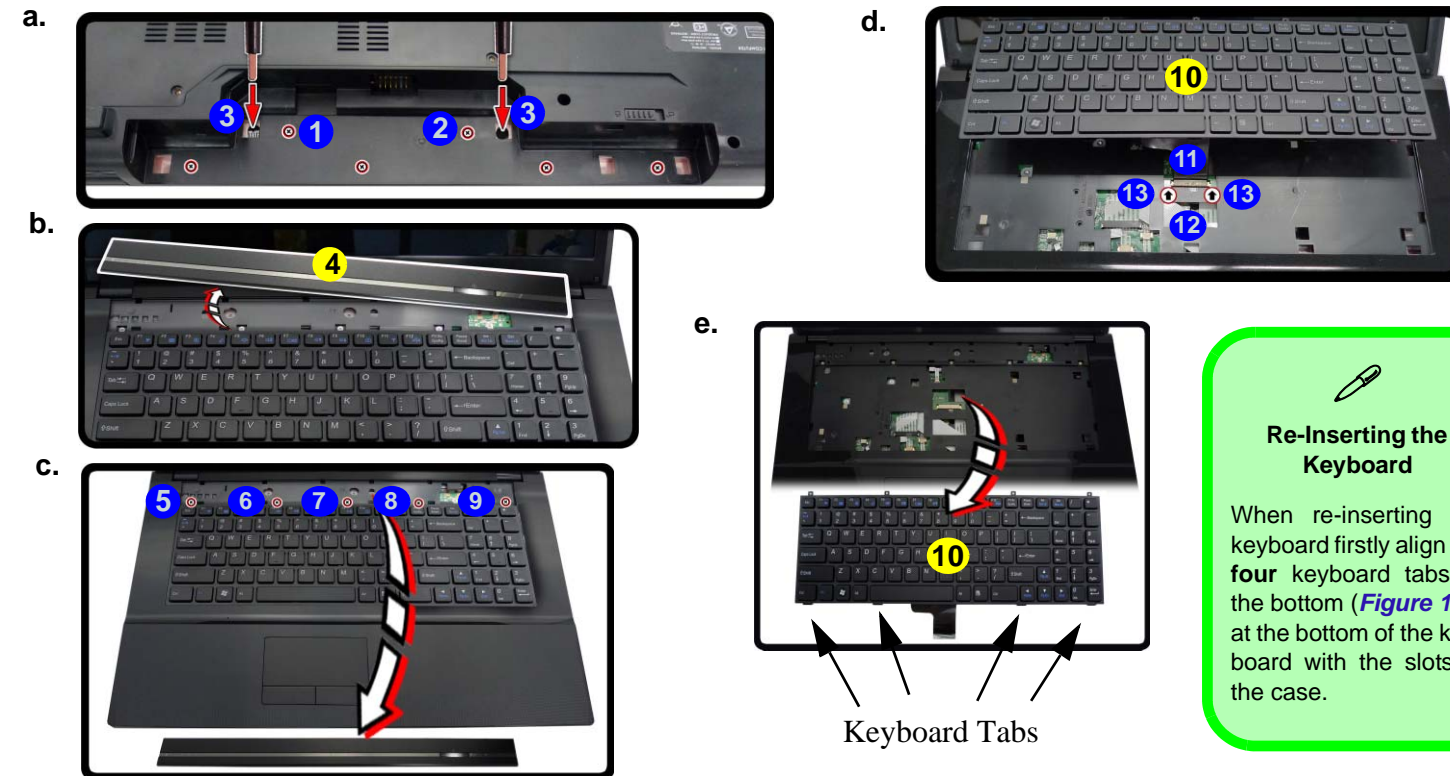

Re-Inserting the Keyboard

When re-inserting the keyboard firstly align the **four** keyboard tabs at the bottom ([Figure 11e](#)) at the bottom of the keyboard with the slots in the case.

- 4. LED Cover Module
- 10. Keyboard
- 7 Screws

Figure 11
Keyboard Removal

- a. Remove screws from the bottom of the computer.
- b. Turn the computer over, unsnap up the LED cover module from the center of the computer.
- c. Remove screws from the keyboard.
- d. Carefully lift the keyboard up and disconnect the keyboard ribbon cable from the locking collar socket by using a flat-head screwdriver to pry the locking collar pins away from the base.
- e. Remove the keyboard.

Appendix A:Part Lists

This appendix breaks down the *W270HSQ* series notebook's construction into a series of illustrations. The component part numbers are indicated in the tables opposite the drawings.

Note: This section indicates the *manufacturer's* part numbers. Your organization may use a different system, so be sure to cross-check any relevant documentation.

Note: Some assemblies may have parts in common (especially screws). However, the part lists DO NOT indicate the total number of duplicated parts used.

Note: Be sure to check any update notices. The parts shown in these illustrations are appropriate for the system at the time of publication. Over the product life, some parts may be improved or re-configured, resulting in *new* part numbers.

Part List Illustration Location

The following table indicates where to find the appropriate part list illustration.

Table A - 1
**Part List Illustration
Location**

Part	W270HSQ
Top	<i>page A - 3</i>
Bottom	<i>page A - 4</i>
SATA BLU RAY COMBO	<i>page A - 5</i>
DVD Dual Drive	<i>page A - 6</i>
LCD	<i>page A - 7</i>

Top

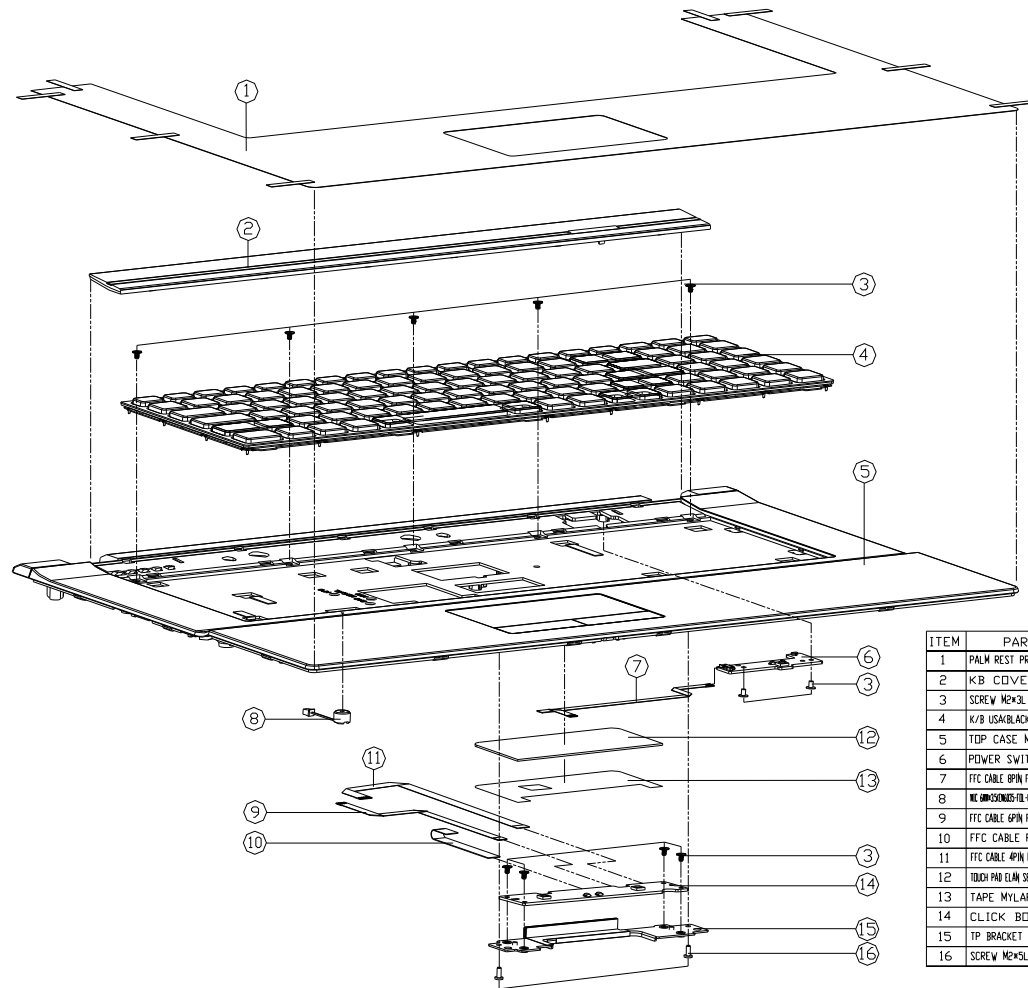
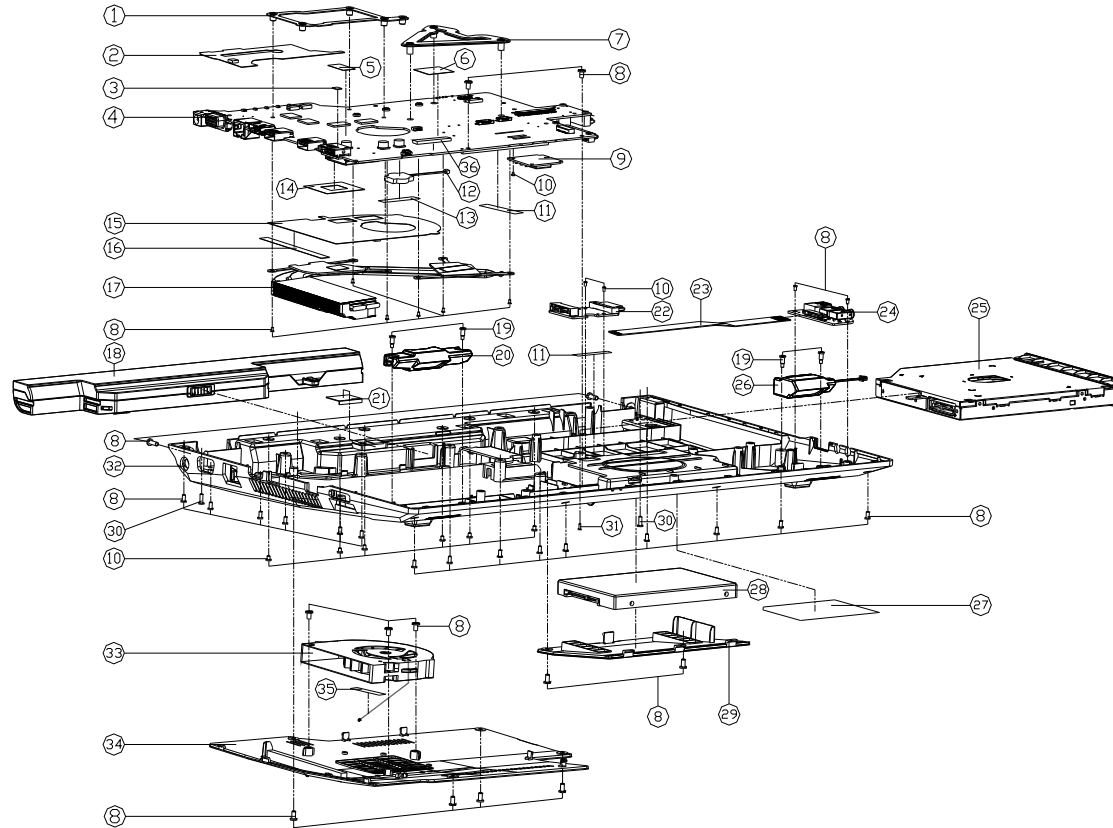

Figure A - 1
Top

ITEM	PART NAME	PART NO	REMARK
1	PALM REST PROTECT NYLAR (8835) W270HJ0	6-40-W27H8-011	
2	KB COVER MODULE W270HJ0	6-42-W27H8-102	
3	SCREW M2x3L KI NI ICT NY (DD=45,DT=04)	6-35-B1120-3RE	
4	K/B US/BLACK FRAME/US MODULE W270HJ0	6-79-W270HJ0K-010	
5	TOP CASE MODULE(CHANGE) W270HJ0	6-39-W27H2-014	
6	POWER SWITCH BOARD V1.0A W270HJ0	6-77-W25PS-D11A-A	
7	FFC CABLE 6PIN FOR W/B TO POWER BOARD 010 W270HJ0	6-43-W27H0-041-2	
8	FFC CABLE 6PIN FOR W/B TO CLICK BOARD (OR 6PIN 400 W270HJ0)	6-23-EM54G-012-2	
9	FFC CABLE 6PIN FOR W/B TO CLICK BOARD 010 W270HJ0	6-43-W27N0-011-2	
10	FFC CABLE FOR TOUCH PAD 6PIN C4500	6-43-C4502-010-2	
11	FFC CABLE 4PIN FOR W/B TO CLICK BOARD 010 W270HJ0	6-43-W27S0-010-1	
12	TOUCH PAD ELIM 38428-600 MULTI-FINGER GESTURE W250HJ0	6-49-W25A2-011	
13	TAPE NYLAR (C) (86*38.80MM) C4105	6-40-00150-861	
14	CLICK BOARD V2.0A W251HJ0	6-77-W25P2-D02A	
15	TP BRACKET MIDDLE (SECC 0.8T) W270HJ0	6-33-W27H2-101	
16	SCREW M2xSL KI(CT=08 D=40) BK/Z ICT NY	6-35-B6120-5R0	

Bottom

Figure A - 2
Bottom



ITEM	PART NAME	PART NO	REMARK
1	VGA SUPPORTER SECC	W27630	6-33-W2733-010
2	W/ BLUR HOLES/NO-DRIVE/NO-DRIVE VESDA	6-40-W25PS-200	
3	GASKET (RIBBED) FOR DC JACK TRFN	6-47-00190-08E	
4	MAIN BOARD VES QV5 ZOM/NOVIA ID VES150	6-77-W2750-DN2-1	
4	MAIN BOARD VES QV5 3D V27630	6-77-W2750-DN1-1	
4	MAIN BOARD VES QV5 3D Q2D V27630	6-77-W2750-DN1-3P	
4	MAIN BOARD VES QV5 3D V27630	6-77-W2750-DN1-1	
5	MYLAR KB BRIDGE 100 PCT V27630	6-40-W2747-010	
6	AUDIO BOARD VES QV5 (100) R/0/0/0/0/0	6-40-C4505-030	
7	CPU SUPPORT BRACKET SECC VES150	6-33-W25PS-013	
8	SCREW M2.5x5L KI BK/ZZ ICT NY	6-35-B6125-SRA	
9	Label (bottom) for the bottom of the device	6-88-W345P-1450	(OPTION)
9	Label (bottom) for the bottom of the device	6-88-W2940-9450	(OPTION)
9	Label (bottom) for the bottom of the device	6-88-C555F-5300	(OPTION)
9	Label (bottom) for the bottom of the device	6-88-W76C2-700	(OPTION)
9	Label (bottom) for the bottom of the device	6-88-C555F-700	(OPTION)
9	Label (bottom) for the bottom of the device	6-88-W1108-S300	(OPTION)
9	Label (bottom) for the bottom of the device	6-88-W1108-3450	(OPTION)
9	Label (bottom) for the bottom of the device	6-88-P17EF-4200	(OPTION)
9	Label (bottom) for the bottom of the device	6-88-W25SF-4200	(OPTION)
9	Label (bottom) for the bottom of the device	6-88-W76C2-4220	(OPTION)
10	SCREW M2x4 KI NY ICT NY 008x4.01-04	6-35-B1120-3RE	
11	TAPE MYLAR (30)MYLAR MSS0J	6-40-M55J2-020	
12	MYLAR (20)MYLAR MSS0J	6-23-22015-1TC0	
13	TAPE MYLAR (C)MYLAR MSS0J	6-40-M55J2-030	
14	VGA CAP W/BLUR/NO-DRIVE/NO-DRIVE	6-40-M865J2-091	
15	MYLAR (10)MYLAR MSS0J	6-40-W25PS-400	
16	AUDIO BRIDGE 100 PCT VES150	6-47-0019A-807	
17	CRACKER KEYBOARD W/BLUR/NO-DRIVE	6-31-W275N-101	
18	MYLAR (10)MYLAR MSS0J	6-87-W24ES-4V4	(OPTION)
18	MYLAR (10)MYLAR MSS0J	6-87-E412S-4D7A	(OPTION)
18	MYLAR (10)MYLAR MSS0J	6-87-C480S-4G4B	(OPTION)
19	SCREW M2x2.5 NY ICT NY FOR SPEAKER	6-35-Z1120-6R2	
20	PHYSICAL LABEL FOR THE BOTTOM OF THE DEVICE	6-23-W25SP-020-2	
21	MYLAR (10)MYLAR MSS0J	6-40-W27H3-120	
22	BRIDGE 000 BOARD VES V27630	6-77-W25P8-00A-A	
23	MYLAR (10)MYLAR MSS0J	6-43-W2780-010-1	
24	AUDIO BOARD V208 W251E50	6-77-W25P8-00B-A	
25	SATA BLU-RAY CD/DVD ASSY (OPTION)	6-79-W27630V-080	
25	SATA DVD SUPER MULTI ASSY (OPTION)	6-79-W276500-000	
25	W/D DVD ASSY V27630 (OPTION)	6-79-W276002-000	
25	SATA BLU-RAY CD/DVD ASSY V27630 (OPTION)	6-79-W27600V-010-2	
26	PHYSICAL LABEL FOR THE BOTTOM OF THE DEVICE	6-23-W25SP-010-2	
27	PRODUCT LABEL FOR W27630	6-45-W27630-010	
27	PRODUCT LABEL FOR W27630	6-45-W27630-010	
27	PRODUCT LABEL FOR W27630	6-45-W27630-010	
27	PRODUCT LABEL FOR W27630	6-45-W27630-010	
28	W/D HDD ASSY E51200	6-79-E51800J-080	
28	W/D HDD ASSY E51200	6-79-E51800J-010	
28	W/D HDD ASSY C4800	6-79-C48000J-080	
29	HDD COVER FC-MISS V27630	6-42-W2741-011	
30	SCREW M2.5x5L KI BK/ZZ NY ICT	6-35-B6125-8R0	
31	SCREW M2x4 KI/08 B/4D BK/ZZ NY ICT	6-35-B6120-SR0	
32	BOTTOM CASE MIDDLE ASSY V27630	6-39-W27H3-013	
33	Label (bottom) for the bottom of the device	6-23-AV15H-010	
34	CPU COVER MIDDLE V27630	6-42-W2763-101	
35	TAPE MYLAR (30)MYLAR MSS0J	6-40-M55J2-010	
36	RUBBER G.23W54H6.6 V27630	6-47-W2752-010	

SATA BLU RAY COMBO

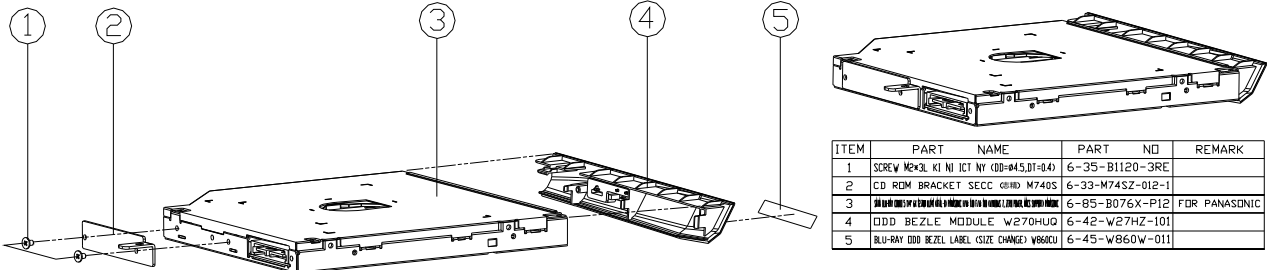

ITEM	PART NAME	PART NO	REMARK
1	SCREW M2x0.4 KI NI ICT NY (00-045,01-04)	6-35-B1120-3RE	
2	CD ROM BRACKET SECC (0HD M740S	6-33-M74SZ-012-1	
3	ODD BEZEL MODULE W270HUQ	6-85-B076X-F12	FOR PANASONIC
4	ODD BEZEL MODULE W270HUQ	6-42-W27HZ-101	
5	BLU-RAY ODD BEZEL LABEL (SIZE CHANGE) W860U	6-45-W860W-011	

Figure A - 3
SATA BLU RAY
COMBO

DVD DUAL

Figure A - 4
DVD DUAL

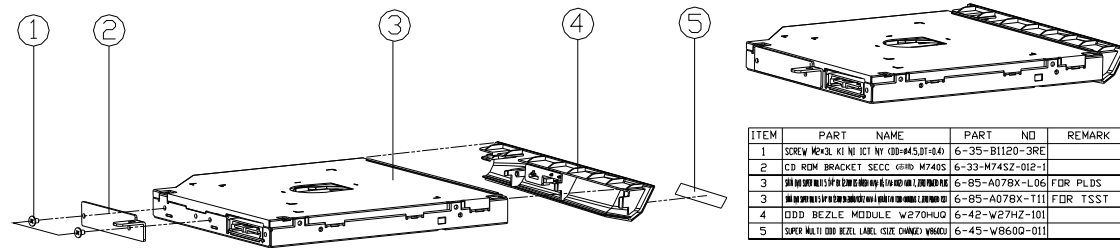

ITEM	PART NAME	PART NO	REMARK
1	SCREW M2xL KI NI JCT NY (DD-#45,01-84)	6-35-B1120-3RE	
2	CD ROM BRACKET SECC GRND M7405	6-33-M745Z-012-1	
3	ODD BEZEL MODULE W270H100 (FOR PLDS)	6-85-A078X-L06	FOR PLDS
3	ODD BEZEL MODULE W270H100 (FOR TSST)	6-85-A078X-T11	FOR TSST
4	ODD BEZLE MODULE W270H100	6-42-W27HZ-101	
5	SUPER MULTI ODD BEZEL LABEL (SIDE CHANGED) W8600	6-45-W8600-011	

LCD

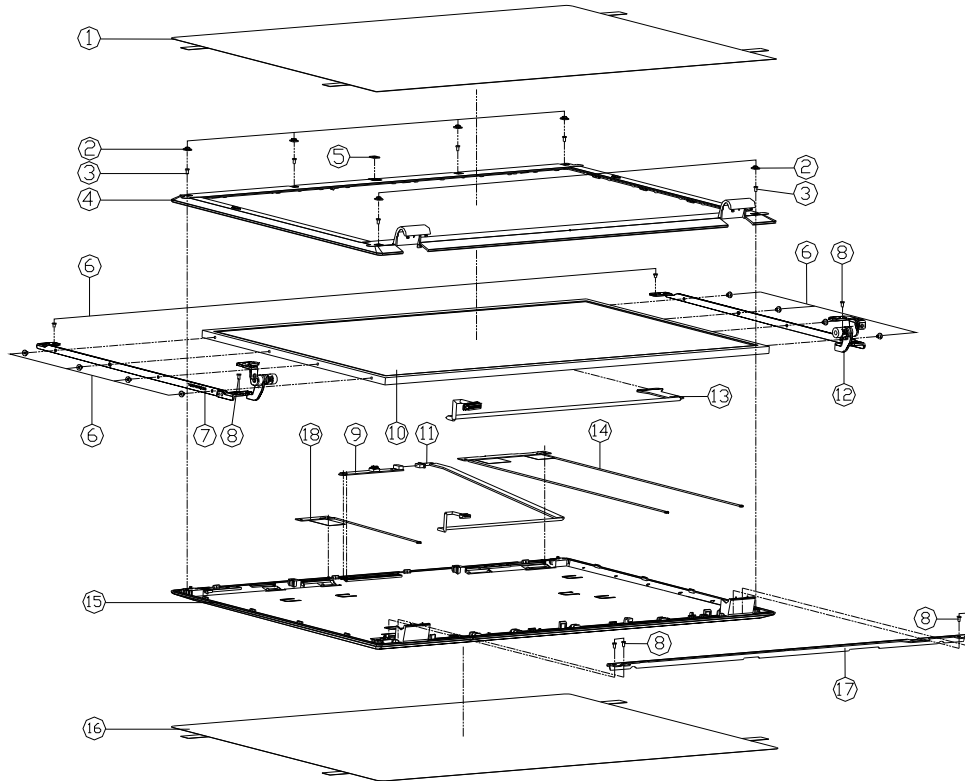

Figure A - 5
LCD

ITEM	PART NAME	PART NO	REMARK
1	LCD FRONT CASE PROTECT MYLAR PET 0710	6-40-B7118-012	
2	LCD COVER SCREW RUBBER SLICIN W270HU0	6-47-W27H8-020	
3	SCREW M2.5xSL KI BK/Z ICT NY	6-35-B6125-5RA	
4	LCD FRONT COVER MODULE W270HU0	6-39-W27H1-011	
5	CCD LENS PMMA W270HU0	6-40-W27H1-060	
5	W/O CCD LENS PMMA W270HU0	6-40-W27H1-070	
6	SCREW M2xL KI NI ICT NY (00=445.01=84)	6-35-B1120-3RE	
7	LCD HINGE L K7 W270HU0	6-33-W27H1-021	
8	SCREW M2xSL KKT=08 D=40 BK/Z ICT NY	6-35-B6120-5R0	
9	UVC CAMERA BISON FIX 0608053-00 1.3M 6AA W250UC	6-88-W250C-4900	OPTION
9	UVC CAMERA CHECKY FIX 0608053-00 1.3M 6AA W250UC	6-88-W250C-5100	OPTION
9	UVC CAMERA BISON FIX 0608053-200 1.3M 6AA W260HU0	6-88-E510C-4904	OPTION
9	UVC CAMERA BISON FIX 0608053-200 1.3M 6AA W250UC	6-88-E510C-4902	OPTION
9	UVC CAMERA BISON FIX 0608053-000 2M HIMALAYSA P550M	6-88-X510C-4900	OPTION
9	UVC CAMERA BISON FIX 0608053-000 VIO 015X5 300K W100	6-88-W150C-5100	OPTION
10	LCD 17.3" FHD CHIMET NOT3AGE-L11 QLED: 6.0 MM	6-50-NB260-D01	OPTION
10	LCD 17.3" HD+ AU 81730V01 V2 WWSA QLED: 5.8MM	6-50-NA158-G00	OPTION
10	LCD 17.3" HD+ CHIMET NOT3AGE-L12 QLED: 5.8MM	6-50-NA158-D00	
10	LCD 17.3" HD+ LG LP173W01-TL03 QLED: 6.0 MM	6-50-NA160-L02	
10	LCD 17.3" FHD HANGKAR 808730W1-A QLED: 5.8 MM	6-50-NB258-N00	
10	LCD 17.3" FHD LG LP173W01-TL01 QLED: 5.8MM	6-50-NB260-L00	
11	WIRE CABLE FOR CCD SP 436MM GOLD FOR W270HU0	6-43-W27HT-010	
12	LCD HINGE R K7 W270HU0	6-33-W27H1-011	
13	WIRE CABLE FOR LIVE 33MM FIVE CORE CONDUCTOR W270HU0	6-43-W27P1-010-E	
14	WIRE CABLE FOR LIVE 33MM FIVE CORE CONDUCTOR W270HU0	6-23-7W25P-020	
15	LCD BACK COVER MODULE W270HU0	6-39-W27H1-021	
16	BACK COVER PROTECT MYLAR PET 138995 W270HU0	6-40-W27H1-041	
17	LCD SUPPORT SECC W270HU0	6-33-W27H1-031	
18	ANTENNA W270HU0 W/PCB 240/250/50 W/5-75MM 0710	6-23-7B710-031	FOR W270H02/HFD0
18	ANTENNA W270HU0 W/PCB 240/250/50 W/5-75MM 0710	6-23-7W27P-010	FOR W270E5Q



Appendix B: Schematic Diagrams

This appendix has circuit diagrams of the *W270HSQ* notebook's PCB's. The following table indicates where to find the appropriate schematic diagram.

Diagram - Page	Diagram - Page	Diagram - Page
<i>System Block Diagram - Page B - 2</i>	<i>PCH 1/9- RTC, HDA, SATA - Page B - 19</i>	<i>5VS, 3VS, 1.5VS CPU - Page B - 36</i>
<i>Processor 1/7-DMI, FDI, PEG - Page B - 3</i>	<i>PCH 2/9- PCIE, SMBUS, CLK - Page B - 20</i>	<i>VDD3, VDD5 - Page B - 37</i>
<i>Processor 2/7- CLK, MISC - Page B - 4</i>	<i>PCH 3/9- DMI, FDI, PWRGD - Page B - 21</i>	<i>Power 0.85VS, 1.8VS - Page B - 38</i>
<i>Processor 3/7- (DDR3) - Page B - 5</i>	<i>PCH 4/9- LVDS, DDI, CRT - Page B - 22</i>	<i>POWER 1.5V/1.05VS - Page B - 39</i>
<i>Processor 4/7- Power - Page B - 6</i>	<i>PCH 4/9- PCI, USB, RSVD - Page B - 23</i>	<i>POWER 1.05V/1.05VS VTT - Page B - 40</i>
<i>Processor 5/7- GFX PWR - Page B - 7</i>	<i>PCH 6/9- GPIO, CPU - Page B - 24</i>	<i>POWER VCORE1 - Page B - 41</i>
<i>Processor 6/7- GND - Page B - 8</i>	<i>PCH 7/9- PWR - Page B - 25</i>	<i>POWER VCORE2 - Page B - 42</i>
<i>Processor 7/7- RSVD - Page B - 9</i>	<i>PCH 8/9 POWER - Page B - 26</i>	<i>Power VGA NVVDD/PEX_VDD - Page B - 43</i>
<i>DDR3 SO-DIMM_0 - Page B - 10</i>	<i>PCH 9/9- GND - Page B - 27</i>	<i>AC IN, CHARGER - Page B - 44</i>
<i>DDR3 SO-DIMM_1 - Page B - 11</i>	<i>WLAN, 3G, MINI PCIE - Page B - 28</i>	<i>AUDIO BOARD - Page B - 45</i>
<i>PANEL, INVERTER, CRT - Page B - 12</i>	<i>CCD, TPM, MULTI CON - Page B - 29</i>	<i>CLICK BOARD - Page B - 46</i>
<i>VGA PCI-E Interface - Page B - 13</i>	<i>USB3.0 - Page B - 30</i>	<i>W251HPQ POWER SW BOARD - Page B - 47</i>
<i>VGA Frame Buffer Interface - Page B - 14</i>	<i>Card Reader (RTL8411) - Page B - 31</i>	<i>W270HU BRIDGE ODD BOARD - Page B - 48</i>
<i>VGA Frame Buffer A - Page B - 15</i>	<i>SATA ODD, LED, USB CHARGE - Page B - 32</i>	<i>W270HU POWER SW BOARD - Page B - 49</i>
<i>VGA Frame Buffer C - Page B - 16</i>	<i>HDMI, RJ45 - Page B - 33</i>	<i>Power Diagram - Page B - 50</i>
<i>VGA I/O - Page B - 17</i>	<i>AUDIO CODEC VT1802P - Page B - 34</i>	<i>Power On SEQ - Page B - 51</i>
<i>VGA NVVDD Cecoupling - Page B - 18</i>	<i>KBC-ITE IT8518E - Page B - 35</i>	

Table B - 1
**SCHEMATIC
DIAGRAMS**



Version Note

The schematic diagrams in this chapter are based upon version 6-7P-W25S6-002. If your mainboard (or other boards) are a later version, please check with the Service Center for updated diagrams (if required).

System Block Diagram

Sheet 1 of 50
System Block
Diagram

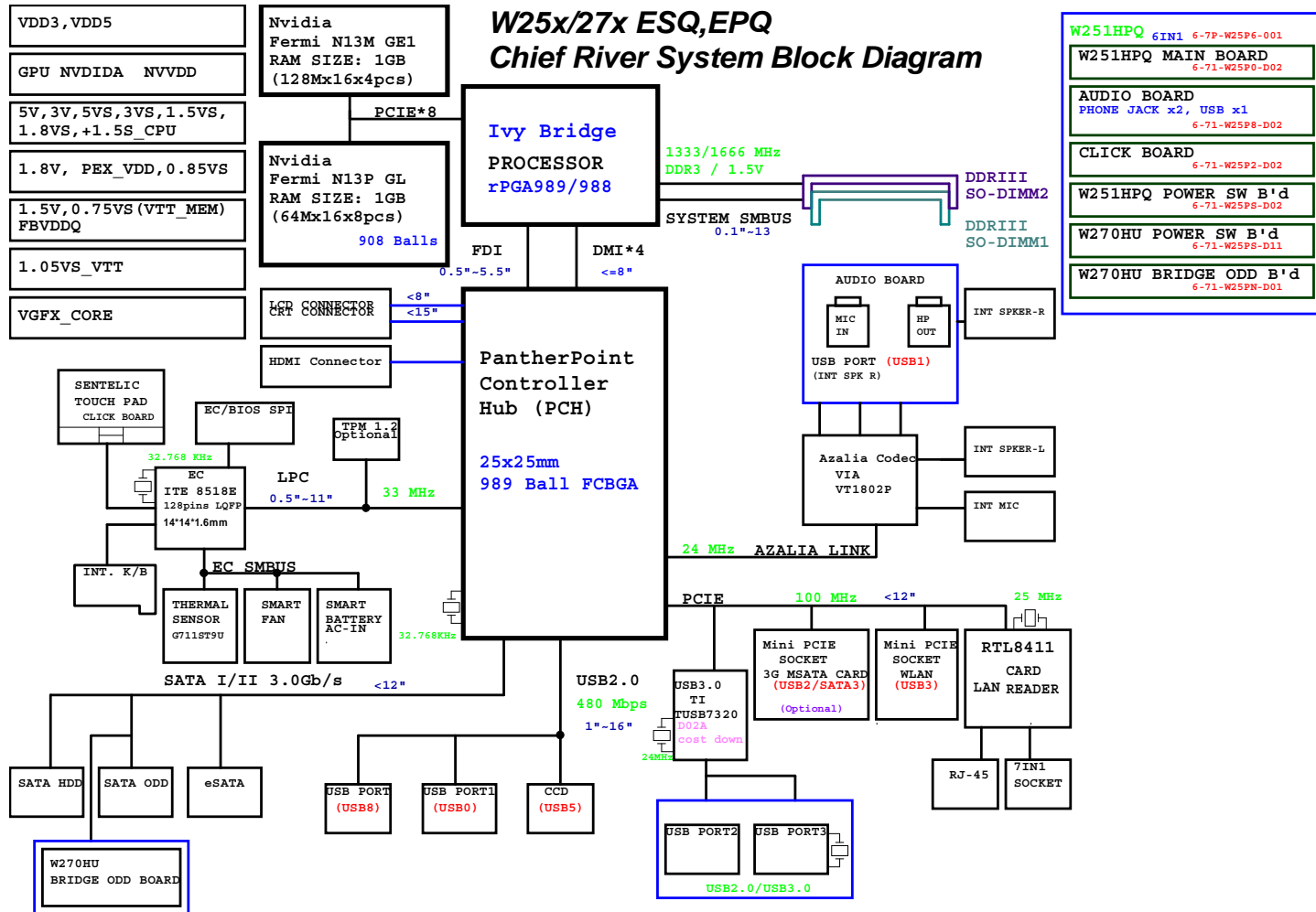

Processor 1/7-DMI, FDI, PEG

Ivy Bridge Processor 1/7 (DMI, PEG, FDI)

- Ivy Bridge Quad Core 55W
 - Ivy Bridge Dual Core 35W
 - Ivy Bridge LV/ULV 25/17W
- 2012 Ivy Bridge Socket compatible with Sandy Bridge.
- 2012 Ivy Bridge Same TDP as Sandy Bridge.
- 2012 Ivy DDR3-1600 and DDR3L-1333 Support.
- 2012 Ivy PCIe*Gen3.0(PEGX16).
- 2012 Ivy DX11 Support, 3 Simultaneous Displays.

CAD NOTE: DP_COMPIO and ICOMPO signals should be shorted near balls and routed with - typical impedance < 25 mohms

EDP HPD Function Disable
EDP_HPDI: Pull-up10K- DISABLED HPDI

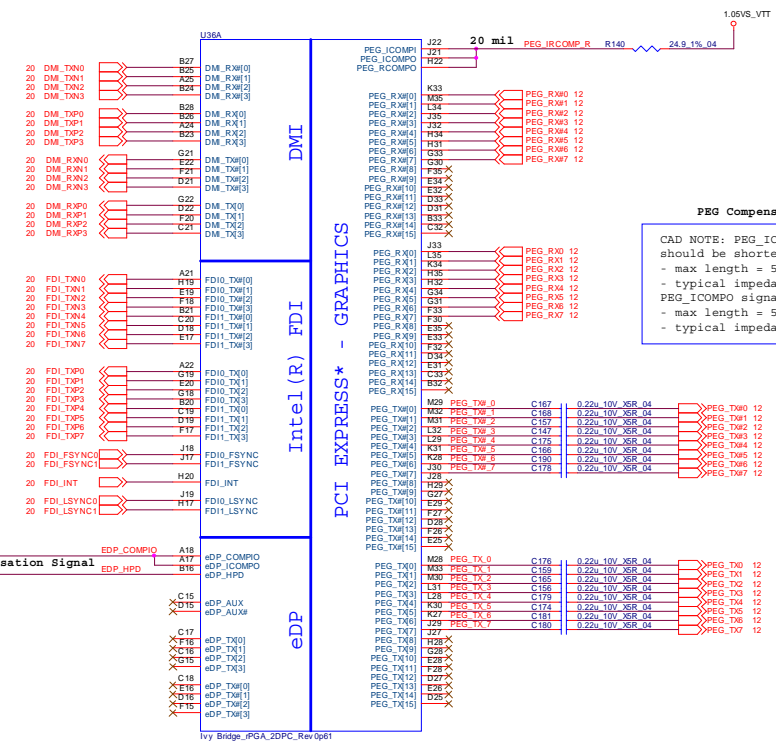
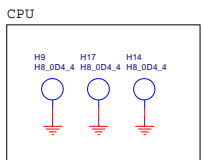

PEG Compensation Signal

CAD NOTE: PEG_ICOMPI and RCOMP signals should be shorted and routed with

- max length = 500 mils
- typical impedance = 43 mohms

PEG_ICOMPO signals should be routed with

- max length = 500 mils
- typical impedance = 14.5 mohms

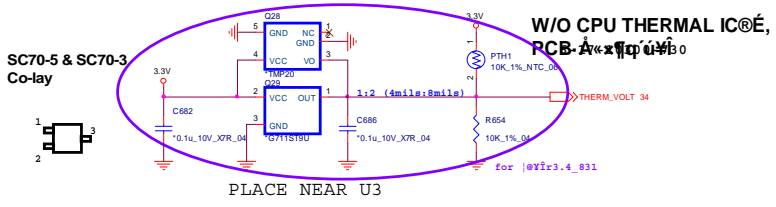

Sheet 2 of 50
Processor 1/7-DMI,
FDI, PEG

B.Schematic Diagrams

Processor 2/7- CLK, MISC

Sheet 3 of 50
Processor 2/7-CLK,
MISC

Ivy Bridge Processor 2/7 (CLK,MISC,JTAG)

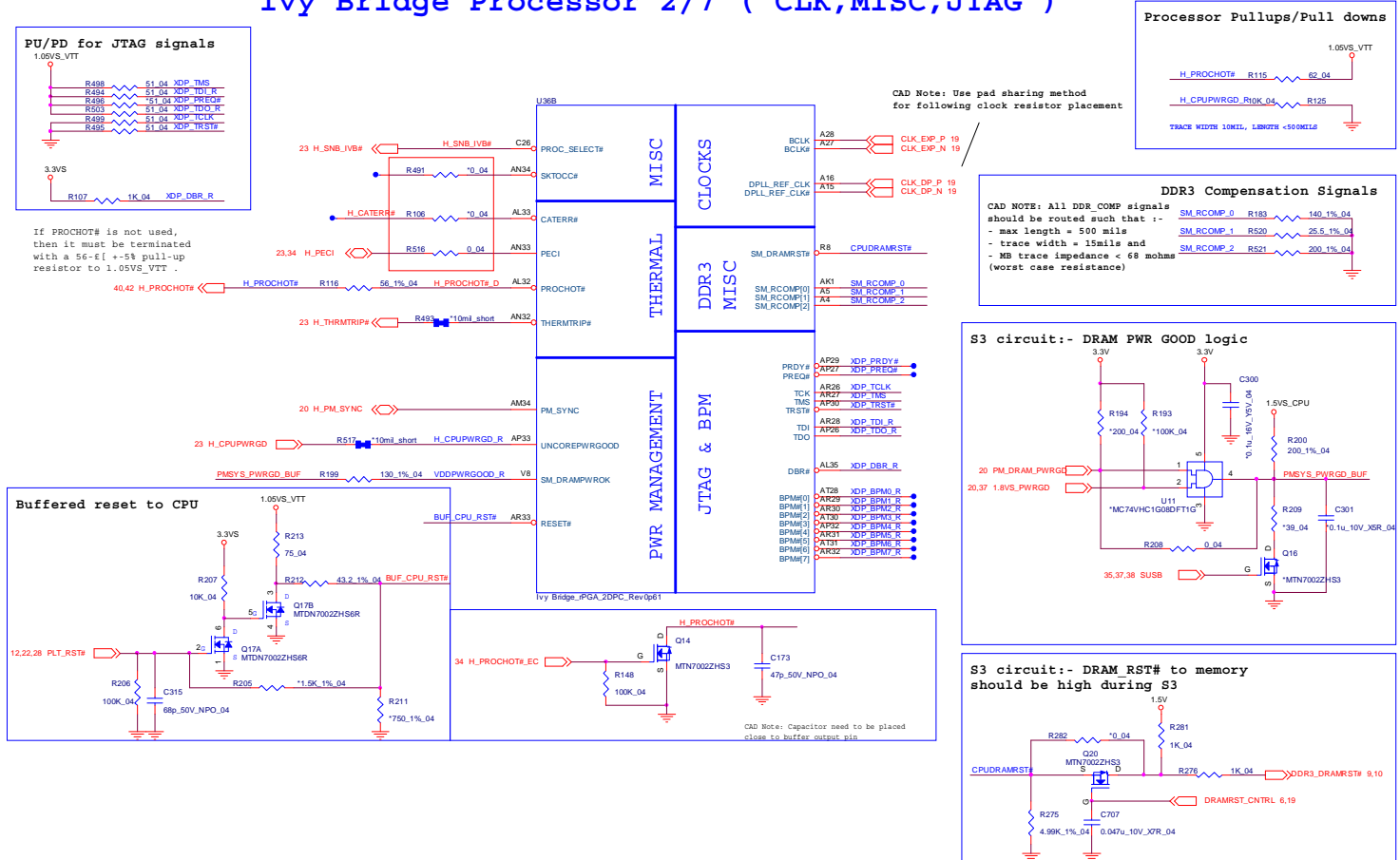

Processor 3/7- (DDR3)

Ivy Bridge Processor 3/7 (DDR3)

B.Schematic Diagrams

Sheet 4 of 50
Processor 3/7-
(DDR3)

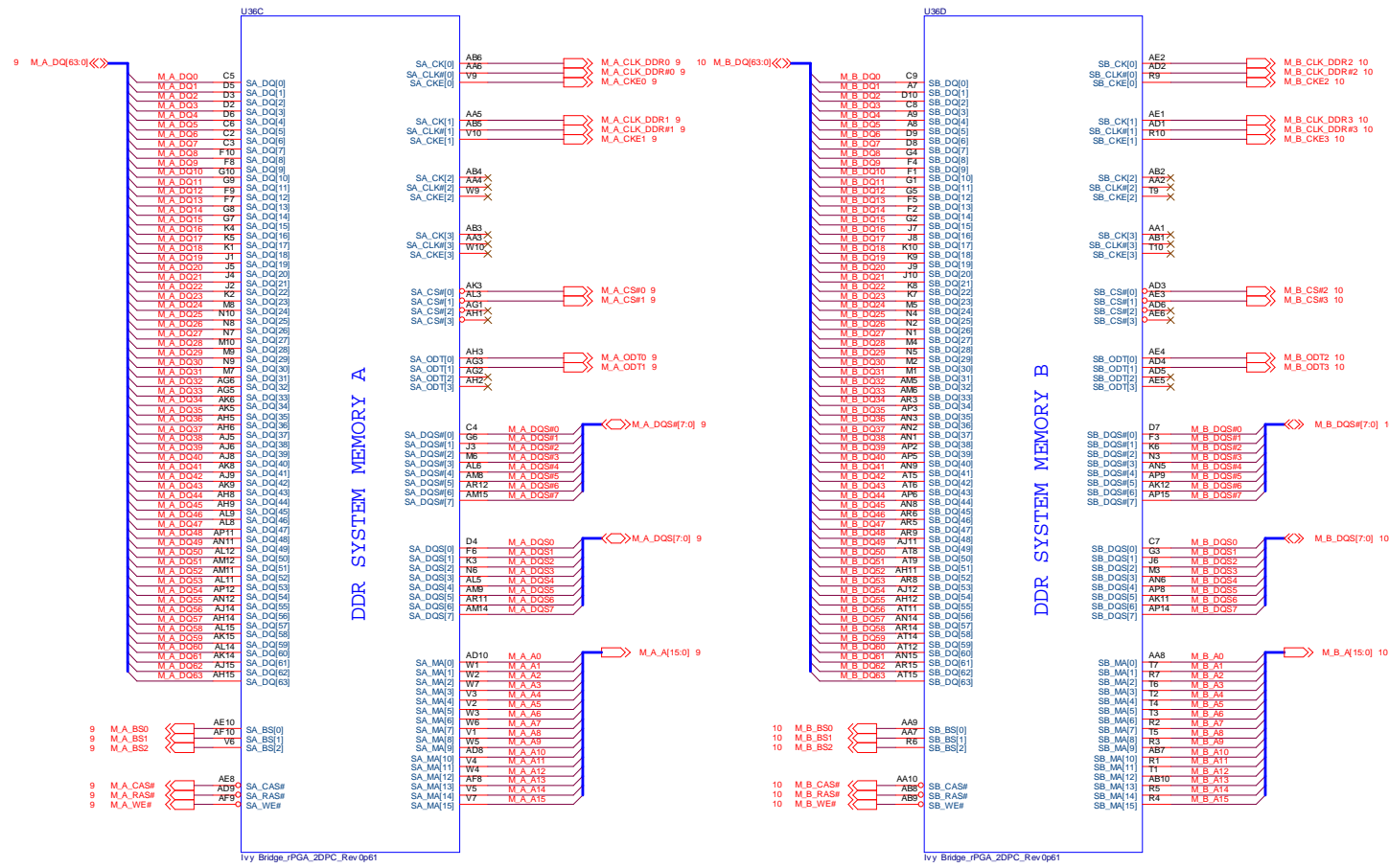

Processor 4/7- Power

Ivy Bridge Processor 4/7 (POWER)

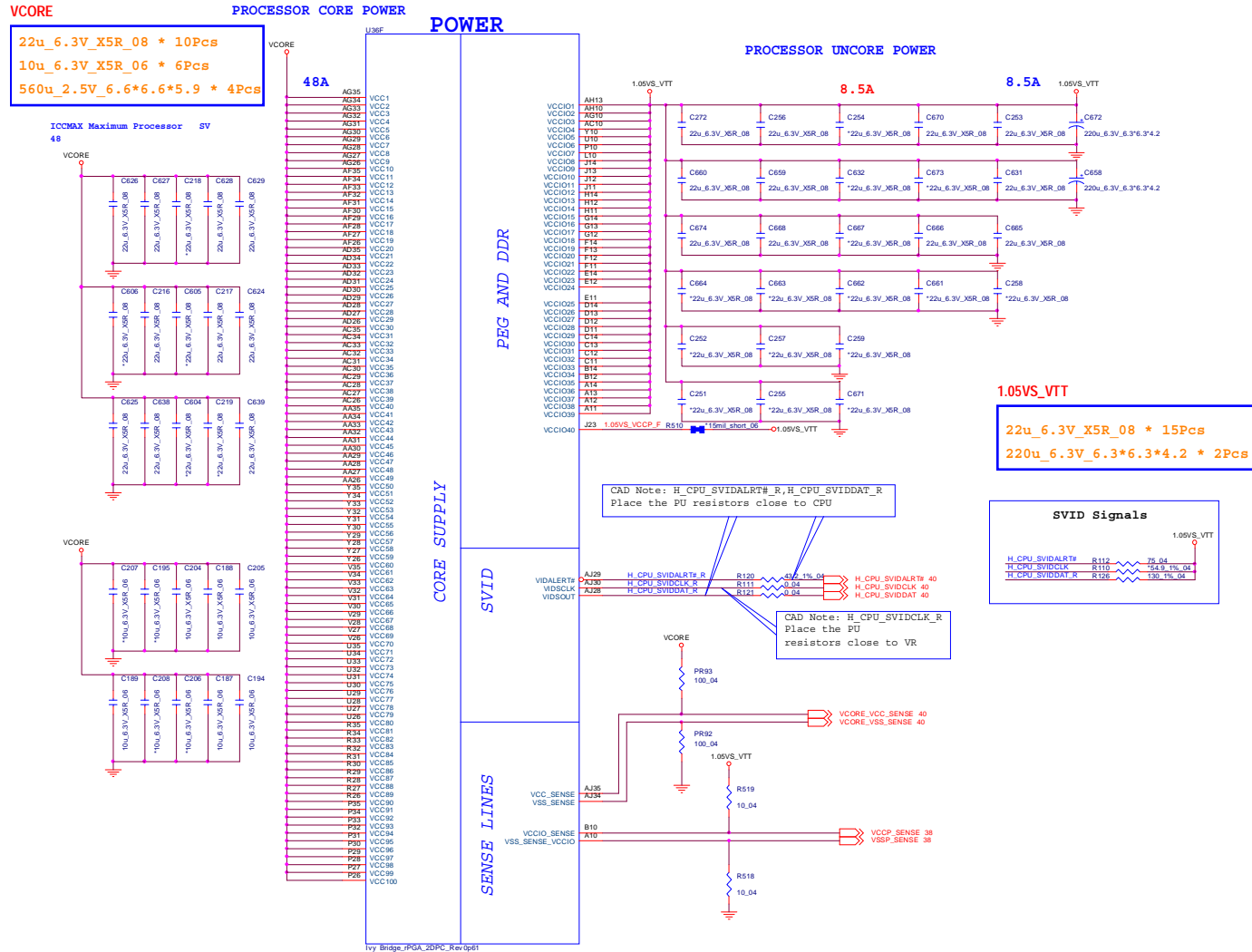

Sheet 5 of 50
Processor 4/7-
Power

B.Schematic Diagrams

Processor 5/7- GFX PWR

Ivy Bridge Processor 5/7 (GRAPHICS POWER)

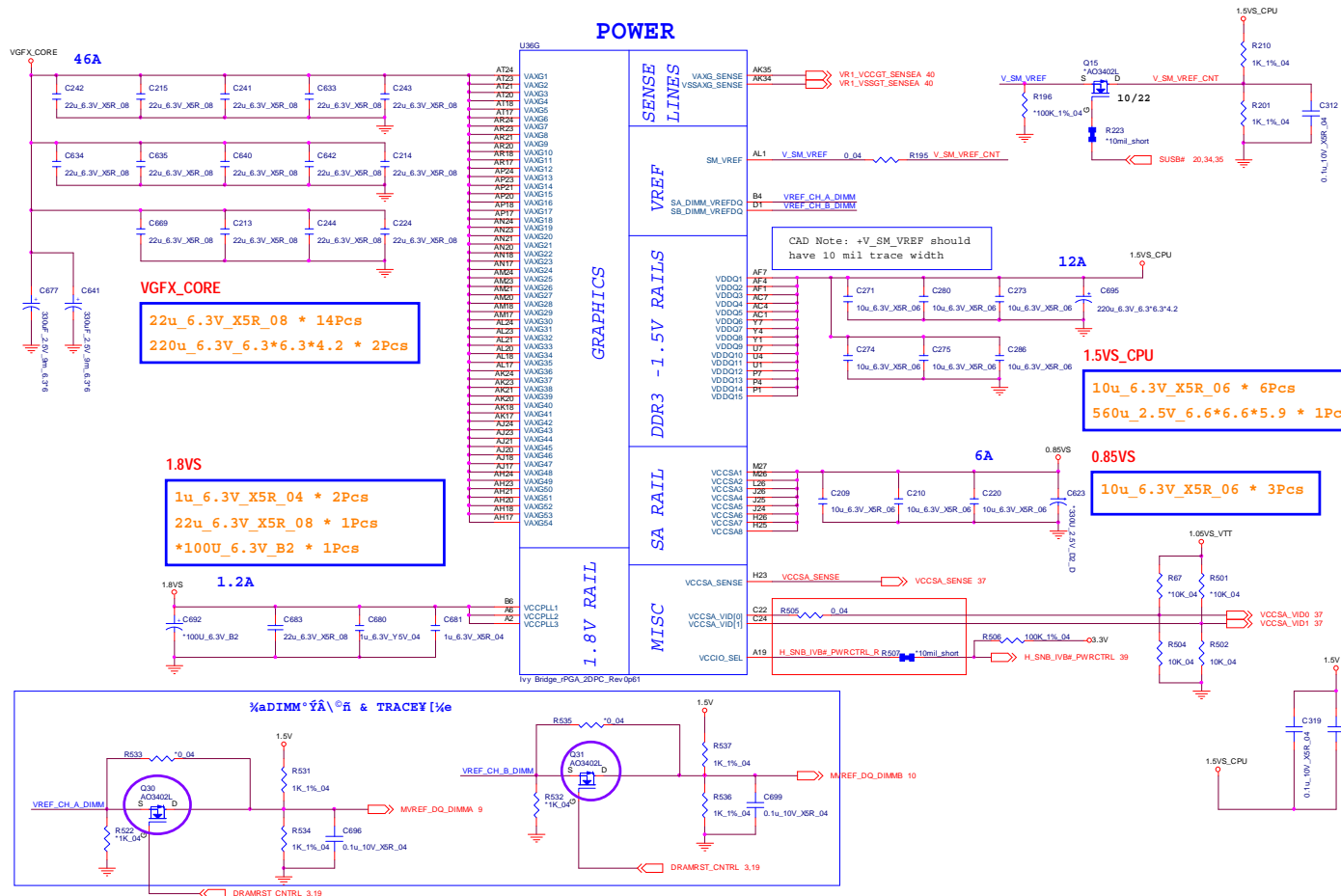

Sheet 6 of 50
Processor 5/7- GFX
PWR

B.Schematic Diagrams

Processor 6/7- GND

Ivy Bridge Processor 6/7 (GND)

CAD Note: 0 ohm resistor should be placed close to CPU

Sheet 7 of 50
Processor 6/7- GND

B.Schematic Diagrams

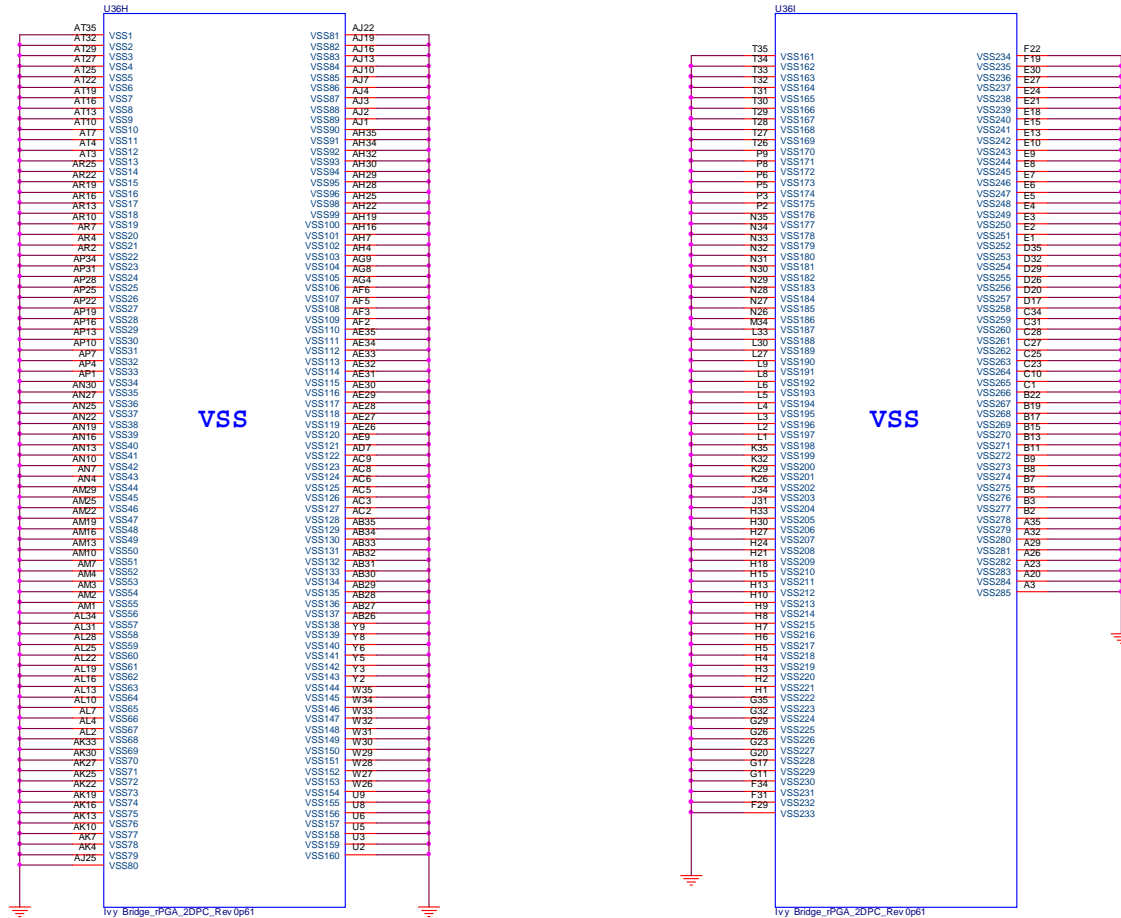

Processor 7/7- RSVD

Ivy Bridge Processor 7/7 (RESERVED)

CFG Straps for Processor

PEG Static Lane Reversal - CFG2 is for the 16x	
CFG2	1: (Default) Normal Operation; Lane # definition matches socket pin map definition 0: Lane Reversed

Display Port Presence Strap

CFG4	1: (Default) Disabled; No Physical Display Port attached to Embedded Display Port 0: Enabled; An external Display Port device is connected to the Embedded Display Port
-------------	--

PCIe Port Bifurcation Straps

CFG6 [6 : 5]	11: (Default) x16 - Device 1 functions 1 and 2 disabled 10: x8, x8 - Device 1 function 1 enabled ; function 2 disabled 01: Reserved - (Device 1 function 1 disabled ; function 2 enabled) 00: x8,x4,x4 - Device 1 functions 1 and 2 enabled
-----------------------	--

On CRB
H_SNB_IVB#_PWRCTRL = low, 1.0V
H_SNB_IVB#_PWRCTRL = high/NC, 1.05V

PEG DEPER TRAINING

CFG7	1: (Default) PEG Train immediately following xxRESETB de assertion 0: PEG Wait for BIOS for training
-------------	---

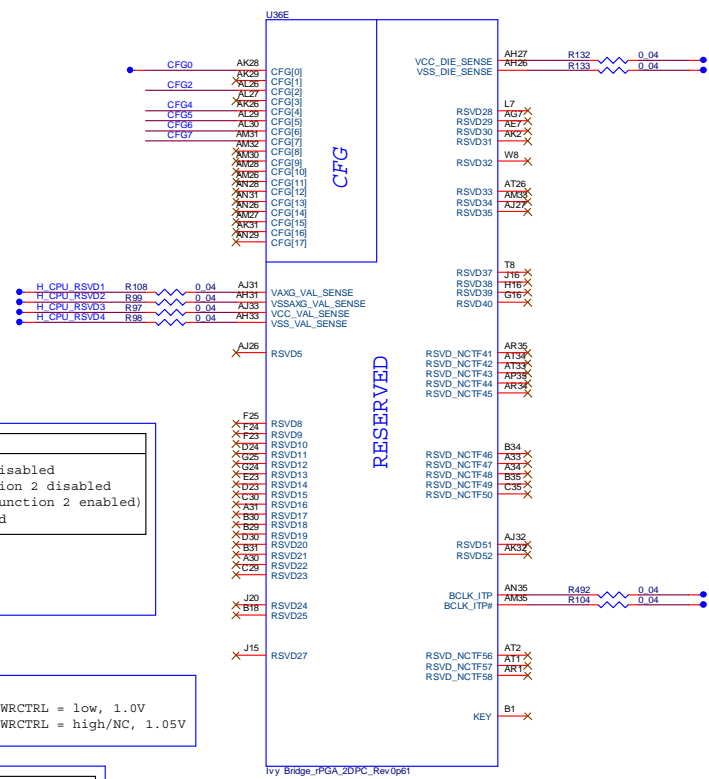

Sheet 8 of 50
Processor 7/7-
RSVD

B.Schematic Diagrams

DDR3 SO-DIMM_0

SO-DIMM A

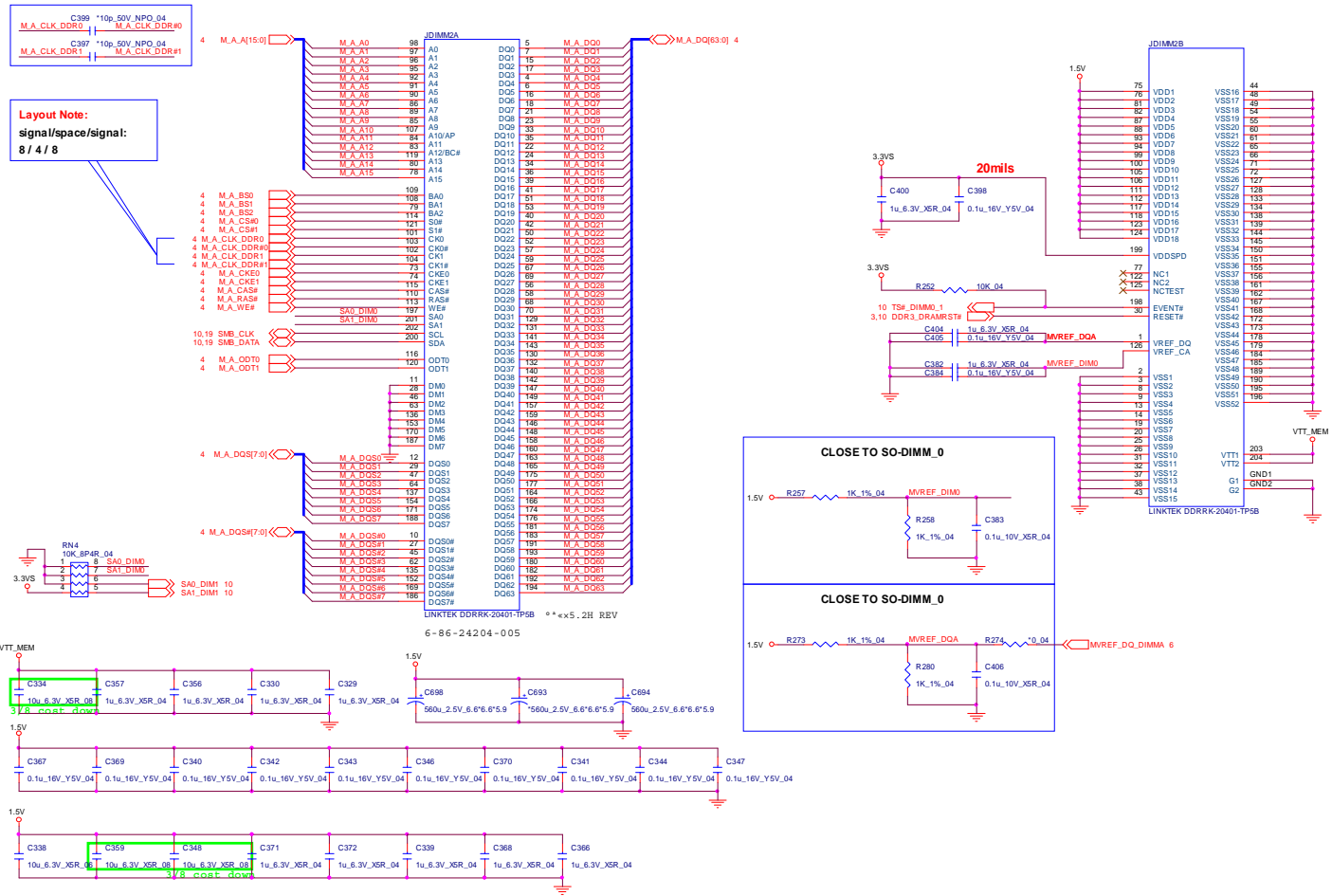

DDR3 SO-DIMM_1

SO-DIMM B

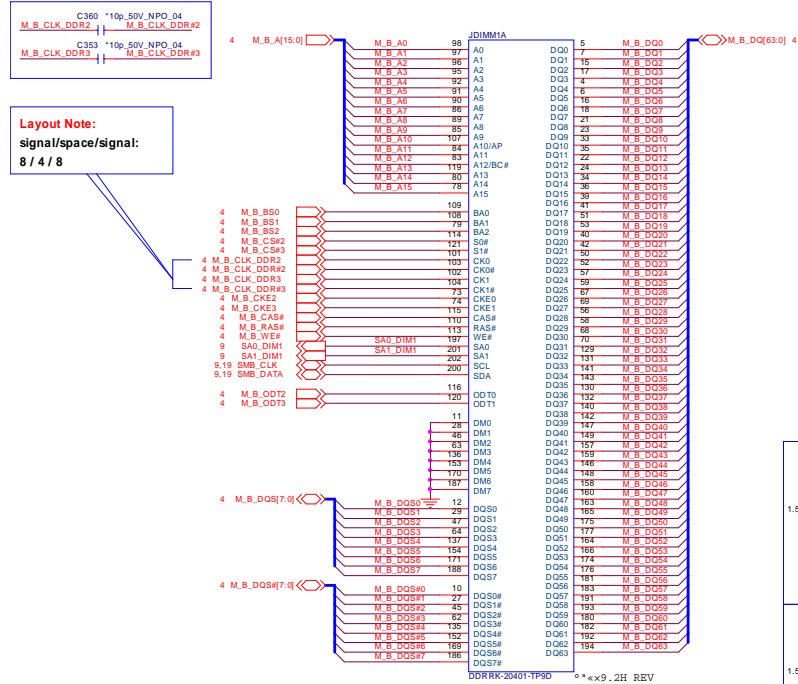

Layout Note:
signal/space/signal:
8 / 4 / 8

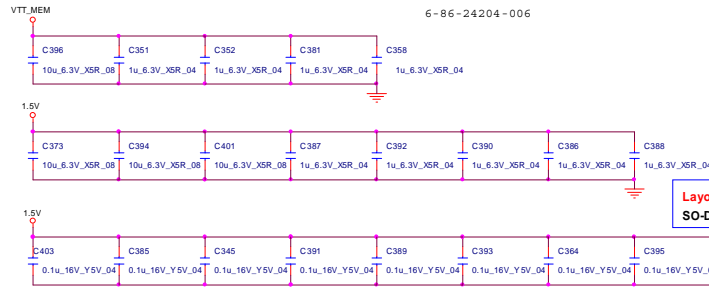
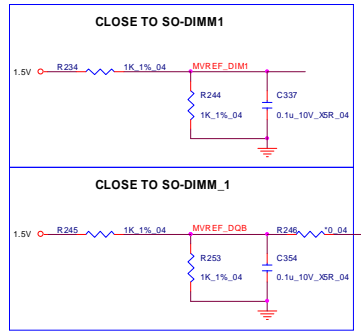
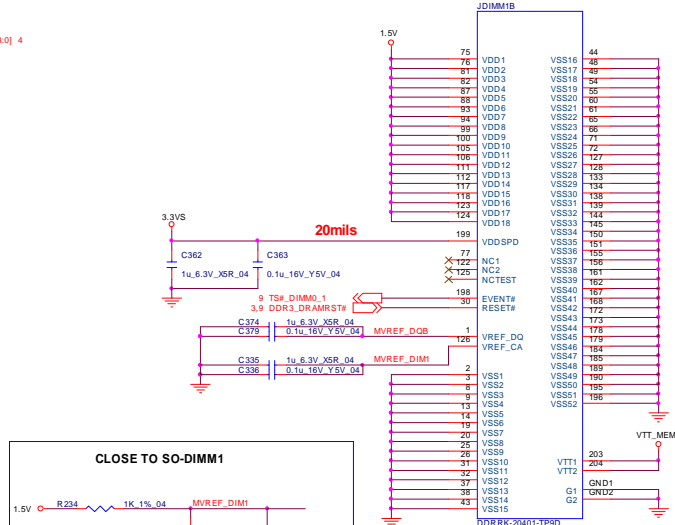

Layout Note:
SO-DIMM_1 is placed farther from the GMCH than SO-DIMM_0

Sheet 10 of 50
DDR3 SO-DIMM_1

PANEL, INVERTER, CRT

PANEL CONNECTOR (30Pin & 40Pin CO-lay)

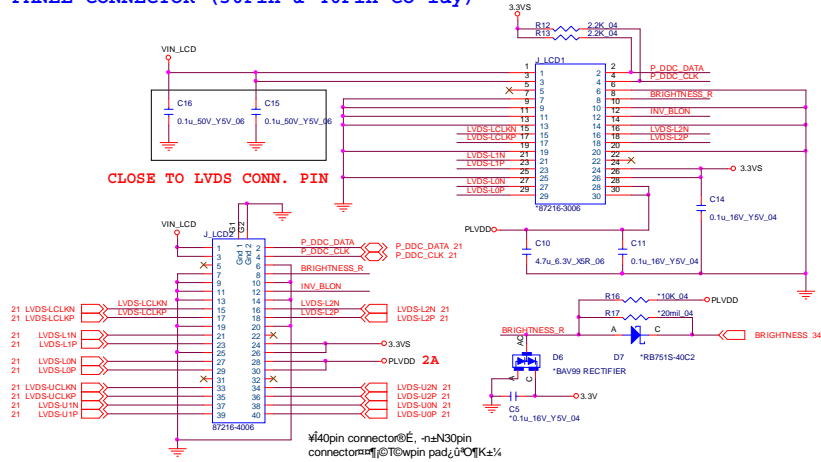

CRT

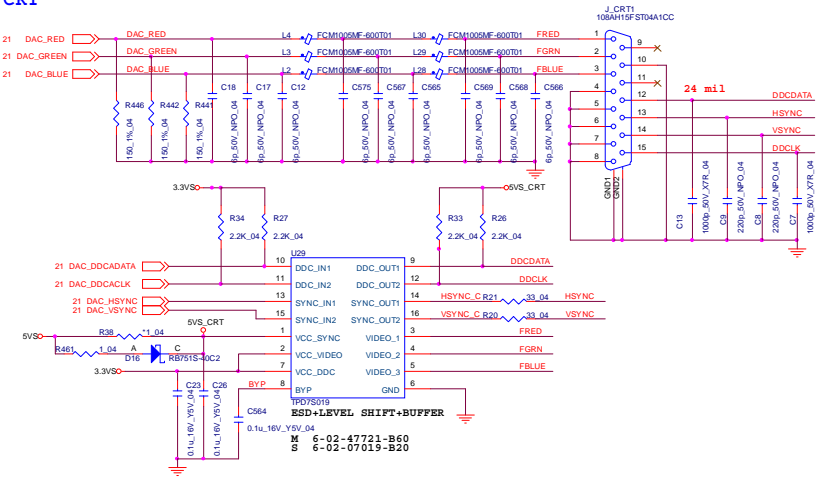

PANEL POWER

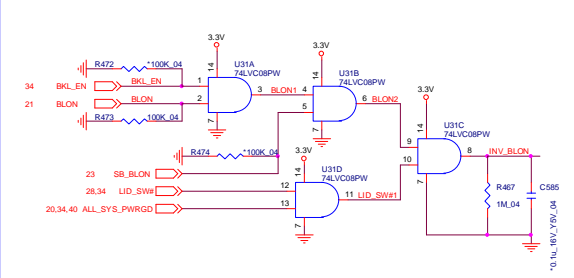
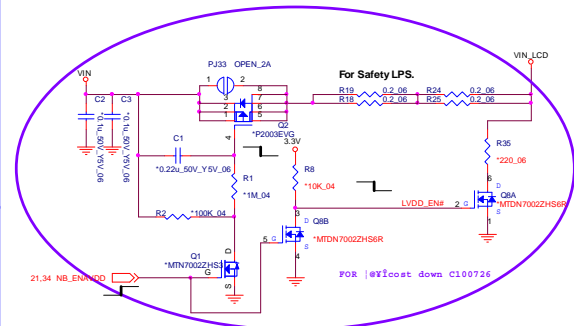
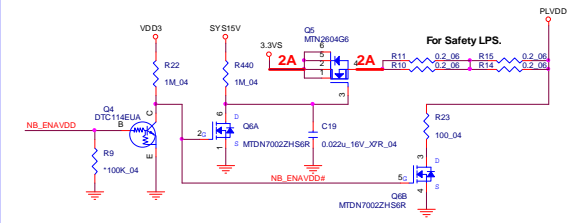

B.Schematic Diagrams

Sheet 11 of 50
PANEL, INVERTER,
CRT

VGA PCI-E Interface

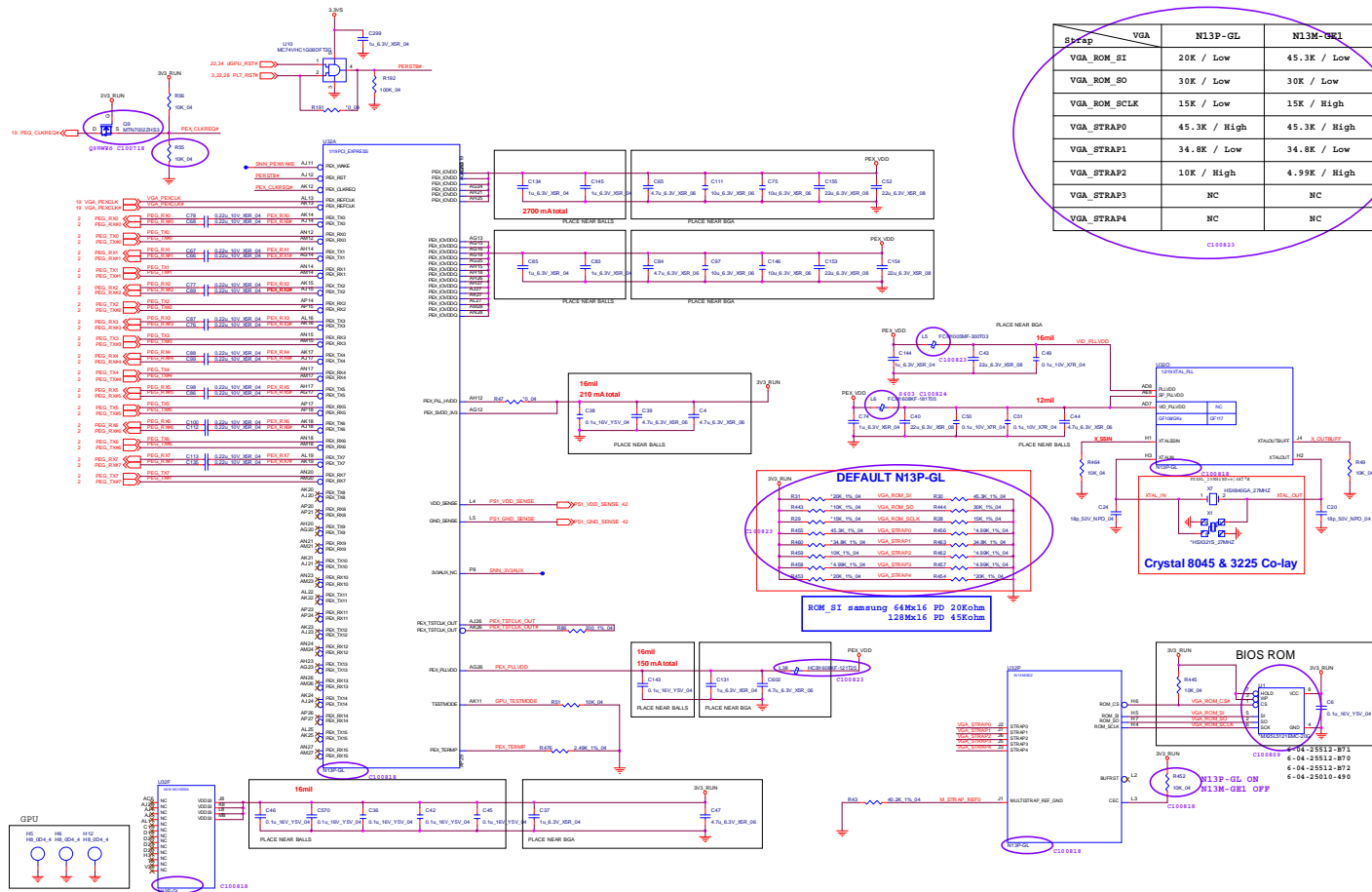

Signal	VGA	N13P-GL	N13M-GB1
VGA_ROM_SI	20K / Low	45.3K / Low	
VGA_ROM_SO	30K / Low	30K / Low	
VGA_ROM_SCLK	15K / Low	15K / High	
VGA_STRAP0	45.3K / High	45.3K / High	
VGA_STRAP1	34.8K / Low	34.8K / Low	
VGA_STRAP2	10K / High	4.99K / High	
VGA_STRAP3	NC	NC	
VGA_STRAP4	NC	NC	

Sheet 12 of 50
VGA PCI-E
Interface

B.Schematic Diagrams

VGA Frame Buffer A

Frame Buffer Partition A

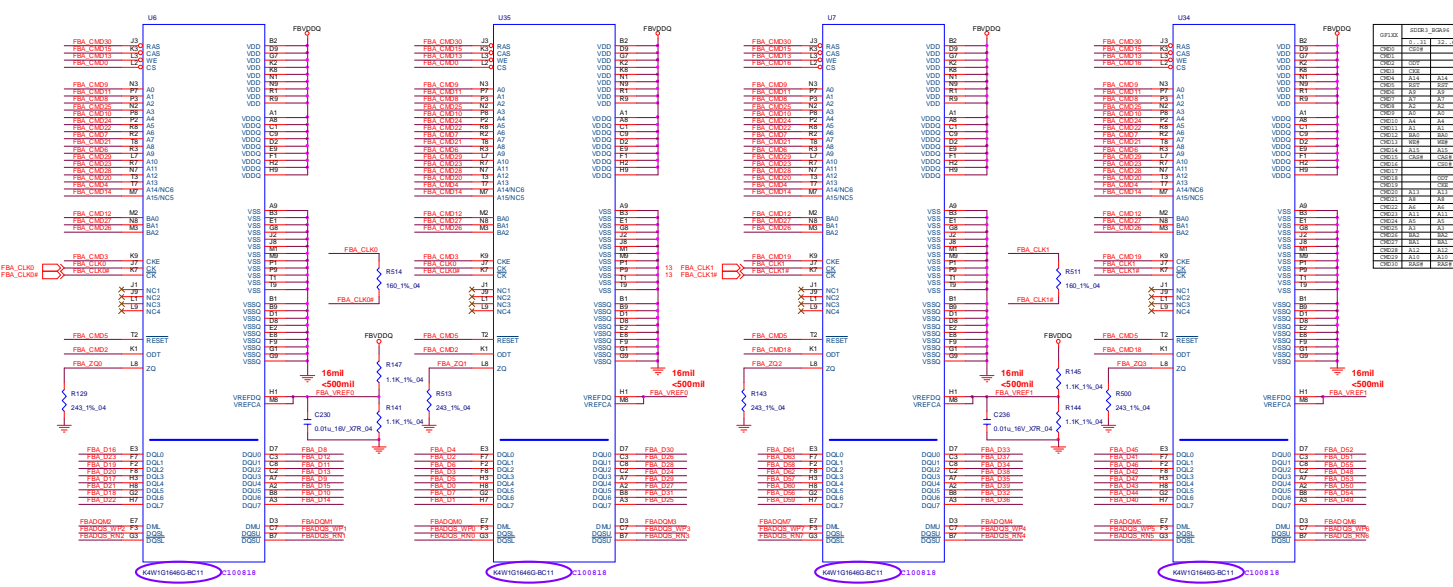
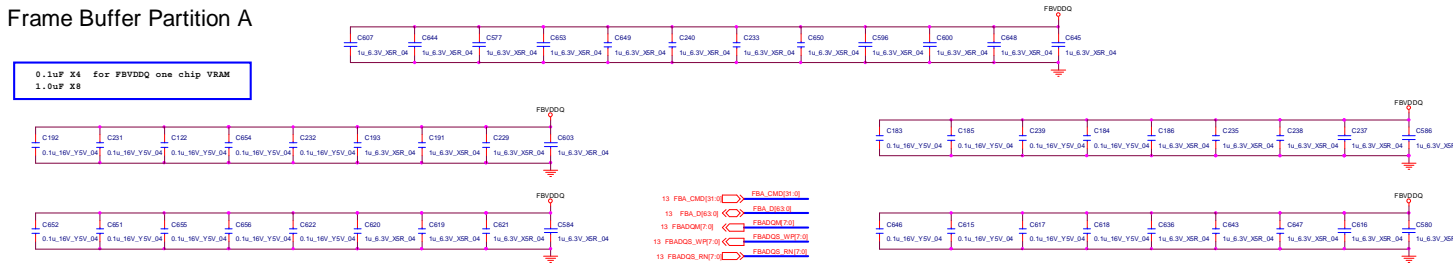

Sheet 14 of 50
VGA Frame Buffer
A

B.Schematic Diagrams

VGA Frame Buffer C

Frame Buffer Partition B

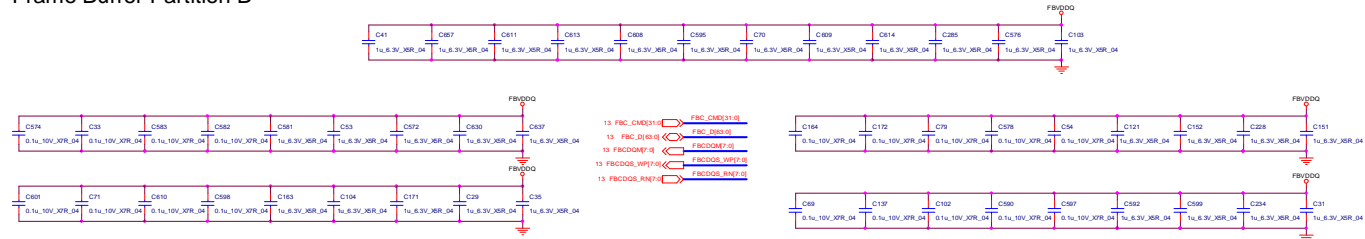

Sheet 15 of 50
VGA Frame Buffer
C

B.Schematic Diagrams

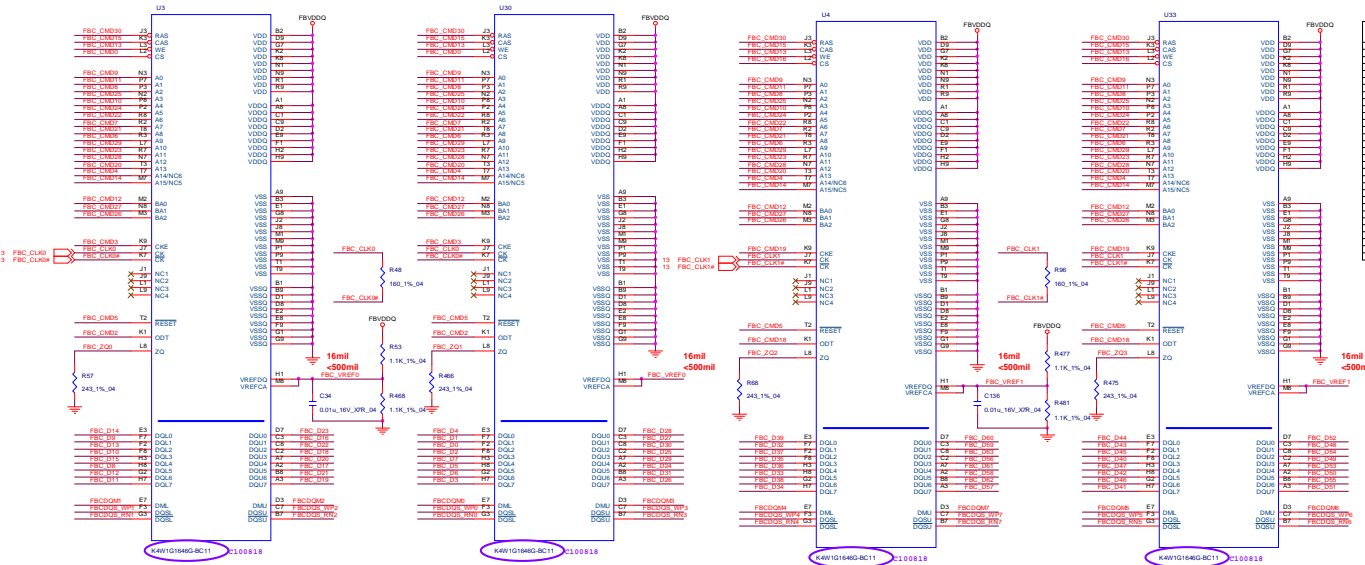

VGA I/O

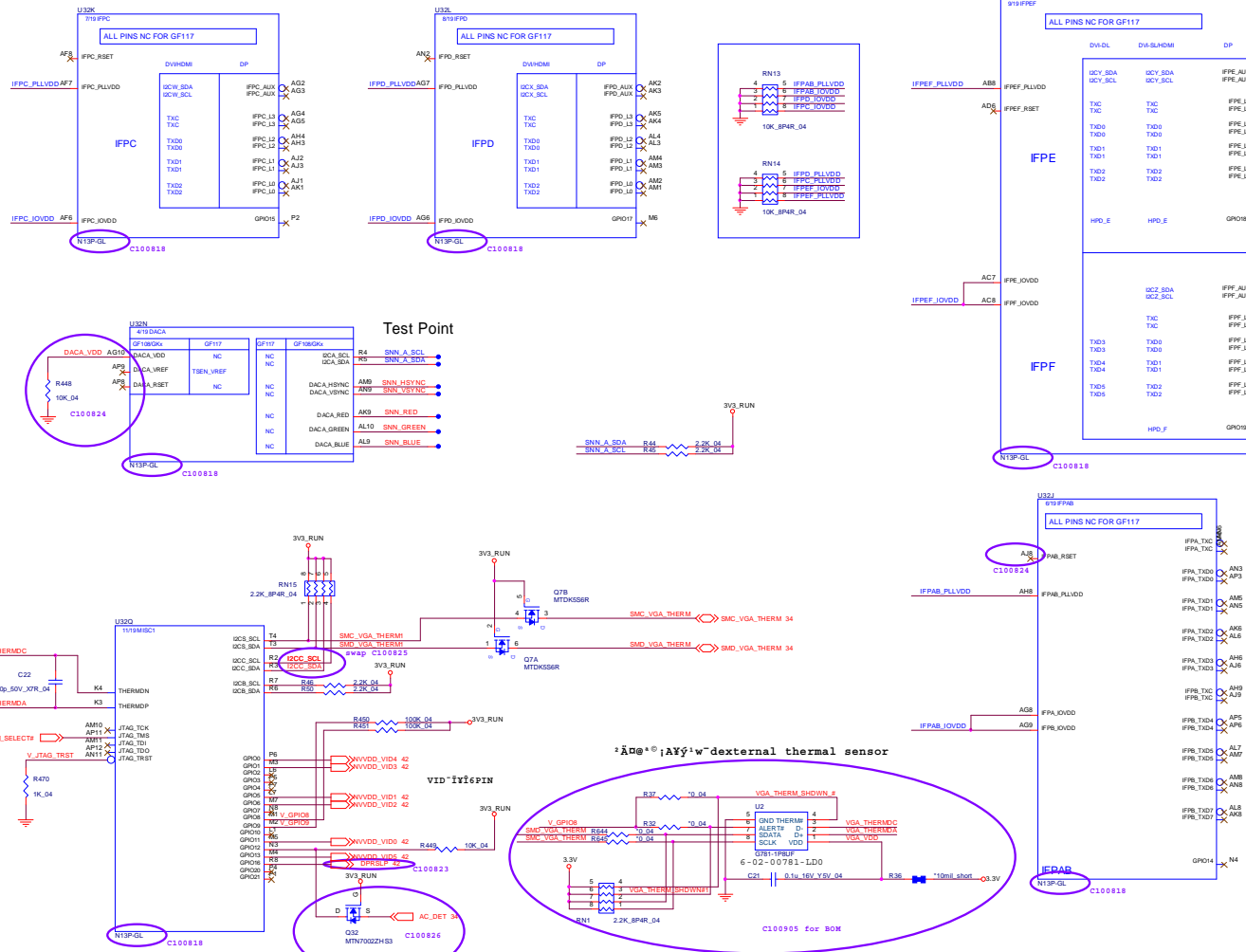

Sheet 16 of 50
VGA I/O

VGA NVVDD Cecoupling

Sheet 17 of 50
VGA NVVDD
Cecoupling

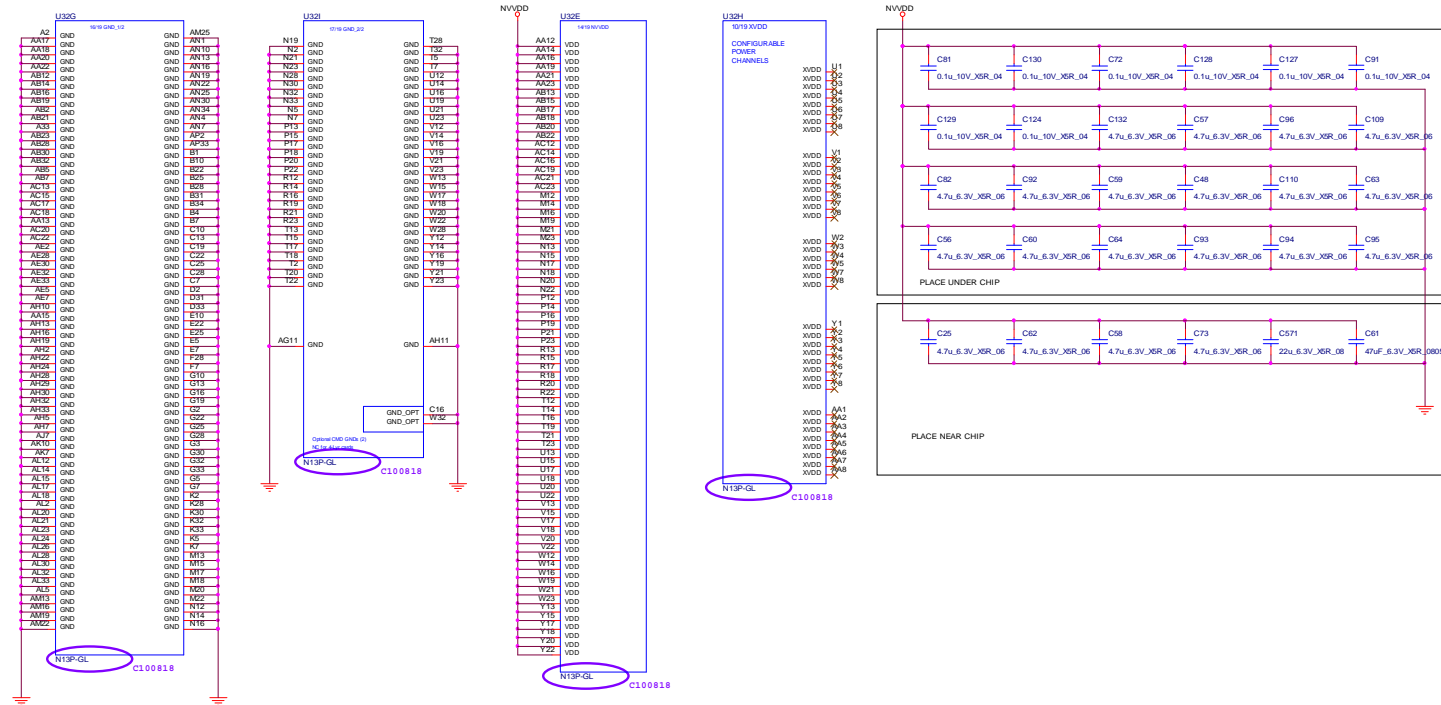

PCH 1/9- RTC, HDA, SATA

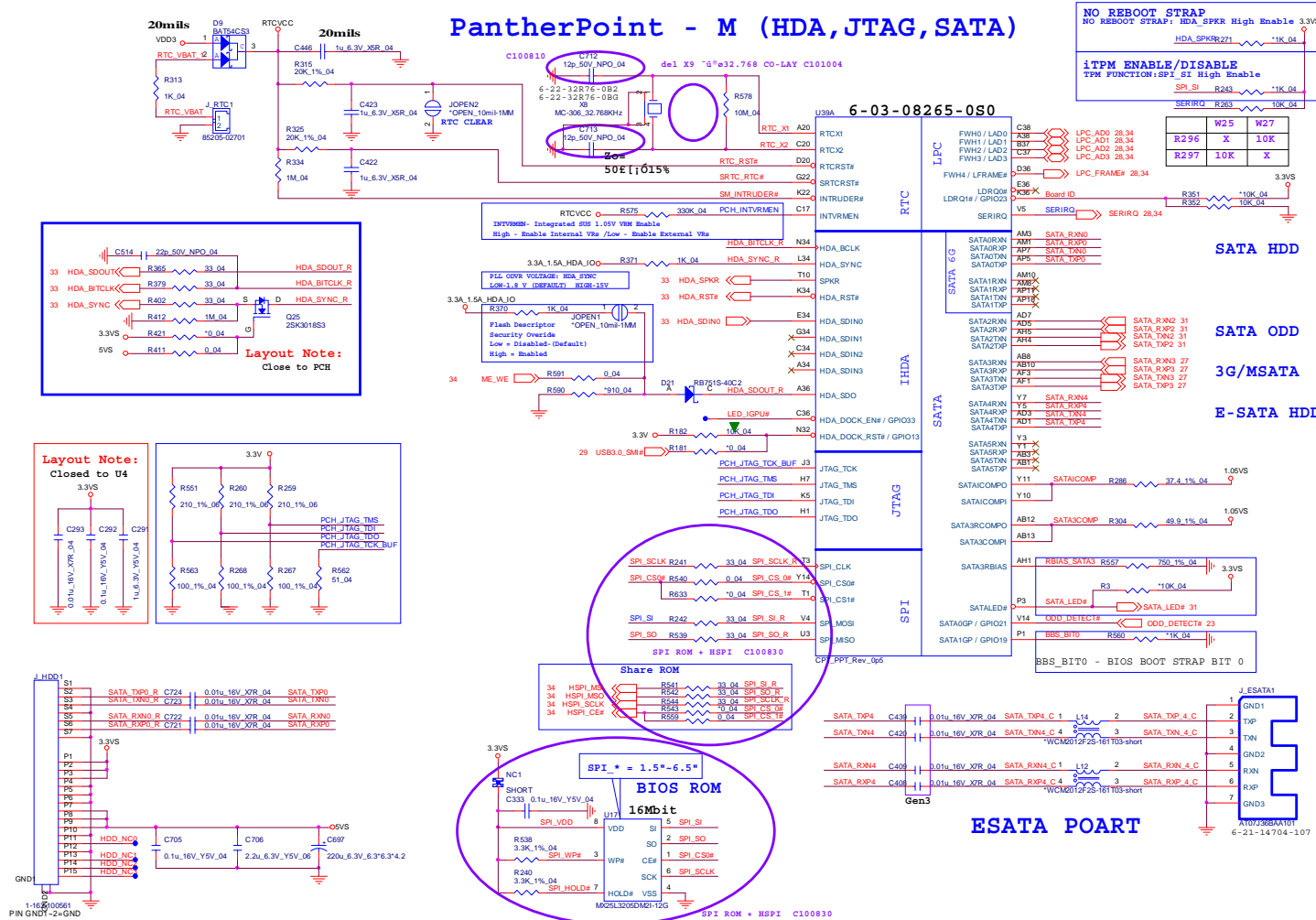

B.Schematic Diagrams

Sheet 18 of 50
PCH 1/9- RTC, HDA,
SATA

PCH 2/9- PCIE, SMBUS, CLK

Sheet 19 of 50
PCH 2/9- PCIE,
SMBUS, CLK

PCI-E x1	Usage
Lane 1	X
Lane 2	TI USB 3.0
Lane 3	WLAN
Lane 4	GLAN / CARD READER
Lane 5	X
Lane 6	X
Lane 7	X
Lane 8	X

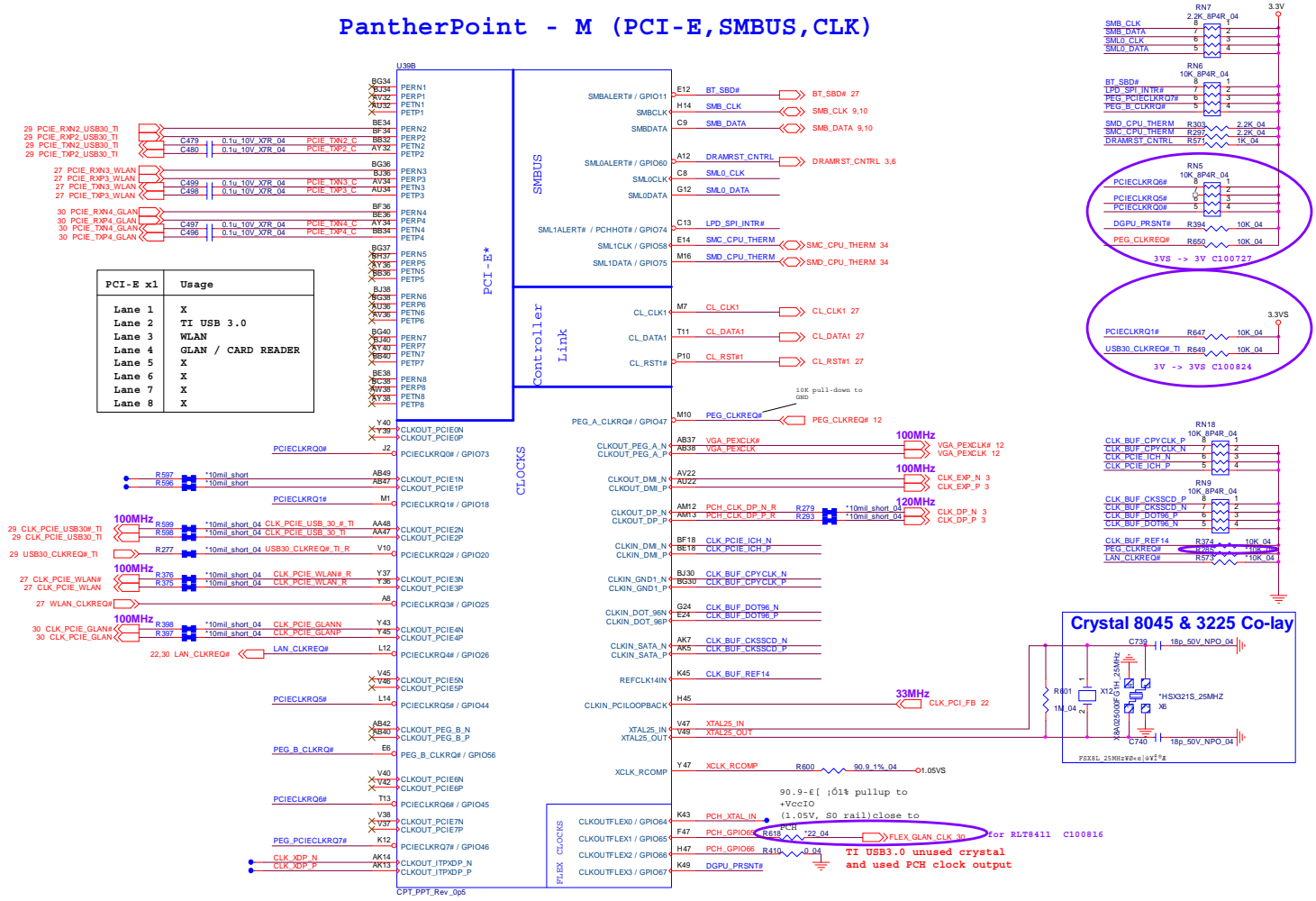

PCH 3/9- DMI, FDI, PWRGD

PantherPoint -M (DMI, FDI, GPIO)

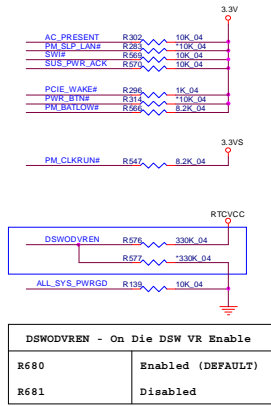
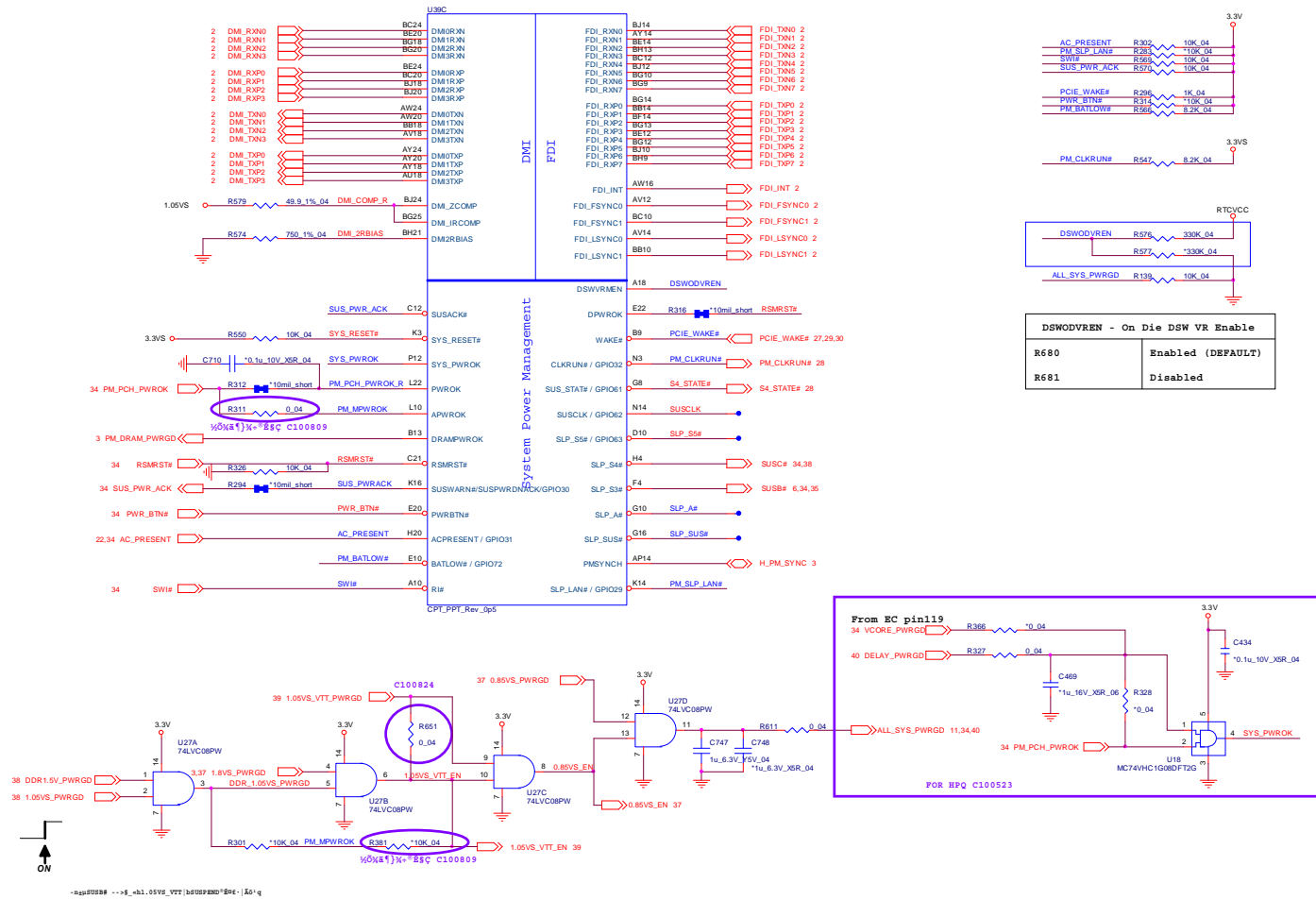

DSWDVREN - On Die DSW VR Enable	
R680	Enabled (DEFAULT)
R681	Disabled

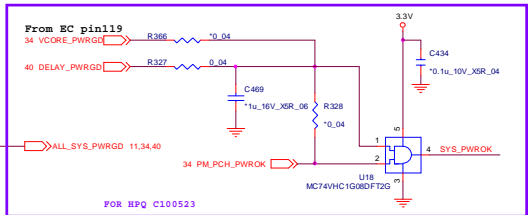

Sheet 20 of 50
PCH 3/9- DMI, FDI,
PWRGD

B.Schematic Diagrams

PCH 4/9- LVDS, DDI, CRT

B.Schematic Diagrams

Sheet 21 of 50
PCH 4/9- LVDS,
DDI, CRT

PantherPoint -M (LVDS,DDI)

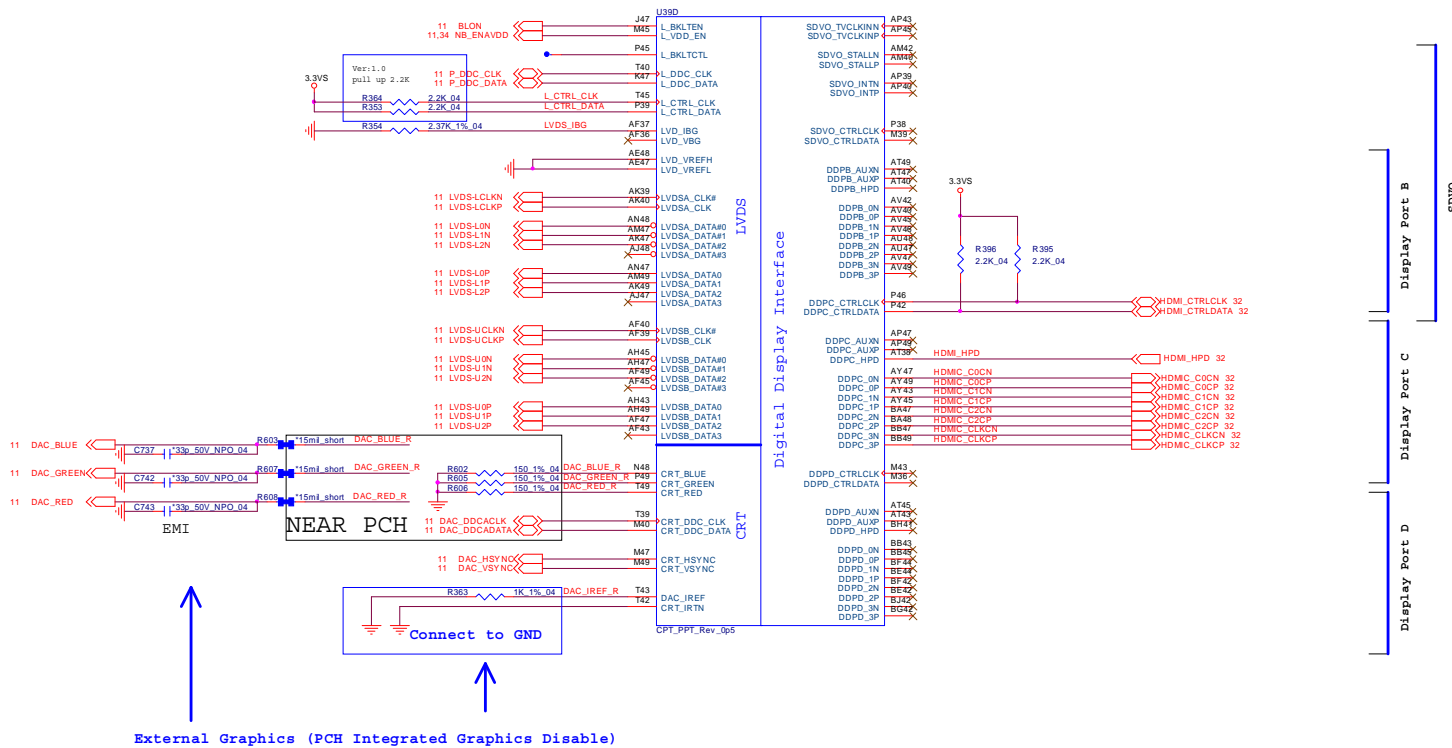

PCH 4/9- PCI, USB, RSVD

PantherPoint -M (PCI,USB,NVRAM)

Boot BIOS Strap		
BBS_BIT1	BBS_BIT0	Boot BIOS Location
0	0	LPC
0	1	Reserved (NAND)
1	0	PCI
1	1	SPI



Flash Descriptor security override strap	
PCI_GNT#3	LOW = PCI_GNT#3 swap override HIGH = Default

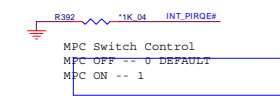
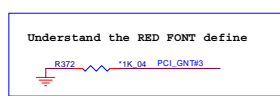

MPC Switch Control
MPC OFF -- 0 DEFAULT
MPC ON -- 1

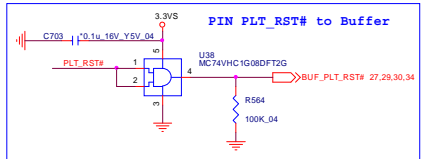
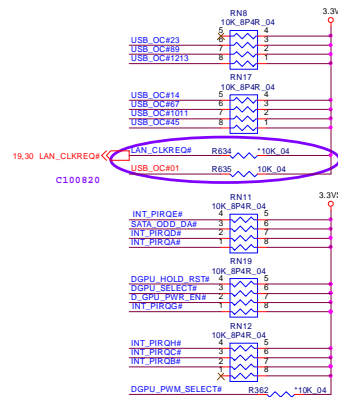
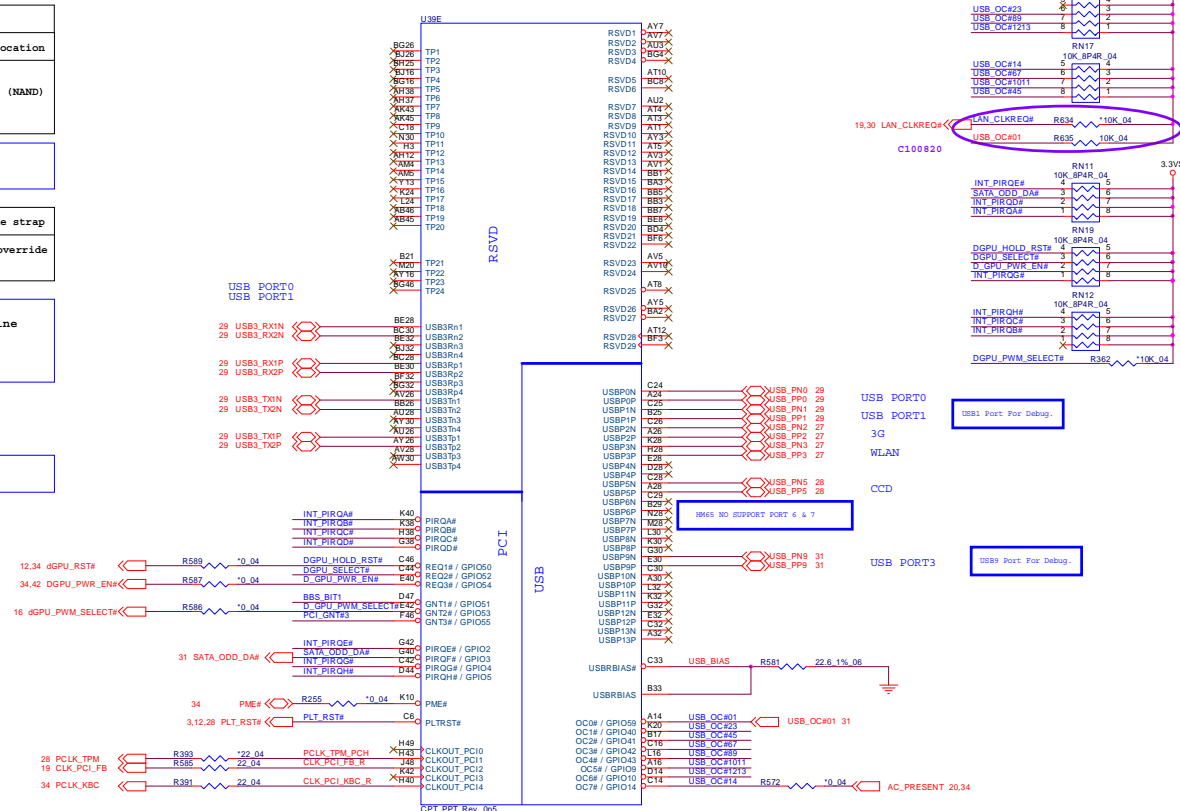

Sheet 22 of 50
PCH 4/9- PCI, USB,
RSVD

PCH 6/9- GPIO, CPU

Sheet 23 of 50
PCH 6/9- GPIO,
CPU

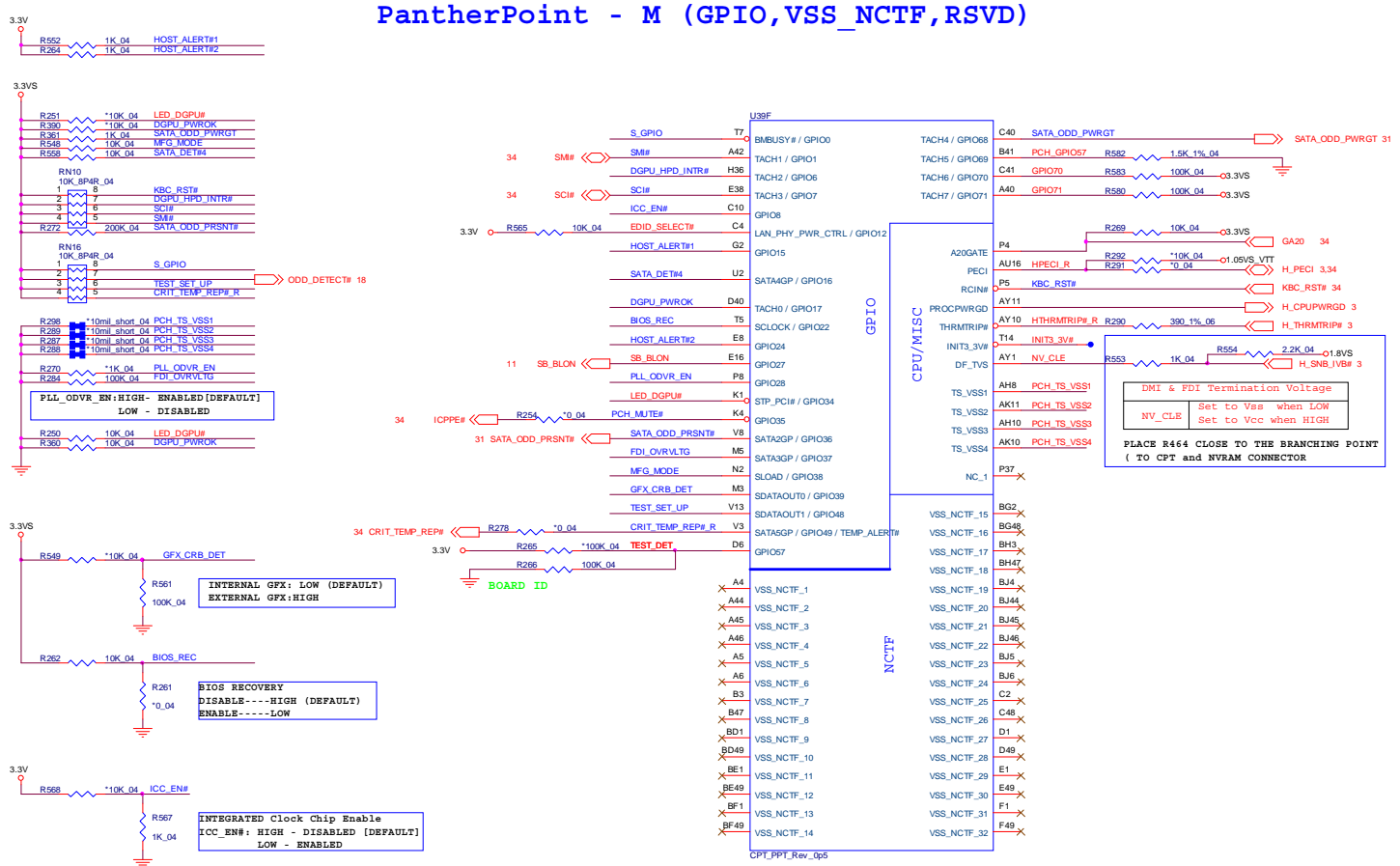

PCH 7/9- PWR

B.Schematic Diagrams

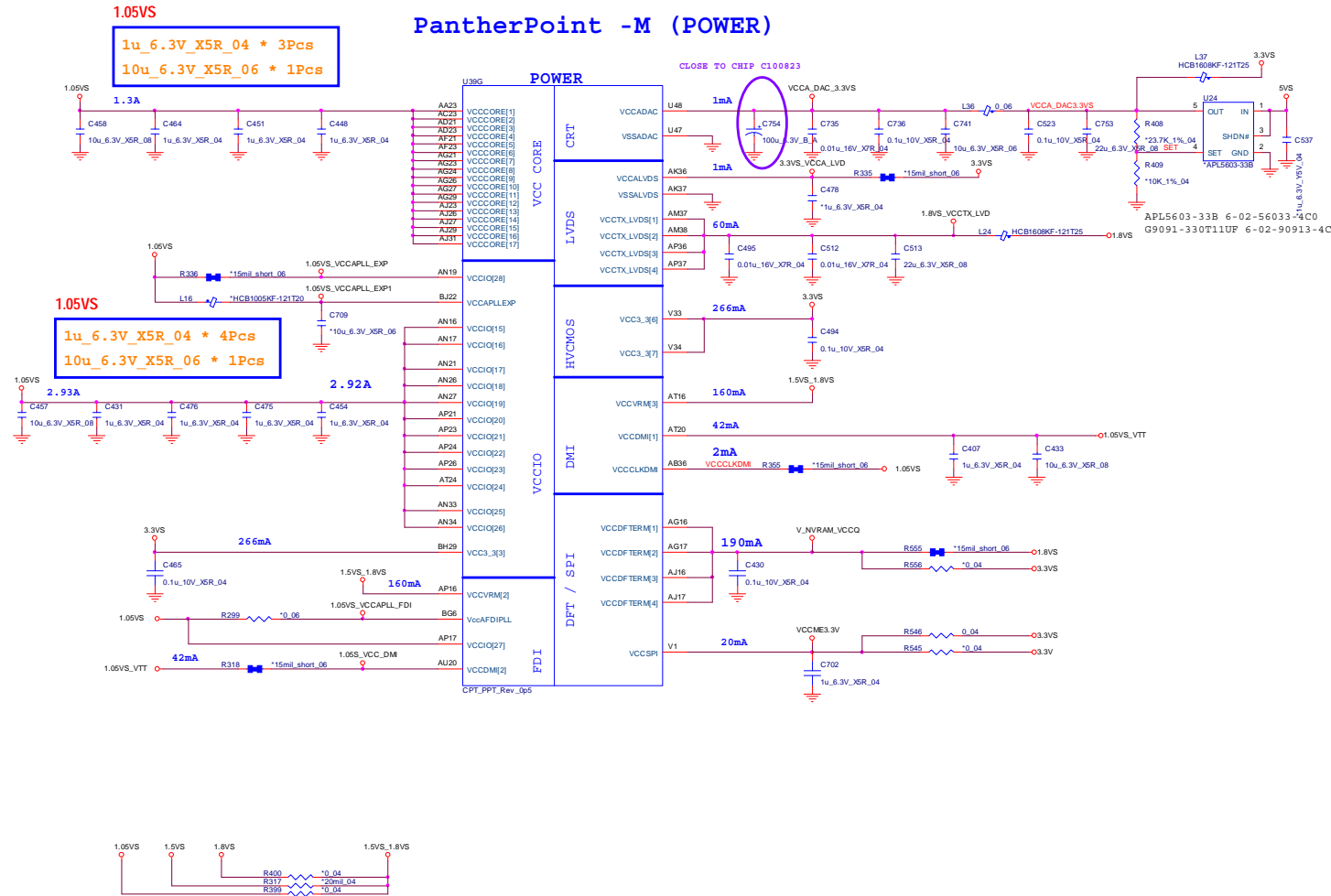

PCH 8/9 POWER

Sheet 25 of 50
PCH 8/9 POWER

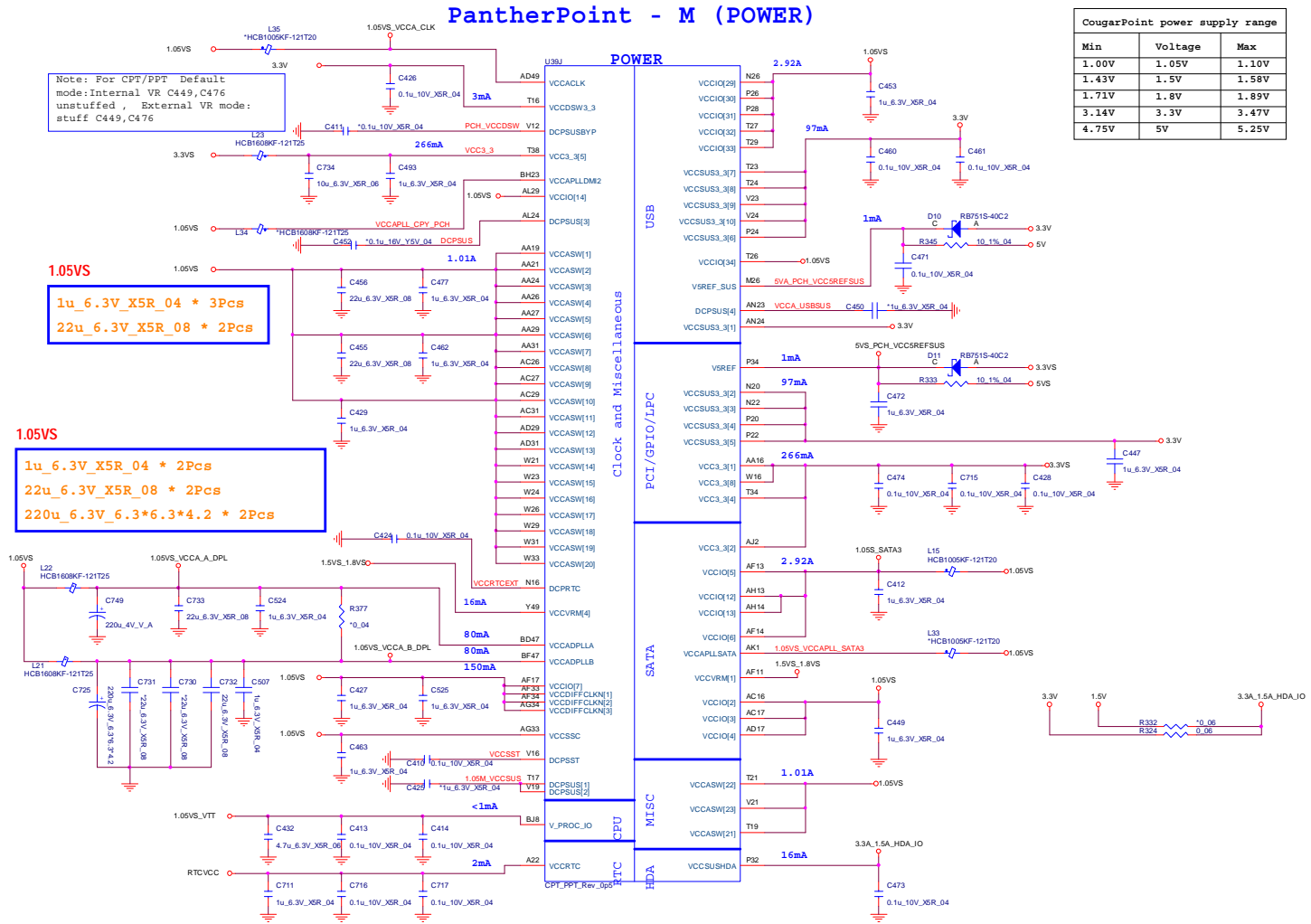

PCH 9/9- GND

PantherPoint -M (GND)

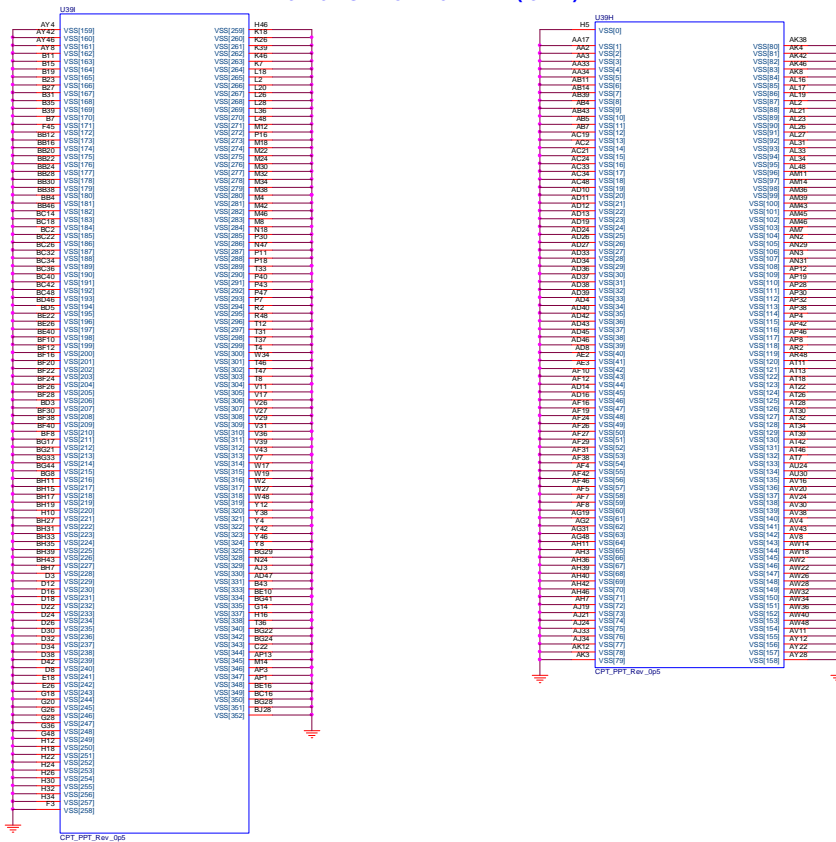

Voltage Rail	Voltage	80 Iccmax Current (A)
V_CPU_IO	1.05	1 (mA)
V5REF	5	1 (mA)
Vcc3_Sus	3.3	0.266
VccADAC3	1.05	1 (mA)
VccADPLLA	1.05	0.08
VccADPLLB	1.05	0.08
VccCore6	1.05	1.3
VccDMI	1.1	0.042
VccIO	1.05	2.925
VccASW	1.05	1.01
VccBPT	3.3	0.020
VccDSW3_3	3.3	2 (mA)
VccDPTERM	1.8	0.19
VccSus3_3	3.3	0.097
VccSusHDA	3.3	1 (mA)
VccVPM	1.5	0.16
VccCLKMI	1.05	0.02
VccSSC	1.05	0.095
VccDIPFCLKM	1.05	0.055
VccALVDS	3.3	1 (mA)
VccTX_LVDS	1.8	0.06

Sheet 26 of 50
PCH 9/9- GND

B.Schematic Diagrams

WLAN, 3G, MINI PCIE

Sheet 27 of 50
WLAN, 3G, MINI
PCIE

3G/MSATA MINI CARD

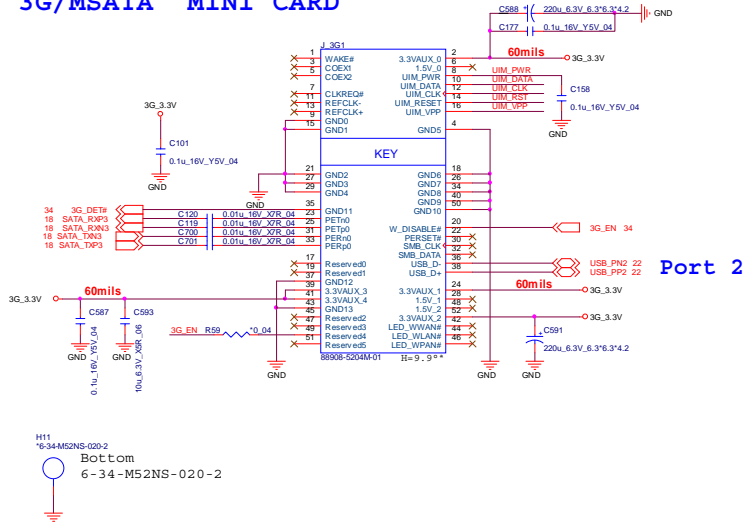

SIM CONN

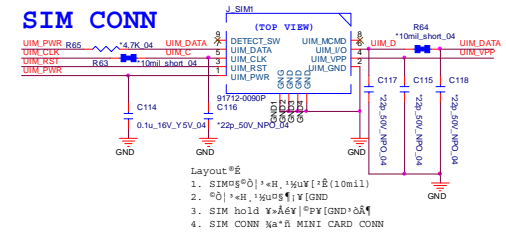

3G POWER

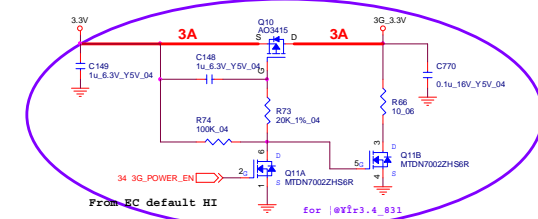

WLAN MINI CARD

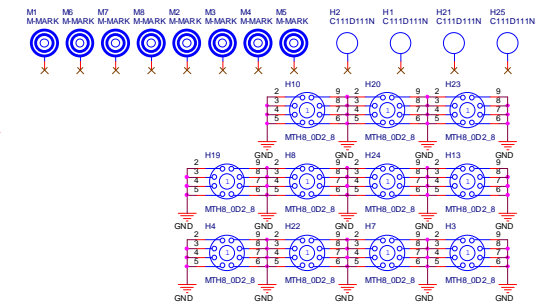
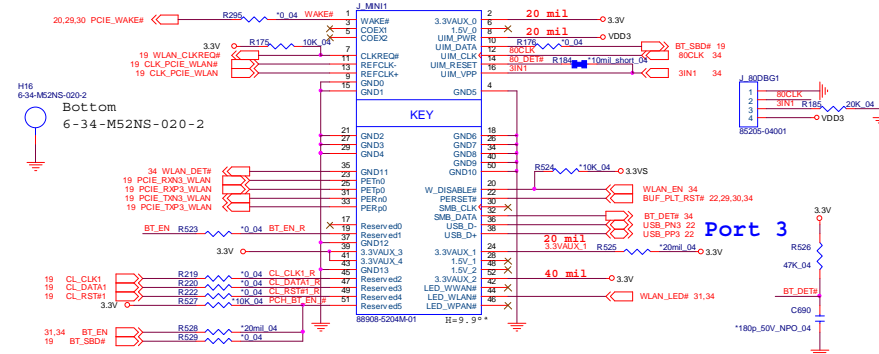

CCD, TPM, MULTI CON

FOR POWER SW BOARD

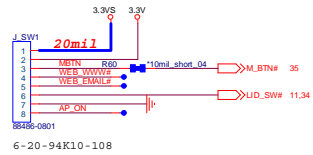

FOR OPTIMUS FUNCTION

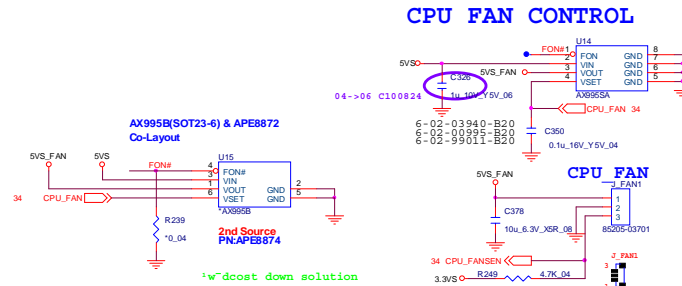

CLICK CONN

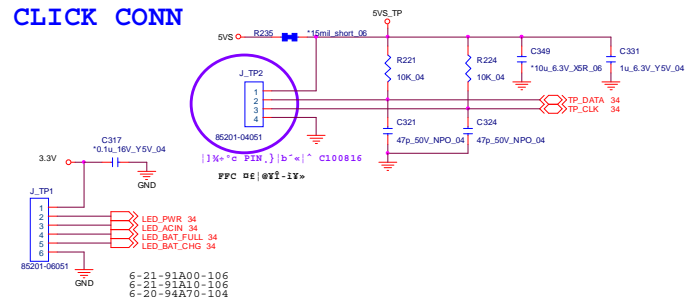

TPM 1.2

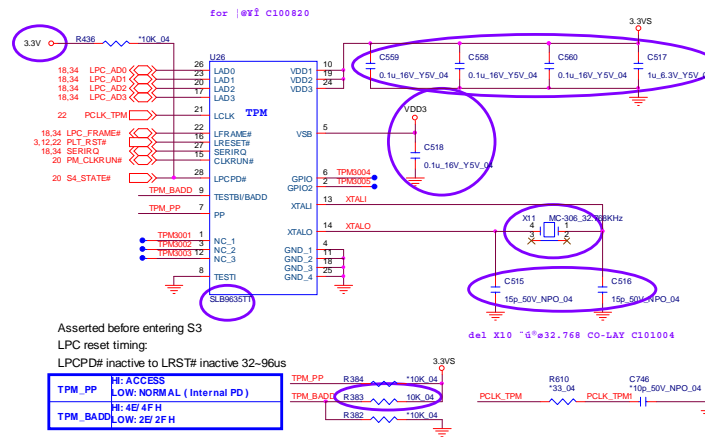

CCD

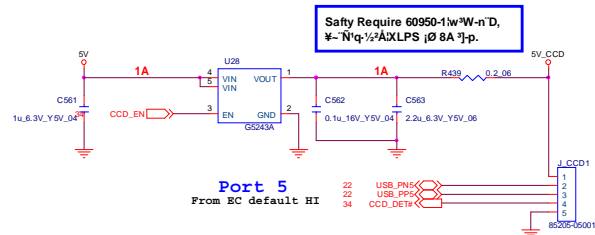

Sheet 28 of 50
CCD, TPM, MULTI
CON

B.Schematic Diagrams

USB3.0

Sheet 29 of 50
USB3.0

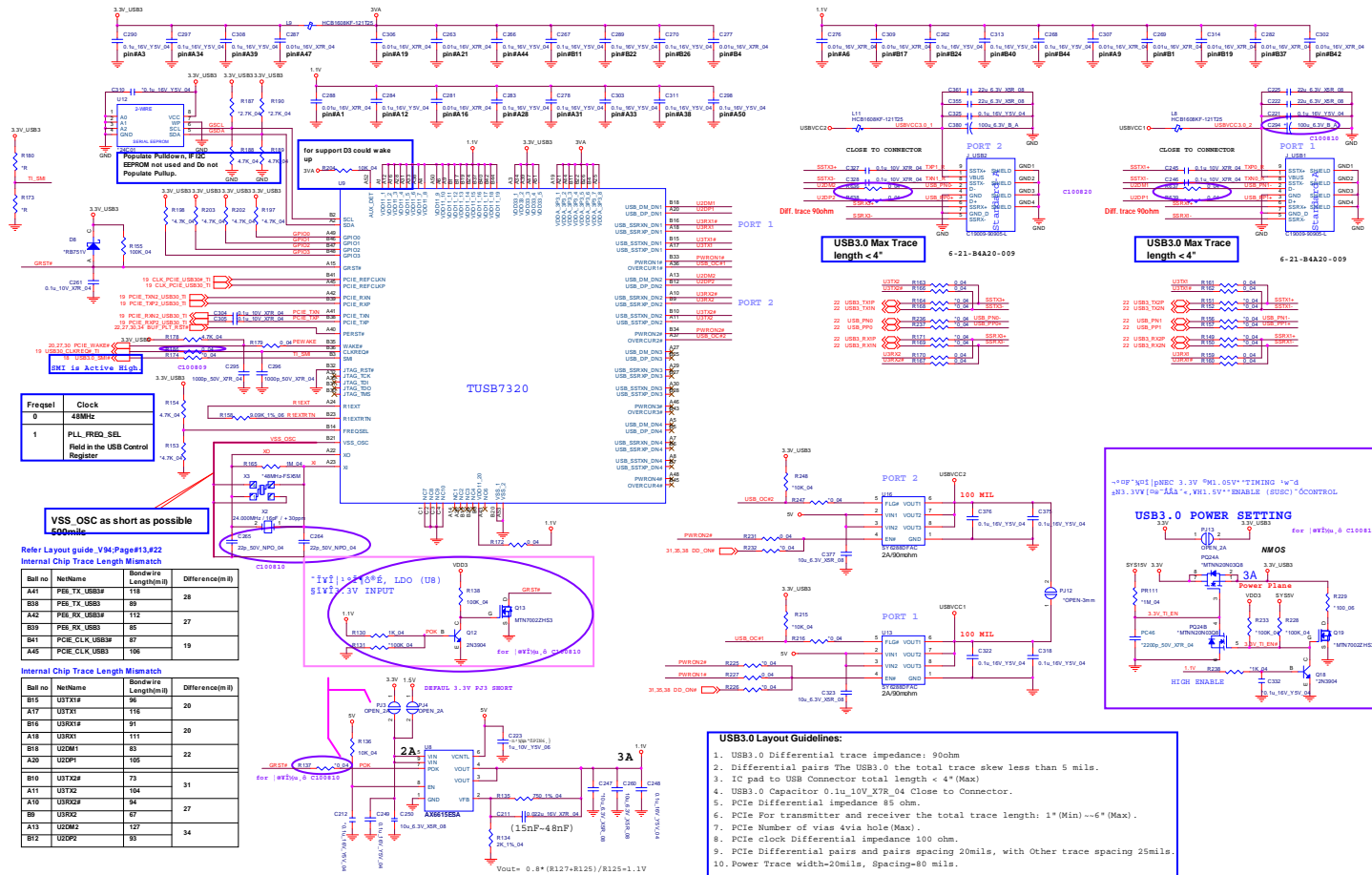

Card Reader (RTL8411)

RTL8411

LAN_VDD33 Rising Time; G
1ms ~ 100ms

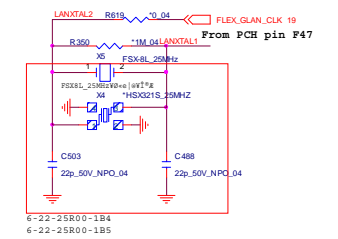
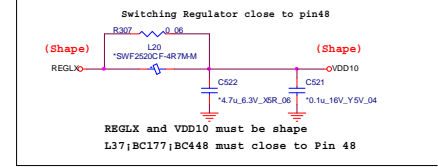
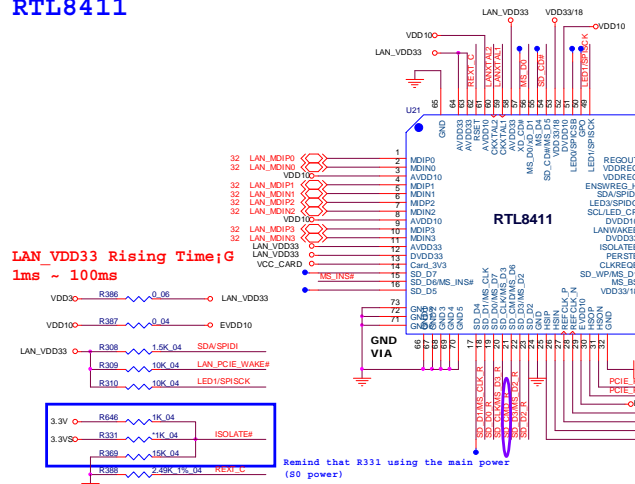

Sheet 30 of 50
Card Reader
(RTL8411)

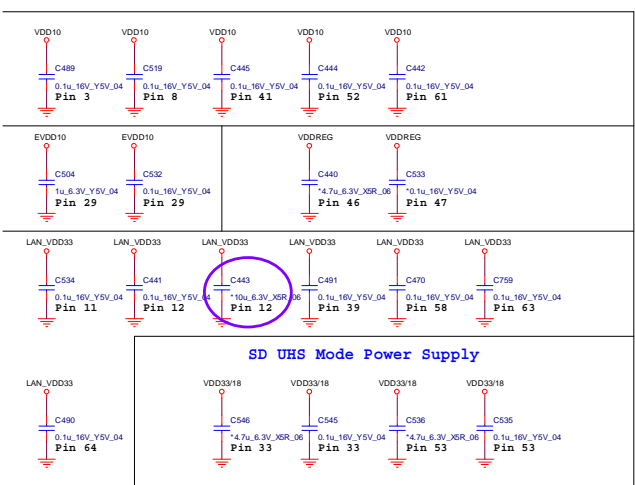
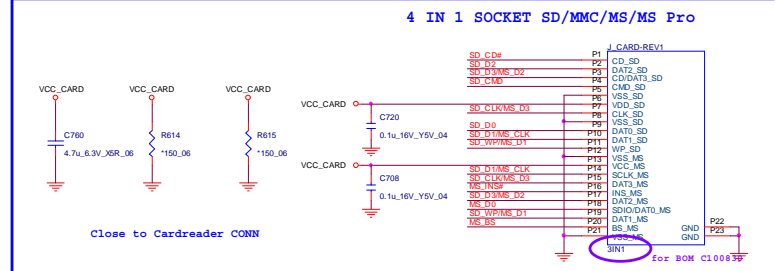
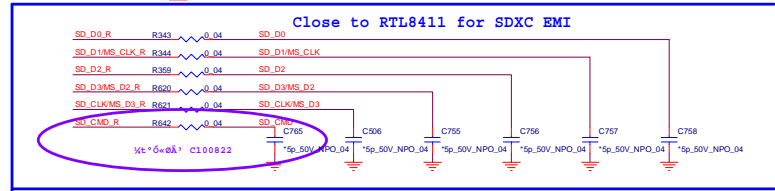

B.Schematic Diagrams

SATA ODD, LED, USB CHARGE

RTL8411

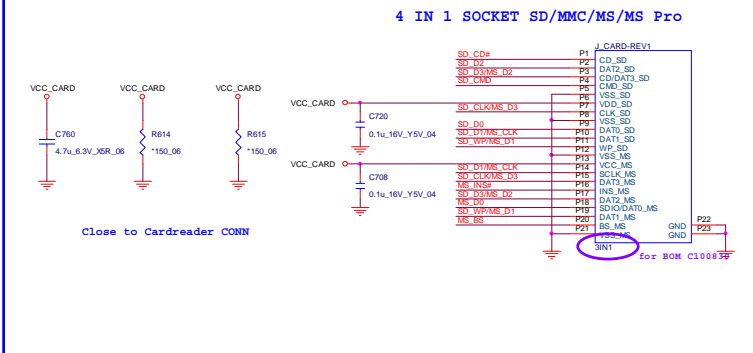
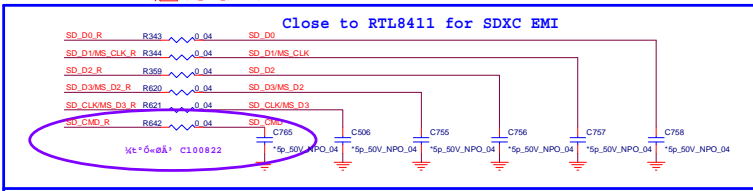
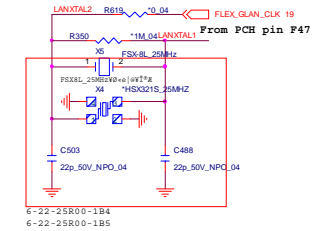
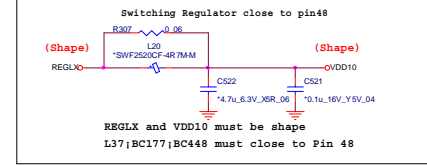
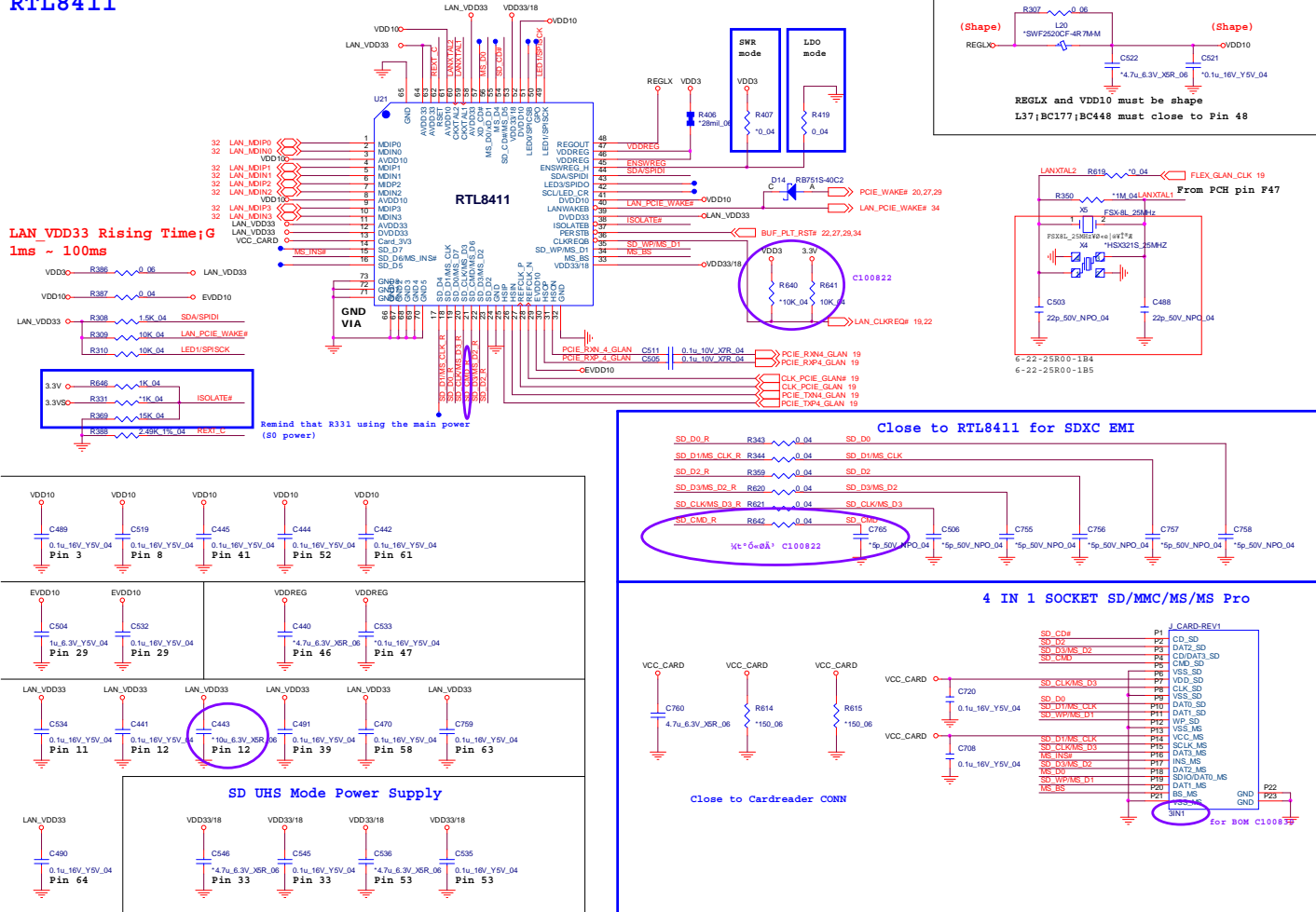

B.Schematic Diagrams

Sheet 31 of 50
SATA ODD, LED,
USB CHARGE

HDMI, RJ45

LAN PORT GIGA LAN (JMC251C)

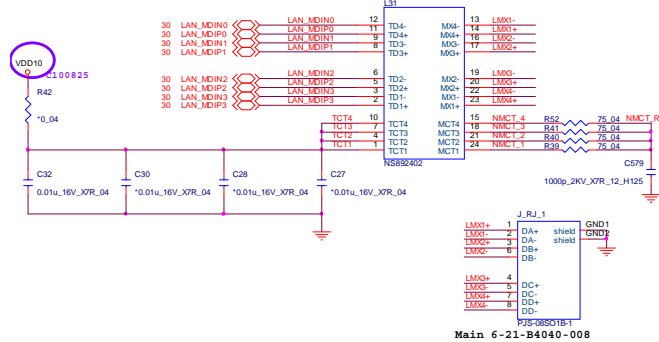

FOR W/O LEVEL SHIFT

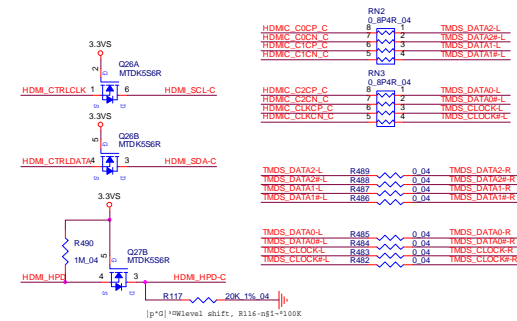

FOR INTEL GRAPHIC

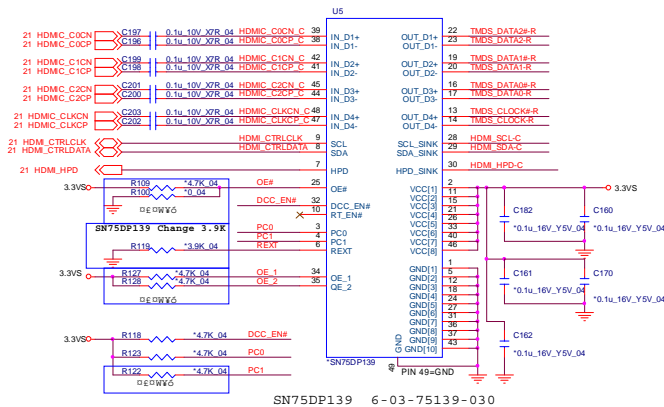

HDMI CONNECTOR

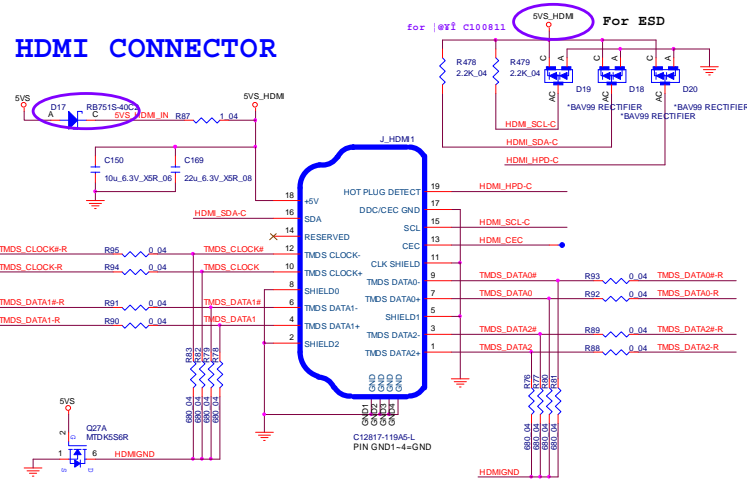

Sheet 32 of 50
HDMI, RJ45

B.Schematic Diagrams

AUDIO CODEC VT1802P

CODEC (ALC269 & VT1802P)

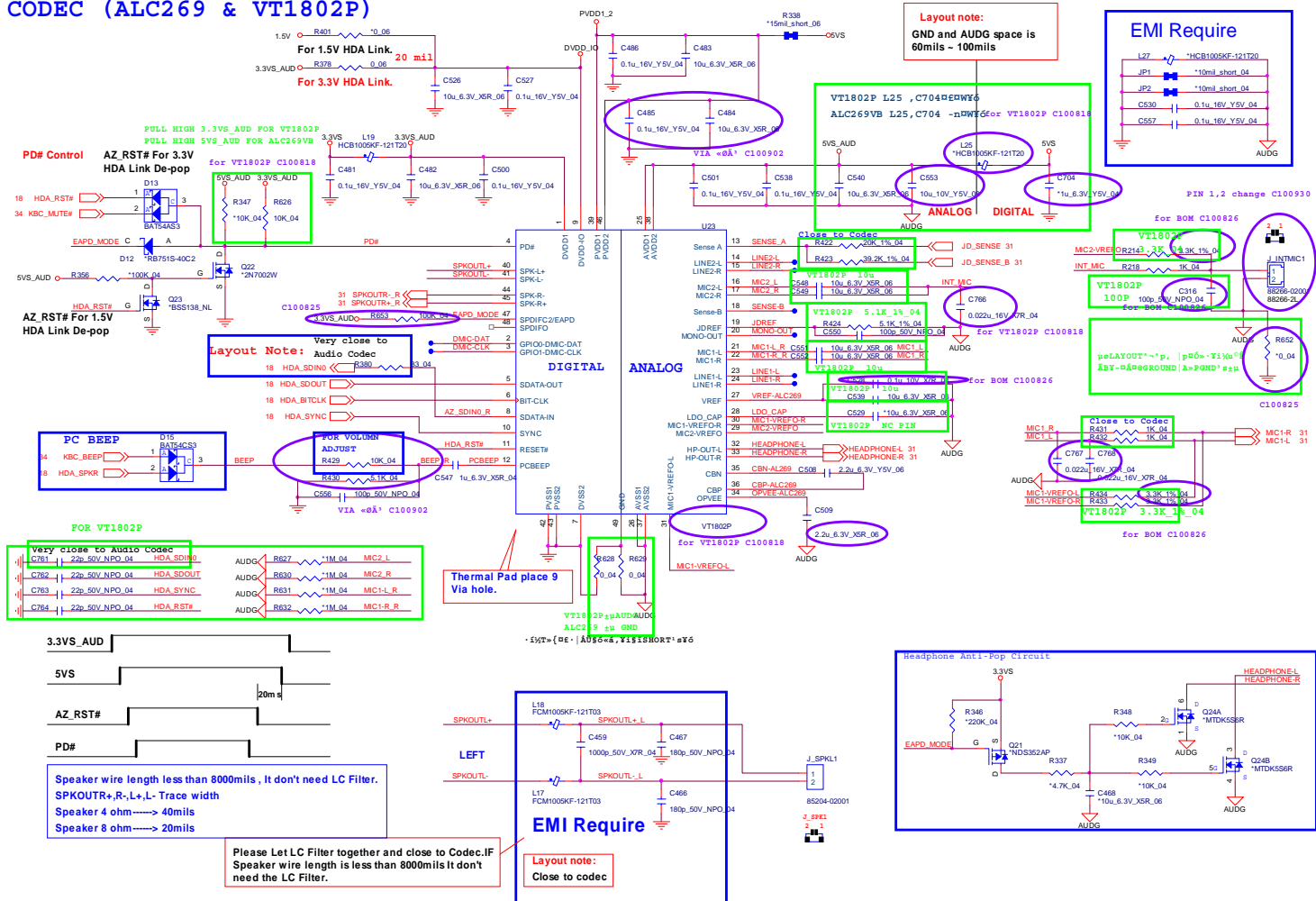

Sheet 33 of 50
AUDIO CODEC
VT1802P

KBC-ITE IT8518E

B.Schematic Diagrams

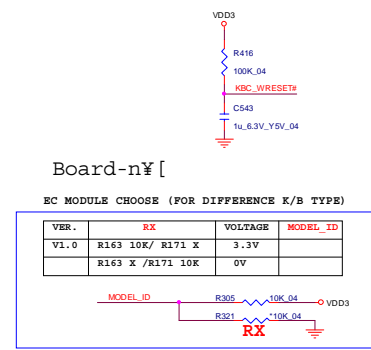
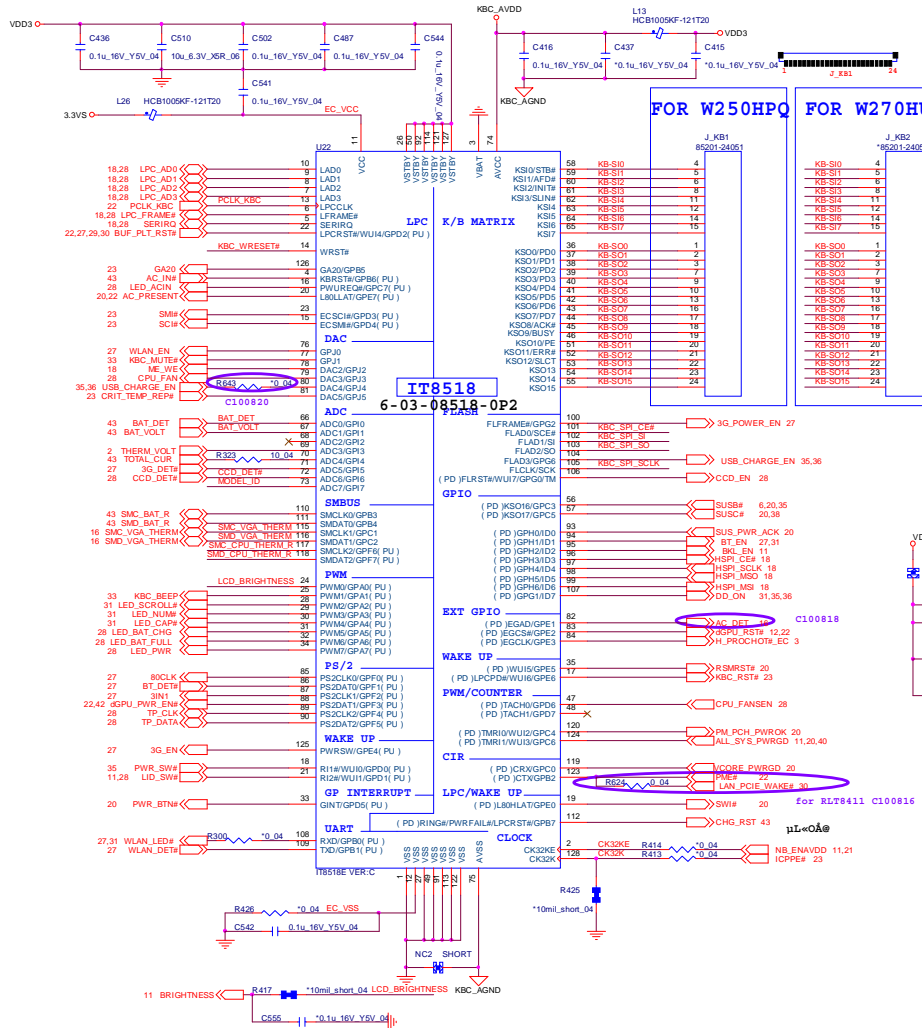

Sheet 34 of 50
KBC-ITE IT8518E

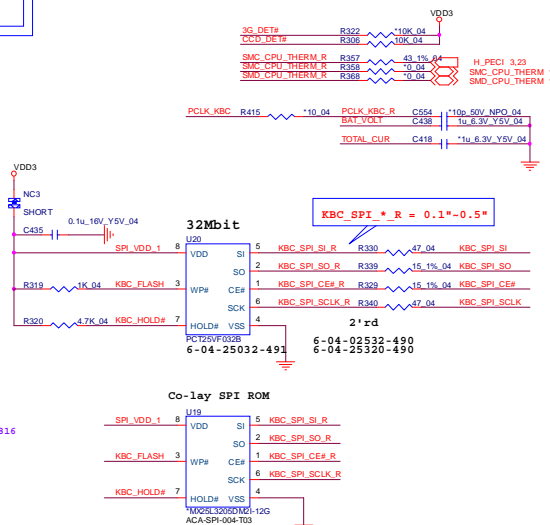

Schematic Diagrams

5VS, 3VS, 1.5VS CPU

B.Schematic Diagrams

Sheet 35 of 50
5VS, 3VS, 1.5VS
CPU

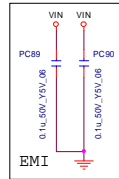
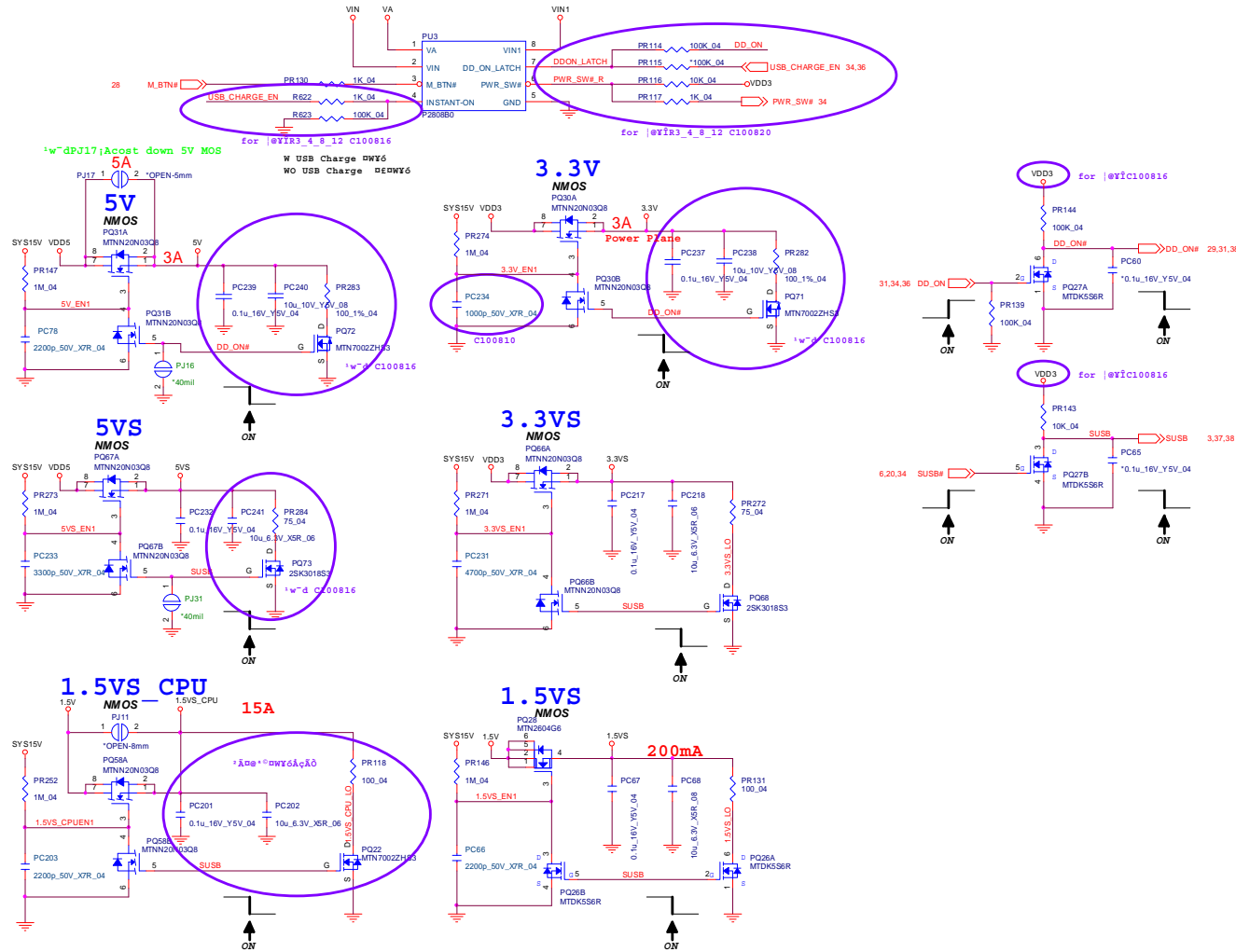

VDD3, VDD5

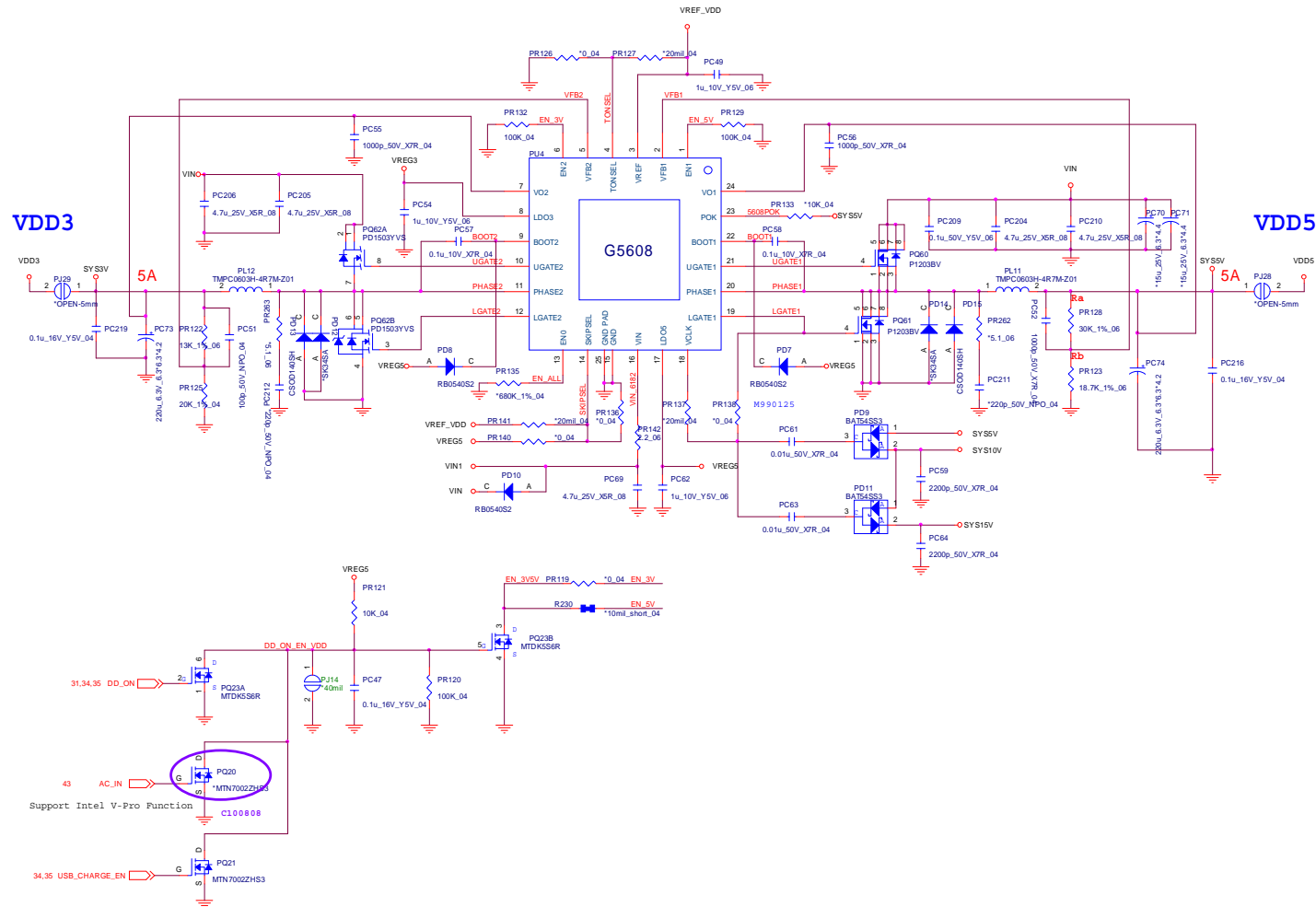

Sheet 36 of 50
VDD3, VDD5

B.Schematic Diagrams

Schematic Diagrams

Power 0.85VS, 1.8VS

B.Schematic Diagrams

Sheet 37 of 50
Power 0.85VS,
1.8VS

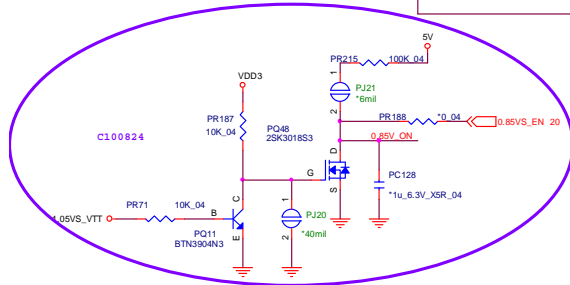
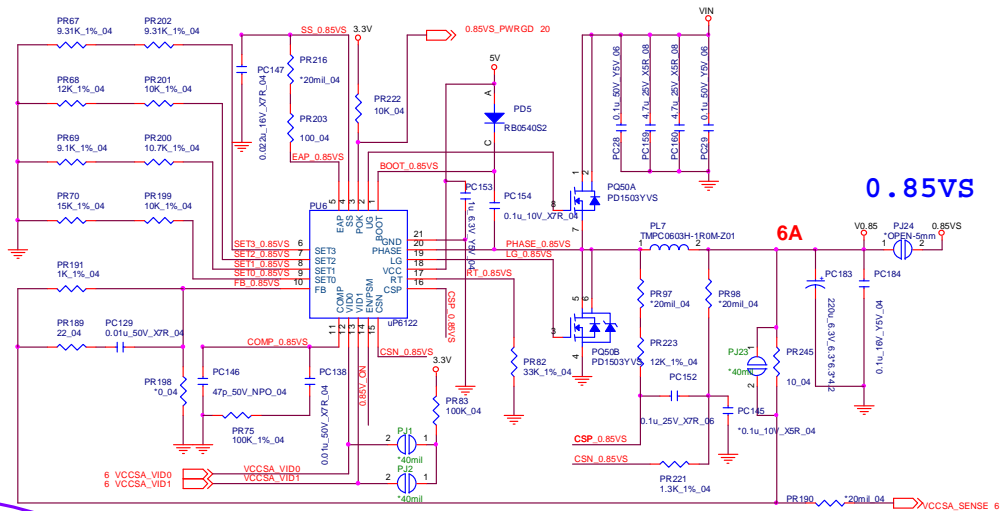
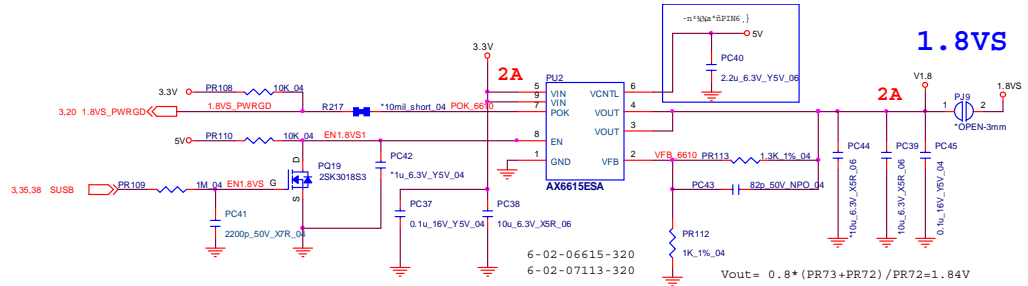

	0.9V	0.8V	0.725V	0.675V
VCCSA_VID0	0	0	1	1
VCCSA_VID1	0	1	0	1
	SET0	SET2	SET1	SET3

POWER 1.5V/1.05VS

Sheet 38 of 50
POWER 1.5V/
1.05VS

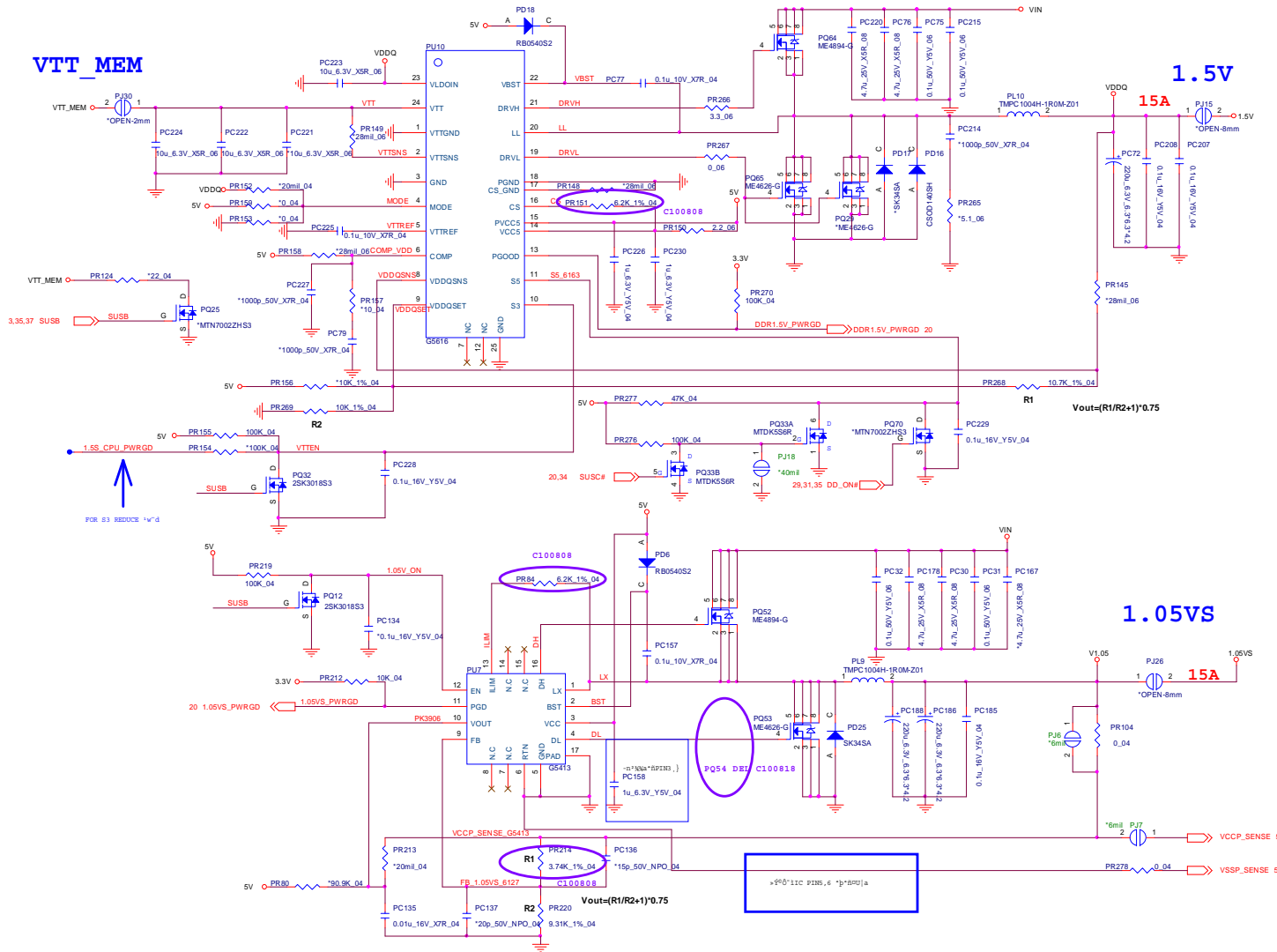

POWER 1.05V/1.05VS VTT

Sheet 39 of 50
POWER 1.05VS/
1.05VS VTT

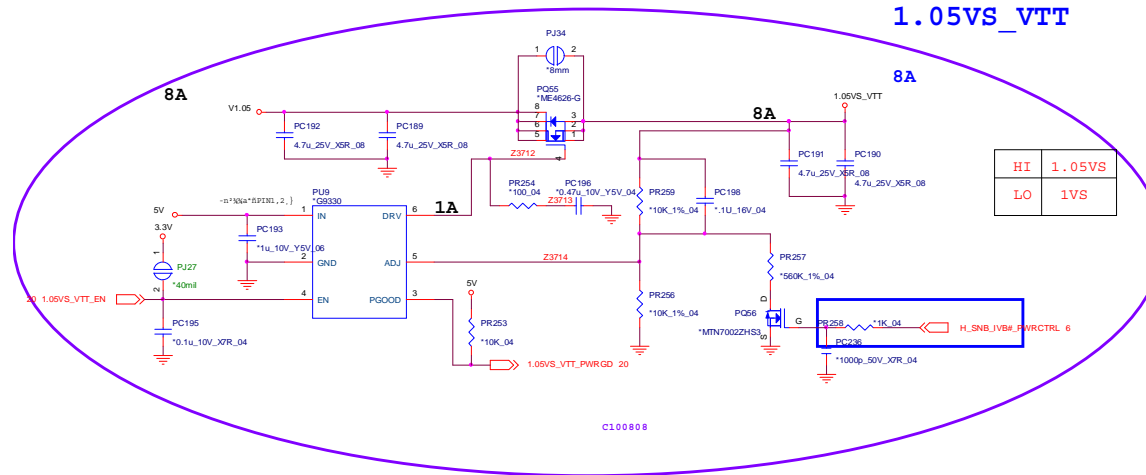
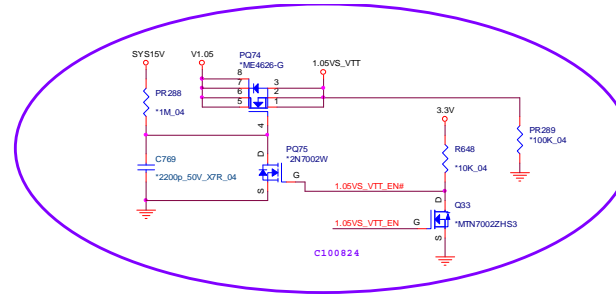

POWER VCORE1

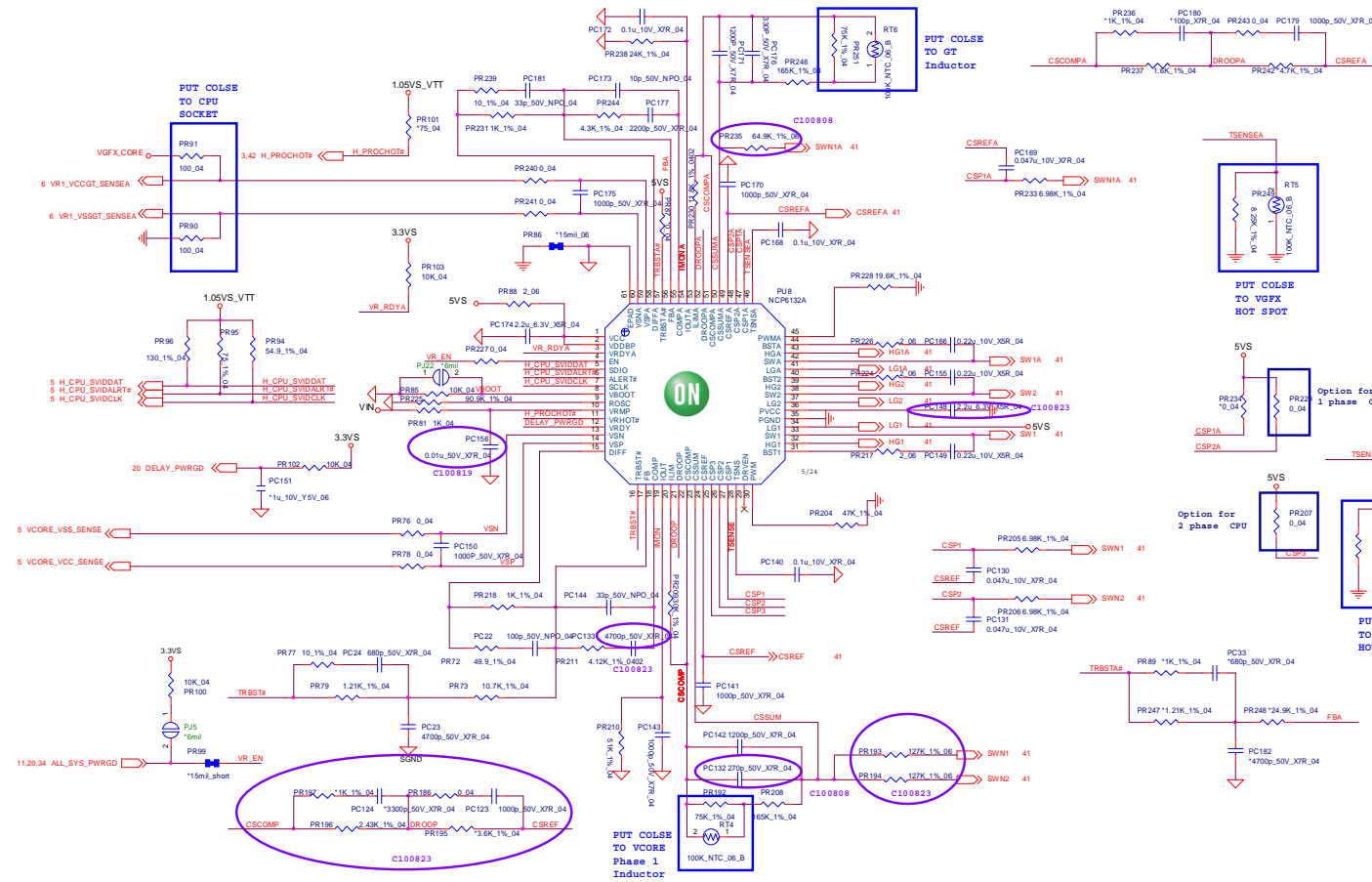

Sheet 40 of 50
POWER VCORE1

B.Schematic Diagrams

POWER VCORE2

Sheet 41 of 50
POWER VCORE2

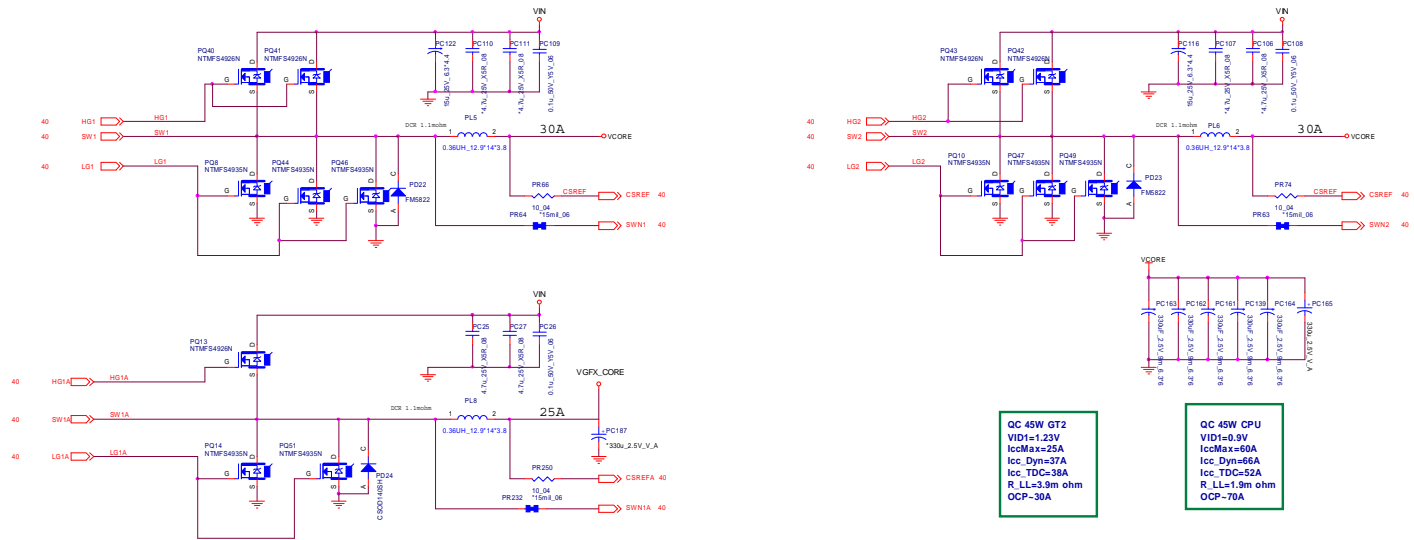

QC 45W GT2
VID1=1.23V
IccMax=25A
Icc_Dyn=37A
Icc_TDC=38A
R_LL=3.9m ohm
OCP=30A

QC 45W CPU
VID1=0.9V
IccMax=60A
Icc_Dyn=66A
Icc_TDC=52A
R_LL=1.9m ohm
OCP=70A

Power VGA NVVDD/PEX_VDD

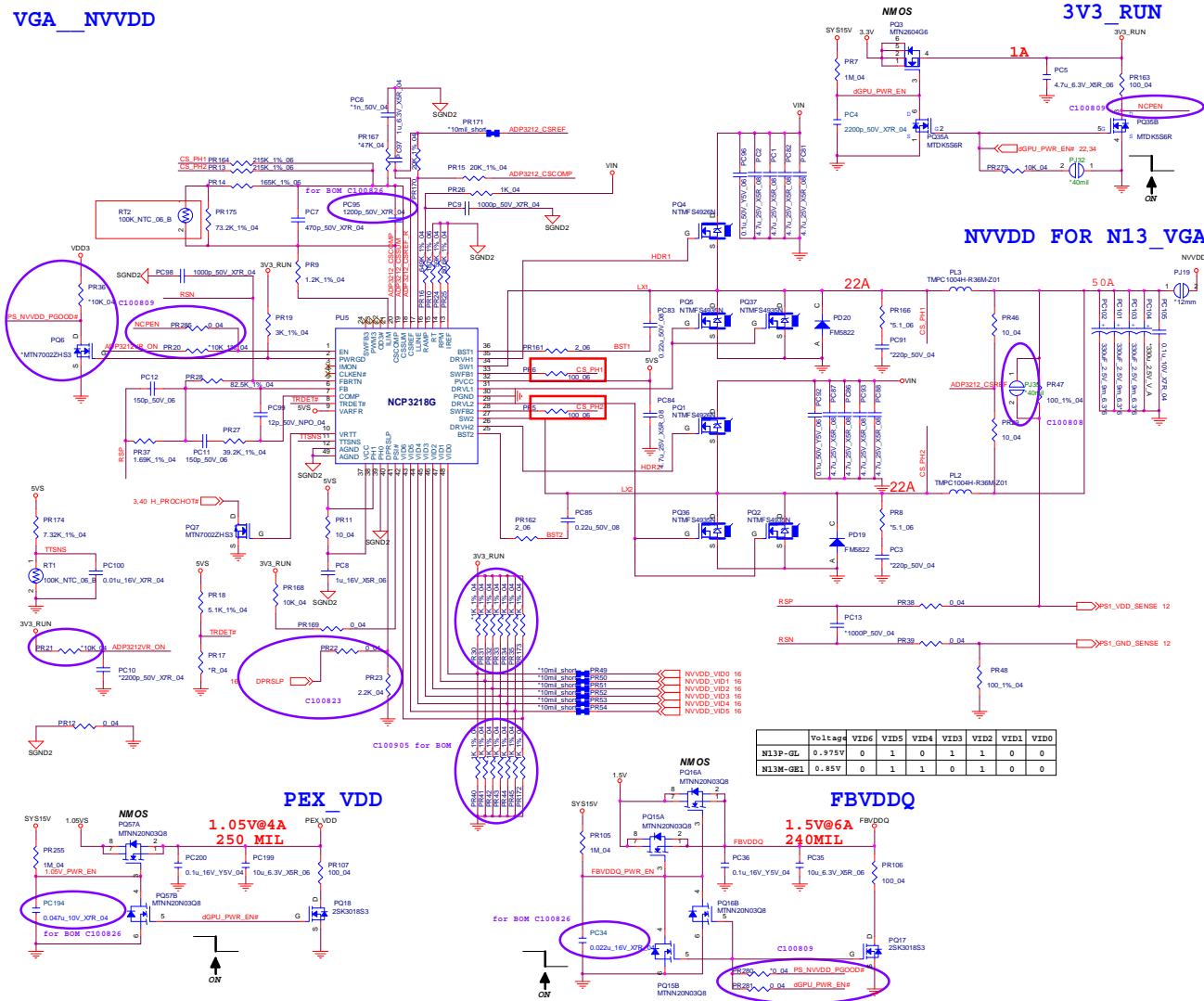

Sheet 42 of 50
Power VGA
NVVDD/PEX_VDD

B.Schematic Diagrams

AC IN, CHARGER

Sheet 43 of 50
AC IN, CHARGER

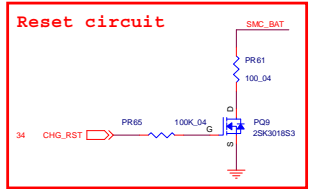
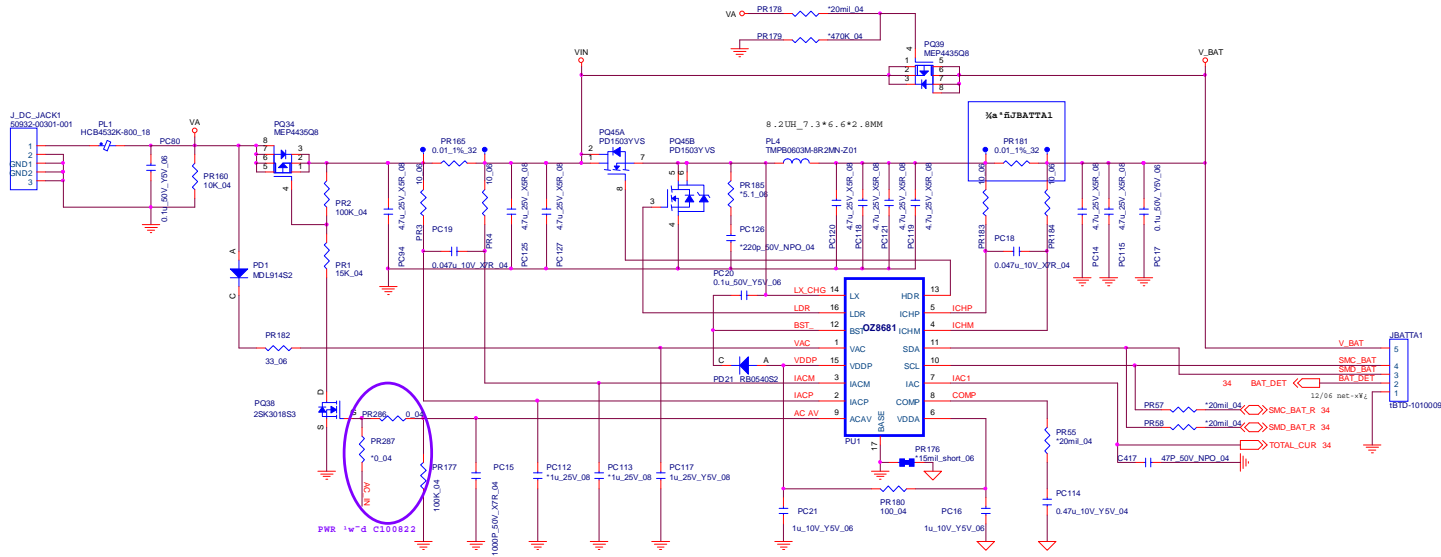

PCB Layout notes

- 1) All power traces should be routed on the outer layers
GNDP, VAD, VSYS, LX, VCHG, VBATT
- 2) Use Kelvin connections for R3, R4
(separate force and measurement traces)
- 3) R23 and R24 are dummy resistors, for layout purposes only
(serves as single point connection between GNDP & GNDA)
- 4) Footprint TO-236 is equivalent to SOT-23
- 5) Footprint SIP1P is a single hole axial pad
- 6) All resistors, capacitors and semiconductors are SMD
- 7) Potentiometers, and test points are axial devices

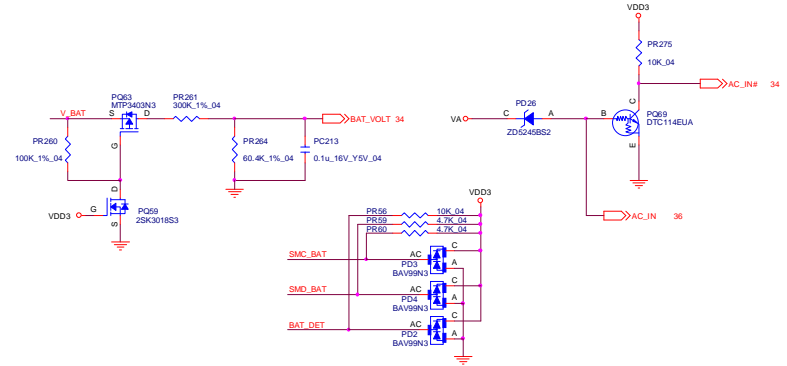

AUDIO BOARD

USB PORT

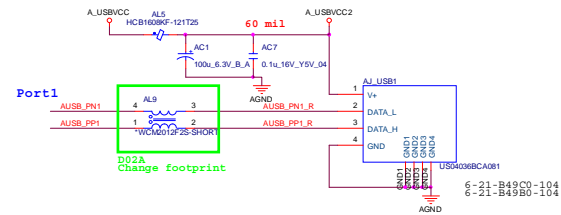

TO M/B

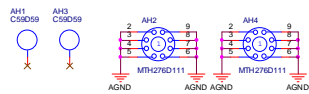
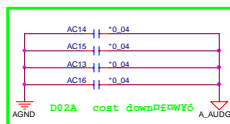
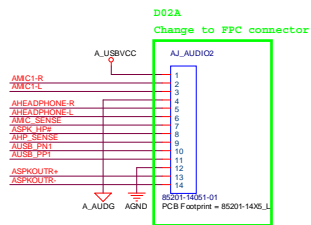

AUDIO JACK

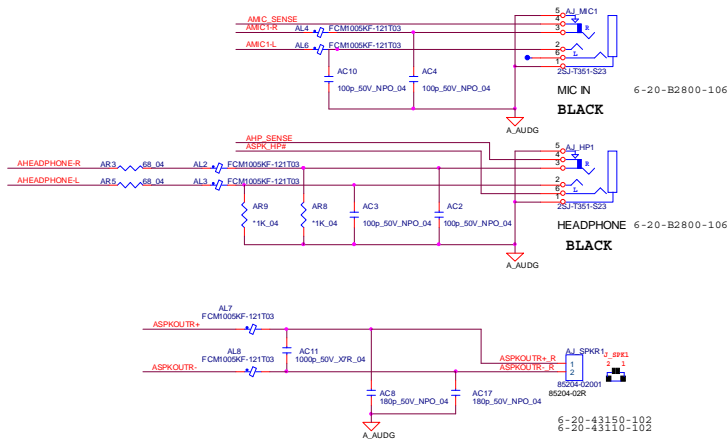

Sheet 44 of 50
AUDIO BOARD

CLICK BOARD

CLICK BOARD

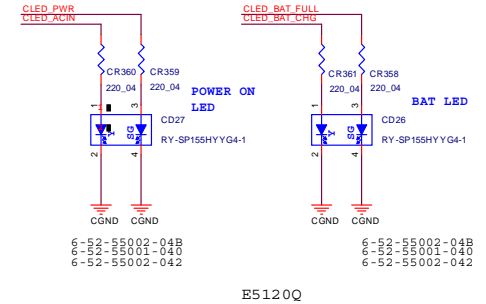
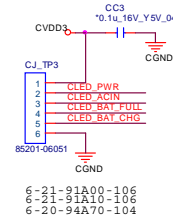
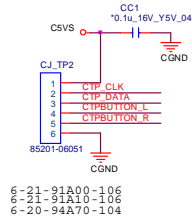
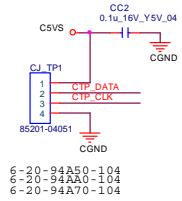

Sheet 45 of 50
CLICK BOARD

B.Schematic Diagrams

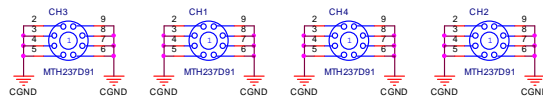
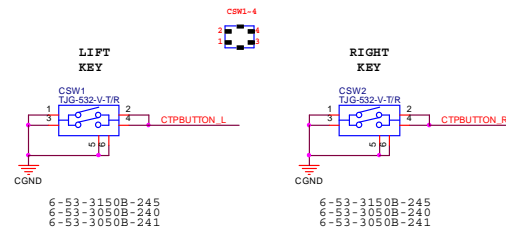

W251HPQ POWER SW BOARD

POWER SW & LED

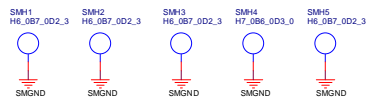
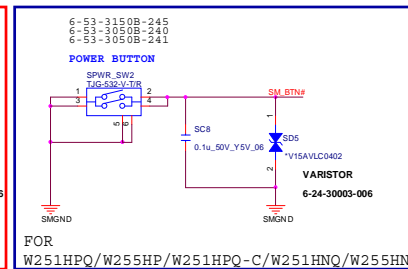
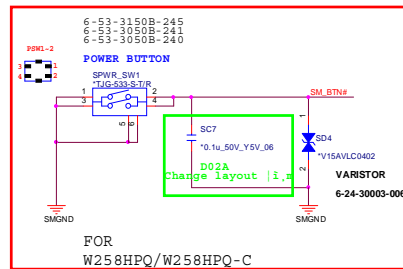
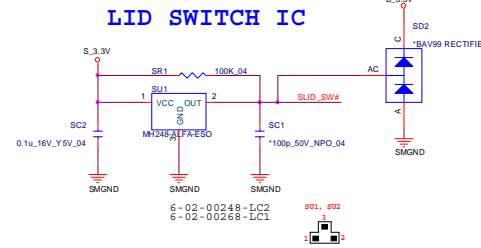
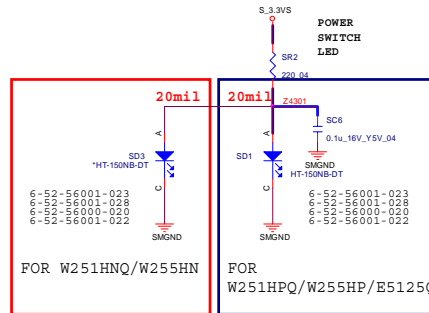
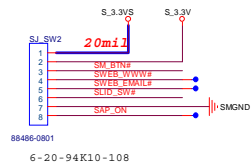

Sheet 46 of 50
W251HPQ POWER
SW BOARD

W270HU BRIDGE ODD BOARD

ODD BOARD FOR W270HU

Sheet 47 of 50
W270HU BRIDGE
ODD BOARD

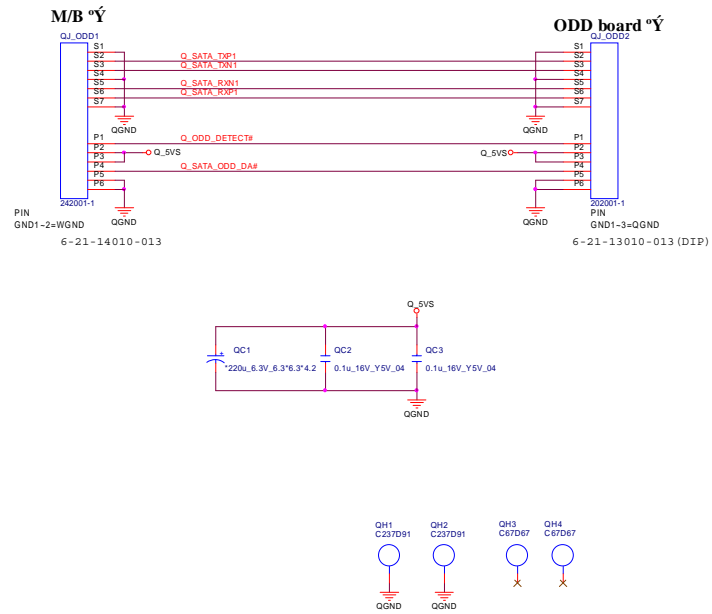

W270HU POWER SW BOARD

POWER SW & LED

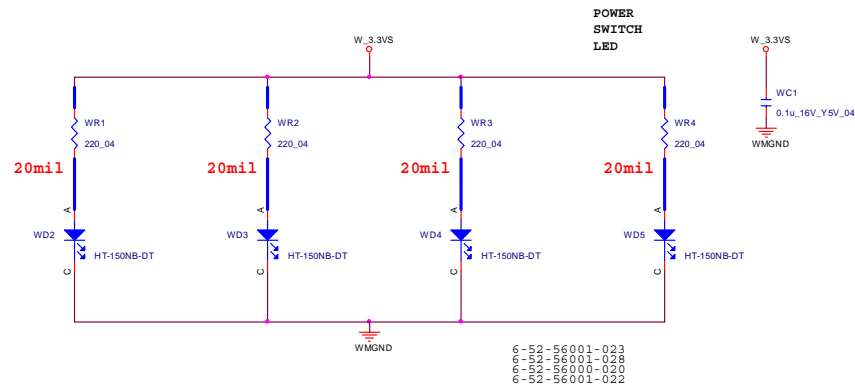

LID SWITCH IC

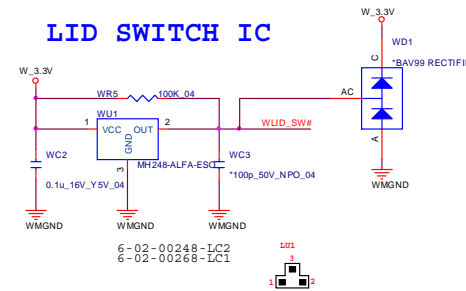

Sheet 48 of 50
W270HU POWER
SW BOARD

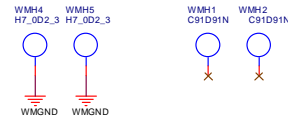
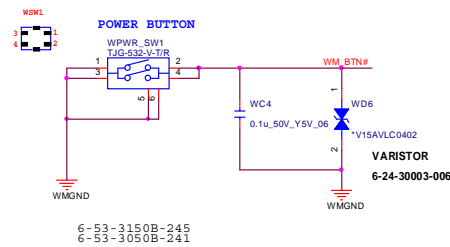
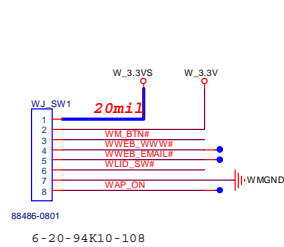

Power Diagram

Sheet 49 of 50
Power Diagram

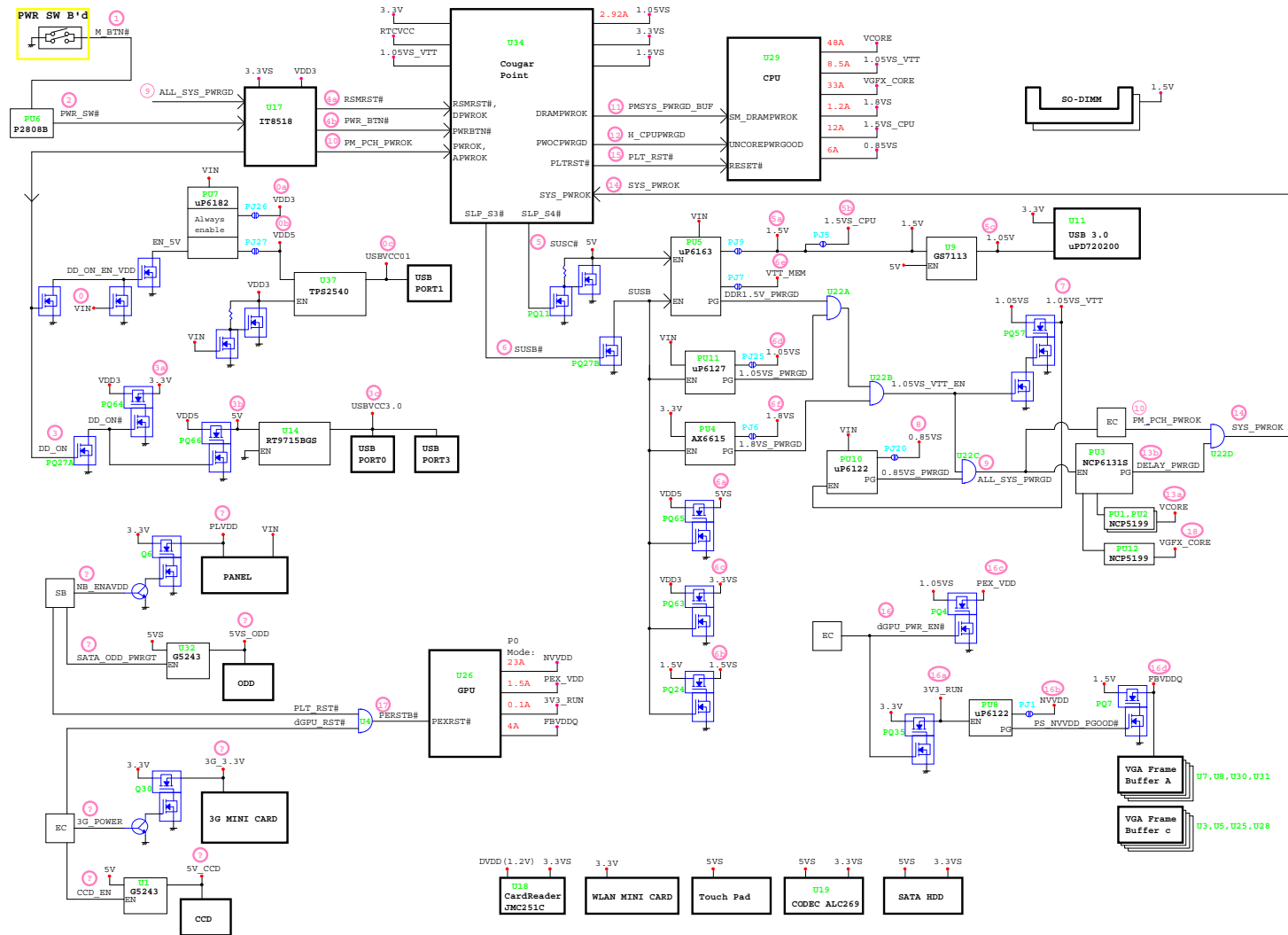

Power On SEQ

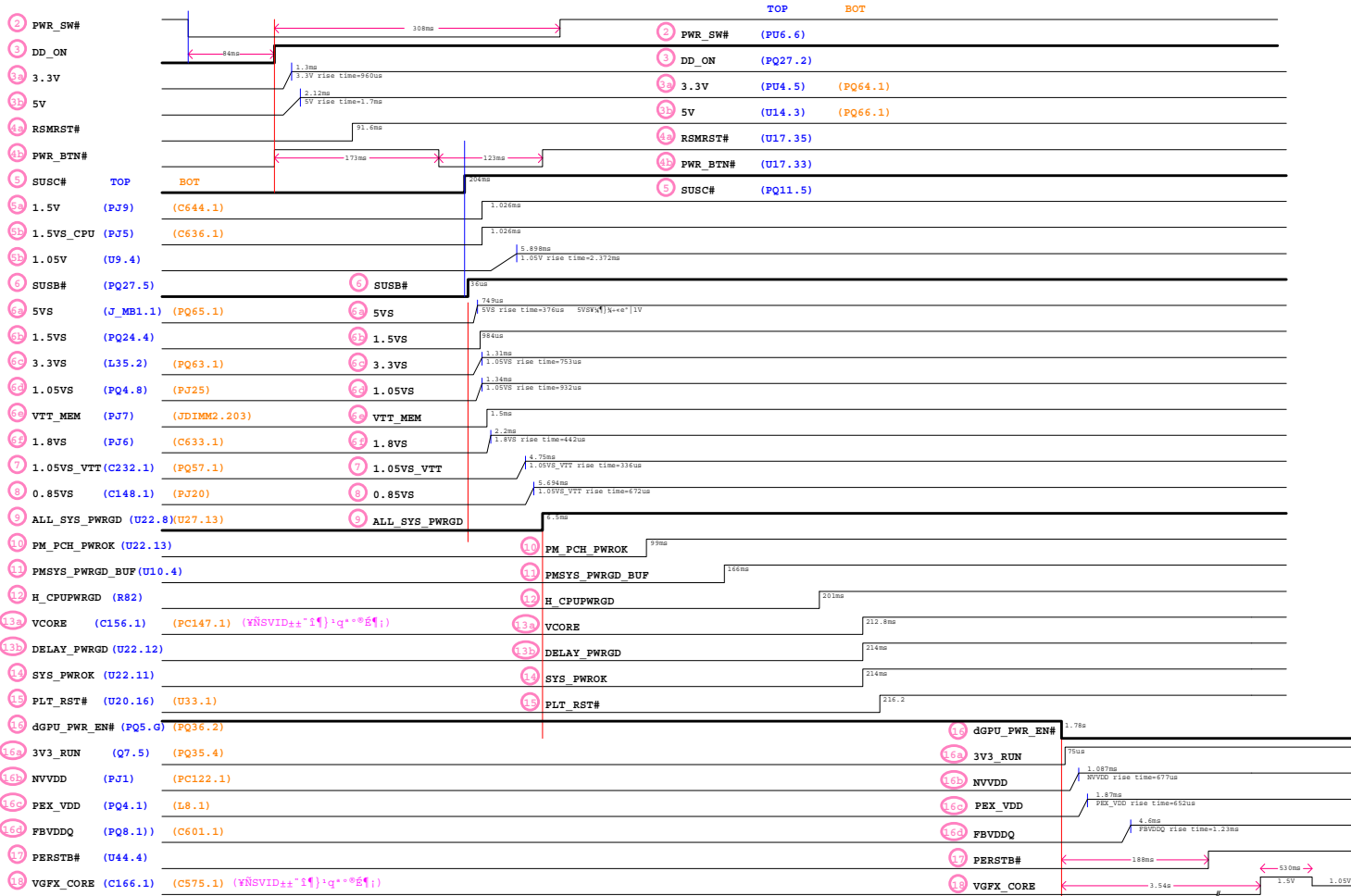

Sheet 50 of 50
Power On SEQ

Schematic Diagrams

Appendix C: Updating the FLASH ROM BIOS

To update the FLASH ROM BIOS, you must:

- Download the BIOS update from the web site.
- Unzip the files onto a bootable CD/DVD/USB Flash Drive.
- Reboot your computer from an external CD/DVD/USB Flash Drive.
- Use the flash tools to update the flash BIOS using the commands indicated below.
- Restart the computer booting from the HDD and press **F2** at startup enter the BIOS.
- Load setup defaults from the BIOS and save the default settings and exit the BIOS to restart the computer.
- After rebooting the computer you may restart the computer again and make any required changes to the default BIOS settings.

Download the BIOS

1. Go to www.clevo.com.tw and point to **E-Services** and click **E-Channel**.
2. Use your user ID and password to access the appropriate download area (BIOS), and download the latest BIOS files (the BIOS file will be contained in a batch file that may be run directly once unzipped) for your computer model (see sidebar for important information on BIOS versions).

Unzip the downloaded files to a bootable CD/DVD/ or USB Flash drive

1. Insert a bootable CD/DVD/USB flash drive into the CD/DVD drive/USB port of the computer containing the downloaded files.
2. Use a tool such as Winzip or Winrar to unzip all the BIOS files and refresh tools to your bootable CD/DVD/USB flash drive (you may need to create a bootable CD/DVD with the files using a 3rd party software).

Set the computer to boot from the external drive

1. With the bootable CD/DVD/USB flash drive containing the BIOS files in your CD/DVD drive/USB port, restart the computer and press **F2** (in most cases) to enter the BIOS.
2. Use the arrow keys to highlight the **Boot** menu.
3. Use the “+” and “-” keys to move boot devices up and down the priority order.
4. Make sure that the CD/DVD drive/USB flash drive is set first in the boot priority of the BIOS.
5. Press **F4** to save any changes you have made and exit the BIOS to restart the computer.



BIOS Version

Make sure you download the latest correct version of the BIOS appropriate for the computer model you are working on.

You should only download BIOS versions that are **V1.01.XX or higher** as appropriate for your computer model.

Note that BIOS versions are not backward compatible and therefore you may not downgrade your BIOS to an older version after upgrading to a later version (e.g if you upgrade a BIOS to ver 1.01.05, you **MAY NOT** then go back and flash the BIOS to ver 1.01.04).

BIOS Update

Use the flash tools to update the BIOS

1. Make sure you are not loading any memory management programs such as HIMEM by holding the **F8** key as you see the message “**Starting MS-DOS**”. You will then be prompted to give “**Y**” or “**N**” responses to the programs being loaded by DOS. Choose “**N**” for any memory management programs.
2. You should now be at the DOS prompt e.g: DISK C:\> (C is the designated drive letter for the CD/DVD drive/USB flash drive).
3. **Type the following command** at the DOS prompt:

C:\> Flash.bat

4. The utility will then proceed to flash the BIOS.
5. You should then be prompted to press any key to restart the system or turn the power off, and then on again but make sure you remove the CD/DVD/USB flash drive from the CD/DVD drive/USB port before the computer restarts.

Restart the computer (booting from the HDD)

1. With the CD/DVD/USB flash drive removed from the CD/DVD drive/USB port the computer should restart from the HDD.
2. Press **F2** as the computer restarts to enter the BIOS.
3. Use the arrow keys to highlight the **Exit** menu.
4. Select **Load Setup Defaults** (or press **F3**) and select “**Yes**” to confirm the selection.
5. Press **F4** to save any changes you have made and exit the BIOS to restart the computer.

Your computer is now running normally with the updated BIOS

You may now enter the BIOS and make any changes you require to the default settings.