



ADPCM VOICE SYNTHESIZER (PowerSpeech™)

Table of Contents-

1.	GENERAL DESCRIPTION	2
2.	FEATURES	2
3.	PAD CONFIGURATIONS	3
4.	PAD DESCRIPTION	4
5.	BLOCK DIAGRAM	5
6.	FUNCTIONAL DESCRIPTION	5
6.1	Instruction Set Description	5
6.2	Conditional Instructions	9
6.3	End Instruction	9
6.4	Program Structure Features and Execution Rules	9
6.5	Mask Options	10
6.6	Speech Equation Description	10
6.7	Programmable Power-on Initialization	11
6.8	Progammig Examples	11
7.	ELECTRICAL CHARACTERISTICS	14
7.1	Absolute Maximum Ratings	14
7.2	DC Characteristics	14
8.	APPLICATION CIRCUIT	15
8.1	Supplement	15
9.	REVISION HISTORY	17



1. GENERAL DESCRIPTION

The W528Sxx family is programmable speech synthesis ICs that utilize the ADPCM coding method to generate all types of voice effects.

The W528Sxx's LOAD and JUMP commands and four programmable registers provide powerful user-programmable functions that make this chip suitable for an extremely wide range of speech IC applications.

The W528Sxx family includes 9 kinds of part numbers with the same function except for the voice duration shown below:

ITEM	W528S03	W528S05	W528S08A	W528S10	W528S12	W528S15
Second	3 Sec	5 Sec	8 Sec	10 Sec	12 Sec	15 Sec
ITEM	W528S20	W528S25	W528S30			
Second	20 Sec	25 Sec	30 Sec			

Note: The voice durations are estimated by various sampling rate.

2. FEATURES

- Programmable speech synthesizer
- Wide operating voltage range: 2.4 to 5.5 volts
- 4-bit ADPCM synthesis method
- Provides 4 direct trigger inputs that can easily be extended to 8 or 12 matrix trigger inputs
- Two trigger input debounce times (20 to 40 mS or 160 to 320 μ S) can be set
- Provides up to 2 LEDs and 3 STOP outputs
- Every LED pin can drive 3 LEDs simultaneously
- LED flash frequency: 3 Hz
- AUD output current: 5 mA
- Flexible functions programmable through the following:
 - LD (load), JP (jump) commands
 - Four registers: R0, EN, STOP, and MODE
 - Conditional instructions
 - Speech equation
 - END instruction
 - Global repeat (GR) setting
 - Output frequency and LED flash type setting
- Programmable power-on initialization (POI) (can be interrupted by trigger inputs)
- POI delay time of 160 mS ensures stable voltage when chip is powered on
- Can be programmed for the following functions:

- Interrupt or non-interrupt for rising or falling edge of each trigger pin (this feature determines retriggerable, non-retriggerable, overwrite, and non-overwrite features of each trigger pin)
- Four playing modes:
 - One Shot (OS)
 - Level Hold (LH)
 - Single-cycle level hold (S_LH)
 - Complete-cycle level hold (C_LH)
- Stop output signal setting
- Serial, direct, or random trigger mode setting
- Four frequency options (4/4.8/6/8 KHz) and LED On/Off control can be set independently in each GO instruction of speech equation
- Independent control of LED1 and LED2
- Total of 256 voice group entries available for programming
- Provides the following mask options:
 - LED flash type: synchronous/alternate
 - LED1 section-controlled: Yes/No
 - LED2: section-controlled/STPC-controlled
 - LED volume-controlled: No/Yes

3. PAD CONFIGURATIONS

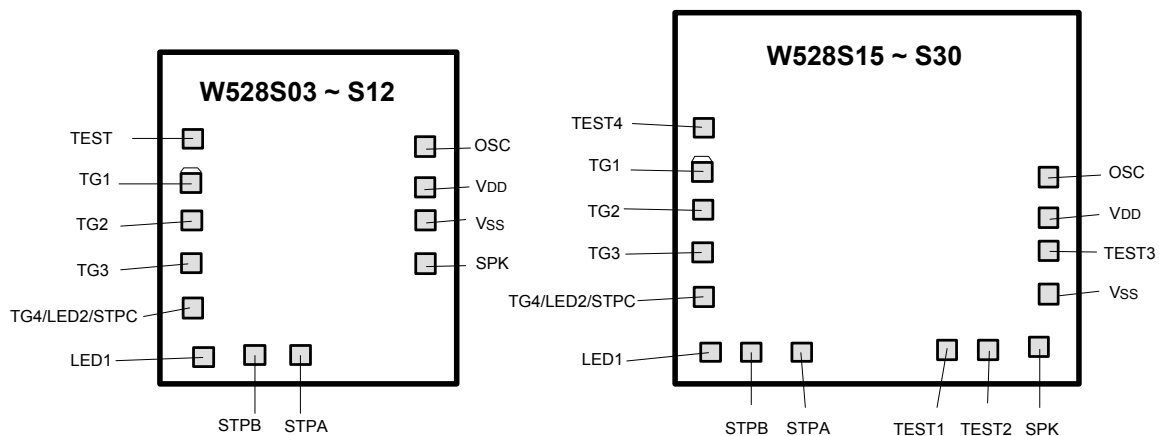

Note: TEST3 is /RESET pin.

4. PAD DESCRIPTION

PAD NAME	I/O	FUNCTION
TG1	I	Trigger Input 1
TG2	I	Trigger Input 2
TG3	I	Trigger Input 3
TG4/LED2/STPC	I/O	Trigger Input 4 or LED 2 or Stop Signal C
LED1	O	LED 1
STPB	O	Stop Signal B
STPA	O	Stop Signal A
SPK	O	Current Output for Speaker
VSS	-	Negative Power Supply
VDD	-	Positive Power Supply
OSC	I	Oscillation Frequency Control
*Test1	-	Test Pin
*Test2	-	Test Pin
*Test3	-	Test Pin or /Reset Pin
Test4	-	Test Pin

* These pads only exist in W528S15 ~ W528S30.

5. BLOCK DIAGRAM

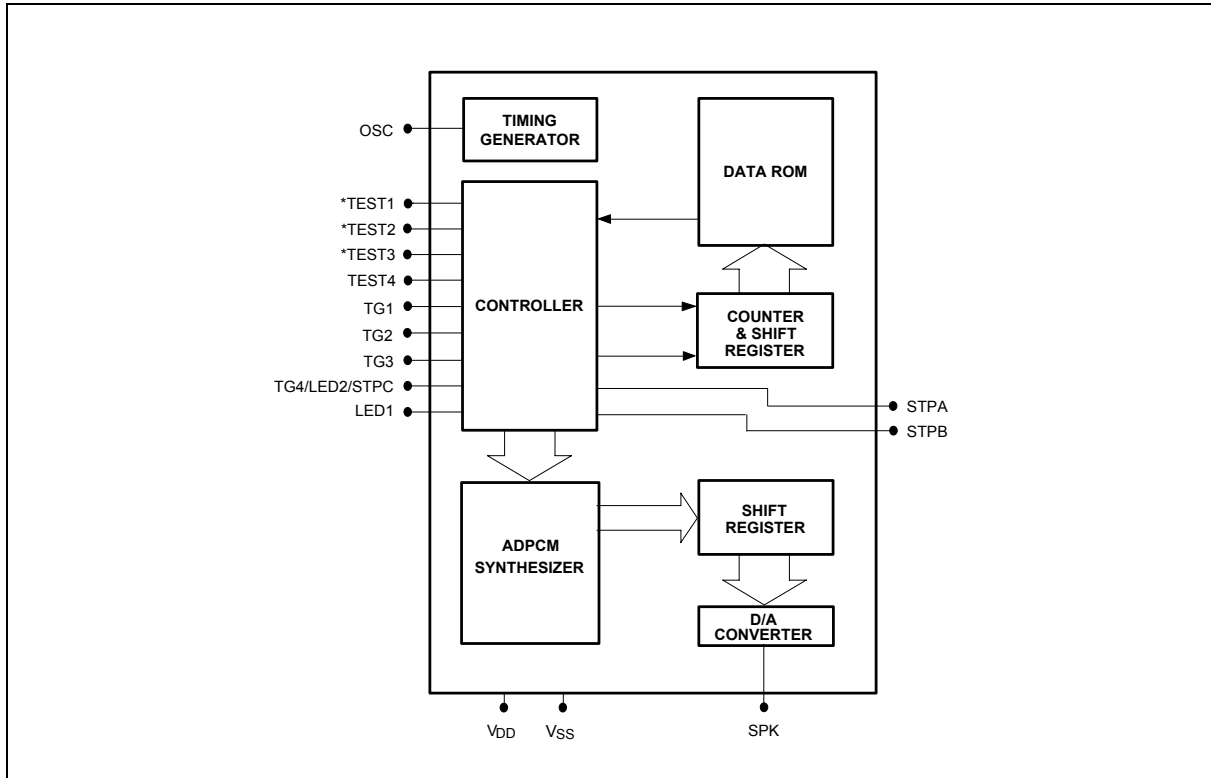

* These pins only exist in W528S15 ~ W528S30.

6. FUNCTIONAL DESCRIPTION

The W528Sxx family provides up to four direct trigger pins, which can be extended to eight or twelve matrix trigger inputs, up to three stop signal output pins, an LED section control, and powerful programmable features. The JUMP and LOAD commands and four programmable registers can be used to program the desired playing mode, stop output signal form, LED flash type, and trigger pin interrupt modes.

The chip's programmable features can also be used to develop new, customized functions for a wide variety of innovative applications.

6.1 Instruction Set Description

This section describes three types of instructions:

- Unconditional instructions, which are executed immediately after they are issued.
- Conditional instructions, which are executed only when the conditions specified in the instructions are satisfied.
- END instruction, which is used to stop all device activity.



Instructions are programmed by writing LOAD and JUMP commands into the R0, EN, STOP, and MODE registers.

Unconditional Instructions:

1. LOAD (LD) Command:

LD R0, value:

This instruction is used to load a voice-group entry value into register R0. The voice-group entry value may range from 0 to 255. The initial value of the R0 register is "00000000."

LD EN, operand:

This instruction is used to define the trigger interrupt settings by loading the operand message into register EN. The initial value of the EN register is "11111111."

- a. The operand is an 8-bit value that can be entered in decimal (default) or hexadecimal (with "0x" as a prefix).
- b. EN is an 8-bit register that is used to enable/disable the rising/falling edge of each of the four trigger inputs.

The 8 bits correspond to the rising/falling edges of the triggers as shown below:

Bit:	7	6	5	4	3	2	1	0
TG:	4R	3R	2R	1R	4F	3F	2F	1F

where "nR/F" represents the rising/falling edge of the n-th trigger pin.

- c. When any one of the eight bits is set to "1" (default), the corresponding trigger will interrupt the current state at the edge indicated. When the bits are set to "0," the triggers will be disabled.
- d. The voice group entry addresses correspond to the interrupt vectors as follows:

TG:	4R	3R	2R	1R	4F	3F	2F	1F
Group:	7	6	5	4	3	2	1	0

EXAMPLE:

The instruction "LD EN, 0x41" is programmed.

EXPLANATION:

- a. "41" is a hexadecimal value equal to the binary value "0100 0001."
- b. These 8 bits of data represent the following trigger interrupt settings:

4R,	3R,	2R,	1R,	4F,	3F,	2F,	1F
0	1	0	0	0	0	0	1

RESULT:

- a. When the rising edge of TG3 (3R) is activated, the EN register will cause TG3 to interrupt the current playing state and jump immediately to voice group 6, the voice group that corresponds to 3R.



- b. When the falling edge of TG1 goes active, the EN register will cause TG1 to interrupt the current playing state and jump immediately to voice group 0, the voice group that corresponds to 1F.
- c. No action will be taken when the other trigger pins are pressed, because the corresponding bits are set to "0."

LD STOP, operand:

This instruction loads the operand message into the STOP register to set the output levels of the stop signals. The initial value of the STOP register is "XXXXX111."

- a. This register is used to program the output levels of the three STOP signals, STPA, STPB, and STPC. Only three of the bits in the register are used, as shown below (an "X" indicates "Don't care"):

Bit:	7	6	5	4	3	2	1	0
Stop:	X	X	X	X	X	STPC	STPB	STPA

- b. When a particular STOP bit is set to "1," The corresponding stop signal will be a high output; when a bit is set to "0," the corresponding stop signal will be a low output.

EXAMPLE:

The instruction "LD STOP, 0x43" is programmed.

EXPLANATION:

- a. "43" is a hexadecimal value equal to a binary value of "0100 0011."
- b. These 8 bits of data represent the following settings:

X,	X,	X,	X,	X,	STPC,	STPB,	STPA
0	1	0	0	0	0	1	1

RESULT:

- a. The STPA and STPB outputs will be high outputs.
- b. The STPC signal will be a low output.
- c. The sixth bit "1" is a "Don't Care" bit and so has no effect on the stop signal output settings.

LD MODE, operand:

This instruction is used to select various operating modes. It loads an operand message into the MODE register to select one mode from each of four pairs of modes, which correspond to bits 4 through 7 of the register (bits 0 to 3 are "Don't Care" bits). The four pairs of modes and the corresponding bits are as follows:

Bit:	7	6	5	4	3	2	1	0
MODE:	Flash/DC	LED2/STPC	TG4/LED2_STPC	45 mS/350 μS	X	X	X	X

A "1" for one of these bits selects the first of the pair of modes indicated; a "0" selects the second of the pair. The initial value of the mode register is "1111XXXX."



EXAMPLE 1:

The four bits are programmed as "1111," so that the eight bits of the register are as follows (an "X" indicates a "Don't Care" bit):

Flash/DC,	LED2/STPC,	TG4/LED2_STPC,	45 mS/350 μ S,	X,	X,	X,	X
1	1	1	1	X	X	X	X

RESULT:

The mode settings are as follows:

- a. Pin 4 (TG4/LED2_STPC) is configured as a trigger pin (TG4), and the LED2/STPC option will be ignored.
- b. The LED is set as a flash type, with a flash frequency of 3 Hz.
- c. The debounce time of the trigger inputs is set to 45 mS.

EXAMPLE 2:

The four bits are programmed as "0000," so that the eight bits of the register are as follows (an "X" indicates a "Don't Care" bit):

Flash/DC,	LED2/STPC,	TG4/LED2_STPC,	45 mS/350 μ S,	X,	X,	X,	X
0	0	0	0	X	X	X	X

RESULT:

The mode settings are as follows:

- a. Pin 4 (TG4/LED2_STPC) is configured as either the LED2 or STPC output (determined by bit 6, LED2/STPC; see next item).
- b. Pin 4 is configured as the STPC output pin.
- c. LED will be lit constantly during operation.
- d. The debounce time of the trigger inputs is set as 350 μ S.

2. JUMP (JP) Command:

JP value: Instructs device to jump directly to the voice group corresponding to the value indicated. The voice group value may range from 0 to 127 (direct jump).

JP R0: Instructs device to jump to whatever voice group is indicated by the value currently stored in register R0, from 0 to 255 (indirect jump).



6.2 Conditional Instructions

Conditional instructions are executed only when the conditions specified in the instructions hold. The conditional instructions are listed below. An explanation of the notation used in the instructions follows.

(Note: There are no conditional instructions for LD MODE.)

- LD R0, VALUE @LAST: VALUE can be set from 0 to 255.
- LD R0, VALUE @TGn_STATUS: VALUE can be set from 0 to 255.
- LD EN, OPERAND @LAST: EN - 4R, 3R, 2R, 1R, 4F, 3F, 2F, 1F.
- LD STOP, OPERAND @LAST: STOP - X, X, X, X, X, STPC, STPB, STPA.
- JP VALUE @LAST: VALUE can be set from 0 to 127.
- JP R0 @LAST
- JP VALUE @TGn_STATUS: VALUE can be set from 0 to 127
- JP R0 @TGn_STATUS

EXPLANATION:

- @LAST: At last time of global repeat.
- @TGn_STATUS: When the status of the trigger specified (TGn) is in the condition specified, where the possible triggers and conditions are the following:

- TG1_HIGH
- TG1_LOW
- TG2_HIGH
- TG2_LOW
- TG3_HIGH
- TG3_LOW
- TG4_HIGH
- TG4_LOW

6.3 End Instruction

END: This command instructs the chip to cease all activity immediately.

6.4 Program Structure Features and Execution Rules

1. There are eight hardware group entry points and 248 software group entry points, as follows:

		Group
8 H/W entries:	TG1F:	0
	TG2F:	1
	TG3F:	2
	TG4F:	3
	TG1R:	4



(Continued)

	TG2R:	5
	TG3R:	6
	TG4R:	7
248 S/W entries:		8
		9
		.
POI:		32
		33
		.
		.
		.
		254
		255

2. Execution begins from group entry and is terminated by END instruction.
3. A H/W trigger interrupt stops the group currently being executed immediately and begins a new group.

6.5 Mask Options

There are four mask options for the W528Sxx family; the mask options are used to select features that cannot be programmed through the chip's registers.

The options are the following:

- LED flash type (synchronous/alternate)
- LED volume-controlled: No/Yes
- LED1 section-controlled: Yes/No
- LED2: section-controlled/STPC-controlled

6.6 Speech Equation Description

The format of the speech equations for the W528Sxx family is shown as below example:

```
GR = N
H4+m1*SOUND1_FL+m2*SOUND2_FL+[1FFFF]+...+T4
END
```

where

- GR = N defines the number of global repeats (from 1 to 16);
- m1 and m2 define the number of local repeats (from 1 to 7);



SOUND1 and SOUND2 are the *.WAM files of ADPCM converted voice data;
 _FL is the section control setting, for which the parameters F and L are as follows:
 F: Voice output frequency setting:
 0 = 4 KHz, 1 = 4.8 KHz, 2 = 6 KHz, 3 = 8 KHz;
 L: LED output setting:
 1: ON
 0: OFF; and
 [1FFFF] is a period of silence of length 1FFFF;
 H4, T4: Represent head and tail ADPCM files, respectively.

6.7 Programmable Power-on Initialization

Whenever the W528Sxx is powered on, the program contained in the 32nd voice group will be executed after the power-on delay (about 160 mS), so the user can write a program into this group to set the power-on initial state. If the user does not wish to execute a program at power-on, an "END" instruction should be entered in group 32. The W528Sxx power-on initialization process can be interrupted by trigger inputs.

6.8 Programming Examples

This section presents several examples of how the functions of the W528Sxx may be programmed. Customer programs should be written in ASCII code using a text editor; after compiling, the sound effects resulting from the programs can be tested using a Winbond demo board.

EXAMPLE1: Four playing mode settings:

a. One-Shot Trigger Mode

```
0: LD EN, 0x01          ; Enable TG1 falling edge input only.
  H4 + sound1 + T4
  END
```

The timing diagram for this example is shown below:

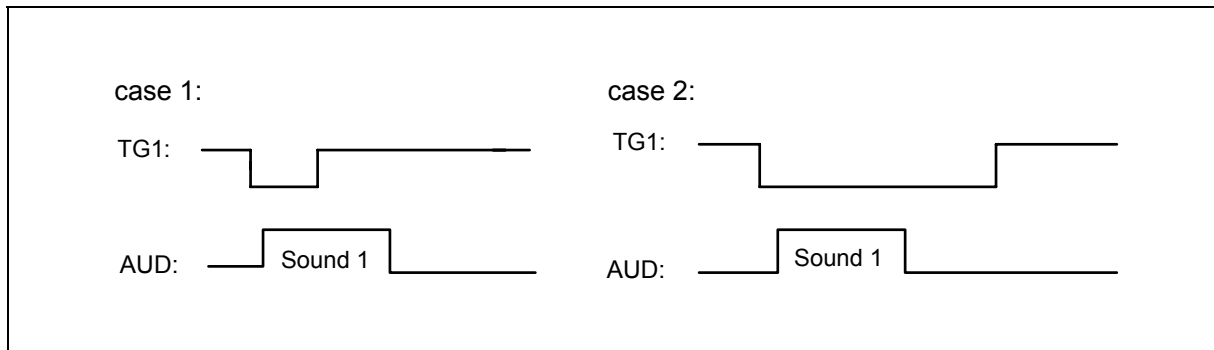



- b. Level-Hold Trigger Mode
- 0: LD EN, 0x11 ; Enable TG1 rising/falling edge input.
- H4 + sound1 + T4
- JP 0 ; Repeat sound1 until TG1 key released.
- 4: END ; As soon as TG1 key is released, execute this group entry.

The timing diagram is shown below:

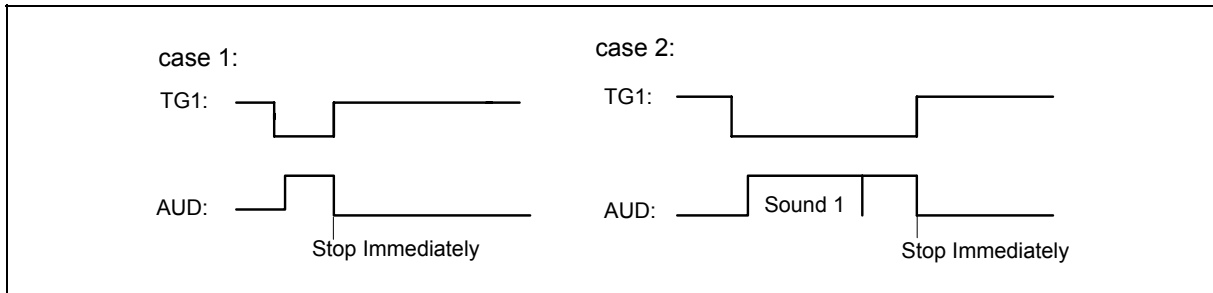

- c. Complete-Cycle Level Hold
- 0: LD EN, 0x01 ; Enable TG1 falling edge only.
- H4 + sound1 + T4
- JP 0 @TG1_LOW ; If TG1 status is low level voltage (trigger is pressed), then j ump to 0;
- if not, execute next instruction (END).
- END

The timing diagram is shown below:

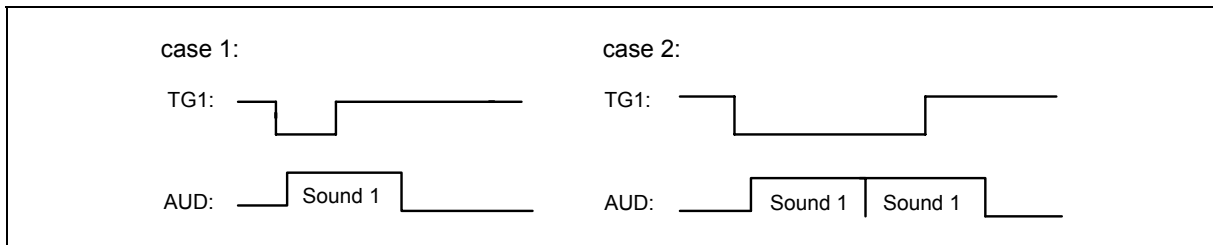

- d. Single-Cycle Level Hold
- 0: LD EN, 0x11 ; Enable both falling and rising edge input of TG1.
- H4 + sound1 + T4
- END
- :
- :
- :
- 4: END ; As soon as TG1 is key released, execute this group entry.



The timing diagram is shown below:

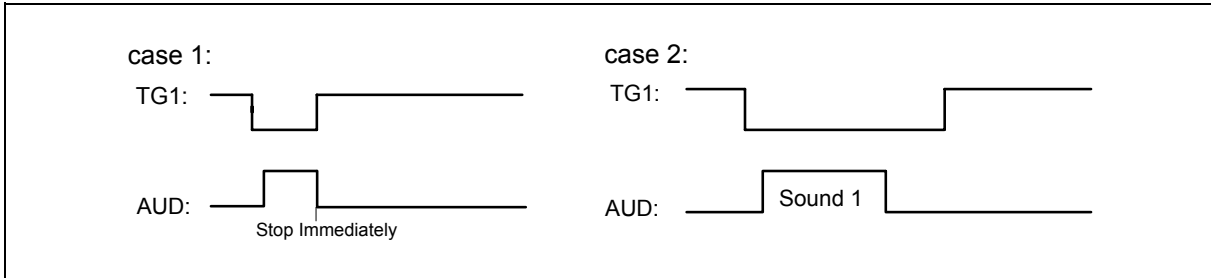

EXAMPLE 2: Retriggerable and Non-retriggerable setting

a. Retriggerable:

```

0: LD EN, 0x01      ; 0x01 = 00000001B, only TG1 falling edge interrupt is enabled.
  END
.
.
.
  END
    
```

The timing diagram is shown below:

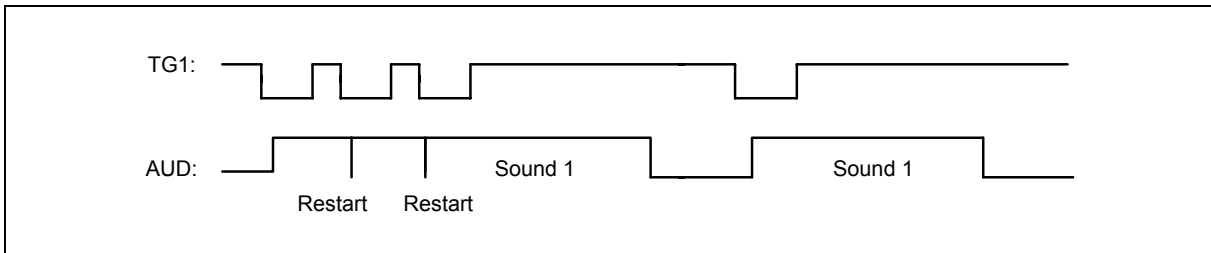

b. Non-retriggerable:

```

0: LD EN, 0x00      ; 0x00 = 00000000B, TG1 falling edge interrupt is disabled.
.
.
LD EN, 0x11        ; Recover the TG1 falling and rising edge interrupt is enabled.
  END
    
```

The timing diagram is shown below:

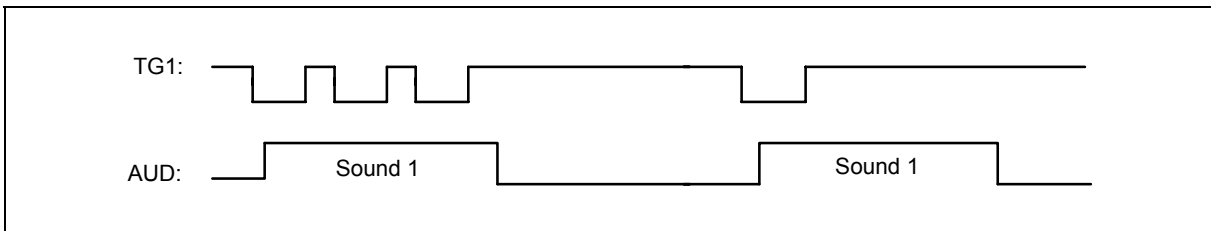



7. ELECTRICAL CHARACTERISTICS

7.1 Absolute Maximum Ratings

PARAMETER	SYMBOL	CONDITIONS	RATED VALUE	UNIT
Power Supply	VDD-VSS	-	-0.3 to +7.0	V
Input Voltage	VIN	All Inputs	VSS -0.3 to VDD +0.3	V
Storage Temp.	TSTG	-	-55 to +150	°C
Operating Temp.	TOPR	-	0 to +70	°C

Note: Exposure to conditions beyond those listed under Absolute Maximum Ratings may adversely affect the life and reliability of the device.

7.2 DC Characteristics

(TA = 25° C, VSS = 0 V)

PARAMETER	SYM.	CONDITIONS	LIMITS			UNIT	
			MIN.	TYP.	MAX.		
Operating Voltage	VDD	-	2.4	3	5.5	V	
Input Voltage	VIL	All Input Pins	VSS -0.3	-	0.3 VDD	V	
	VIH		0.7 VDD	-	VDD		
Standby Current	IDD1	VDD = 3V, No Playing	-	-	0.2	μA	
	IDD2	VDD = 5V, No Playing	-	-	0.4		
Operating Current	IOP1	VDD = 3V, No Load	-	-	400	μA	
	IOP2	VDD = 5V, No Load	-	-	800		
Input Current for TG1-TG4	IIN	VDD = 3V, VIN = 0V	-	-	6	μA	
SPK (D/A Full Scale)	IO1	VDD = 4.5V, RL = 100 Ω	-4.0	-5.0	-6.0	mA	
Output Current of STPC	IO1	VDD = 3V, VOUT = 0.4V	1	-	-	mA	
	IOH	VDD = 3V, VOUT = 2.7V	-0.5	-	-		
Output Current	LED1 LED2	IO	VDD = 3V, VOUT = 1V	10	-	mA	
		IO	VDD = 4.5V, VOUT = 1V	15	-		
	STPA STPB	IO1	VDD = 3V, VOUT = 0.4V	1	3		-
		IOH	VDD = 3V, VOUT = 2.7V	-1	-3		-
Oscillation Freq.	FOSC	VDD = 3V, ROSC = Typ.	2.7	3	3.3	MHz	
		VDD = 4.5V, ROSC = Typ.	2.7	3	3.3		
Oscillation Freq. Deviation by Voltage Drop	$\frac{\Delta F_{OSC}}{F_{OSC}}$	$\frac{F(3V) - F(2.4)}{F(3V)}$	0	4	7.5	%	
Input Debounce Time	TDEB1	FOSC = 3 MHz, SR = 6 KHz	45	-	-	mS	
	TDEB2		350	-	-	μS	

Note: Rosc = 430KOhm for all items in W528Sxx

8. APPLICATION CIRCUIT

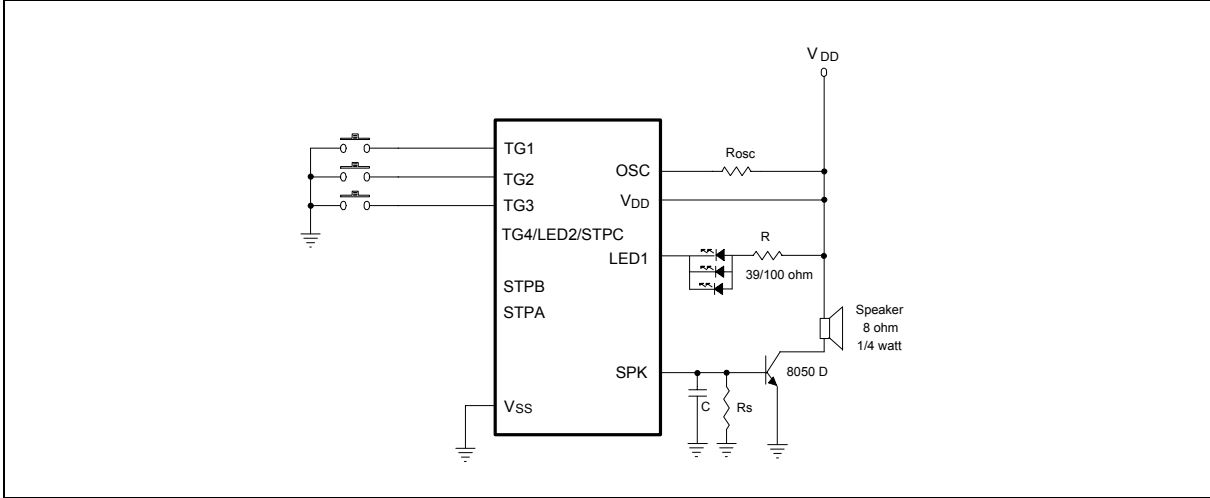

Notes:

1. In principle, the playing speed determined by ROSC should correspond to the sampling rate during the coding phase. The playing speed may be adjusted by varying ROSC, however.
2. Rs is an optional current-dividing resistor. If Rs is added, the resistance should be between 470 and 750Ω.
3. Cs is optional.
4. The DC current gain β of transistor 8050 ranges from 120 to 200.
5. All unused trigger pins can be left open because of their internal pull-high resistance.
6. R is used to limit the current on the LED. Case 1: $V_{DD} = 3V$, $R = 39\Omega$ for 1/2/3 LEDs.
Case 2: $V_{DD} = 4.5V$, $R = 39\Omega$ for 2/3 LEDs and $R = 100\Omega$ for 1 LED.
7. No warranty for production.

8.1 Supplement

A. Power Bouncing

If an irregularity (such as bouncing) occurs in the power supply to V_{DD} , as shown in the diagram, the W528Sxx may hang or the logic state machine may lock up. To return the chip to normal operation, short V_{DD} and V_{SS} for the W528Sxx and then release again.

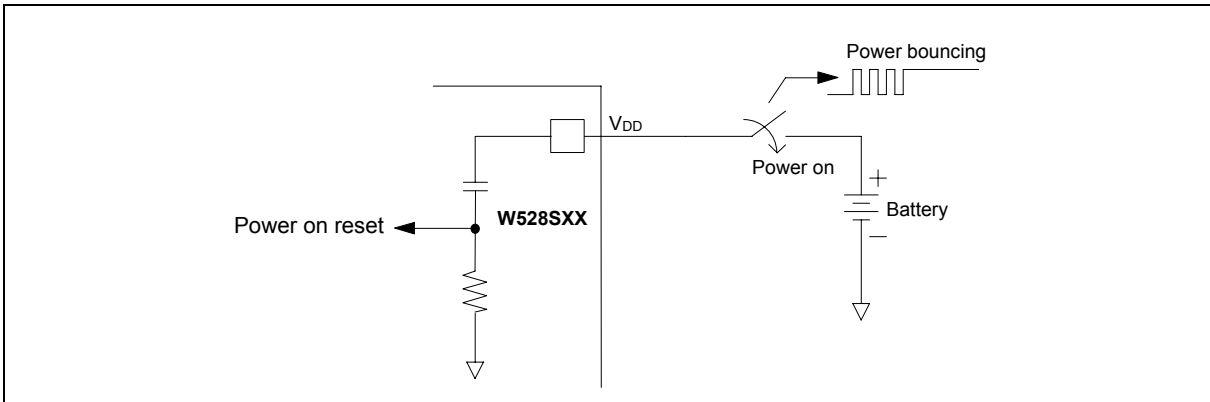

B. Trigger Pin Coupling Effect

The trigger pins (TG1–TG4) are built-in 500K Ω pull high resistor.

If the wire of the input trigger is very close to the speaker wire in the application environment, the coupling effect will occur. The input voltage of the trigger pin will be unstable, causing the trigger operation to become abnormal.

An external pull high resistor (R_i) connecting the trigger pin and VDD can resolve this problem. The value of the R_i depends on your application environment.

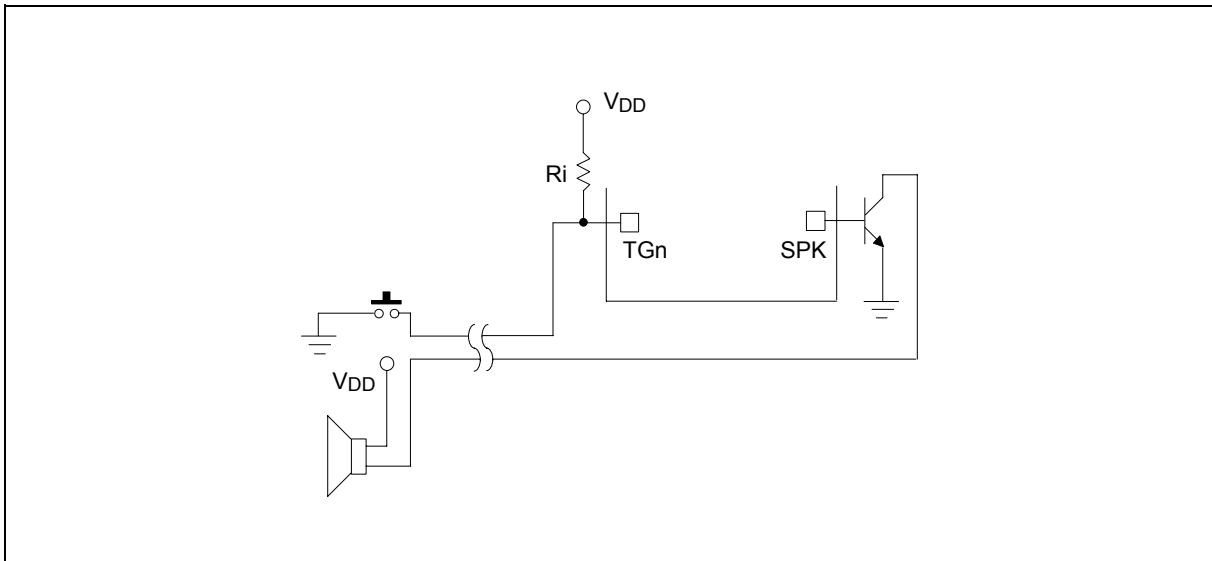



9. REVISION HISTORY

REVISION	DATE	MODIFICATIONS
A1	Mar. 1999	Preliminary release.
A2	June 13, 2003	In DC spec., modify minimum input debounce time as 45 mS and 350 μ S.



Headquarters
 No. 4, Creation Rd. III,
 Science-Based Industrial Park,
 Hsinchu, Taiwan
 TEL: 886-3-5770066
 FAX: 886-3-5665577
<http://www.winbond.com.tw/>

Taipei Office
 9F, No.480, Rueiguang Rd.,
 Neihu District, Taipei, 114,
 Taiwan, R.O.C.
 TEL: 886-2-8177-7168
 FAX: 886-2-8751-3579

Winbond Electronics Corporation America
 2727 North First Street, San Jose,
 CA 95134, U.S.A.
 TEL: 1-408-9436666
 FAX: 1-408-5441798

Winbond Electronics Corporation Japan
 7F Daini-ueno BLDG, 3-7-18
 Shinyokohama Kohoku-ku,
 Yokohama, 222-0033
 TEL: 81-45-4781881
 FAX: 81-45-4781800

Winbond Electronics (Shanghai) Ltd.
 27F, 2299 Yan An W. Rd. Shanghai,
 200336 China
 TEL: 86-21-62365999
 FAX: 86-21-62365998

Winbond Electronics (H.K.) Ltd.
 Unit 9-15, 22F, Millennium City,
 No. 378 Kwun Tong Rd.,
 Kowloon, Hong Kong
 TEL: 852-27513100
 FAX: 852-27552064

*Please note that all data and specifications are subject to change without notice.
 All the trade marks of products and companies mentioned in this data sheet belong to their respective owners.*