



8-BIT MICROCONTROLLER

GENERAL DESCRIPTION

The W78L801 is an 8-bit microcontroller which can accommodate a wide range of supply voltages with low power consumption. The instruction set for the W78L801 is fully compatible with the standard 8051. The W78L801 contains an 4K bytes Mask ROM; a 256 bytes RAM; four 8-bit bi-directional and bit-addressable I/O ports; an additional 6-bit I/O port P4; two 16-bit timer/counters; a hardware watchdog timer. These peripherals are supported by a twelve sources two-level interrupt capability. The W78L801 does not contain serial port.

The W78L801 microcontroller has two power reduction modes, idle mode and power-down mode, both of which are software selectable. The idle mode turns off the processor clock but allows for continued peripheral operation. The power-down mode stops the crystal oscillator for minimum power consumption. The external clock can be stopped at any time and in any state without affecting the processor.

FEATURES

- Fully static design 8-bit CMOS microcontroller
- Wide supply voltage of 1.8V to 5.5V
- DC-24 MHz operation
- 256 bytes of on-chip scratchpad RAM
- 4 KB Mask-ROM
- 64 KB program memory address space
- 64 KB data memory address space
- Four 8-bit bi-directional ports
- Two 16-bit timer/counters
- Watchdog Timer
- Direct LED drive outputs
- Twelve sources, two-level interrupt capability
- Wake-up via external interrupts at Port 1
- EMI reduction mode
- Built-in power management
- Code protection mechanism
- Packages:
 - DIP 40: W78L801-24
 - PLCC 44: W78L801P-24
 - PQFP 44: W78L801F-24

PIN CONFIGURATIONS

40-Pin DIP (W78L801)

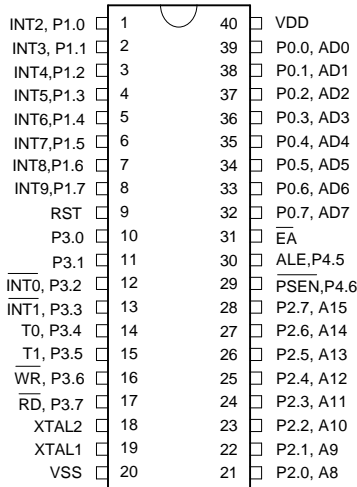

44-Pin PLCC (W78L801P)

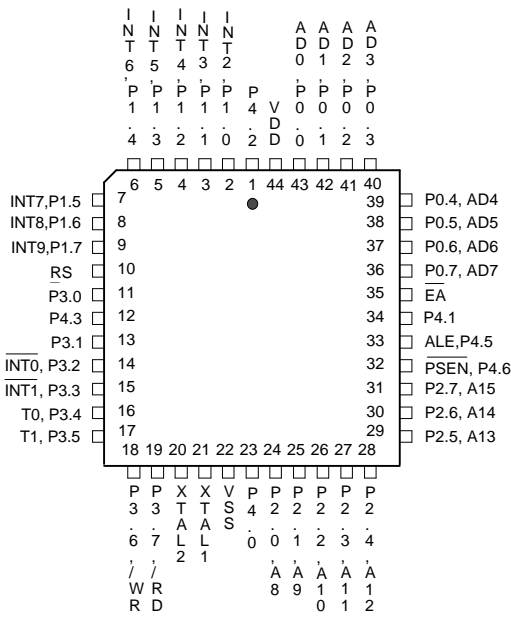

44-Pin QFP (W78L801F)

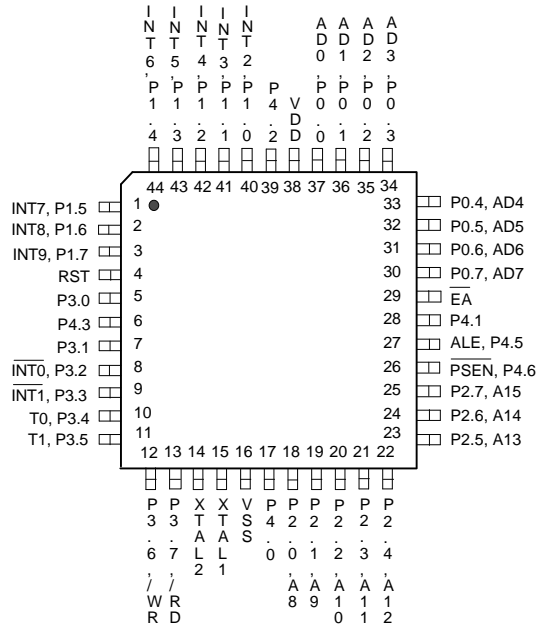

PIN DESCRIPTION

SYMBOL	DESCRIPTIONS
\overline{EA}	EXTERNAL ACCESS ENABLE: This pin forces the processor to execute out of external ROM. It should be kept high to access internal ROM. The ROM address and data will not be presented on the bus if \overline{EA} pin is high and the program counter is within on-chip ROM area. Otherwise they will be presented on the bus.
\overline{PSEN}	PROGRAM STORE ENABLE: \overline{PSEN} enables the external ROM data onto the Port 0 address/ data bus during fetch and MOV _C operations. When internal ROM access is performed, no \overline{PSEN} strobe signal outputs from this pin. This pin also serves the alternative function P4.6.
ALE	ADDRESS LATCH ENABLE: ALE is used to enable the address latch that separates the address from the data on Port 0. This pin also serves the alternative function P4.5
RST	RESET: A high on this pin for two machine cycles while the oscillator is running resets the device.
XTAL1	CRYSTAL1: This is the crystal oscillator input. This pin may be driven by an external clock.
XTAL2	CRYSTAL2: This is the crystal oscillator output. It is the inversion of XTAL1.
V _{SS}	GROUND: Ground potential
V _{DD}	POWER SUPPLY: Supply voltage for operation.
P0.0–P0.7	PORT 0: Port 0 is a bi-directional I/O port which also provides a multiplexed low order address/data bus during accesses to external memory. The pins of Port 0 can be individually configured to open-drain or standard port with internal pull-ups.
P1.0–P1.7	PORT 1: Port 1 is a bi-directional I/O port with internal pull-ups. The bits have alternate functions which are described below: INT2–INT9(P1.0–P1.7): External interrupt 2 to 9
P2.0–P2.7	PORT 2: Port 2 is a bi-directional I/O port with internal pull-ups. This port also provides the upper address bits for accesses to external memory.
P3.0–P3.7	PORT 3: Port 3 is a bi-directional I/O port with internal pull-ups. The pins P3.4 to P3.7 can be configured with high sink current which can drive LED displays directly. All bits have alternate functions, which are described below: $\overline{INT0}$ (P3.2) : External Interrupt 0 $\overline{INT1}$ (P3.3) : External Interrupt 1 T0(P3.4) : Timer 0 External Input T1(P3.5) : Timer 1 External Input \overline{WR} (P3.6) : External Data Memory Write Strobe \overline{RD} (P3.7) : External Data Memory Read Strobe
P4.0–P4.6	PORT 4: A 6-bit bi-directional I/O port which is bit-addressable. Pins P4.0 to P4.3 are available on 44-pin PLCC/QFP package. Pins P4.5 and P4.6 are the alternative function corresponding to ALE and \overline{PSEN} .

BLOCK DIAGRAM

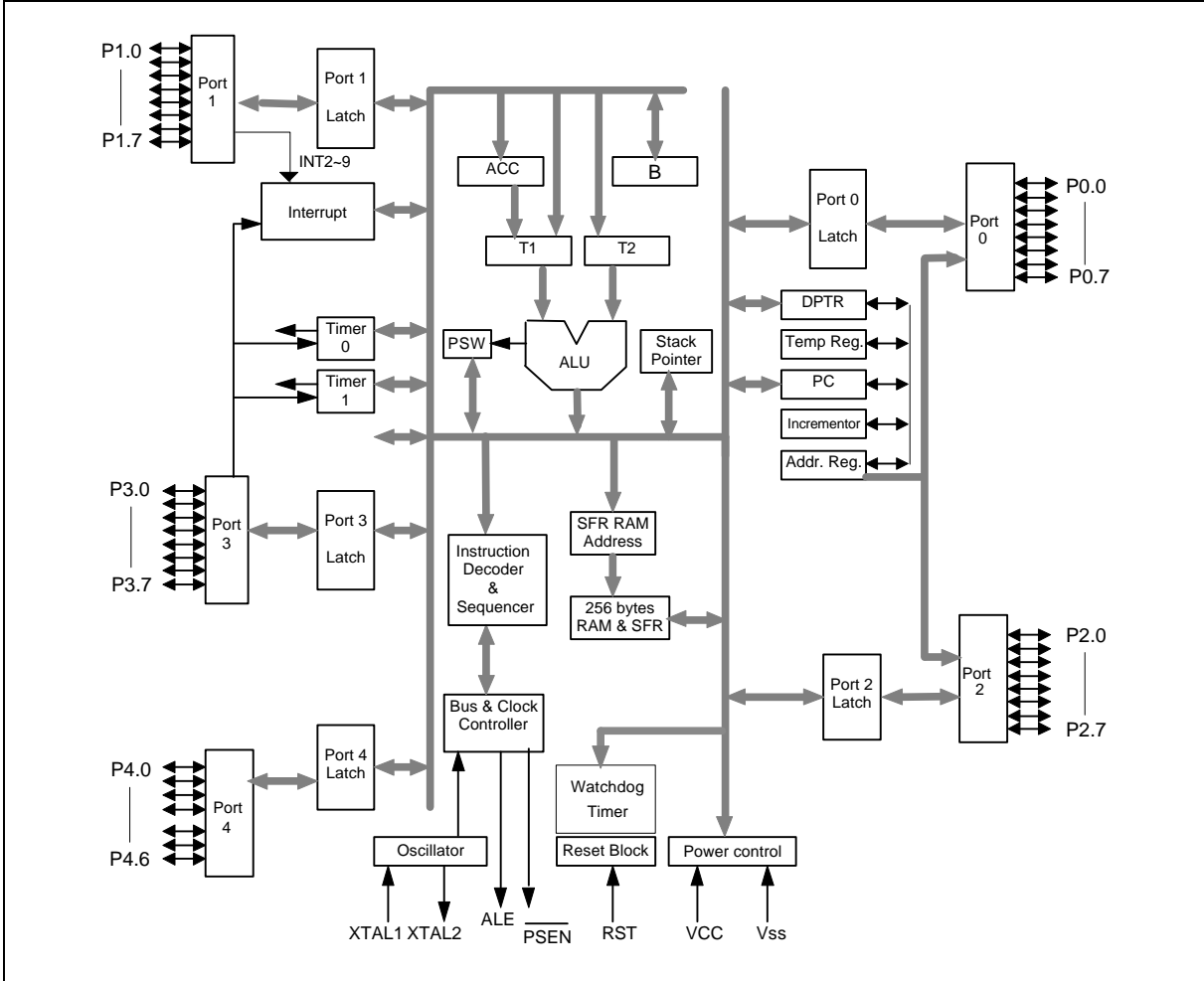

FUNCTIONAL DESCRIPTION

The W78L801 architecture consists of a core controller surrounded by various registers, five general purpose I/O ports, 256 bytes of RAM, two timer/counters. The processor supports 111 different opcodes and references both a 64K program address space and a 64K data storage space.

Timers 0, 1

Timers 0, 1 each consist of two 8-bit data registers. These are called TL0 and TH0 for Timer 0, TL1 and TH1 for Timer 1. The TCON and TMOD registers provide control functions for timers 0 and 1. The operations of Timer 0 and Timer 1 are the same as in the W78C51.

I/O Port Options

The Port 0 and Port 3 of W78L801 may be configured with different types by setting the bits of the Port Options Register POR that is located at 86H. The pins of Port 0 can be configured with either the open drain or standard port with internal pull-up. By the default, Port 0 is an open drain bi-directional



I/O port. When the PUP bit in the POR register is set, the pins of Port 0 will perform a quasi-bi-directional I/O port with internal pull-up that is structurally the same as Port 2. The high nibble of Port 3 (P3.4 to P3.7) can be selected to serve the direct LED displays drive outputs by setting the HDx bit in the PO register. When the HDx bit is set, the corresponding pin P3.x can sink about 20mA current for driving LED display directly. After reset, the POR register is cleared and the pins of Ports 0 and 3 are the same as those of the standard 80C31. The POR register is shown below.

Port Options Register

Bit:	7	6	5	4	3	2	1	0
	EP6	EP5	-	HD7	HD6	HD5	HD4	PUP
	Mnemonic: POR			Address: 86H				

PUP : Enable Port 0 weak pull-up.

HD4-7: Enable pins P3.4 to P3.7 individually with High Drive outputs.

EP5 : Enable P4.5. To set this bit shifts $\overline{\text{ALE}}$ pin to the alternate function P4.5.

EP6 : Enable P4.6. To set this bit shifts $\overline{\text{PSEN}}$ pin to the alternate function P4.6

Port 4

The W78L801 has one additional bit-addressable I/O port P4 in which the port address is D8H. The Port 4 contains seven bits; P4.0 to P4.3 are only available on 44-pin PLCC/QFP package; P4.5 and P4.6 are the alternate function corresponding to pins $\overline{\text{ALE}}$, $\overline{\text{PSEN}}$. When program is running in the internal memory without any access to external memory, $\overline{\text{ALE}}$ and $\overline{\text{PSEN}}$ may be individually configured to the alternate functions P4.5 and P4.6 that serve as general purpose I/O pins. To enable I/O port P4.5 and P4.6, the bits EP5 and EP6 in the POR register must be set. During reset, the $\overline{\text{ALE}}$ and $\overline{\text{PSEN}}$ perform as in the standard 80C32. The alternate functions P4.5 and P4.6 must be enabled by software. Care must be taken with the $\overline{\text{ALE}}$ pins when configured as the alternate functions. The $\overline{\text{ALE}}$ will emit pulses until either the EP5 bit in POR register or AO bit in AUXR register is set to 1. i.e. User's applications should elude the $\overline{\text{ALE}}$ pulses before software configure it with I/O port P4.5.

Port 4

Bit:	7	6	5	4	3	2	1	0
	-	P4.6	P4.5	-	P4.3	P4.2	P4.1	P4.0
	Mnemonic: P4			Address: D8H				

Interrupt System

The W78L801 has twelve interrupt sources: $\overline{\text{INT0}}$ and $\overline{\text{INT1}}$; Timer 0,1; INT2 to INT9. Each interrupt vectors to a specific location in program memory for its interrupt service routine. Each of these sources can be individually enabled or disabled by setting or clearing the corresponding bit in Special Function Register IE0 and IE1. The individual interrupt priority level depends on the Interrupt Priority Register IP0 and IP1. Additional external interrupts INT2 to INT9 are level sensitive and may be used to awake the device from power down mode. The Port 1 interrupts can be initialized to either active HIGH or LOW via setting the Interrupt Polarity Register IX. The IRQ register contains the flags of Port



1 interrupts. Each flag in IRQ register will be set when an interrupt request is recognized but *must be cleared by software*. Note that the interrupt flags have to be cleared before the interrupt service routine is completed, or else another interrupt will be generated.

Interrupt Enable Register 0

Bit:	7	6	5	4	3	2	1	0
	EA	-	-	-	ET1	EX1	ET0	EX0
	Mnemonic: IE				Address: A8H			

- EA : Global enable. Enable/disable all interrupts.
- ET1: Enable Timer 1 interrupt
- EX1: Enable external interrupt 1
- ET0: Enable Timer 0 interrupt
- EX0: Enable external interrupt 0

Interrupt Enable Register 1

Bit:	7	6	5	4	3	2	1	0
	EX9	EX8	EX7	EX6	EX5	EX4	EX3	EX2
	Mnemonic: IE1				Address: E8H			

- EX9: Enable external interrupt 9
 - EX8: Enable external interrupt 8
 - EX7: Enable external interrupt 7
 - EX6: Enable external interrupt 6
 - EX5: Enable external interrupt 5
 - EX4: Enable external interrupt 4
 - EX3: Enable external interrupt 3
 - EX2: Enable external interrupt 2
- Note: 0 = interrupt disabled, 1 = interrupt enabled.

Interrupt Priority Register 0

Bit:	7	6	5	4	3	2	1	0
	-	PS1	PT2	PS	PT1	PX1	PT0	PX0
	Mnemonic: IP0				Address: B8h			

- IP.7: Unused.
- PS1: This bit defines the Serial port 1 interrupt priority. PS = 1 sets it to higher priority level.
- PT2: This bit defines the Timer 2 interrupt priority. PT2 = 1 sets it to higher priority level.
- PS : This bit defines the Serial port 0 interrupt priority. PS = 1 sets it to higher priority level.
- PT1: This bit defines the Timer 1 interrupt priority. PT1 = 1 sets it to higher priority level.
- PX1: This bit defines the External interrupt 1 priority. PX1 = 1 sets it to higher priority level.
- PT0: This bit defines the Timer 0 interrupt priority. PT0 = 1 sets it to higher priority level.
- PX0: This bit defines the External interrupt 0 priority. PX0 = 1 sets it to higher priority level.



Interrupt Priority Register 1

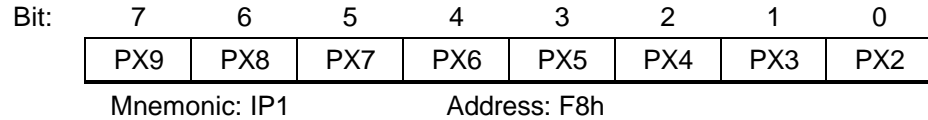

- PX9: This bit defines the External interrupt 9 priority. PX9 = 1 sets it to higher priority level.
- PX8: This bit defines the External interrupt 8 priority. PX8 = 1 sets it to higher priority level.
- PX7: This bit defines the External interrupt 7 priority. PX7 = 1 sets it to higher priority level.
- PX6: This bit defines the External interrupt 6 priority. PX6 = 1 sets it to higher priority level.
- PX5: This bit defines the External interrupt 5 priority. PX5 = 1 sets it to higher priority level.
- PX4: This bit defines the External interrupt 4 priority. PX4 = 1 sets it to higher priority level.
- PX3: This bit defines the External interrupt 3 priority. PX3 = 1 sets it to higher priority level.
- PX2: This bit defines the External interrupt 2 priority. PX2 = 1 sets it to higher priority level.

Interrupt Polarity Register

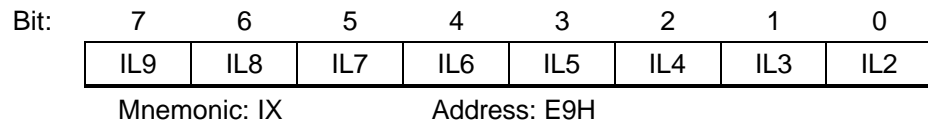

- IL9: External interrupt 9 polarity level.
- IL8: External interrupt 8 polarity level.
- IL7: External interrupt 7 polarity level.
- IL6: External interrupt 6 polarity level.
- IL5: External interrupt 5 polarity level.
- IL4: External interrupt 4 polarity level.
- IL3: External interrupt 3 polarity level.
- IL2: External interrupt 2 polarity level.

Note: 0 = active LOW, 1 = active HIGH.

Interrupt Request Flag Register

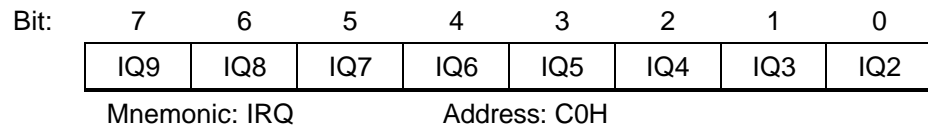

- IQ9: External interrupt 9 request flag.
- IQ8: External interrupt 8 request flag.
- IQ7: External interrupt 7 request flag.
- IQ6: External interrupt 6 request flag.
- IQ5: External interrupt 5 request flag.
- IQ4: External interrupt 4 request flag.
- IQ3: External interrupt 3 request flag.
- IQ2: External interrupt 2 request flag.



Table.1 Priority level for simultaneous requests of the same priority interrupt sources

SOURCE	FLAG	PRIORITY LEVEL	VECTOR ADDRESS
External Interrupt 0	IE0	(highest)	0003H
External Interrupt 5	IQ5		0053H
Timer 0 Overflow	TF0		000BH
External Interrupt 6	IQ6		005BH
External Interrupt 1	IE1		0013H
External Interrupt 2	IQ2		003BH
External Interrupt 7	IQ7		0063H
Timer 1 Overflow	TF1		001BH
External Interrupt 3	IQ3		0043H
External Interrupt 8	IQ8		006BH
External Interrupt 4	IQ4		004BH
External Interrupt 9	IQ9	(lowest)	0073H

Watchdog Timer

The Watchdog timer is a free-running timer which can be programmed by the user to serve as a system monitor, a time-base generator or an event timer. It is basically a set of dividers that divide the system clock. The divider output is selectable and determines the time-out interval. When the time-out occurs, a system reset can be caused if it is enabled. The main use of the Watchdog timer is as a system monitor. This is important in real-time control applications. In case of power glitches or electro-magnetic interference, the processor may begin to execute errant code. If this is left unchecked the entire system may crash. The watchdog time-out selection will result in different time-out values depending on the clock speed. The Watchdog timer will be disabled on reset. In general, software should restart the Watchdog timer to put it into a known state. The control bits that support the Watchdog timer are discussed below.

Watchdog Timer Control Register

Bit:	7	6	5	4	3	2	1	0
	ENW	CLRW	WIDL	-	-	PS2	PS1	PS0
	Mnemonic: WDTC			Address: 8FH				

ENW : Enable watch-dog if set.

CLRW : Clear watch-dog timer and prescaler if set. This flag will be cleared automatically

WIDL : If this bit is set, watch-dog is enabled under IDLE mode. If cleared, watch-dog is disabled under IDLE mode. Default is cleared.

PS2, PS1, PS0 : Watch-dog prescaler timer select. Prescaler is selected when set PS2-0 as follows:

PS2	PS1	PS0	PRESCALER SELECT
0	0	0	2
0	1	0	4

Continued

PS2	PS1	PS0	PRESCALER SELECT
0	0	1	8
0	1	1	16
1	0	0	32
1	0	1	64
1	1	0	128
1	1	1	256

The time-out period is obtained using the following formula:

$$\frac{1}{\text{OSC}} \times 2^{14} \times \text{PRESCALER} \times 1000 \times 12 \text{ mS}$$

Before Watchdog time-out occurs, the program must clear the 14-bit timer by writing 1 to WDTC.6 (CLRW). After 1 is written to this bit, the 14-bit timer, prescaler and this bit will be reset on the next instruction cycle. The Watchdog timer is cleared on reset.

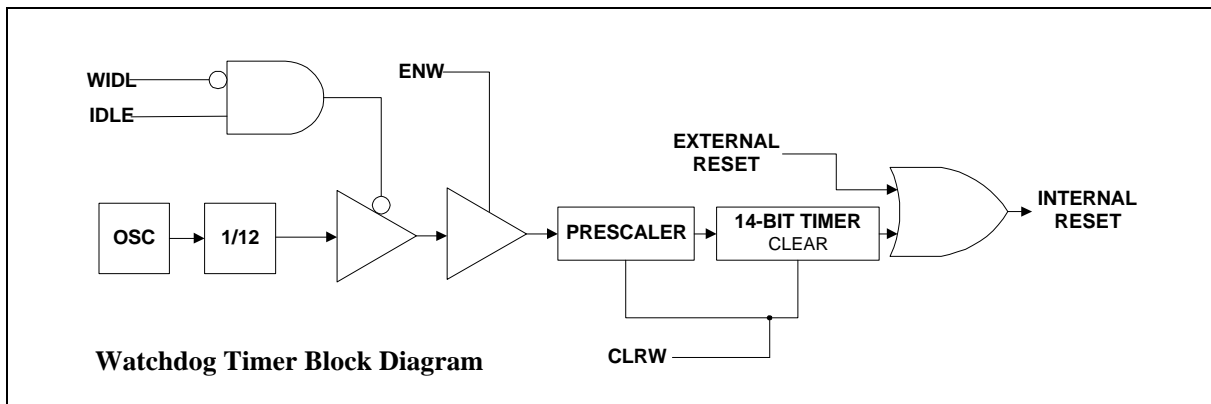

Typical Watch-Dog time-out period when OSC = 20 MHz

PS2	PS1	PS0	WATCHDOG TIME-OUT PERIOD
0	0	0	19.66 mS
0	1	0	39.32 mS
0	0	1	78.64 mS
0	1	1	157.28 mS
1	0	0	314.57 mS
1	0	1	629.14 mS
1	1	0	1.25 S
1	1	1	2.50 S



Clock

The W78L801 is designed to be used with either a crystal oscillator or an external clock. Internally, the clock is divided by two before it is used. This makes the W78L801 relatively insensitive to duty cycle variations in the clock. The W78L801 incorporates a built-in crystal oscillator. To make the oscillator work, a crystal must be connected across pins XTAL1 and XTAL2. In addition, a load capacitor must be connected from each pin to ground. An external clock source should be connected to pin XTAL1. Pin XTAL2 should be left unconnected. The XTAL1 input is a CMOS-type input, as required by the crystal oscillator.

Power Management

Idle Mode

The idle mode is entered by setting the IDL bit in the PCON register. In the idle mode, the internal clock to the processor is stopped. The peripherals and the interrupt logic continue to be clocked. The processor will exit idle mode when either an interrupt or a reset occurs.

Power-down Mode

When the PD bit in the PCON register is set, the processor enters the power-down mode. In this mode all of the clocks are stopped, including the oscillator. To exit from power-down mode is by a hardware reset or external interrupts INT2 to INT9 when enabled.

AUXR - Auxiliary Register

Bit:	7	6	5	4	3	2	1	0
	-	-	-	-	-	-	-	AO

Mnemonic: AUXR

Address: 8Eh

AO: Turn off ALE signal.

Reduce EMI Emission

Because of the on-chip ROM, when a program is running in internal ROM space, the ALE will be unused. The transition of ALE will cause noise, so it can be turned off to reduce the EMI emission if it is not needed. Turning off the ALE signal transition only requires setting the bit 0 of the AUXR SFR, which is located at 08Eh. When ALE is turned off, it will be reactivated when the program accesses external ROM/RAM data or jumps to execute an external ROM code. The ALE signal will turn off again after it has been completely accessed or the program returns to internal ROM code space.

Reset

The external RESET signal is sampled at S5P2. To take effect, it must be held high for at least two machine cycles while the oscillator is running. An internal trigger circuit in the reset line is used to deglitch the reset line when the W78L801 is used with an external RC network. The reset logic also has a special glitch removal circuit that ignores glitches on the reset line.

During reset, the ports are initialized to FFH, the stack pointer to 07H, PCON (with the exception of bit 4) to 00H, and all of the other SFR registers except SBUF to 00H. SBUF is not reset.



ABSOLUTE MAXIMUM RATINGS

PARAMETER	SYMBOL	MIN.	MAX.	UNIT
DC Power Supply	V _{DD} -V _{SS}	-0.3	+6.0	V
Input Voltage	V _{IN}	V _{SS} -0.3	V _{DD} +0.3	V
Operating Temperature	T _A	0	70	°C
Storage Temperature	T _{ST}	-55	+150	°C

Note: Exposure to conditions beyond those listed under Absolute Maximum Ratings may adversely affect the life and reliability of the device.

DC CHARACTERISTICS

V_{SS} = 0V ; T_A = 25° C; unless otherwise specified.

PARAMETER	SYM.	SPECIFICATION			TEST CONDITIONS
		MIN.	MAX.	UNIT	
Operating Voltage	V _{DD}	2.2	5.5	V	
Operating Current	I _{DD}	-	20	mA	V _{DD} = 5.5V, 16 MHz, no load, RST = 1
		-	3	mA	V _{DD} = 2.2V, 16 MHz, no load, RST = 1
Idle Current	I _{IDLE}	-	6	mA	V _{DD} = 5.5V, 16 MHz, no load
		-	1.5	mA	V _{DD} = 2.2V, 16 MHz, no load
Power Down Current	I _{PWDN}	-	50	μA	V _{DD} = 5.5V, no load
		-	30	μA	V _{DD} = 2.2V, no load
Input					
Input Current P1, P2, P3, P4	I _{IN}	-50	+10	μA	V _{DD} = 5.5V V _{IN} = 0V or V _{DD}
Input Current RST	I _{IN2}	-60	+300	μA	V _{DD} = 5.5V 0 < V _{IN} < V _{DD}
Input Leakage Current P0, \overline{EA}	I _{LK1}	-10	+10	μA	V _{DD} = 5.5V 0V < V _{IN} < V _{DD}
Logic 1-to-0 Transition Current P1, P2, P3, P4	I _{TL}	-500	-200	μA	V _{DD} = 5.5V V _{IN} = 2V

DC Characteristics, continued

PARAMETER	SYM.	SPECIFICATION			TEST CONDITIONS
		MIN.	MAX.	UNIT	
Input Low Voltage P1, P2, P3, P4, \overline{EA}	VIL1	0	0.8	V	VDD = 5.5V
		0	0.5	V	VDD = 2.2V
Input Low Voltage RST ^[*3]	VIL2	0	0.8	V	VDD = 5.5V
		0	0.3	V	VDD = 2.2V
Input Low Voltage XTAL1 ^[*3]	VIL3	0	0.8		VDD = 5.5V
		0	0.6	V	VDD = 2.2V
Input High Voltage P1, P2, P3, P4	VIH1	2.4	VDD +0.2	V	VDD = 5.5V
		1.4	VDD +0.2	V	VDD = 2.2V
Input High Voltage RST	VIH2	3.5	VDD +0.2	V	VDD = 5.5V
		1.7	VDD +0.2	V	VDD = 2.2V
Input High Voltage XTAL1 ^[*4]	VIH3	3.5	VDD +0.2	V	VDD = 5.5V
		1.6	VDD +0.2	V	VDD = 2.2V
Output					
Output Low Voltage P1, P2, P3, P4 <0:4>	VOL1	-	0.45	V	VDD = 4.5V, IOL = +2 mA
		-	0.25	V	VDD = 2.2V, IOL = +1 mA
Output Low Voltage P0, ALE, \overline{PSEN} ^[*4]	VOL2	-	0.45	V	VDD = 4.5V, IOL = +4 mA
		-	0.25	V	VDD = 2.2V, IOL = +2 mA
Sink Current P1, P2, P3 ^[5] , P4<0:4>	ISK1	4	12	mA	VDD = 4.5V, Vs = 0.45V
		1.8	5.4	mA	VDD = 2.2V, Vin = 0.4V
Sink Current P0, ALE, \overline{PSEN} , P4<5:6>	ISK2	10	20	mA	VDD = 4.5V, Vs = 0.45V
		4.5	9	mA	VDD = 2.2V, Vin = 0.4V
Sink Current P3.4 to P3.7 in High-drive Mode	ISK3	15	24	mA	VDD = 4.5V, Vs = 0.45V
		12	24	mA	VDD = 4.5V, Vin = 0.45V



DC Characteristics, continued

PARAMETER	SYM.	SPECIFICATION			TEST CONDITIONS
		MIN.	MAX.	UNIT	
Output High Voltage P1, P2, P3, P4	VOH1	2.4	-	V	V _{DD} = 4.5V, I _{OH} = 100 μA
		1.4	-	V	V _{DD} = 2.2V, I _{OH} = -8 μA
Output High Voltage P0, ALE, $\overline{\text{PSEN}}^{[*4]}$	VOH2	2.4	-	V	V _{DD} = 4.5V, I _{OH} = 100 μA
		1.4	-	V	V _{DD} = 2.2V, I _{OH} = -400 μA
Source Current P1, P2, P3, P4<0:4>	I _{s1}	-120	-250	μA	V _{DD} = 4.5V, V _s = 2.4V
		-12	-33	μA	V _{DD} = 2.2V, V _{in} = 1.4V
Source Current P0, ALE, $\overline{\text{PSEN}}$, P4<5:6>	I _{s2}	-8	-14	mA	V _{DD} = 4.5V, V _s = 2.4V
		-1.1	-2.4	mA	V _{DD} = 2.2V, V _{in} = 1.4V

Notes:

- *1. RST pin has an internal pull-down.
- *2. Pins of P1 and P3 can source a transition current when they are being externally driven from 1 to 0.
- *3. RST is a Schmitt trigger input and XTAL1 is a CMOS input.
- *4. P0, P2, ALE and $\overline{\text{PSEN}}$ are tested in the external access mode.
- *5. P3.4 to P3.7 are in normal mode.

AC CHARACTERISTICS

Clock Input Waveform

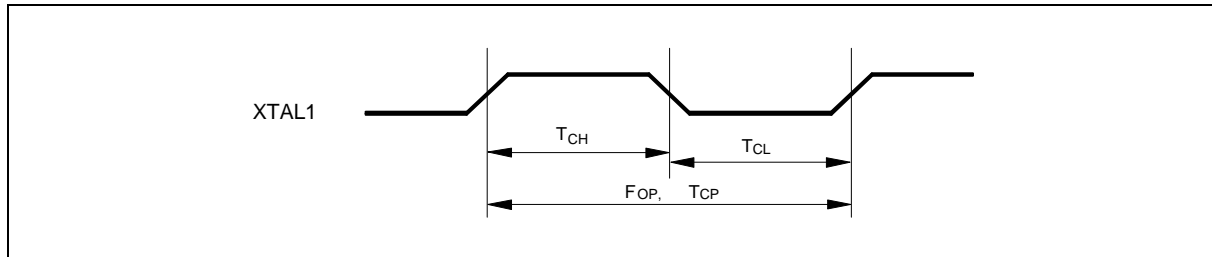

PARAMETER	SYMBOL	MIN.	TYP.	MAX.	UNIT	NOTES
Operating Speed	F _{OP}	0	-	16	MHz	1
Clock Period	T _{CP}	25	-	-	nS	2
Clock High	T _{CH}	10	-	-	nS	3
Clock Low	T _{CL}	10	-	-	nS	3

Notes:

- 1. The clock may be stopped indefinitely in either state.
- 2. The T_{CP} specification is used as a reference in other specifications.
- 3. There are no duty cycle requirements on the XTAL1 input.

Program Fetch Cycle

PARAMETER	SYMBOL	MIN.	TYP.	MAX.	UNIT	NOTES
Address Valid to ALE Low	TAAS	1 TCP - Δ	-	-	nS	4
Address Hold from ALE Low	TAAH	1 TCP - Δ	-	-	nS	1, 4
ALE Low to $\overline{\text{PSEN}}$ Low	TAPL	1 TCP - Δ	-	-	nS	4
$\overline{\text{PSEN}}$ Low to Data Valid	TPDA	-	-	2 TCP	nS	2
Data Hold after $\overline{\text{PSEN}}$ High	TPDH	0	-	1 TCP	nS	3
Data Float after $\overline{\text{PSEN}}$ High	TPDZ	0	-	1 TCP	nS	
ALE Pulse Width	TALW	2 TCP - Δ	2 TCP	-	nS	4
$\overline{\text{PSEN}}$ Pulse Width	TPSW	3 TCP - Δ	3 TCP	-	nS	4

Notes:

1. P0.0–P0.7, P2.0–P2.7 remain stable throughout entire memory cycle.
2. Memory access time is 3 TCP.
3. Data have been latched internally prior to $\overline{\text{PSEN}}$ going high.
4. " Δ " (due to buffer driving delay and wire loading) is 20 nS.

Data Read Cycle

PARAMETER	SYMBOL	MIN.	TYP.	MAX.	UNIT	NOTES
ALE Low to $\overline{\text{RD}}$ Low	TDAR	3 TCP - Δ	-	3 TCP + Δ	nS	1, 2
$\overline{\text{RD}}$ Low to Data Valid	TDDA	-	-	4 TCP	nS	1
Data Hold from $\overline{\text{RD}}$ High	TDDH	0	-	2 TCP	nS	
Data Float from $\overline{\text{RD}}$ High	TDDZ	0	-	2 TCP	nS	
$\overline{\text{RD}}$ Pulse Width	TDRD	6 TCP - Δ	6 TCP	-	nS	2

Notes:

1. Data memory access time is 8 TCP.
2. " Δ " (due to buffer driving delay and wire loading) is 20 nS.

Data Write Cycle

PARAMETER	SYMBOL	MIN.	TYP.	MAX.	UNIT
ALE Low to $\overline{\text{WR}}$ Low	TDAW	3 TCP - Δ	-	3 TCP + Δ	nS
Data Valid to $\overline{\text{WR}}$ Low	TDAD	1 TCP - Δ	-	-	nS
Data Hold from $\overline{\text{WR}}$ High	TDWD	1 TCP - Δ	-	-	nS
$\overline{\text{WR}}$ Pulse Width	TDWR	6 TCP - Δ	6 TCP	-	nS

Note: " Δ " (due to buffer driving delay and wire loading) is 20 nS.

Port Access Cycle

PARAMETER	SYMBOL	MIN.	TYP.	MAX.	UNIT
Port Input Setup to ALE Low	TPDS	1 TCP	-	-	nS
Port Input Hold from ALE Low	TPDH	0	-	-	nS
Port Output to ALE	TPDA	1 TCP	-	-	nS

Note: Ports are read during S5P2, and output data becomes available at the end of S6P2. The timing data are referenced to ALE, since it provides a convenient reference.

TIMING WAVEFORMS

Program Fetch Cycle

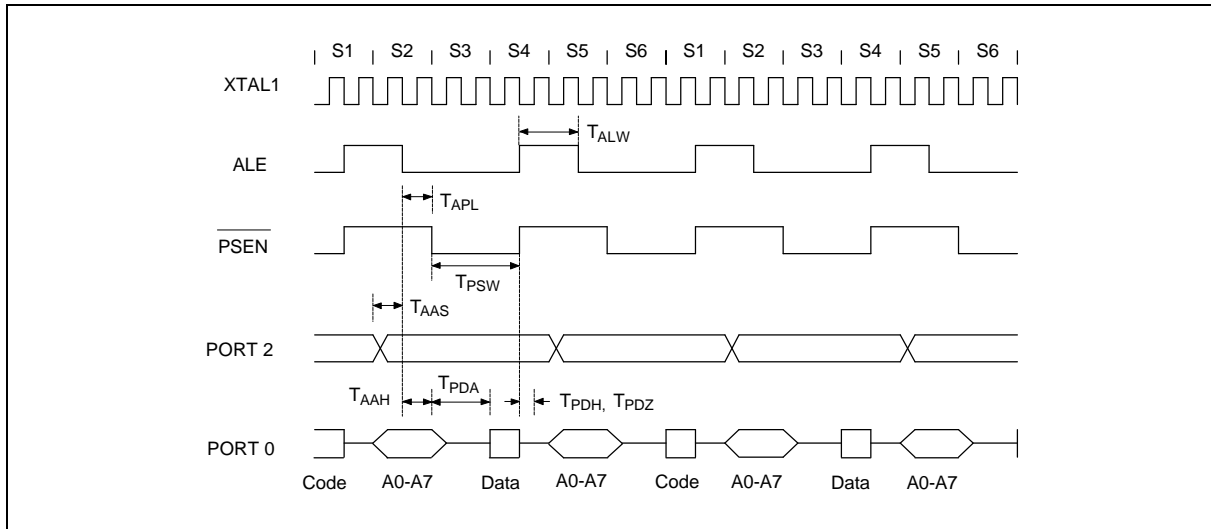

Data Read Cycle

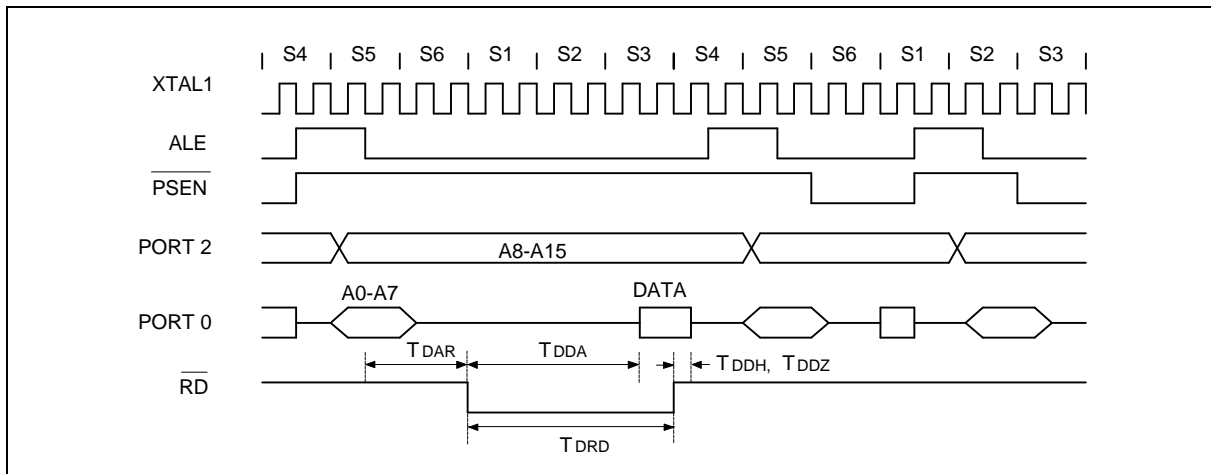

Timing Waveforms, continued

Data Write Cycle

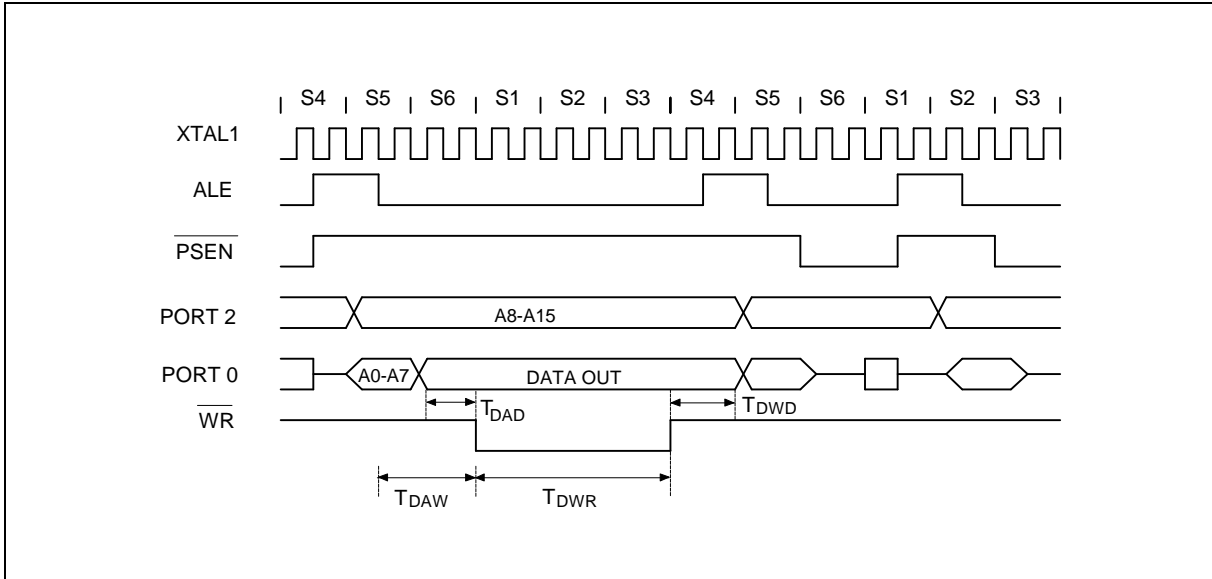

Port Access Cycle

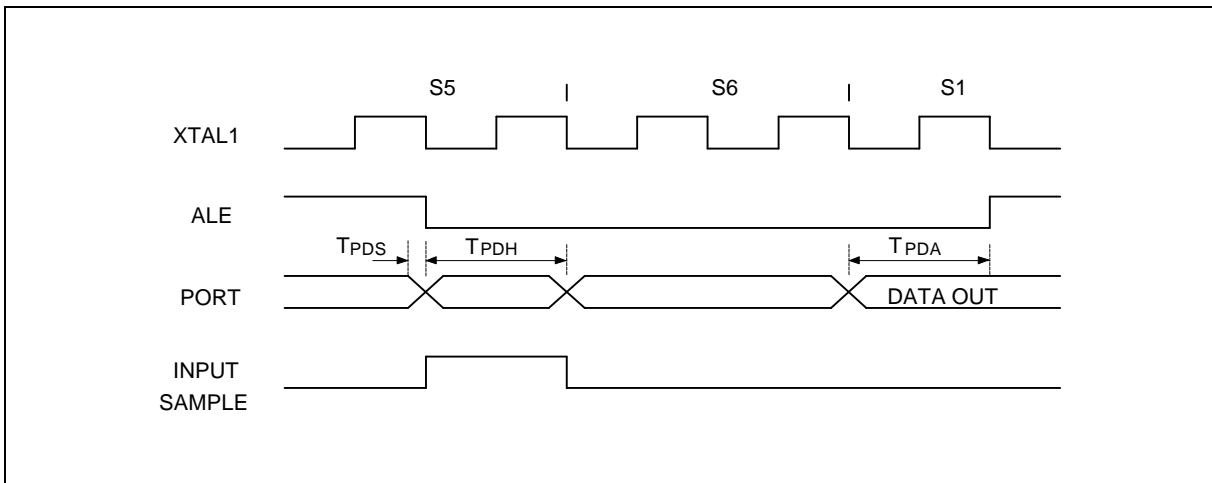

PACKAGE DIMENSIONS

40-pin DIP

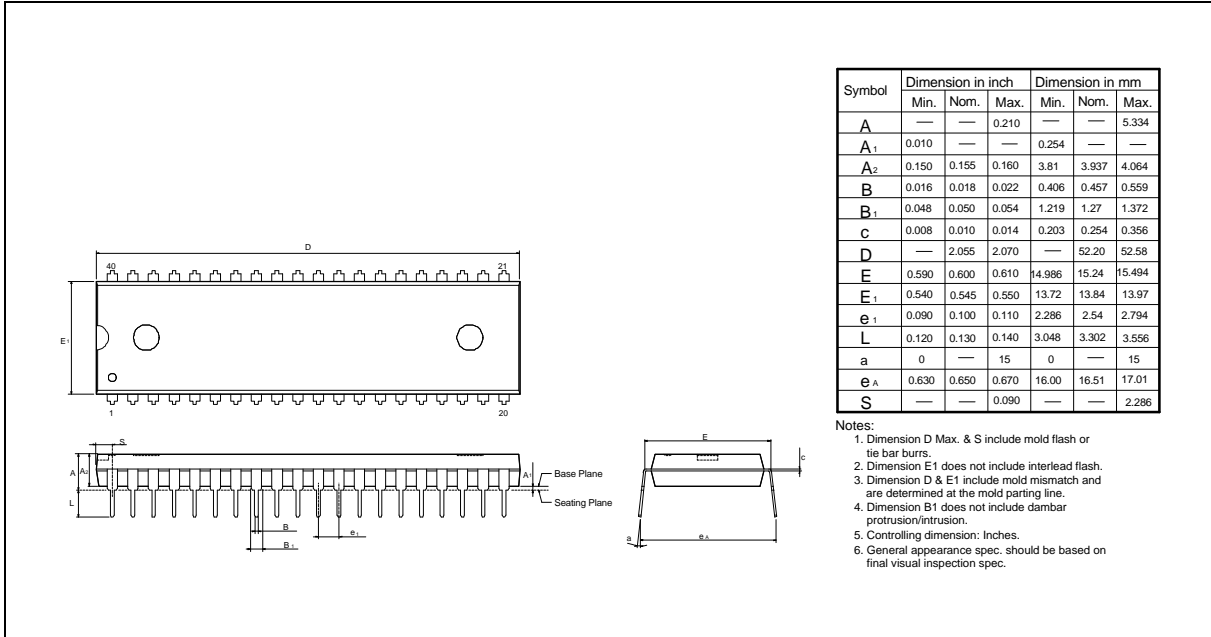

44-pin PLCC

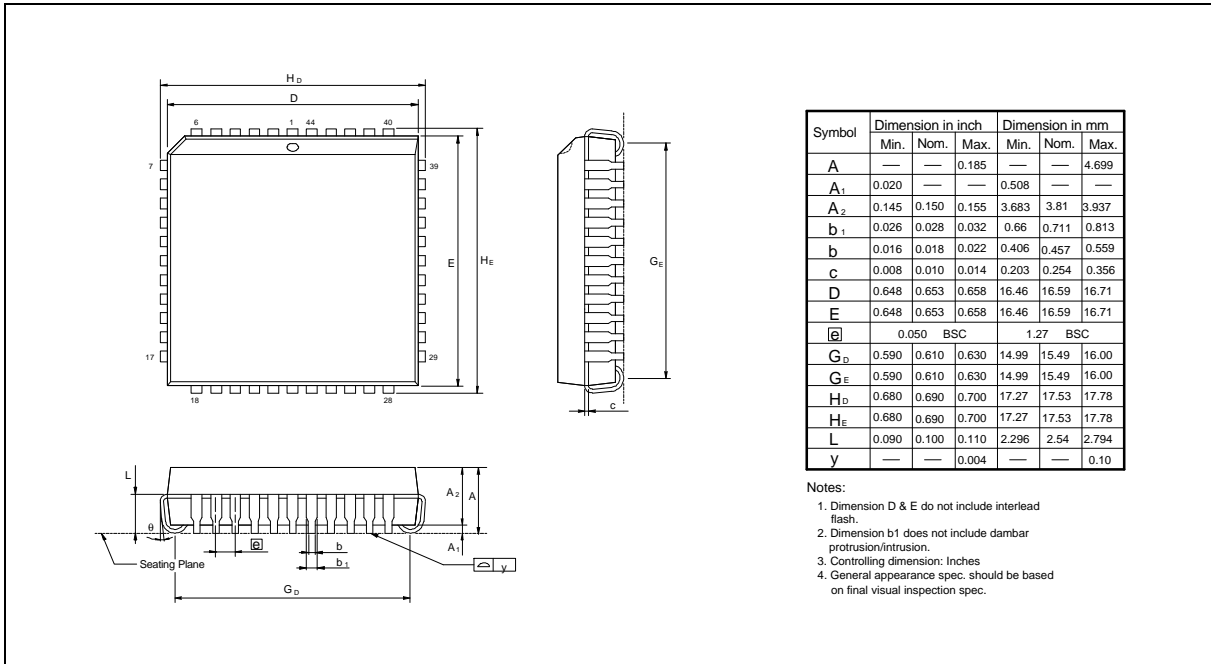

Package Dimensions, continued

44-pin PQFP

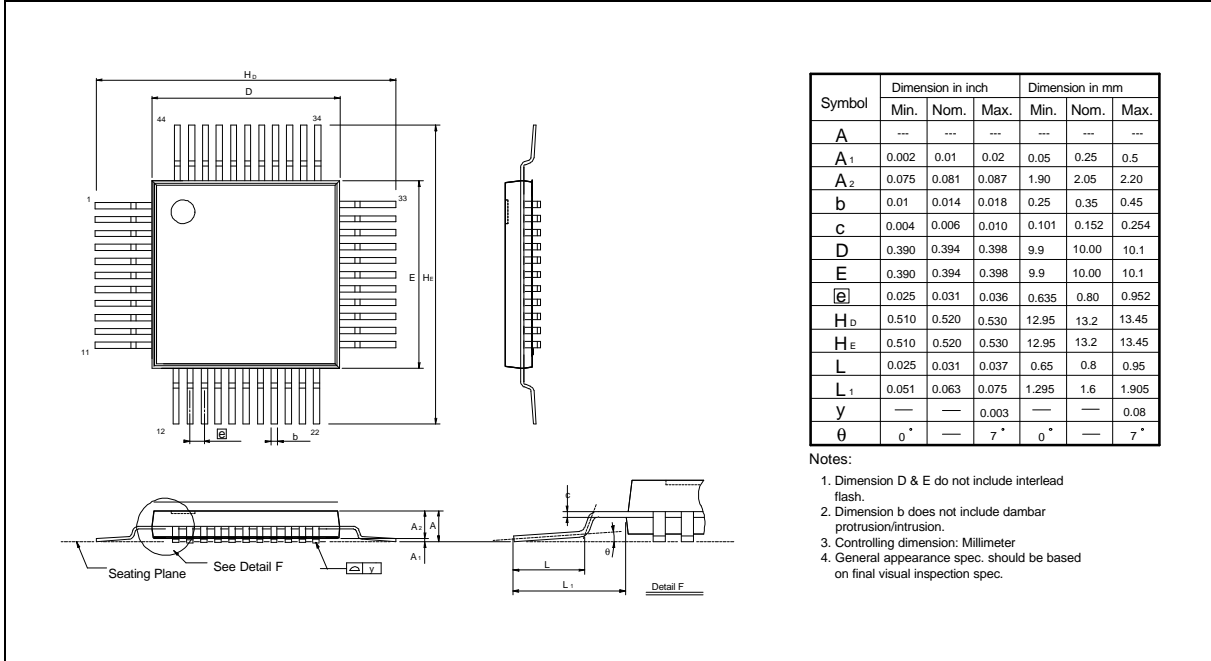

KEYBOARD APPLICATION CIRCUIT

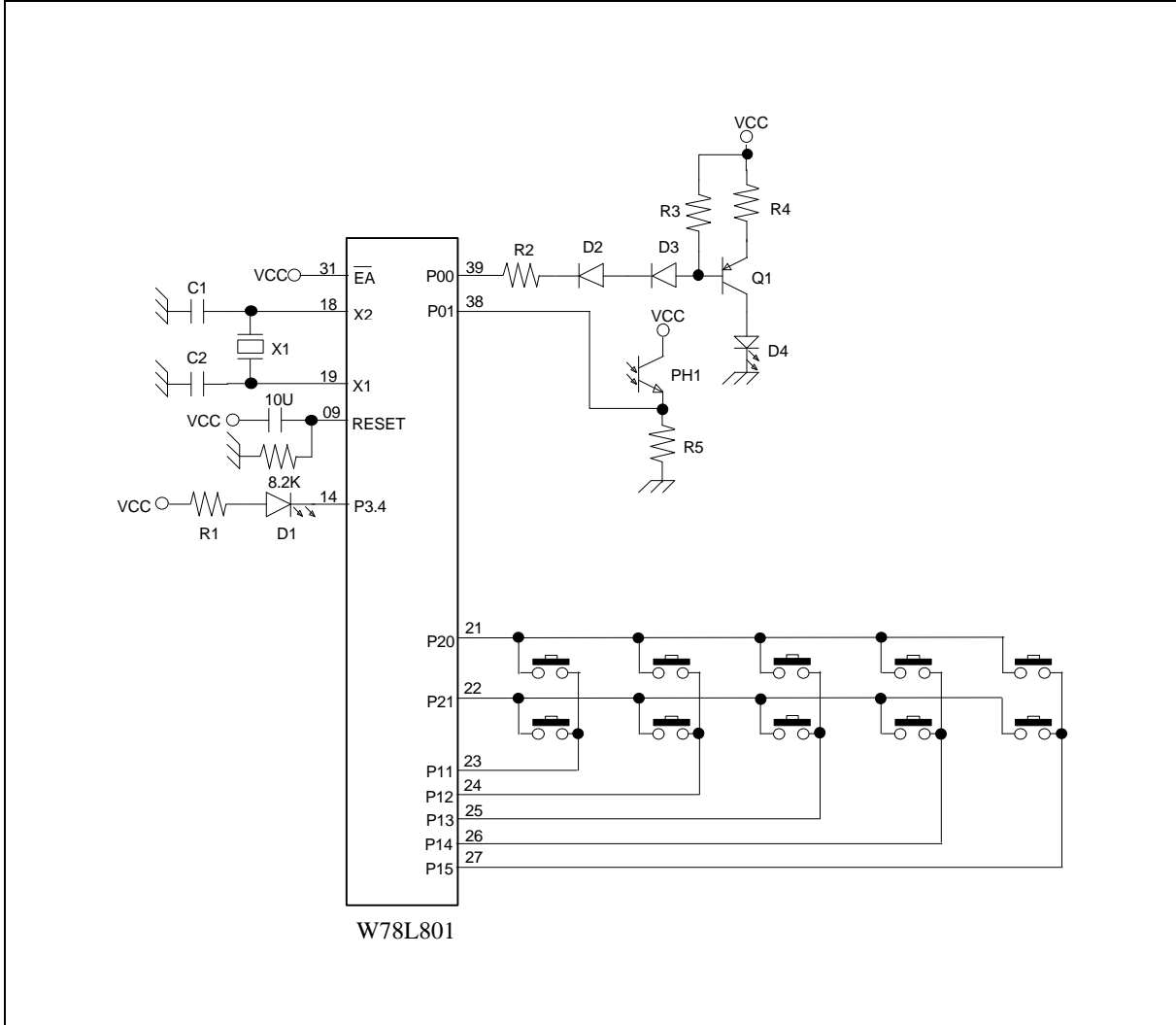



Headquarters

No. 4, Creation Rd. III,
Science-Based Industrial Park,
Hsinchu, Taiwan
TEL: 886-3-5770066
FAX: 886-3-5792766
<http://www.winbond.com.tw/>
Voice & Fax-on-demand: 886-2-27197006

Taipei Office

11F, No. 115, Sec. 3, Min-Sheng East Rd.,
Taipei, Taiwan
TEL: 886-2-27190505
FAX: 886-2-27197502

Winbond Electronics (H.K.) Ltd.

Rm. 803, World Trade Square, Tower II,
123 Hoi Bun Rd., Kwun Tong,
Kowloon, Hong Kong
TEL: 852-27513100
FAX: 852-27552064

Winbond Electronics North America Corp.

Winbond Memory Lab.
Winbond Microelectronics Corp.
Winbond Systems Lab.
2727 N. First Street, San Jose,
CA 95134, U.S.A.
TEL: 408-9436666
FAX: 408-5441798

Note: All data and specifications are subject to change without notice.