

Preliminary W78E365



8-BIT MICROCONTROLLER

GENERAL DESCRIPTION

The **W78E365** is an 8-bit microcontroller which has an in-system programmable FLASH EPROM for firmware updating. The instruction set of the W78E365 is fully compatible with the standard 8052. The W78E365 contains a 64K bytes of main FLASH EPROM and a 4K bytes of auxiliary FLASH EPROM which allows the contents of the 64KB main FLASH EPROM to be updated by the loader program located at the 4KB auxiliary FLASH EPROM; 1K bytes of on-chip AUX RAM; four 8-bit bi-directional and bit-addressable I/O ports; an additional 4-bit port P4; three 16-bit timer/counters; a serial port. These peripherals are supported by a eight sources two-level interrupt capability. To facilitate programming and verification, the FLASH EPROM inside the W78E365 allows the program memory to be programmed and read electronically. Once the code is confirmed, the user can protect the code for security.

The W78E365 microcontroller has two power reduction modes, idle mode and power-down mode, both of which are software selectable. The idle mode turns off the processor clock but allows for continued peripheral operation. The power-down mode stops the crystal oscillator for minimum power consumption. The external clock can be stopped at any time and in any state without affecting the processor.

FEATURES

- Fully static design 8-bit CMOS microcontroller up to 40 MHz.
- 12 clocks per machine instruction cycle
- 64K bytes of in-system programmable FLASH EPROM for Application Program (APROM).
- 4K bytes of auxiliary FLASH EPROM for Loader Program (LDROM).
- 1K +256 bytes of on-chip RAM. (including 1K bytes of AUX-RAM, software selectable)
- 64K bytes program memory address space and 64K bytes data memory address space.
- 5 channels PWM (P1.3~P1.7 software controllable)
- Four 8-bit bi-directional ports.
- Additional direct LED drive outputs through P4.4 ~ P4.7 (only for 48-pin LQFP package)
- Three 16-bit timer/counters
- One full duplex serial port
- Eight-sources, two-level interrupt capability
- Watchdog timer
- Built-in power management
- Code protection
- PACKAGE
 - PDIP 40: W78E365-24/40
 - PLCC 44: W78E365P-24/40
 - PQFP 44: W78E365F-24/40
 - LQFP 48: W78E365D-24/40

Publication Release Date: April 2001

PIN CONFIGURATIONS

40-pin DIP (W78E365)

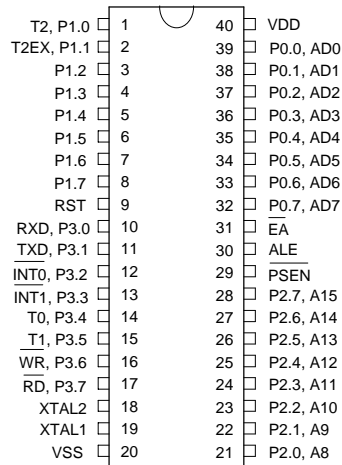

44-pin PLCC (W78E365P)

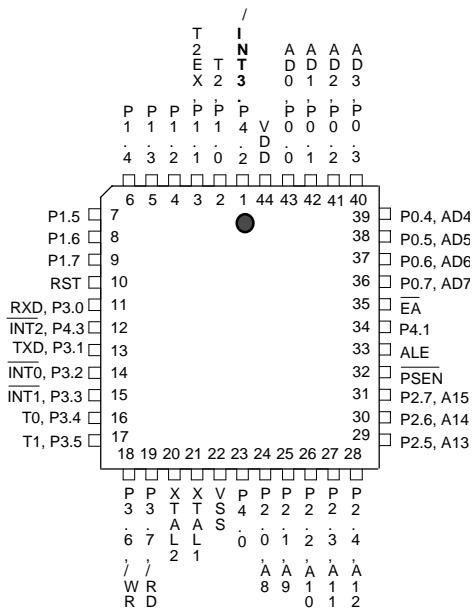

Preliminary W78E365

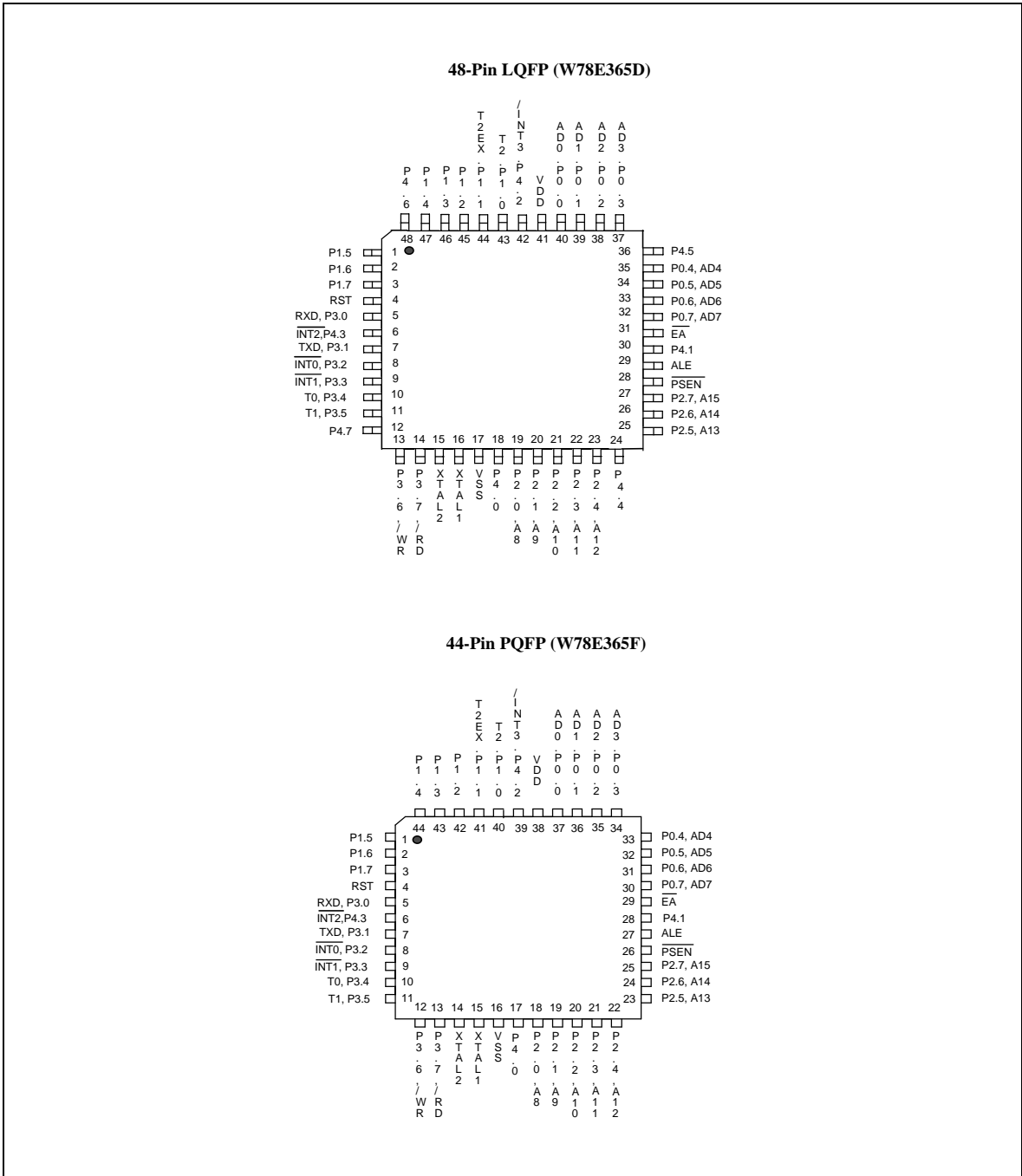

Preliminary W78E365



PIN DESCRIPTION

SYMBOL	TYPE	DESCRIPTIONS
\overline{EA}	I	EXTERNAL ACCESS ENABLE: This pin forces the processor to execute the external ROM. The ROM address and data will not be presented on the bus if the \overline{EA} pin is high and the program counter is within the 64 KB area.
\overline{PSEN}	O H	PROGRAM STORE ENABLE: \overline{PSEN} enables the external ROM data in the Port 0 address/data bus. When internal ROM access is performed, no \overline{PSEN} strobe signal outputs originate from this pin.
ALE	O H	ADDRESS LATCH ENABLE: ALE is used to enable the address latch that separates the address from the data on Port 0. ALE runs at 1/6th of the oscillator frequency. An ALE pulse is omitted during external data memory accesses.
RST	I L	RESET: A high on this pin for two machine cycles while the oscillator is running resets the device.
XTAL1	I	CRYSTAL 1: This is the crystal oscillator input. This pin may be driven by an external clock.
XTAL2	O	CRYSTAL 2: This is the crystal oscillator output. It is the inversion of XTAL1.
Vss	I	GROUND: ground potential.
VDD	I	POWER SUPPLY: Supply voltage for operation.
P0.0–P0.7	I/O D	PORT 0: Function is the same as that of standard 8052. (Default) PORT 0 can be programming configured to standard port with internal pull-ups
P1.0–P1.7	I/O H	PORT 1: Function is the same as that of standard 8052. The ports P1.3–P1.7 also provide alternated function of PWM. See details below.
P2.0–P2.7	I/O H	PORT 2: Port 2 is a bi-directional I/O port with internal pull-ups. This port also provides the upper address bits for accesses to external memory.
P3.0–P3.7	I/O H	PORT 3: Function is the same as that of the standard 8052.
P4.0–P4.7	I/O H	PORT 4: A bi-directional I/O port with alternate function. P4.4~P4.7 are direct LED drive outputs (20 mA) and are available on 48-pin LQFP package

* Note : **TYPE** I: input, O: output, I/O: bi-directional, H: pull-high, L: pull-low, D: open drain

Port 4

Port 4, SFR P4 at address D8H

Preliminary W78E365



BLOCK DIAGRAM

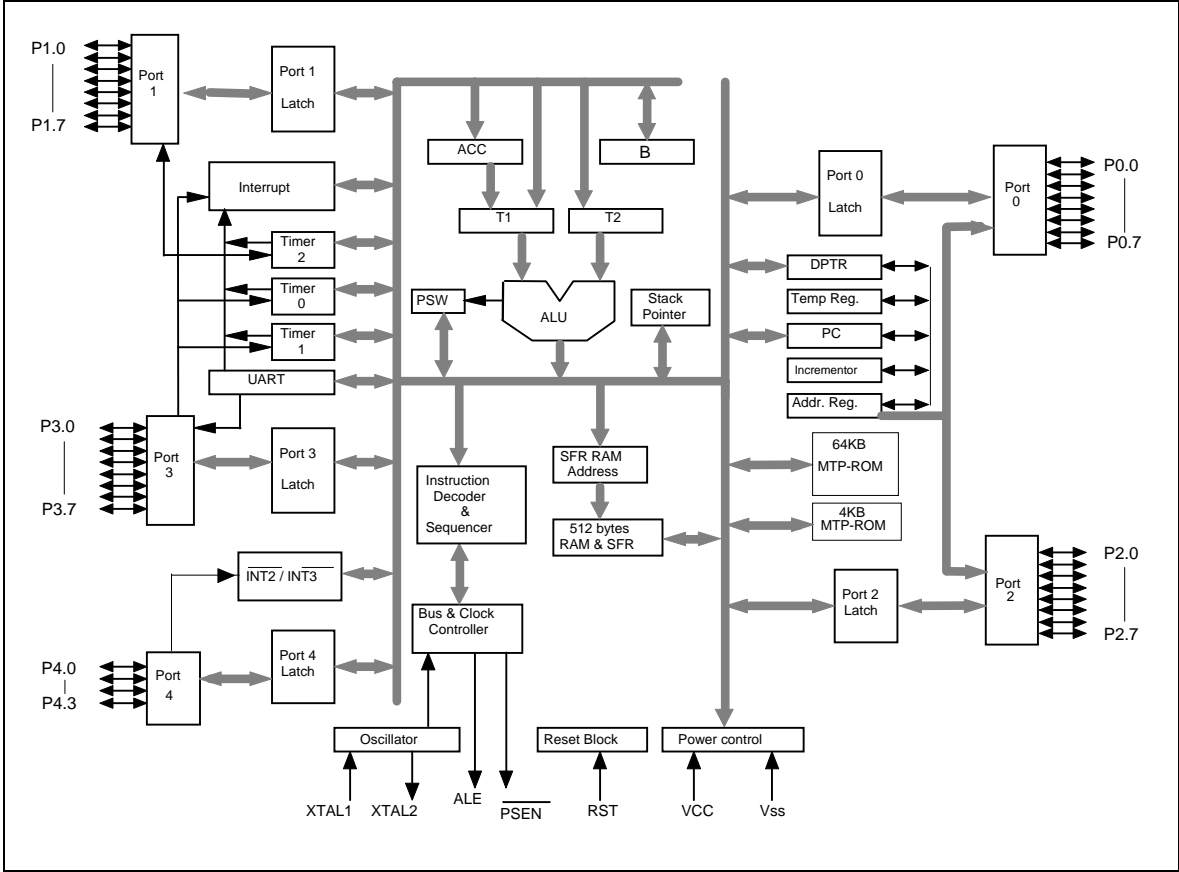



FUNCTIONAL DESCRIPTION

The W78E365 architecture consists of a core controller surrounded by various registers, four general purpose I/O ports, one special purpose programmable 4-bits I/O port, 1K bytes of RAM, three timer/counters and a serial port. The processor supports 111 different opcodes and references both a 64K program address space and a 64 K data storage space.

RAM

The internal data RAM in the W78E365 is 1K bytes. It is divided into two banks: 256 bytes of scratchpad RAM and 1K bytes of AUX-RAM. These RAMs are addressed by different ways.

- RAM 0H–7FH can be addressed directly and indirectly as the same as in 8051. Address pointers are R0 and R1 of the selected register bank.
- RAM 80H–03FFH can only be addressed indirectly as the same as in 8051. Address pointers are R0, R1 of the selected registers bank.
- AUX-RAM 0H–03FFH is addressed indirectly as the same way to access external data memory with the MOVX instruction. Address pointer are R0 and R1 of the selected register bank and DPTR register. An access to external data memory locations higher than 03FFH will be performed with the MOVX instruction in the same way as in the 8051. The AUX-RAM is disable after a reset. Setting the bit 4 in CHPCON register will enable the access to AUX-RAM. When AUX-RAM is enabled the instructions of "MOVX @Ri" will always access to on-chip AUX-RAM. When executing from internal program memory, an access to AUX-RAM will not affect the Ports P0, P2, WR and RD.

Timers 0, 1, and 2

Timers 0, 1, and 2 each consist of two 8-bit data registers. These are called TL0 and TH0 for Timer 0, TL1 and TH1 for Timer 1, and TL2 and TH2 for Timer 2. The TCON and TMOD registers provide control functions for timers 0, 1. The T2CON register provides control functions for Timer 2. RCAP2H and RCAP2L are used as reload/capture registers for Timer 2.

The operations of Timer 0 and Timer 1 are the same as in the W78C51. Timer 2 is a 16-bit timer/counter that is configured and controlled by the T2CON register. Like Timers 0 and 1, Timer 2 can operate as either an external event counter or as an internal timer, depending on the setting of bit C/T2 in T2CON. Timer 2 has three operating modes: capture, auto-reload, and baud rate generator. The clock speed at capture or auto-reload mode is the same as that of Timers 0 and 1.

INT2 / INT3

Two additional external interrupts, INT2 and INT3, whose functions are similar to those of external interrupt 0 and 1 in the standard 80C52. The functions/status of these interrupts are determined/shown by the bits in the XICON (External Interrupt Control) register. The XICON register is bit-addressable but is not a standard register in the standard 80C52. Its address is at 0C0H. To set/clear bits in the XICON register, one can use the "SETB (CLR) bit" instruction. For example, "SETB 0C2H" sets the EX2 bit of XICON.

Preliminary W78E365



XICON - external interrupt control (C0H)

PX3	EX3	IE3	IT3	PX2	EX2	IE2	IT2
-----	-----	-----	-----	-----	-----	-----	-----

PX3: External interrupt 3 priority high if set

EX3: External interrupt 3 enable if set

IE3: If IT3 = 1, IE3 is set/cleared automatically by hardware when interrupt is detected/serviced

IT3: External interrupt 3 is falling-edge/low-level triggered when this bit is set/cleared by software

PX2: External interrupt 2 priority high if set

EX2: External interrupt 2 enable if set

IE2: If IT2 = 1, IE2 is set/cleared automatically by hardware when interrupt is detected/serviced

IT2: External interrupt 2 is falling-edge/low-level triggered when this bit is set/cleared by software

Eight-source interrupt informations:

INTERRUPT SOURCE	VECTOR ADDRESS	POLLING SEQUENCE WITHIN PRIORITY LEVEL	ENABLE REQUIRED SETTINGS	INTERRUPT TYPE EDGE/LEVEL
External Interrupt 0	03H	0 (highest)	IE.0	TCON.0
Timer/Counter 0	0BH	1	IE.1	-
External Interrupt 1	13H	2	IE.2	TCON.2
Timer/Counter 1	1BH	3	IE.3	-
Serial Port	23H	4	IE.4	-
Timer/Counter 2	2BH	5	IE.5	-
External Interrupt 2	33H	6	XICON.2	XICON.0
External Interrupt 3	3BH	7 (lowest)	XICON.6	XICON.3

Clock

The W78E365 is designed to be used with either a crystal oscillator or an external clock. Internally, the clock is divided by two before it is used by default. This makes the W78E365 relatively insensitive to duty cycle variations in the clock.

Crystal Oscillator

The W78E365 incorporates a built-in crystal oscillator. To make the oscillator work, a crystal must be connected across pins XTAL1 and XTAL2. In addition, a load capacitor must be connected from each pin to ground, and a resistor must also be connected from XTAL1 to XTAL2 to provide a DC bias when the crystal frequency is above 24 MHz.

External Clock

An external clock should be connected to pin XTAL1. Pin XTAL2 should be left unconnected. The XTAL1 input is a CMOS-type input, as required by the crystal oscillator. As a result, the external clock signal should have an input one level of greater than 3.5 volts.



Power Management

Idle Mode

The idle mode is entered by setting the IDL bit in the PCON register. In the idle mode, the internal clock to the processor is stopped. The peripherals and the interrupt logic continue to be clocked. The processor will exit idle mode when either an interrupt or a reset occurs.

Power-down Mode

When the PD bit in the PCON register is set, the processor enters the power-down mode. In this mode all of the clocks are stopped, including the oscillator. To exit from power-down mode is by a hardware reset or external interrupts INT0 to INT3 when enabled and set to level triggered.

Reduce EMI Emission

The W78E365 allows user to diminish the gain of on-chip oscillator amplifier by using programmer to clear the B7 bit of security register. Once B7 is set to 0, a half of gain will be decreased. Care must be taken if user attempts to diminish the gain of oscillator amplifier, reducing a half of gain may affect the external crystal operating improperly at high frequency above 24 MHz. The value of R and C1,C2 may need some adjustment while running at lower gain.

Reset

The external RESET signal is sampled at S5P2. To take effect, it must be held high for at least two machine cycles while the oscillator is running. An internal trigger circuit in the reset line is used to deglitch the reset line when the W78E365 is used with an external RC network. The reset logic also has a special glitch removal circuit that ignores glitches on the reset line. During reset, the ports are initialized to FFH, the stack pointer to 07H, PCON (with the exception of bit 4) to 00H, and all of the other SFR registers except SBUF to 00H. SBUF is not reset.

W78E365 Special Function Registers (SFRs) and Reset Values

F8									FF
F0	+B 00000000						CHPENR 00000000		F7
E8									EF
E0	+ACC 00000000								E7
D8	+P4 xxxx1111								DF
D0	+PSW 00000000								D7
C8	+T2CON 00000000	RCAP2L 00000000	RCAP2H 00000000	TL2 00000000	TH2 00000000				CF
C0	XICON 00000000	P4CONA 00000000	P4CONB 00000000	SFRAL 00000000	SFRAH 00000000	SFRFD 00000000	SFRCN 00000000		C7
B8	+IP 00000000							CHPCON 0xx00000	BF

Preliminary W78E365



W78E365 Special Function Registers (SFRs) and Reset Values, continued

B0	+P3 00000000				P43AL 00000000	P43AH 00000000			B7
A8	+IE 00000000				P42AL 00000000	P42AH 00000000	P2ECON 0000xx00		AF
A0	+P2 11111111								A7
98	+SCON 00000000	SBUF xxxxxxx					P2EAL 00000000	P2EAH 00000000	9F
90	+P1 11111111				P41AL 00000000	P41AH 00000000			97
88	+TCON 00000000	TMOD 00000000	TL0 00000000	TL1 00000000	TH0 00000000	TH1 00000000			8F
80	+P0 11111111	SP 00000111	DPL 00000000	DPH 00000000	P40AL 00000000	P40AH 00000000		PCON 00110000	87

- Note: 1. The SFRs marked with a plus sign(+) are both byte- and bit-addressable.
 2. The text of SFR with bold type characters are extension function registers.

P4CONB (C3H)

BIT	NAME	FUNCTION
7, 6	P43FUN1 P43FUN0	00: Mode 0. P4.3 is a general purpose I/O port which is the same as Port1. 01: Mode 1. P4.3 is a Read Strobe signal for chip select purpose. The address range depends on the SFR P43AH, P43AL, P43CMP1 and P43CMP0. 10: Mode 2. P4.3 is a Write Strobe signal for chip select purpose. The address range depends on the SFR P43AH, P43AL, P43CMP1 and P43CMP0. 11: Mode 3. P4.3 is a Read/Write Strobe signal for chip select purpose. The address range depends on the SFR P43AH, P43AL, P43CMP1, and P43CMP0.
5, 4	P43CMP1 P43CMP0	Chip-select signals address comparison: 00: Compare the full address (16 bits length) with the base address register P43AH, P43AL. 01: Compare the 15 high bits (A15–A1) of address bus with the base address register P43AH, P43AL. 10: Compare the 14 high bits (A15–A2) of address bus with the base address register P43AH, P43AL. 11: Compare the 8 high bits (A15–A8) of address bus with the base address register P43AH, P43AL.
3, 2	P42FUN1 P42FUN0	The P4.2 function control bits which are the similar definition as P43FUN1, P43FUN0.
1, 0	P42CMP1 P42CMP0	The P4.2 address comparator length control bits which are the similar definition as P43CMP1, P43CMP0.



P4CONA (C2H)

BIT	NAME	FUNCTION
7, 6	P41FUN1 P41FUN0	The P4.1 function control bits which are the similar definition as P43FUN1, P43FUN0.
5, 4	P41CMP1 P41CMP0	The P4.1 address comparator length control bits which are the similar definition as P43CMP1, P43CMP0.
3, 2	P40FUN1 P40FUN0	The P4.0 function control bits which are the similar definition as P43FUN1, P43FUN0.
1, 0	P40CMP1 P40CMP0	The P4.0 address comparator length control bits which are the similar definition as P43CMP1, P43CMP0.

Port 4 Base Address Registers

P40AH, P40AL:

The Base address register for comparator of P4.0. P40AH contains the high-order byte of address, P40AL contains the low-order byte of address.

P41AH, P41AL:

The Base address register for comparator of P4.1. P41AH contains the high-order byte of address, P41AL contains the low-order byte of address.

P42AH, P42AL:

The Base address register for comparator of P4.2. P42AH contains the high-order byte of address, P42AL contains the low-order byte of address.

P43AH, P43AL:

The Base address register for comparator of P4.3. P43AH contains the high-order byte of address, P43AL contains the low-order byte of address.

The SFR for Port 4

P4 (D8H)

BIT	NAME	FUNCTION
7	-	Reserve
6	-	Reserve
5	-	Reserve
4	-	Reserve
3	P43	Port 4 Data bit which outputs to pin P4.3 at mode 0.
2	P42	Port 4 Data bit. which outputs to pin P4.2 at mode 0.
1	P41	Port 4 Data bit. which outputs to pin P4.1at mode 0.
0	P40	Port 4 Data bit which outputs to pin P4.0 at mode 0.

Preliminary W78E365



Here is an example to program the P4.0 as a write strobe signal at the I/O port address 1234H–1237H and positive polarity, and P4.1–P4.3 are used as general I/O ports.

```

MOV P40AH,#12H
MOV P40AL,#34H           ; Define the base I/O address 1234H for P4.0 as an special function
                          ; pin
MOV P4CONA,#00001010B   ; Define the P4.0 as a write strobe signal pin and the comparator
                          ; length ;is 14
MOV P4CONB,#00H         ; P4.1–P4.3 as general I/O port which are the same as PORT1
MOV P2ECON,#10H        ; Write the P40SINV = 1 to inverse the P4.0 write strobe polarity
                          ; default is negative.
MOV CHPENR,#00H        ; Disable CHPCON write attribute.
    
```

Then any instruction `MOVX @DPTR,A` (with `DPTR = 1234H–1237H`) will generate the positive polarity write strobe signal at pin P4.0. And the instruction `MOV P4,#XX` will output the bit3 to bit1 of data #XX to pin P4.3–P4.1.

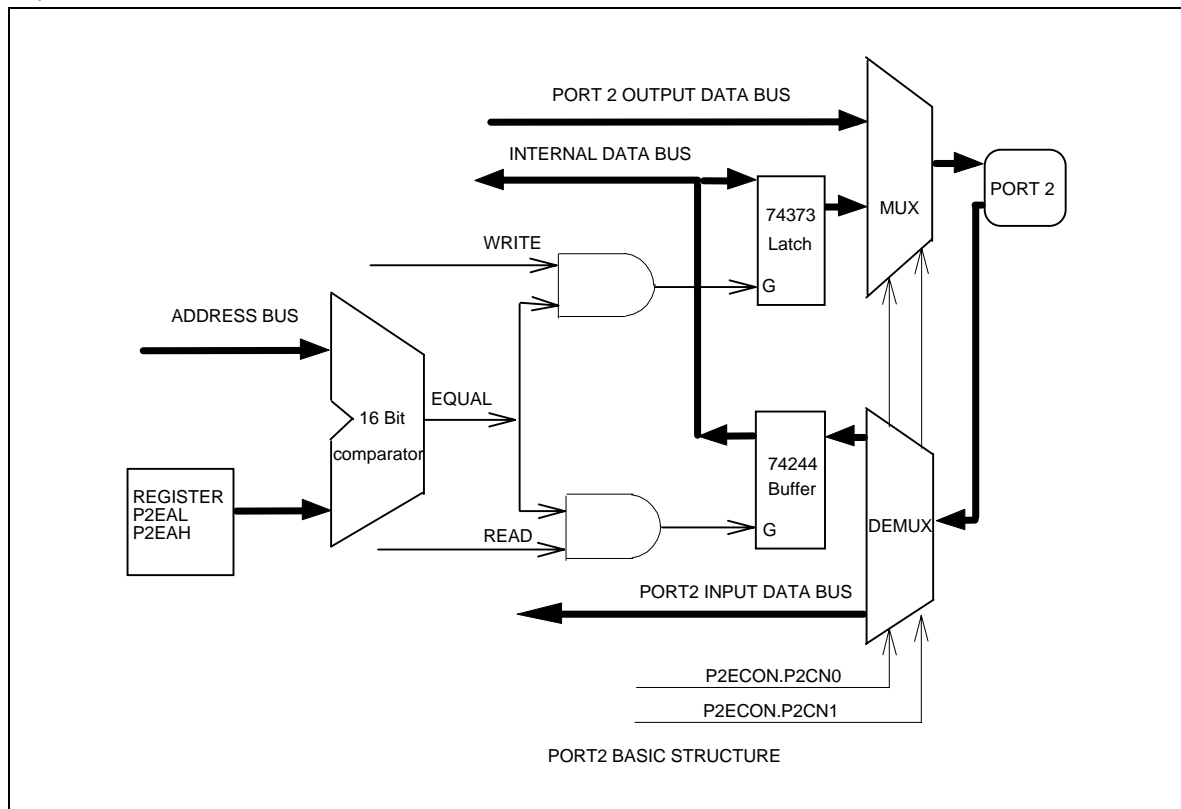

Preliminary W78E365



P2EAH, P2EAL:

The Port Enable Address Registers for Port2 as an Input Buffer/Output-Latched Port.

The I/O port enable address is need to assign when Port2 is defined as input buffer like a 74244, or a output-latched logic like a 74373. The P2EAH contains the high-order byte of address, the P2EAL contains the low-order byte of address. The following example shows how to program the Port 2 as a output-latched port at address 5678H.

```
MOV P2EAL,#78H      ; High-order byte of address to enable Port2 latch function.
MOV P2EAH,#56H      ; Low-order byte of address to enable Port2 latch function.
MOV P2ECON,#02H     ; Configure the Port2 as an output-latched port.
MOV DPTR,#5678H     ; Move data 5678H to DPTR.
MOV A, #55H
MOVX @DPTR, A       ; The pins P2.7–P2.0 will output and latch the value 55H.
```

When Port2 is configured as 74244 or 74373 function, the instruction " MOV P2,#XX " will write the data #XX to P2 register only but not output to port pins P2.7–P2.0.

Port 2 Expanded Control Register(P2ECON).

P2ECON (AEH)

BIT	NAME	FUNCTION
7	P43CSINV	The active polarity of P4.3 when pin P4.3 is defined as read and/or write strobe signal. = 1 : P4.3 is active high when pin P4.3 is defined as read and/or write strobe signal. = 0 : P4.3 is active low when pin P4.3 is defined as read and/or write strobe signal.
6	P42CSINV	The similarity definition as P43SINV.
5	P41CSINV	The similarity definition as P43SINV.
4	P40CSINV	The similarity definition as P43SINV.
3	-	Reserve
2	-	Reserve
1, 0	P2CN1, P2CN0	00 : Pins P2.7–P2.0 is the standard 8051 Port 2. 01 : Pins P2.7–P2.0 is input buffer port which the port enable address depends on the content of P2EAL and P2EAH 10 : Pins P2.7–P2.0 is output-latched port which the port enable address depends on the content of P2EAL and P2EAH. 11 : Undefined.

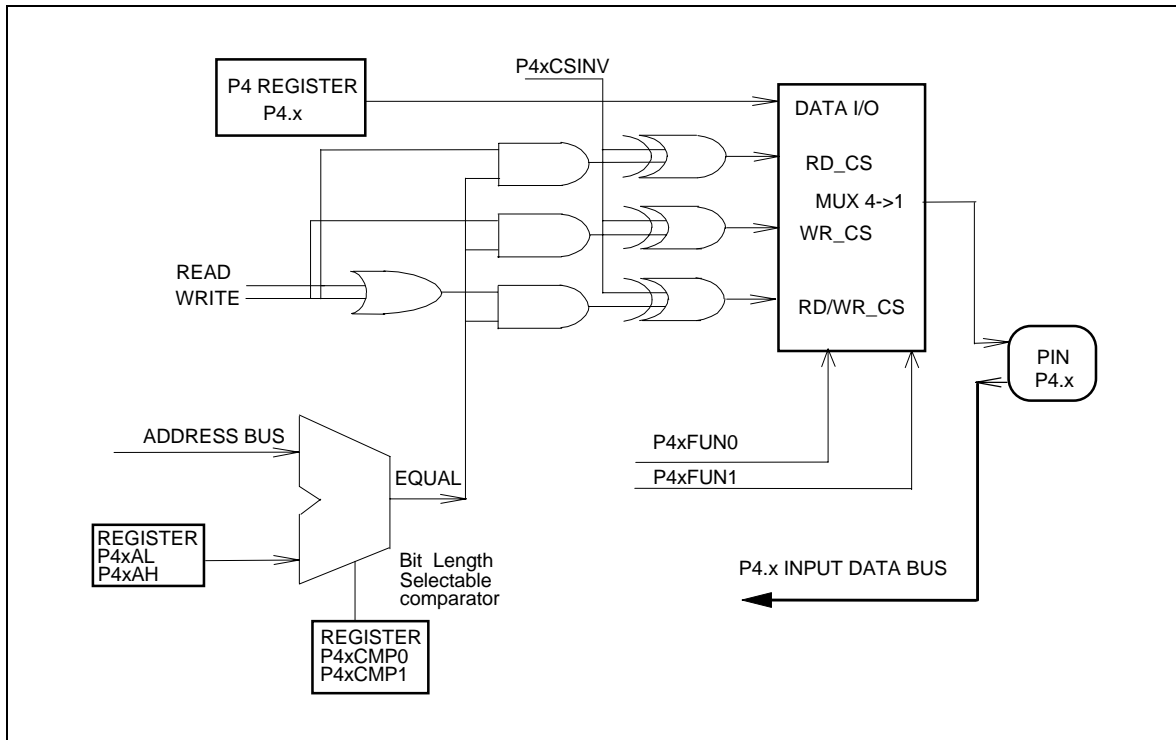

Port 4 Block Diagram

In-System Programming (ISP) Mode

The W78E365 equips one 64K byte of main FLASH EPROM bank for application program (called APROM) and one 4K byte of auxiliary FLASH EPROM bank for loader program (called LDROM). In the normal operation, the microcontroller executes the code in the APROM. If the content of APROM needs to be modified, the W78E365 allows user to activate the In-System Programming (ISP) mode by setting the CHPCON register. **The CHPCON is read-only by default, software must write two specific values 87H, then 59H sequentially to the CHPENR register to enable the CHPCON write attribute. Writing CHPENR register with the values except 87H and 59H will close CHPCON register write attribute.** The W78E365 achieves all in-system programming operations including enter/exit ISP Mode, program, erase, read ...etc, during device in the idle mode. Setting the bit CHPCON.0 the device will enter in-system programming mode after a wake-up from idle mode. Because device needs proper time to complete the ISP operations before awakened from idle mode, software may use timer interrupt to control the duration for wake-up from idle mode. This in-system programming feature makes the job easy and efficient in which the application needs to update firmware frequently. In some applications, the in-system programming feature make it possible that the end-user is able to easily update the system firmware by themselves without opening the chassis.

Preliminary W78E365



SFRAH,SFRAL:

The objective address of on-chip FLASH EPROM in the in-system programming mode. SFRFAH contains the high-order byte of address, SFRFAL contains the low-order byte of address.

SFRFD:

The programming data for on-chip FLASH EPROM in programming mode.

SFRCN:

The control byte of on-chip FLASH EPROM programming mode.

SFRCN (C7)

BIT	NAME	FUNCTION
7	-	Reserve.
6	WFWIN	On-chip FLASH EPROM bank select for in-system programming. = 0 : 64K bytes FLASH EPROM bank is selected as destination for re-programming. = 1 : 4K bytes FLASH EPROM bank is selected as destination for re-programming.
5	OEN	FLASH EPROM output enable.
4	CEN	FLASH EPROM chip enable.
3, 2, 1, 0	CTRL[3:0]	The flash control signals

Mode	WFWIN	CTRL<3:0>	OEN	CEN	SFRAH,SFRAL	SFRFD
Erase 64 KB APROM	0	0010	1	0	X	X
Program 64 KB APROM	0	0001	1	0	Address in	Data in
Read 64 KB APROM	0	0000	0	0	Address in	Data out
Erase 4 KB LDROM	1	0010	1	0	X	X
Program 4 KB LDROM	1	0001	1	0	Address in	Data in
Read 4 KB LDROM	1	0000	0	0	Address in	Data out

Preliminary W78E365



In-System Programming Control Register (CHPCON)

CHPCON (BFH)

BIT	NAME	FUNCTION
7	SWRESET (F04KMODE)	When this bit is set to 1, and both FBOOTSL and FPROGEN are set to 1. It will enforce microcontroller reset to initial condition just like power on reset. This action will re-boot the microcontroller and start to normal operation. To read this bit in logic-1 can determine that the F04KBOOT mode is running.
6	-	Reserve.
5	-	Reserve.
4	ENAUSTRAM	1: Enable on-chip AUX-RAM. 0: Disable the on-chip AUX-RAM
3	0	must set to 0.
2	0	must set to 0.
1	FBOOTSL	The Program Location Select. 0: The Loader Program locates at the 64 KB APROM. 4 KB LDROM is destination for re-programming. 1: The Loader Program locates at the 4 KB memory bank. 64 KB APROM is destination for re-programming.
0	FPROGEN	FLASH EPROM Programming Enable. = 1:enable. The microcontroller enter the in-system programming mode after entering the idle mode and wake-up from interrupt. During in-system programming mode, the operation of erase, program and read are achieved when device enters idle mode. = 0 0:disable. The on-chip flash memory is read-only. In-system programmability is disabled.

F04KBOOT Mode (Boot From LDROM)

By default, the W78E365 boots from APROM program after a power on reset. On some occasions, user can force the W78E365 to boot from the LDROM program via following settings. The possible situation that you need to enter F04KBOOT mode is when the APROM program can not run properly and device can not jump back to LDROM to execute in-system programming function. Then you can use this F04KBOOT mode to force the W78E365 jumps to LDROM and executes in-system programming procedure. When you design your system, you may reserve the pins P2.6, P2.7 to switches or jumpers. For example in a CD-ROM system, you can connect the P2.6 and P2.7 to PLAY and EJECT buttons on the panel. When the APROM program fails to execute the normal application program. User can press both two buttons at the same time and then turn on the power of the personal computer to force the W78E365 to enter the F04KBOOT mode. After power on of personal computer, you can release both buttons and finish the in-system programming procedure to update the APROM code. In application system design, user must take care of the P2, P3, ALE, \overline{EA} and \overline{PSEN} pin value at reset to prevent from accidentally activating the programming mode or F04KBOOT mode.



F04KBOOT MODE

P4.3	P2.7	P2.6	Mode
X	L	L	FO4KBOOT
L	X	X	FO4KBOOT

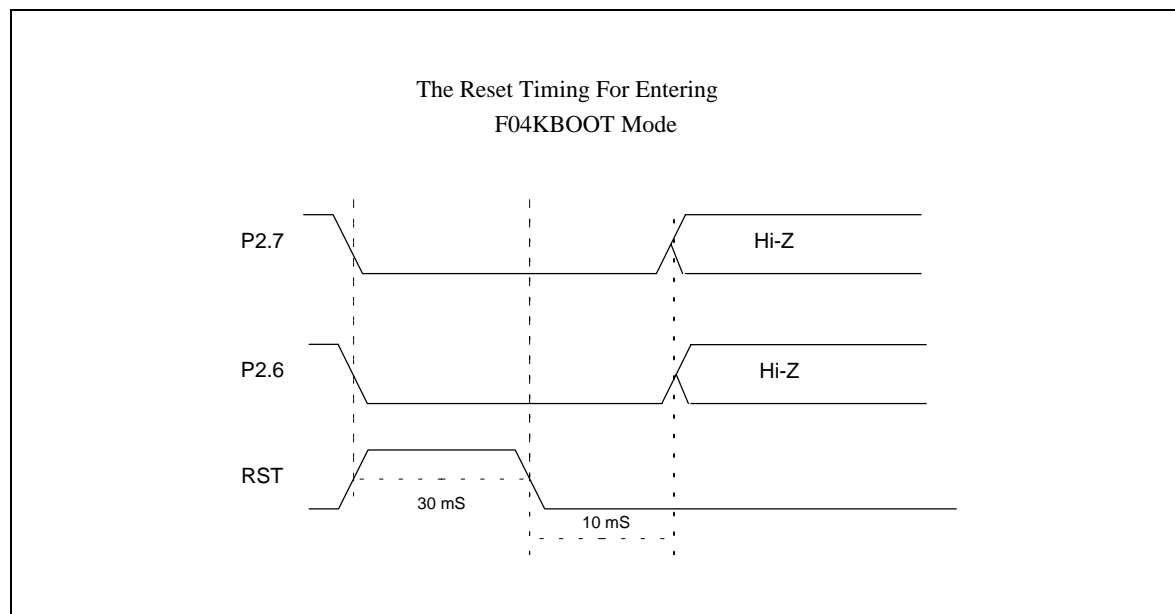



The Algorithm of In-System Programming

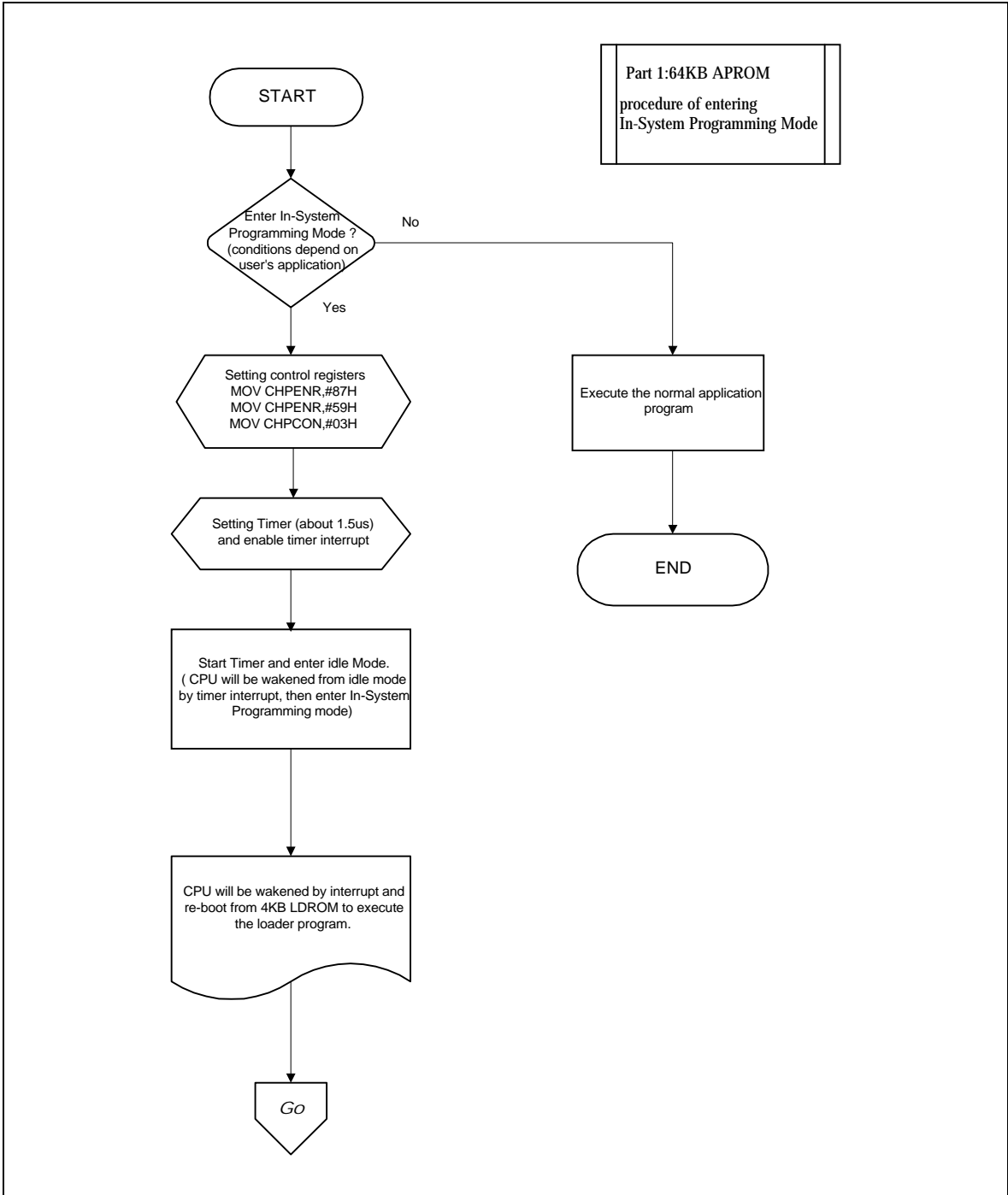

Preliminary W78E365

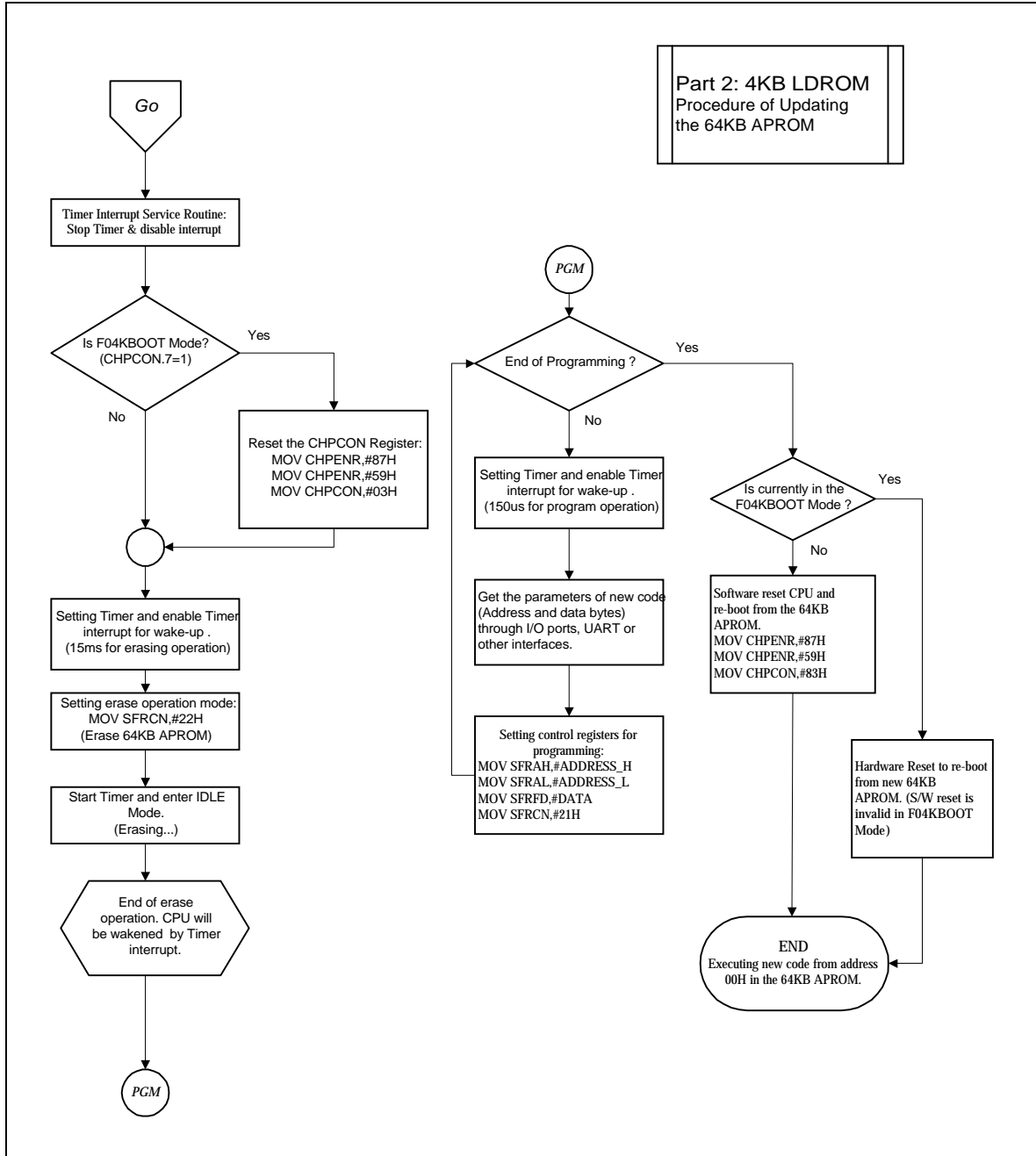

Preliminary W78E365



Security

During the on-chip FLASH EPROM programming mode, the FLASH EPROM can be programmed and verified repeatedly. Until the code inside the FLASH EPROM is confirmed OK, the code can be protected. The protection of FLASH EPROM and those operations on it are described below.

The W78E365 has several Special Setting Registers, including the Security Register and Company/Device ID Registers, which can not be accessed in programming mode. Those bits of the Security Registers can not be changed once they have been programmed from high to low. They can only be reset through erase-all operation. The contents of the Company ID and Device ID registers have been set in factory. **The Security Register is located at the 0FFFFh of the LDROM space.**

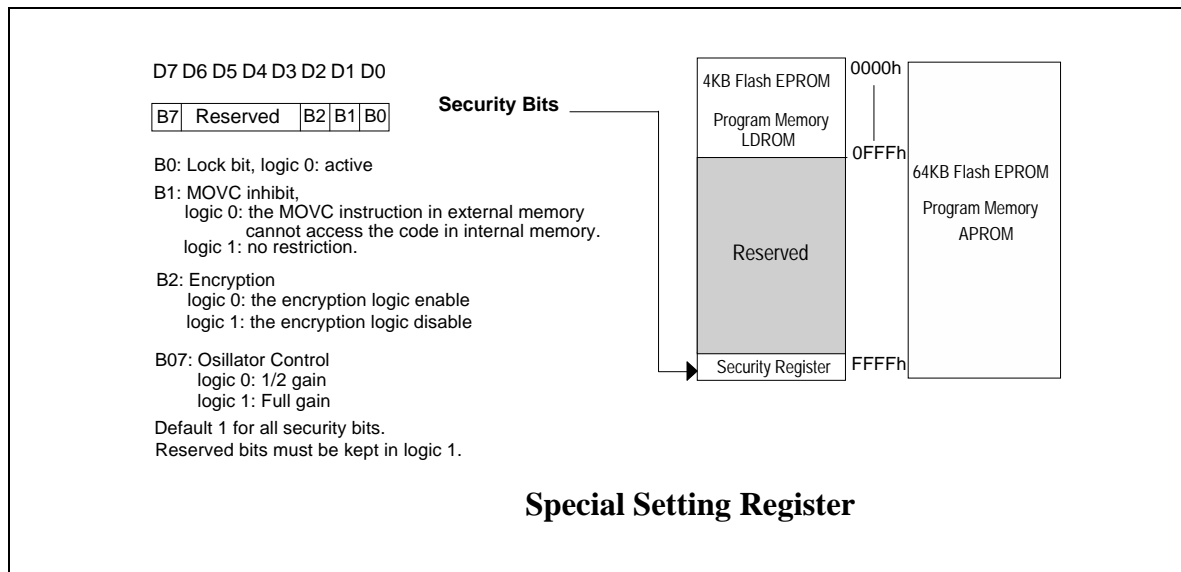

Lock bit

This bit is used to protect the customer's program code in the W78E365. It may be set after the programmer finishes the programming and verifies sequence. Once this bit is set to logic 0, both the FLASH EPROM ROM data and Special Setting Registers can not be accessed again.

MOVC Inhibit

This bit is used to restrict the accessible region of the MOVC instruction. It can prevent the MOVC instruction in external program memory from reading the internal program code. When this bit is set to logic 0, a MOVC instruction in external program memory space will be able to access code only in the external memory, not in the internal memory. A MOVC instruction in internal program memory space will always be able to access the ROM data in both internal and external memory. If this bit is logic 1, there are no restrictions on the MOVC instruction.

Preliminary W78E365



Encryption

This bit is used to enable/disable the encryption logic for code protection. Once encryption feature is enabled, the data presented on port 0 will be encoded via encryption logic. Only whole chip erase will reset this bit.

Oscillator Control

W78E365 allow user to diminish the gain of on-chip oscillator amplifier by using programmer to set the bit B7 of security register. Once B7 is set to 0, a half of gain will be decreased. Care must be taken if user attempts to diminish the gain of oscillator amplifier, reducing a half of gain may improperly affect the external crystal operation at high frequency above 24 MHz. The value of R and C1,C2 may need some adjustment while running at lower gain.

ABSOLUTE MAXIMUM RATINGS

ITEM	SYMBOL	PARAMETER	MIN.	MAX.	UNIT
1	VDD-VSS	DC Power Supply	-0.3	+6.0	V
2	VIN	Input Voltage	VSS -0.3	VDD +0.3	V
3	TA	Operating Temperature	0	70	°C
4	TST	Storage Temperature	-55	+150	°C

Note: Exposure to conditions beyond those listed under Absolute Maximum Ratings may adversely affect the life and reliability of the device.

D.C. ELECTRICAL CHARACTERISTICS

(VDD-VSS = 5V±10%, TA = 25 °C, Fosc = 20 MHz, unless otherwise specified.)

SYMBOL	PARAMETER	SPECIFICATION			TEST CONDITIONS
		MIN.	MAX.	UNIT	
VDD	Operating Voltage	4.5	5.5	V	RST = 1, P0 = VDD
IDD	Operating Current	-	20	mA	No load VDD = 5.5V
IIDLE	Idle Current	-	6	mA	Idle mode VDD = 5.5V
IPWDN	Power Down Current	-	50	μA	Power-down mode VDD = 5.5V
IIN1	Input Current P1, P2, P3, P4	-50	+10	μA	VDD = 5.5V VIN = 0V or VDD
IIN2	Input Current RST	-10	+300	μA	VDD = 5.5V 0 < VIN < VDD

Preliminary W78E365



D.C. Electrical characteristics, continued

SYMBOL	PARAMETER	SPECIFICATION			TEST CONDITIONS
		MIN.	MAX.	UNIT	
VIL1	Input Low Voltage P0, P1, P2, P3, P4, \overline{EA}	0	0.8	V	VDD = 4.5V
VIL2	Input Low Voltage RST	0	0.8	V	VDD = 4.5V
VIL3	Input Low Voltage XTAL1 ^[*4]	0	0.8	V	VDD = 4.5V
VIH1	Input High Voltage P0, P1, P2, P3, P4, \overline{EA}	2.4	VDD+0.2	V	VDD = 5.5V
VIH2	Input High Voltage RST	3.5	VDD+0.2	V	VDD = 5.5V
VIH3	Input High Voltage XTAL1 ^[*4]	3.5	VDD+0.2	V	VDD = 5.5V
VOL1	Output Low Voltage P1, P2, P3, P4	-	0.45	V	VDD = 4.5V IOL = +2 mA
VOL2	Output Low Voltage P0, ALE, \overline{PSEN} ^[*3]	-	0.45	V	VDD = 4.5V IOL = +4 mA
Isk1	Sink current P1, P3, P4	4	12	mA	VDD = 4.5V Vin = 0.45V
Isk2	Sink current P0, P2, ALE, \overline{PSEN}	10	20	mA	VDD = 4.5V Vin = 0.45V
VOH1	Output High Voltage P1, P2, P3, P4	2.4	-	V	VDD = 4.5V IOH = -100 μ A
VOH2	Output High Voltage P0, ALE, \overline{PSEN} ^[*3]	2.4	-	V	VDD = 4.5V IOH = -400 μ A
Isr1	Source current P1, P2, P3, P4	-120	-250	μ A	VDD = 4.5V Vin = 2.4V
Isr2	Source current P0, P2, ALE, \overline{PSEN}	-8	-20	mA	VDD = 4.5V Vin = 2.4V

Notes:

*1. RST pin is a Schmitt trigger input.

*3. P0, ALE and \overline{PSEN} are tested in the external access mode.

*4. XTAL1 is a CMOS input.

*5. Pins of P1, P2, P3, P4 can source a transition current when they are being externally driven from 1 to 0. The transition current reaches its maximum value when V_{IN} approximates to 2V.

Publication Release Date: April 2001

Revision A1



AC CHARACTERISTICS

The AC specifications are a function of the particular process used to manufacture the part, the ratings of the I/O buffers, the capacitive load, and the internal routing capacitance. Most of the specifications can be expressed in terms of multiple input clock periods (TCP), and actual parts will usually experience less than a ± 20 nS variation. The numbers below represent the performance expected from a 0.6 micron CMOS process when using 2 and 4 mA output buffers.

Clock Input Waveform

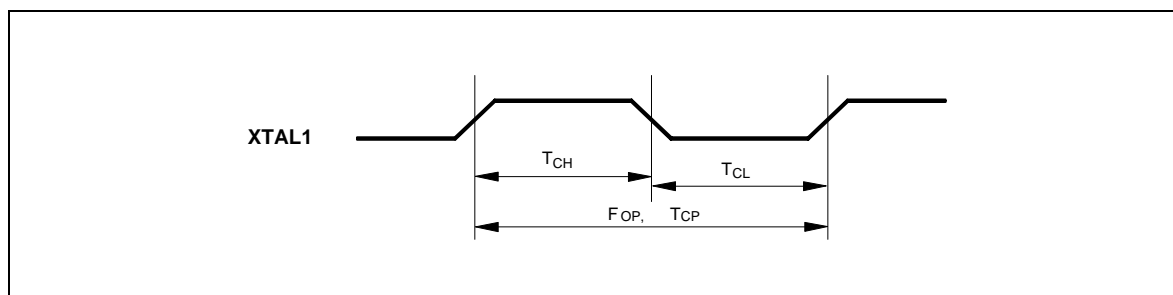

PARAMETER	SYMBOL	MIN.	TYP.	MAX.	UNIT	NOTES
Operating Speed	FOP	0	-	40	MHz	1
Clock Period	TCP	25	-	-	nS	2
Clock High	TCH	10	-	-	nS	3
Clock Low	TCL	10	-	-	nS	3

Notes:

1. The clock may be stopped indefinitely in either state.
2. The TCP specification is used as a reference in other specifications.
3. There are no duty cycle requirements on the XTAL1 input.

Preliminary W78E365



Program Fetch Cycle

PARAMETER	SYMBOL	MIN.	TYP.	MAX.	UNIT	NOTES
Address Valid to ALE Low	TAAS	1 T _{CP} -Δ	-	-	nS	4
Address Hold from ALE Low	TAAH	1 T _{CP} -Δ	-	-	nS	1, 4
ALE Low to $\overline{\text{PSEN}}$ Low	TAPL	1 T _{CP} -Δ	-	-	nS	4
$\overline{\text{PSEN}}$ Low to Data Valid	TPDA	-	-	2 T _{CP}	nS	2
Data Hold after $\overline{\text{PSEN}}$ High	TPDH	0	-	1 T _{CP}	nS	3
Data Float after $\overline{\text{PSEN}}$ High	TPDZ	0	-	1 T _{CP}	nS	
ALE Pulse Width	TALW	2 T _{CP} -Δ	2 T _{CP}	-	nS	4
$\overline{\text{PSEN}}$ Pulse Width	TPSW	3 T _{CP} -Δ	3 T _{CP}	-	nS	4

Notes:

1. P0.0–P0.7, P2.0–P2.7 remain stable throughout entire memory cycle.
2. Memory access time is 3 T_{CP}.
3. Data have been latched internally prior to $\overline{\text{PSEN}}$ going high.
4. "Δ" (due to buffer driving delay and wire loading) is 20 nS.

Data Read Cycle

PARAMETER	SYMBOL	MIN.	TYP.	MAX.	UNIT	NOTES
ALE Low to $\overline{\text{RD}}$ Low	TDAR	3 T _{CP} -Δ	-	3 T _{CP} +Δ	nS	1, 2
$\overline{\text{RD}}$ Low to Data Valid	TDDA	-	-	4 T _{CP}	nS	1
Data Hold from $\overline{\text{RD}}$ High	TDDH	0	-	2 T _{CP}	nS	
Data Float from $\overline{\text{RD}}$ High	TDDZ	0	-	2 T _{CP}	nS	
$\overline{\text{RD}}$ Pulse Width	TDRD	6 T _{CP} -Δ	6 T _{CP}	-	nS	2

Notes:

1. Data memory access time is 8 T_{CP}.
2. "Δ" (due to buffer driving delay and wire loading) is 20 nS.

Preliminary W78E365



Data Write Cycle

ITEM	SYMBOL	MIN.	TYP.	MAX.	UNIT
ALE Low to \overline{WR} Low	TDAW	3 $T_{CP-\Delta}$	-	3 $T_{CP+\Delta}$	nS
Data Valid to \overline{WR} Low	TDAD	1 $T_{CP-\Delta}$	-	-	nS
Data Hold from \overline{WR} High	TDWD	1 $T_{CP-\Delta}$	-	-	nS
\overline{WR} Pulse Width	TDWR	6 $T_{CP-\Delta}$	6 T_{CP}	-	nS

Note: " Δ " (due to buffer driving delay and wire loading) is 20 nS.

Port Access Cycle

PARAMETER	SYMBOL	MIN.	TYP.	MAX.	UNIT
Port Input Setup to ALE Low	TPDS	1 T_{CP}	-	-	nS
Port Input Hold from ALE Low	TPDH	0	-	-	nS
Port Output to ALE	TPDA	1 T_{CP}	-	-	nS

Note: Ports are read during S5P2, and output data becomes available at the end of S6P2. The timing data are referenced to ALE, since it provides a convenient reference.

TIMING WAVEFORMS

Program Fetch Cycle

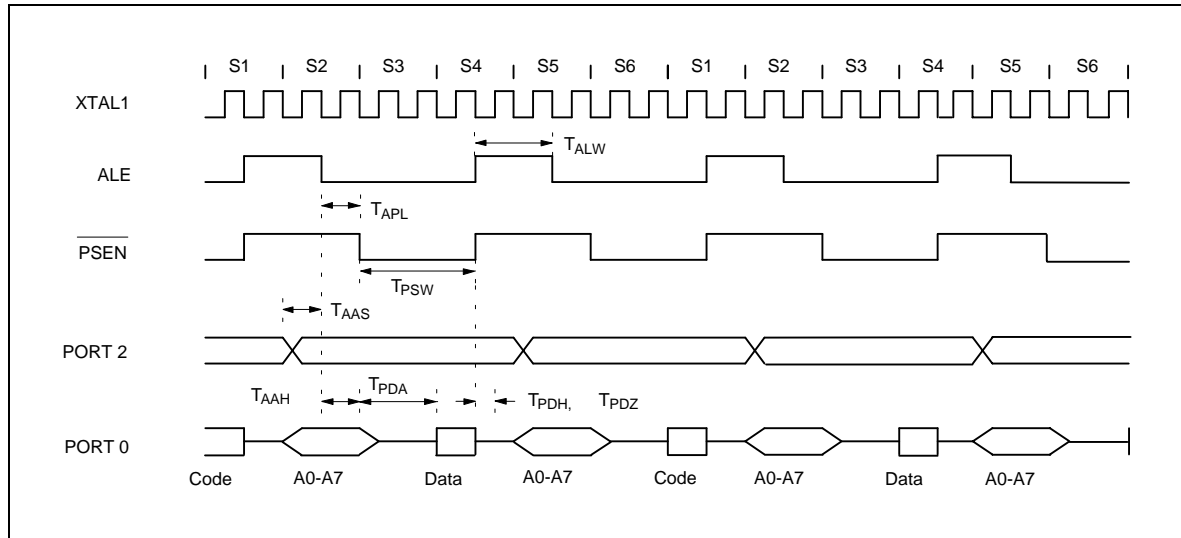

Preliminary W78E365



Data Read Cycle

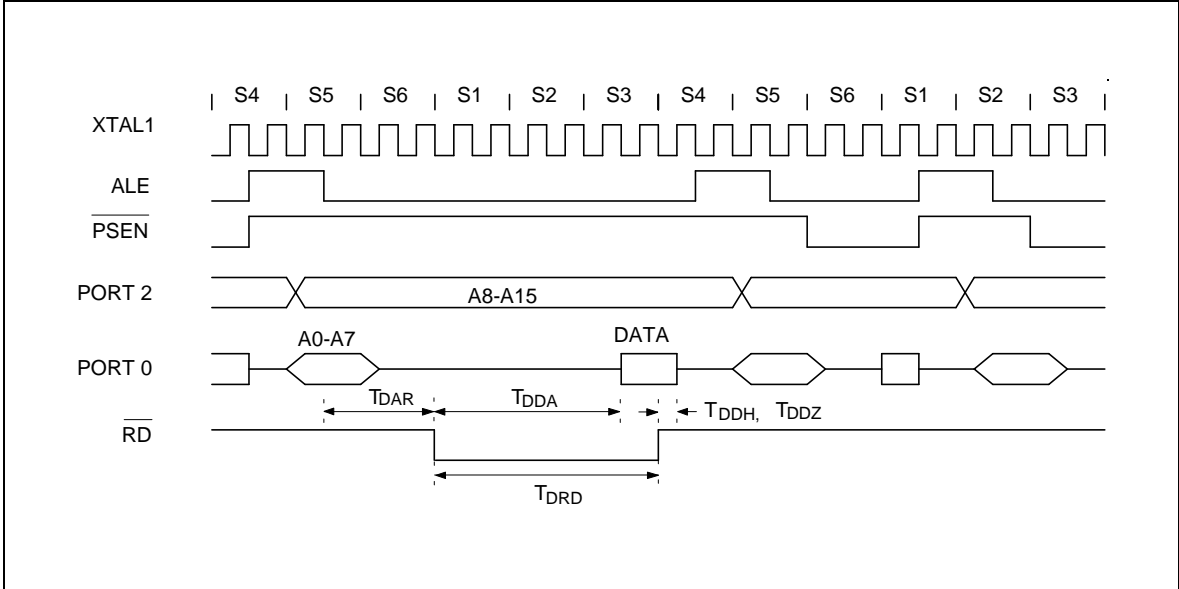

Data Write Cycle

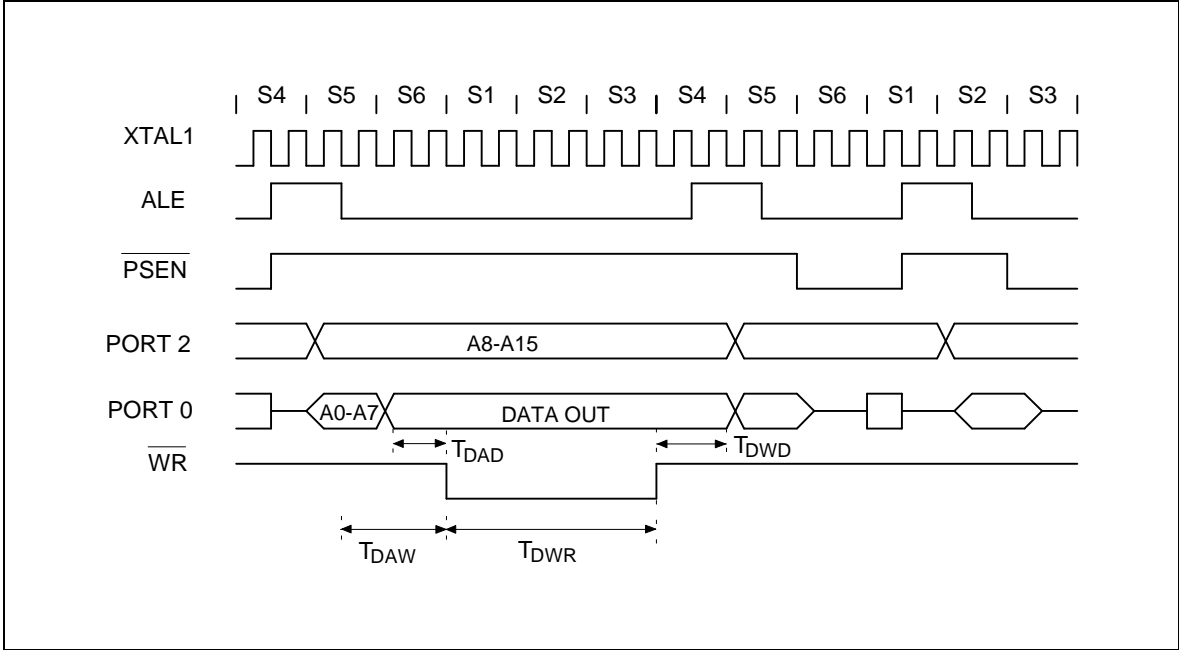



Port Access Cycle

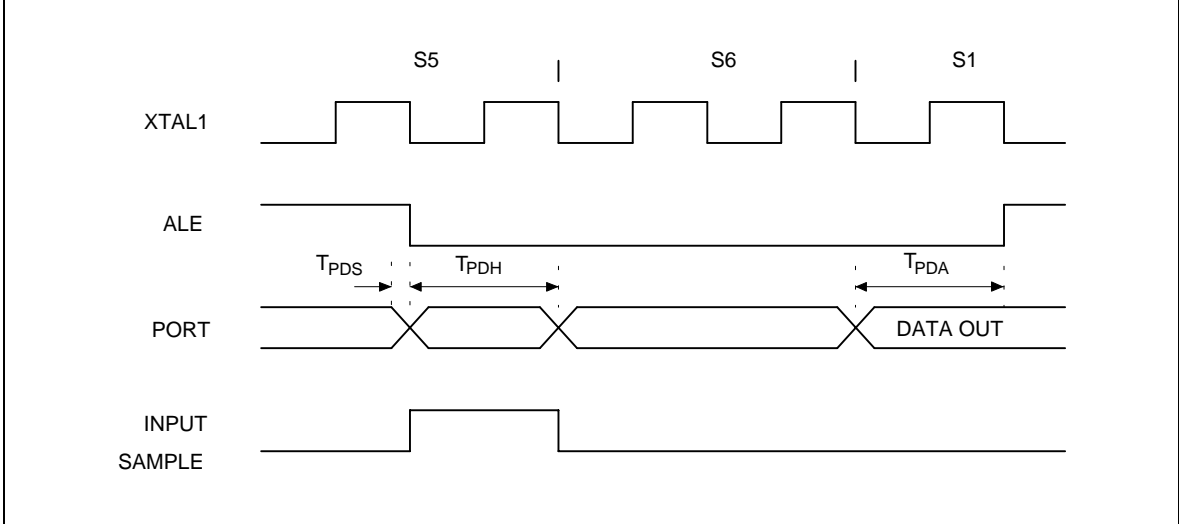

Preliminary W78E365



TYPICAL APPLICATION CIRCUIT

Expanded External Program Memory and Crystal

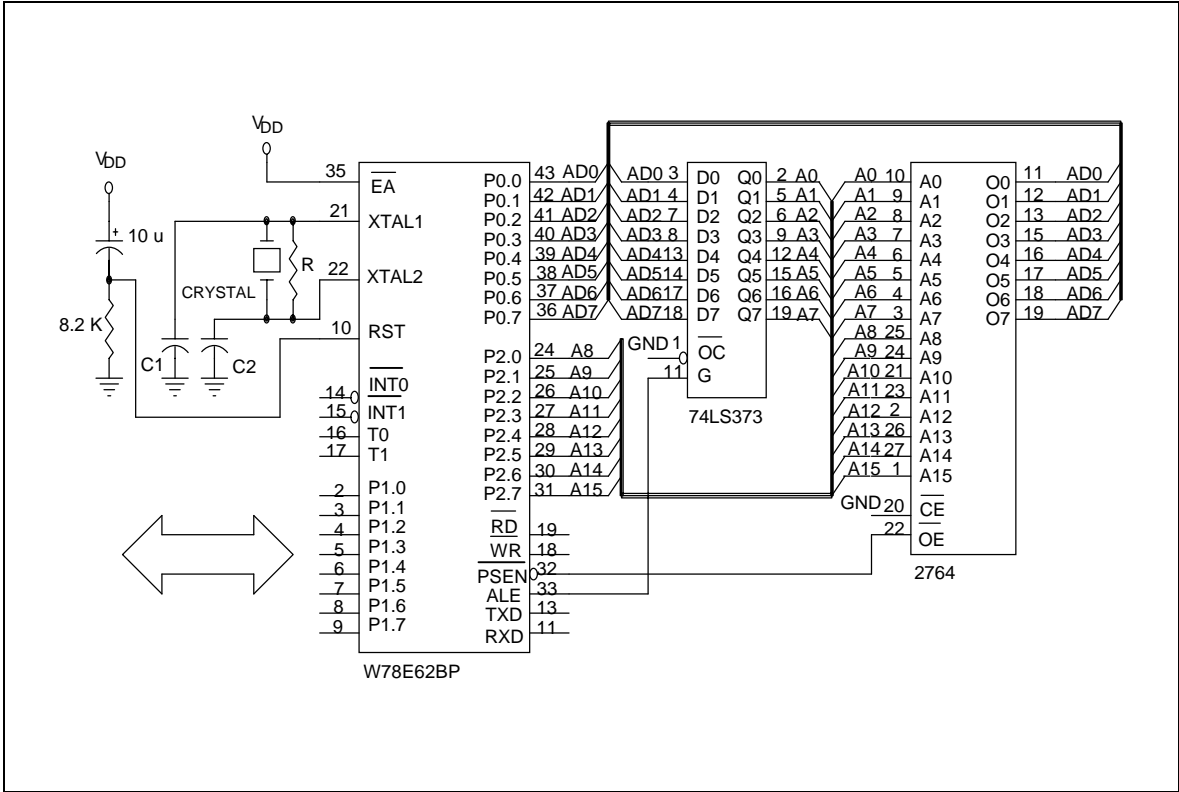

Figure A

CRYSTAL	C1	C2	R
6 MHz	47P	47P	-
16 MHz	30P	30P	-
24 MHz	15P	10P	-
32 MHz	10P	10P	6.8K
40 MHz	5P	5P	4.7K

Above table shows the reference values for crystal applications.

Note1: C1, C2, R components refer to Figure A

Note2: Crystal layout must get close to XTAL1 and XTAL2 pins on user's application board.

Preliminary W78E365



Expanded External Data Memory and Oscillator

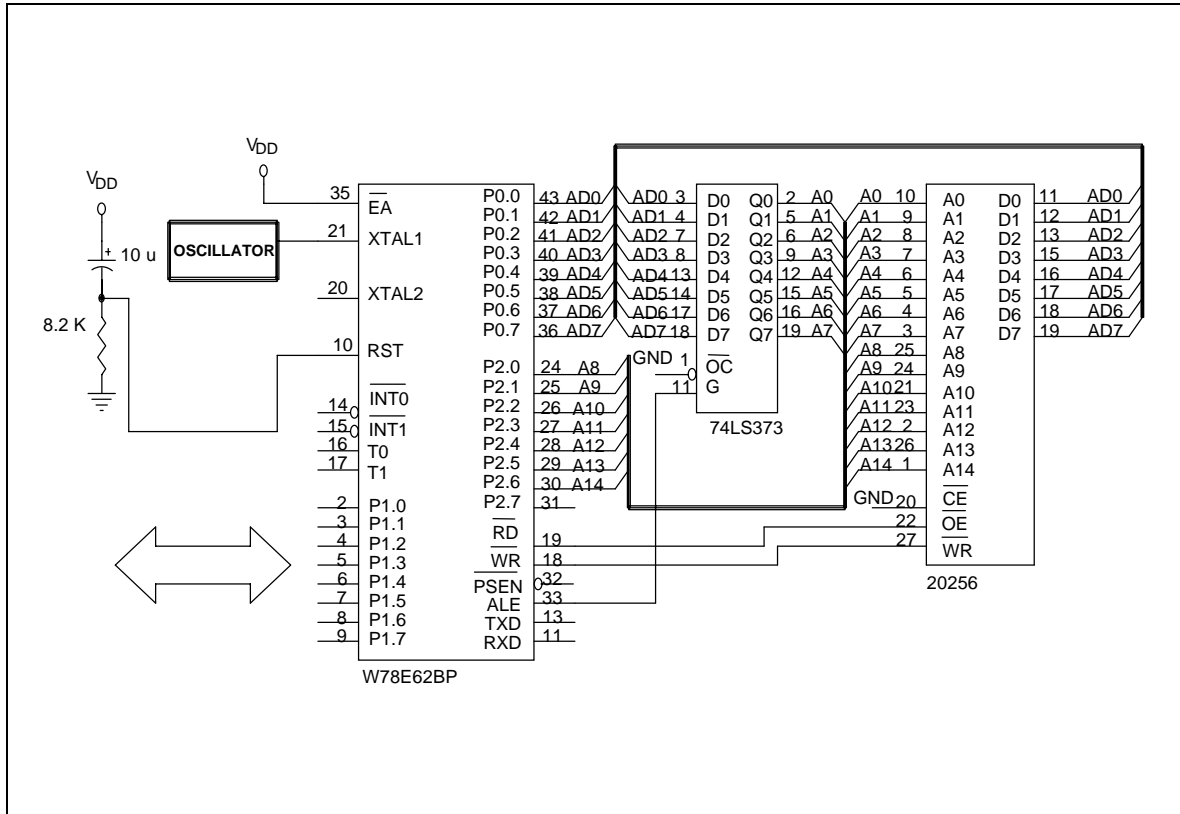

Figure B

Preliminary W78E365



PACKAGE DIMENSIONS

44-pin PLCC

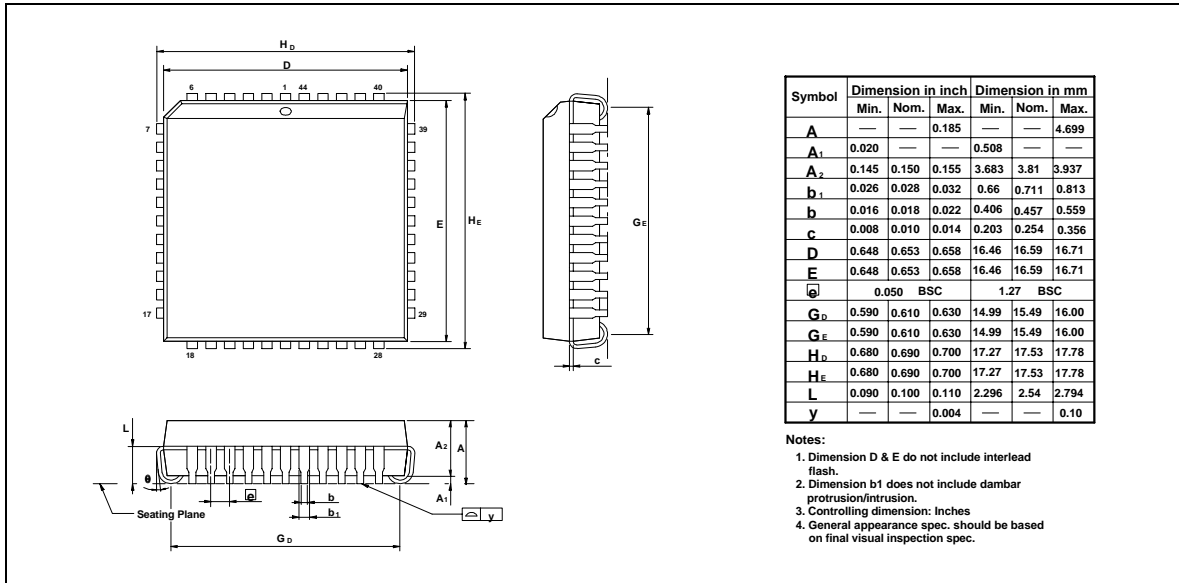

48-pin LQFP

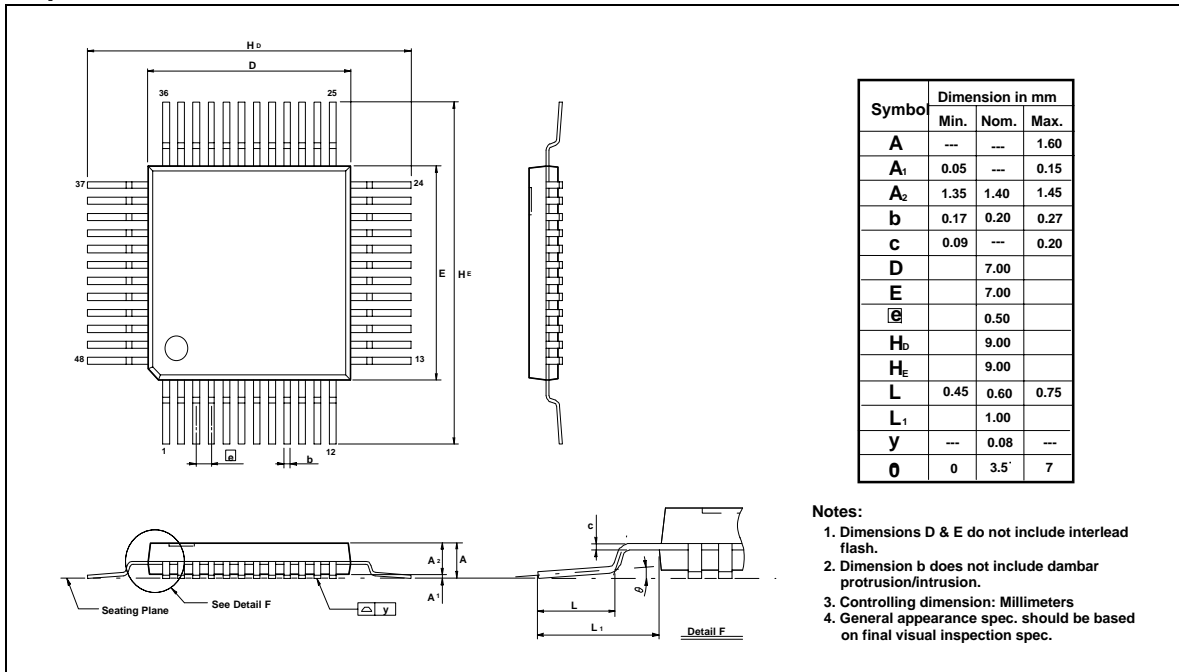



Application Note: In-system Programming Software Examples

This application note illustrates the in-system programmability of the Winbond W78E365 FLASH EPROM microcontroller. In this example, microcontroller will boot from 64KB APROM bank and waiting for a key to enter in-system programming mode for re-programming the contents of 64KB APROM. While entering in-system programming mode, microcontroller excutes the loader program in 4KB LDROM bank. The loader program erases the 64KB APROM then reads the new code data from external SRAM buffer (or through other interfaces) to update the 64KB APROM.

EXAMPLE 1:

```

*****
;
;* Example of 64K APROM program: Program will scan the P1.0. if P1.0 = 0, enters in-system
;* programming mode for updating thecontents of APROM code else excutes the current ROM code.
;* XTAL = 40 MHz
;
*****

.chip 8052
.RAMCHK OFF
.symbols

CHPCON      EQU      BFH
CHPENR      EQU      F6H
SFRAL       EQU      C4H
SFRAH       EQU      C5H
SFRFD       EQU      C6H
SFRCN       EQU      C7H

      ORG      0H
      LJMP    100H      ;JUMP TO MAIN PROGRAM
*****
;* TIMER0 SERVICE VECTOR ORG = 000BH
;
      ORG      00BH
      CLR     TR0      ;TR0 = 0,STOP TIMER0
      MOV     TL0,R6
      MOV     TH0,R7
      RETI
*****
;* 64K APROM MAIN PROGRAM
;
      ORG      100H

MAIN_64K:

      MOV A,P1          ;SCAN P1.0
      ANL A,#01H
      CJNE A,#01H,PROGRAM_64K ;IF P1.0=0, ENTER IN-SYSTEM PROGRAMMING MODE
      JMP NORMAL_MODE

```

Preliminary W78E365



```
PROGRAM_64K:
    MOV CHPENR,#87H    ;CHPENR = 87H, CHPCON REGISTER WRTE ENABLE
    MOV CHPENR,#59H    ;CHPENR = 59H, CHPCON REGISTER WRITE ENABLE
    MOV CHPCON,#03H    ;CHPCON = 03H, ENTER IN-SYSTEM PROGRAMMING MODE
    MOV TCON,#00H      ;TR = 0 TIMER0 STOP
    MOV IP,#00H        ;IP = 00H
    MOV IE,#82H        ;TIMER0 INTERRUPT ENABLE FOR WAKE-UP FROM IDLE MODE
    MOV R6,#FEH        ;TL0 = FEH
    MOV R7,#FFH        ;TH0 = FFH
    MOV TL0,R6
    MOV TH0,R7
    MOV TMOD,#01H      ;TMOD = 01H,SET TIMER0 A 16-BIT TIMER
    MOV TCON,#10H      ;TCON = 10H,TR0 = 1,GO
    MOV PCON,#01H      ;ENTER IDLE MODE FOR LAUNCHING THE IN-SYSTEM
                        ;PROGRAMMABILITY
```

```
.*****
;
;* Normal mode 64KB APROM program: depending user's application
.*****
```

```
NORMAL_MODE:
    .                    ;User's application program
    .
    .
    .
    .
```

EXAMPLE 2:

```
.*****
;
Example of 4KB LDROM program: This loader program will erase the 64KB APROM first, then reads the new
code from external SRAM and program them into 64KB APROM bank. XTAL = 40 MHz
.*****
```

```
.chip 8052
.RAMCHK OFF
.symbols
```

```
    CHPCON    EQU    BFH
    CHPENR    EQU    F6H
    SFRAL     EQU    C4H
    SFRAH     EQU    C5H
    SFRFD     EQU    C6H
    SFRCN     EQU    C7H

    ORG       000H
    LJMP      100H    ;JUMP TO MAIN PROGRAM
```

```
.*****
;
;* 1. TIMER0 SERVICE VECTOR ORG = 0BH
.*****
;
    ORG 000BH
    CLR TR0          ;TR0 = 0,STOP TIMER0
    MOV TL0,R6
    MOV TH0,R7
    RETI
```

Preliminary W78E365



```
*****
;
;* 4KB LDROM MAIN PROGRAM
;*****
      ORG 100H
```

MAIN_4K:

```
      MOV CHPENR,#87H      ;CHPENR = 87H, CHPCON WRITE ENABLE.
      MOV CHPENR,#59H      ;CHPENR = 59H, CHPCON WRITE ENABLE.
      MOV A,CHPCON
      ANL A,#80H
      CJNE A,#80H,UPDATE_64K ;CHECK F04KBOOT MODE ?

      MOV CHPCON,#03H      ;CHPCON = 03H, ENABLE IN-SYSTEM PROGRAMMING.
      MOV CHPENR,#00H      ;DISABLE CHPCON WRITE ATTRIBUTE

      MOV TCON,#00H        ;TCON = 00H ,TR = 0 TIMER0 STOP
      MOV TMOD,#01H        ;TMOD = 01H ,SET TIMER0 A 16BIT TIMER
      MOV IP,#00H          ;IP = 00H
      MOV IE,#82H          ;IE = 82H, TIMER0 INTERRUPT ENABLED
      MOV R6,#FEH
      MOV R7,#FFH
      MOV TL0,R6
      MOV TH0,R7
      MOV TCON,#10H        ;TCON = 10H,TR0 = 1,GO
      MOV PCON,#01H        ;ENTER IDLE MODE
```

UPDATE_64K:

```
      MOV CHPENR,#00H      ;DISABLE CHPCON WRITE-ATTRIBUTE
      MOV TCON,#00H        ;TCON = 00H ,TR = 0 TIM0 STOP
      MOV IP,#00H          ;IP = 00H
      MOV IE,#82H          ;IE = 82H,TIMER0 INTERRUPT ENABLED
      MOV TMOD,#01H        ;TMOD = 01H ,MODE1
      MOV R6,#3CH          ;SET WAKE-UP TIME FOR ERASE OPERATION, ABOUT 15ms.
                           ;DEPENDING
```

;ON USER'S SYSTEM CLOCK RATE.

```
      MOV R7,#B0H
      MOV TL0,R6
      MOV TH0,R7
```

ERASE_P_4K:

```
      MOV SFRCN,#22H      ;SFRCN(C7H) = 22H ERASE 64K
      MOV TCON,#10H        ;TCON = 10H,TR0 = 1,GO
      MOV PCON,#01H        ;ENTER IDLE MODE( FOR ERASE OPERATION)
```

Preliminary W78E365



```
*****
;
;* BLANK CHECK
*****
;
MOV SFRCN,#0H      ;READ 64KB APROM MODE
MOV SFRAH,#0H      ;START ADDRESS = 0H
MOV SFRAL,#0H
MOV R6,#FBH        ;SET TIMER FOR READ OPERATION, ABOUT 1.5us.
MOV R7,#FFH
MOV TL0,R6
MOV TH0,R7
```

BLANK_CHECK_LOOP:

```
SETB TR0          ;ENABLE TIMER 0
MOV PCON,#01H     ;ENTER IDLE MODE
MOV A,SFRFD       ;READ ONE BYTE

CJNE A,#FFH,BLANK_CHECK_ERROR
INC SFRAL         ;NEXT ADDRESS
MOV A,SFRAL
JNZ BLANK_CHECK_LOOP
INC SFRAH
MOV A,SFRAH
CJNE A,#0H,BLANK_CHECK_LOOP ;END ADDRESS=FFFFH
JMP PROGRAM_64KROM
```

BLANK_CHECK_ERROR:

```
MOV P1,#F0H
MOV P3,#F0H
JMP $
```

```
*****
;
;* RE-PROGRAMMING 64KB APROM BANK
*****
;
PROGRAM_64KROM:
```

```
MOV DPTR,#0H      ;THE ADDRESS OF NEW ROM CODE
MOV R2,#00H       ;TARGET LOW BYTE ADDRESS
MOV R1,#00H       ;TARGET HIGH BYTE ADDRESS

MOV DPTR,#0H      ;EXTERNAL SRAM BUFFER ADDRESS
MOV SFRAH,R1      ;SFRAH, TARGET HIGH ADDRESS
MOV SFRCN,#21H    ;SFRCN(C7H) = 21 (PROGRAM 64K)
MOV R6,#0CH       ;SET TIMER FOR PROGRAMMING, ABOUT 150us.
MOV R7,#FEH
MOV TL0,R6
MOV TH0,R7
```

Publication Release Date: April 2001

Preliminary W78E365



```
PROG_D_64K:
    MOV SFRAL,R2          ;SFRAL(C4H)= LOW BYTE ADDRESS
    MOVX A,@DPTR         ;READ DATA FROM EXTERNAL SRAM BUFFER
    MOV SFRFD,A          ;SFRFD(C6H) = DATA IN
    MOV TCON,#10H        ;TCON = 10H,TR0 = 1,GO
    MOV PCON,#01H        ;ENTER IDLE MODE( PRORGAMMING)
    INC DPTR
    INC R2
    CJNE R2,#0H,PROG_D_64K
    INC R1
    MOV SFRAH,R1
    CJNE R1,#0H,PROG_D_64K
;*****
;
;* VERIFY 64KB APROM BANK
;*****
    MOV R4,#03H          ;ERROR COUNTER
    MOV R6,#FBH          ;SET TIMER FOR READ VERIFY, ABOUT 1.5us.
    MOV R7,#FFH
    MOV TL0,R6
    MOV TH0,R7
    MOV DPTR,#0H         ;The start address of sample code
    MOV R2,#0H           ;Target low byte address
    MOV R1,#0H           ;Target high byte address
    MOV SFRAH,R1         ;SFRAH, Target high address
    MOV SFRCN,#00H       ;SFRCN = 00 (Read ROM CODE)
READ_VERIFY_64K:
    MOV SFRAL,R2          ;SFRAL(C4H) = LOW ADDRESS
    MOV TCON,#10H        ;TCON = 10H,TR0 = 1,GO
    MOV PCON,#01H
    INC R2
    MOVX A,@DPTR
    INC DPTR
    CJNE A,SFRFD,ERROR_64K
    CJNE R2,#0H,READ_VERIFY_64K
    INC R1
    MOV SFRAH,R1
    CJNE R1,#0H,READ_VERIFY_64K
;*****
;
;* PROGRAMMING COMPLETLY, SOFTWARE RESET CPU
;*****
    MOV CHPENR,#87H      ;CHPENR = 87H
    MOV CHPENR,#59H      ;CHPENR = 59H
    MOV CHPCON,#83H      ;CHPCON = 83H, SOFTWARE RESET.

ERROR_64K:
    DJNZ R4,UPDATE_64K  ;IF ERROR OCCURS, REPEAT 3 TIMES.
    .                   ;IN-SYSTEM PROGRAMMING FAIL, USER'S PROCESS TO DEAL WITH IT.
    .
    .
    .
    .
```

Preliminary W78E365



Headquarters

No. 4, Creation Rd. III,
Science-Based Industrial Park,
Hsinchu, Taiwan
TEL: 886-3-5770066
FAX: 886-3-5792766
<http://www.winbond.com.tw/>
Voice & Fax-on-demand: 886-2-27197006

Taipei Office

11F, No. 115, Sec. 3, Min-Sheng East Rd.,
Taipei, Taiwan
TEL: 886-2-27190505
FAX: 886-2-27197502

Winbond Electronics (H.K.) Ltd.

Rm. 803, World Trade Square, Tower II,
123 Hoi Bun Rd., Kwun Tong,
Kowloon, Hong Kong
TEL: 852-27513100
FAX: 852-27552064

Winbond Electronics North America Corp.

Winbond Memory Lab.
Winbond Microelectronics Corp.
Winbond Systems Lab.
2727 N. First Street, San Jose,
CA 95134, U.S.A.
TEL: 408-9436666
FAX: 408-5441798

Note: All data and specifications are subject to change without notice.