

WAS4759

2.5Ω Dual SPDT Analog Switch with True Isolation in Power-Down Mode, VCC=0

[Http://www.willsemi.com](http://www.willsemi.com)

Descriptions

The WAS4759 is a dual single-pole double-throw (SPDT) analog switch that is designed to operate from a single power supply (+2.3V to +5.5V). The device offers low ON-state resistance and excellent ON-state resistance matching with break-before-make feature, to prevent signal distortion during the transferring of a signal from one channel to another. The device is capable of truly isolation in power-down mode, VCC=0 and signal pins are able to withstand voltage up to 8V. As signal pins' voltage is higher than VCC, very little current will flow back to the supply. These features make this device suitable for isolating Base-Band from independent audio drivers, Class D or K and such circumstance as power-up after signals are being available.

The INx control pin has overvoltage protection that allows voltages above VCC, up to 5.5V to be present on the pin without damage or disruption of operation of the part, regardless of the operating voltage. The WAS4759 is also featured with smart circuitry to minimize VCC leakage current even when INx control voltage is lower than VCC supply voltage.

The WAS4759 is available in QFN2116-10L and QFN1418-10L package. Standard product is Pb-Free and halogen-Free.

Features

- Isolation in Power-Down Mode, VCC=0
- Low ON-State Resistance: **2.5Ω**
- Control Inputs are 5.5V Tolerant
- Signal Inputs are 8.0V Tolerant
- Supply voltage : 2.3 ~ 5.5V
- -3dB Bandwidth : 200MHz @ CL=5pF
- Low quiescent current : <100uA

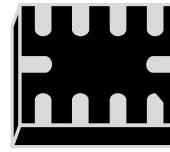

QFN2116-10L

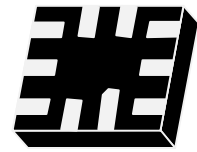

QFN1418-10L

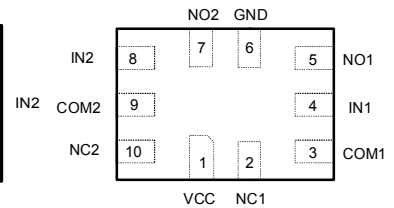
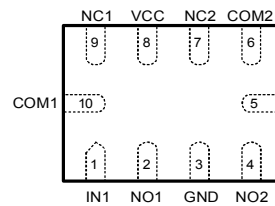

Pin configuration (Top view)

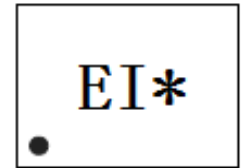

Marking

- | | |
|---------------------------|------------------------|
| 4759 = Device code | EI =Device code |
| QB = Package code | * =Month code |
| Y = Year code | |
| W = Week code | |

Applications

- Cell phones and tablet PC
- Portable Instruments
- Audio and Video Signal Routing

Order information

Device	Package	Shipping
WAS4759QA-10/TR	QFN1418-10L	3000/Reel&Tape
WAS4759QB-10/TR	QFN2116-10L	3000/Reel&Tape

Pin descriptions

QA Pin Number	QB Pin Number	Symbol	Descriptions
4	1	IN1	Switch select pin, 1.8V GPIO compatible
5	2	NO1	Port 1 signal terminal, normally open
6	3	GND	Ground
7	4	NO2	Port 2 signal terminal, normally open
8	5	IN2	Switch select pin, 1.8V GPIO compatible
9	6	COM2	Port 2 common terminal
10	7	NC2	Port 2 signal terminal, normally closed
1	8	VCC	Power Supply
2	9	NC1	Port 1 signal terminal, normally closed
3	10	COM1	Port 1 common terminal

Function descriptions

INx	Function
L	NCx connect to COMx, NOx disconnect to COMx
H	NOx connect to COMx, NCx disconnect to COMx

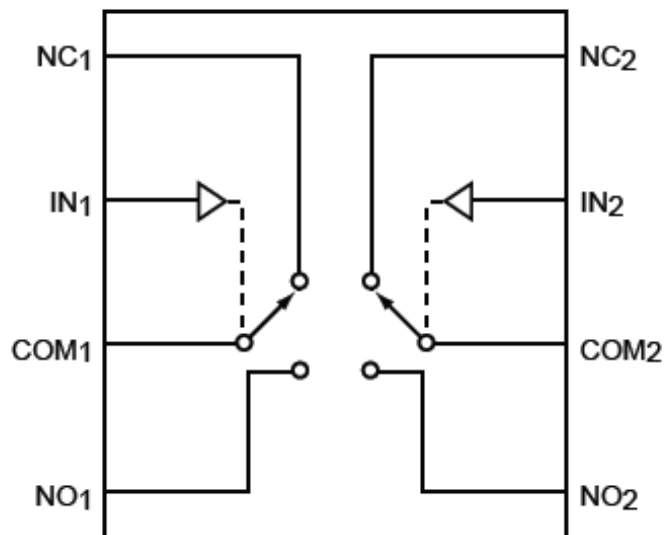
Functional Block Diagram

Absolute maximum ratings

Parameter	Symbol	Value	Unit
Supply voltage range	VCC	-0.5 ~ 6.5	V
Data input/output voltage range	V _{DATA}	-0.5 ~ 6.5	V
Select input voltage range	V _{SEL}	-0.5 ~ 6.5	V
Continues output current	I _{OUT}	±50	mA
Junction temperature range	T _J	150	°C
Lead temperature range	T _L	260	°C
Storage temperature range	T _{STG}	-65 ~ 150	°C
Thermal resistance	R _{θJA}	250	°C/W
ESD protection (HBM)	I/O to VCC, I/O to GND	±4000	V
	I/O to I/O	±4000	V

Recommend operating ratings

Parameter	Symbol	Value	Unit
Supply voltage range	VCC	2.3 ~ 5.5	V
Data input/output voltage range	V _{DATA}	0.0 ~ VCC	V
Select input voltage range	V _{SEL}	0.0 ~ VCC	V
Enable control input voltage range	V _{OE}	0.0 ~ VCC	V
Operating temperature range	T _A	-40 ~ 85	°C

Electronics Characteristics (Ta=25°C, VCC=3.6V, unless otherwise noted)

Parameter	Symbol	Conditions	Min.	Typ.	Max.	Unit
Control logic high level	V _{IH}	VCC=3.0~4.5	1.5			V
		VCC=2.3~3.0	1.4			V
Control logic low level	V _{IL}	VCC=3.0~4.5			0.5	V
		VCC=2.3~3.0			0.4	V
Supply quiescent current	I _{CC}	I _{Nx} =VCC or 0		55		uA
Control input leakage current	I _{INx}	I _{Nx} =VCC			±2.0	uA
COM Off leakage current	I _{COM(PWROFF)}	V _{NO} or V _{NC} =0 to 5.5V V _{COM} =5.5V to 0 VCC=0V, Switch OFF			±2.0	uA
NC, NO Off leakage current	I _{NC(PWROFF)} I _{NO(PWROFF)}	V _{NO} or V _{NC} =5.5V to 0 V _{COM} =0 to 5.5V VCC=0V, Switch OFF			±2.0	uA
On state switch leakage current	I _{ON}	V _{NO} or V _{NC} =Open V _{COM} =0~VCC or V _{NO} or V _{NC} =0~VCC V _{COM} =Open			±1.0	uA
On-Resistance	R _{ON}	V _{NO} or V _{NC} =2.5V I _{COM} =100mA See figure 3		2.5	3.5	Ω
On-Resistance match	Δ R _{ON}	V _{NO} or V _{NC} =2.5V I _{COM} =100mA See figure 3			0.1	Ω
On-Resistance flatness	R _{FLAT(ON)}	0<(V _{NO} or V _{NC})<VCC I _{COM} =100mA See figure 3		0.25		Ω
Turn-on time	T _{ON}	C _L =10pF, R _L =50Ω See figure 5		75	120	ns
Turn-off time	T _{OFF}	C _L =10pF, R _L =50Ω See figure 5		40	80	ns
Break-Before-Make time	T _{BBM}	Guaranteed by design	5			ns
-3dB Bandwidth	BW	R _L =50Ω, C _L =5pF		200		MHz
Off isolation	OIRR	R _L =50Ω, F=1MHz		-70		dB
Crosstalk	Xtalk	R _L =50Ω, F=1MHz		-70		dB
Charge injection (Select input to common I/O)	Q _g	C _L =0.1nF R _G =0Ω, V _G =GND		8		pC
Control input capacitance	C _{IN}			5		pF
NC, NO Off capacitance	C _{OFF}	V _{NO} or V _{NC} =VCC or GND, Switch OFF		19		pF
NC, NO On capacitance	C _{OFF}	V _{NO} or V _{NC} =VCC or GND, Switch ON		50		pF

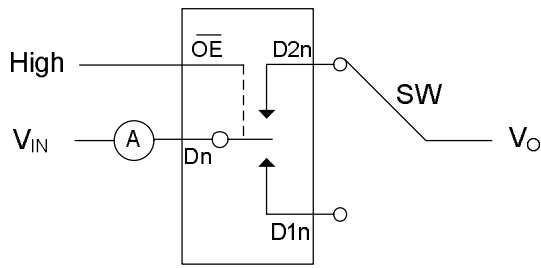
Test Circuit

Conditions: $V_{IN}=4.5V$, $V_O=GND$

Figure 1: Off state switch leakage current

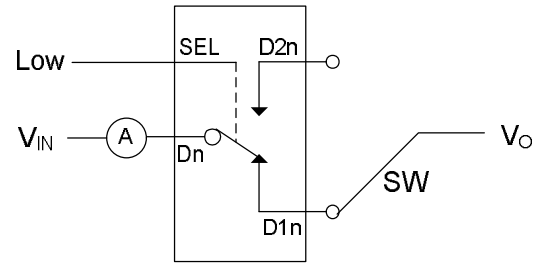

Conditions: $V_{IN}=4.5V$, $V_O=Open$

Figure 2: On state switch leakage current

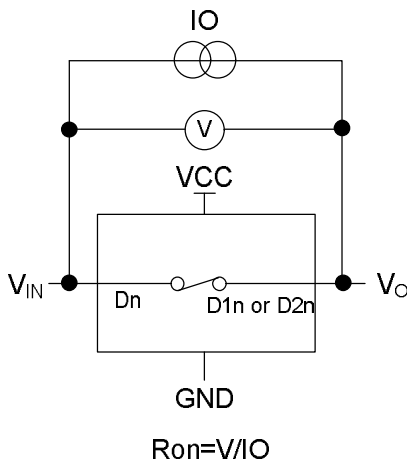

Figure 3: On-Resistance

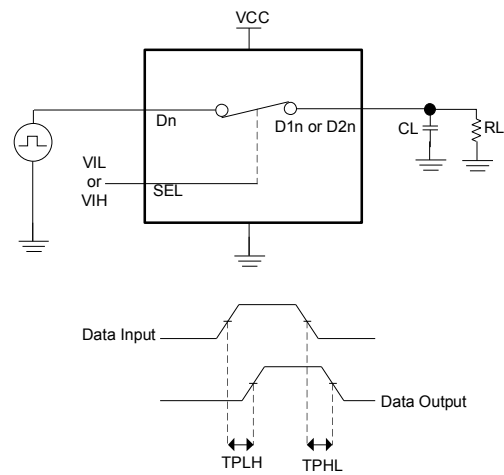

Figure 4: Propagation delay time

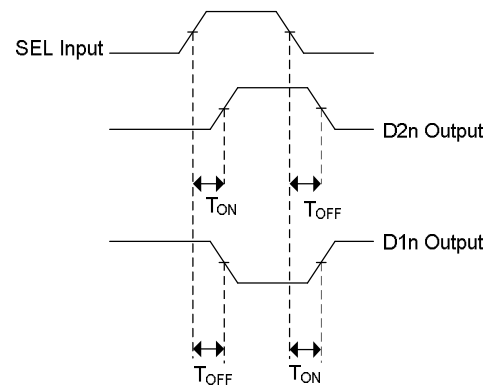
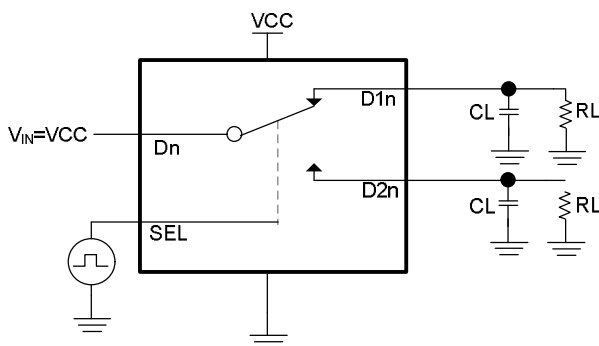
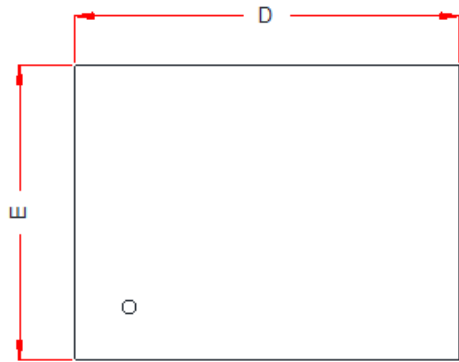
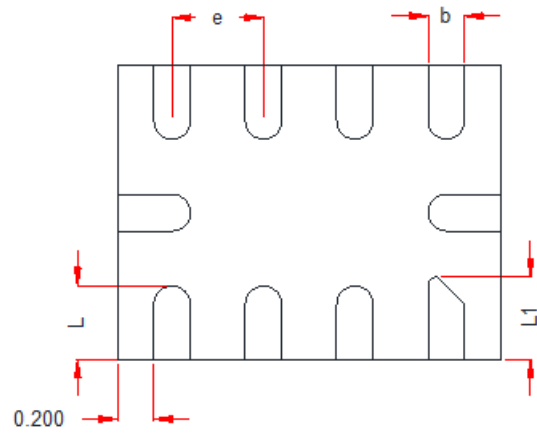

Figure 5: Select input to switch on/off time

PACKAGE OUTLINE DIMENSIONS
QFN2116-10L

TOP VIEW



BOTTOM VIEW

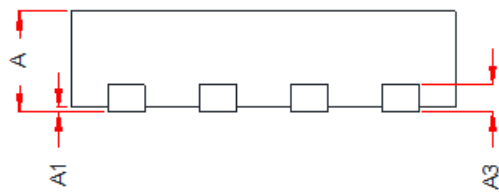

SIDE VIEW

Symbol	Dimensions in Millimeters		
	Min.	Typ.	Max.
A	0.50	0.55	0.60
A1	0.00	-	0.05
A3	0.15 REF.		
D	2.05	2.10	2.15
E	1.55	1.60	1.65
b	0.15	0.20	0.25
L	0.35	0.40	0.45
L1	0.40	0.45	0.50
e	0.50 BSC		

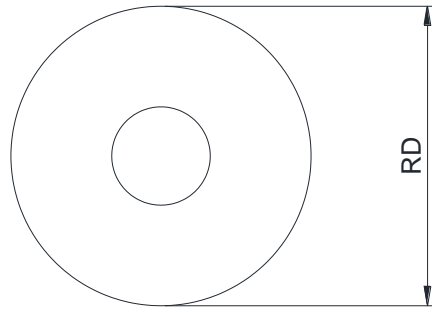
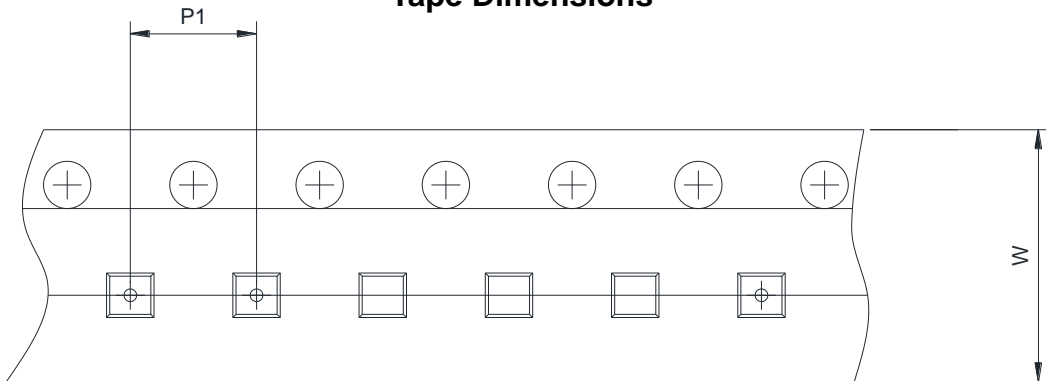
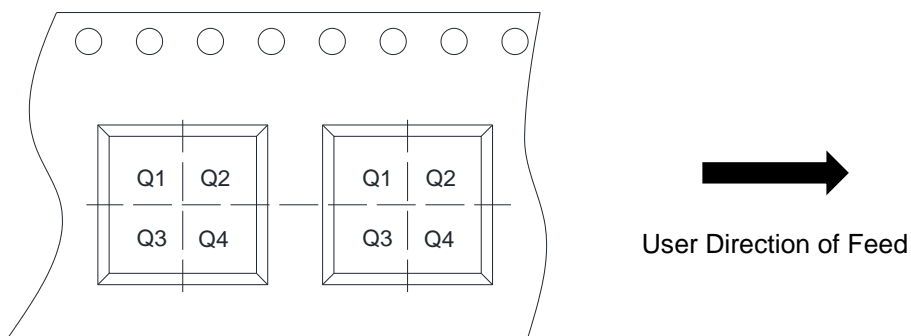
TAPE AND REEL INFORMATION
Reel Dimensions

Tape Dimensions

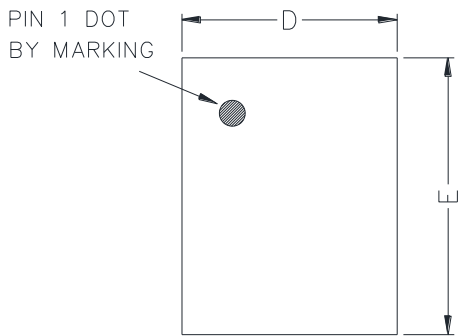
Quadrant Assignments For PIN1 Orientation In Tape

RD	Reel Dimension	<input checked="" type="checkbox"/> 7inch <input type="checkbox"/> 13inch
W	Overall width of the carrier tape	<input checked="" type="checkbox"/> 8mm <input type="checkbox"/> 12mm
P1	Pitch between successive cavity centers	<input type="checkbox"/> 2mm <input checked="" type="checkbox"/> 4mm <input type="checkbox"/> 8mm
Pin1	Pin1 Quadrant	<input checked="" type="checkbox"/> Q1 <input type="checkbox"/> Q2 <input type="checkbox"/> Q3 <input type="checkbox"/> Q4

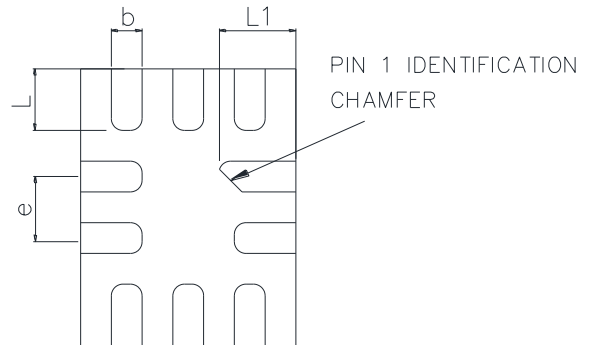
PACKAGE OUTLINE DIMENSIONS
QFN1418-10L

TOP VIEW



BOTTOM VIEW

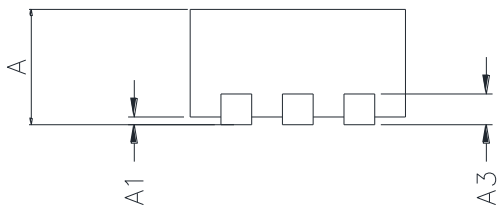

SIDE VIEW

Symbol	Dimensions in Millimeters		
	Min.	Typ.	Max.
A	0.50	0.55	0.60
A1	0.00	-	0.05
A3	0.15 Ref.		
D	1.35	1.40	1.45
E	1.75	1.80	1.85
b	0.15	0.20	0.25
L	0.30	0.40	0.50
L1	0.40	0.50	0.60
e	0.40 BSC		

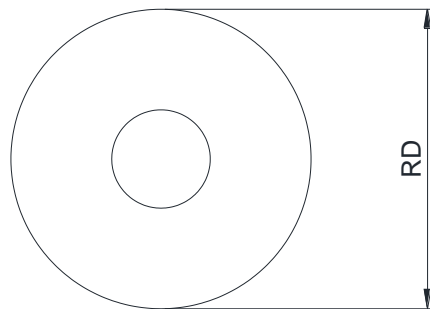
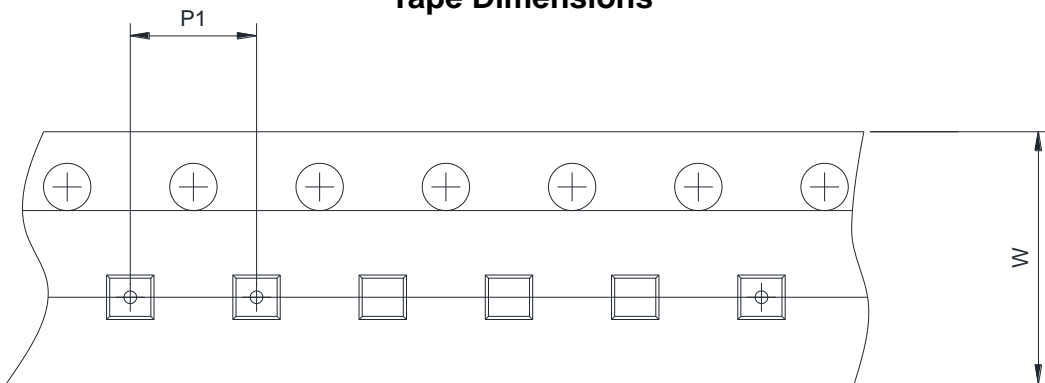
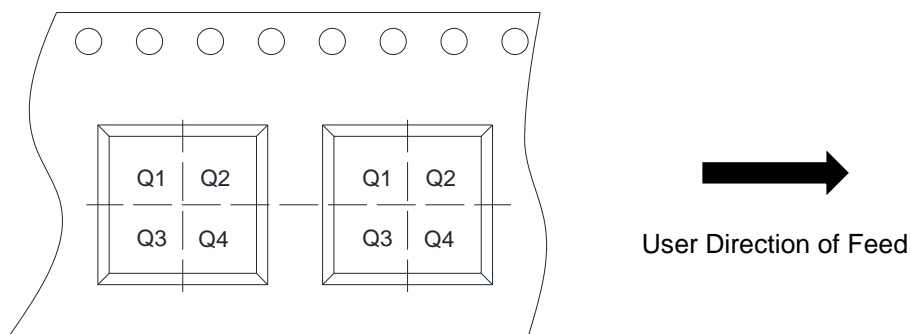
TAPE AND REEL INFORMATION
Reel Dimensions

Tape Dimensions

Quadrant Assignments For PIN1 Orientation In Tape

RD	Reel Dimension	<input checked="" type="checkbox"/> 7inch <input type="checkbox"/> 13inch
W	Overall width of the carrier tape	<input checked="" type="checkbox"/> 8mm <input type="checkbox"/> 12mm
P1	Pitch between successive cavity centers	<input type="checkbox"/> 2mm <input checked="" type="checkbox"/> 4mm <input type="checkbox"/> 8mm
Pin1	Pin1 Quadrant	<input checked="" type="checkbox"/> Q1 <input type="checkbox"/> Q2 <input type="checkbox"/> Q3 <input type="checkbox"/> Q4