

High Voltage Fast-Switching NPN Power Transistor

Features

- Very High Switching Speed
- High Voltage Capability
- Wide Reverse Bias SOA
- Built-in free wheeling diode

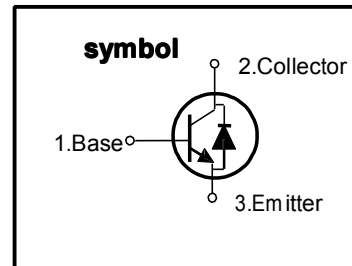

General Description

This Device is designed for high Voltage ,High speed switching Characteristics required such as lighting system,switching mode power supply.

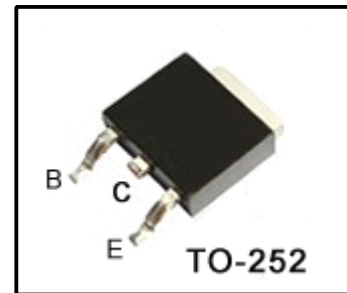

Absolute Maximum Ratings

Symbol	Parameter	Test conditions	Value	Units
V_{CBO}	Collector-Base Voltage	$V_{BE}=0$	600	V
V_{CEO}	Collector-Emitter Voltage	$I_B=0$	400	V
V_{EBO}	Emitter-Base Voltage	$I_C=0$	9.0	V
I_C	Collector Current		2	A
I_{CP}	Collector pulse Current		3.0	A
I_B	Base Current		0.75	A
I_{BM}	Base peak Current	$t_p=5ms$	1.5	A
P_C	Total Dissipation at $T_c^*=25\text{ }^\circ\text{C}$		10	W
T_J	Operation Junction Temperature		150	$^\circ\text{C}$
T_{STG}	Storage Temperature		-55~150	$^\circ\text{C}$

T_c :Case temperature (good cooling)

T_a :Ambient temperature (without heat sink)

Thermal characteristics

Symbol	Parameter	Value	Units
$R_{\theta JC}$	Thermal Resistance Junction to Case	12.5	$^\circ\text{C}/\text{W}$
$R_{\theta JA}$	Thermal Resistance Junction to Ambient	8.9	$^\circ\text{C}/\text{W}$

Electrical Characteristics (T_c=25°C unless otherwise noted)

Symbol	Parameter	Test Conditions	Value			Units
			Min	Typ	Max	
I _{EBO}	Emitter Cut-off Current	V _{BE} =9V	-	-	20	μA
V _{CEO(SUS)}	Collector-Emitter Sustaining Voltage	I _B =0, I _C =10mA	400	-	-	V
V _{CE(sat)}	Collector -Emitter Saturation Voltage	I _C =1.0A, I _B =0.2A I _C =2.0A, I _B =0.5A I _C =4.0A, I _B =1.0A	-	-	0.5 0.6 1.0	V
V _{BE(sat)}	Base -Emitter Saturation Voltage	I _C =1.0A, I _B =0.2A I _C =2.0A, I _B =0.5A	-	-	1.2 1.6	V
h _{FE}	DC Current Gain	I _C =500A, V _{CE} =5V I _C =1mA, V _{CE} =5V	10 9	-	40 -	
t _s t _f	Storage Time Fall Time	I _C =0.5A, V _{CC} =5V (UI9600A)	-	-	4 0.8	μs
f _T	Current Gain Bandwidth Product	I _C =0.5A, V _{CE} =10V	4	-	-	MHz
V _F	Diode Forward Voltage	I _F =2A	-	-	2	V
C _{OB}	Output Capacitance	I _C =0.5A, V _{CB} =10V	-	21		pF

Note:

Pulse Test :Pulse width 300, Duty cycle 2%

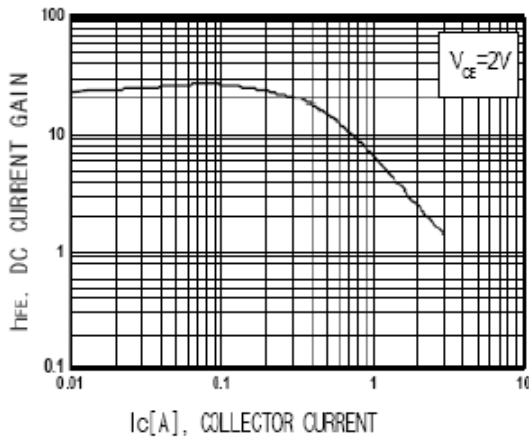

Fig.1 DC Current Gain

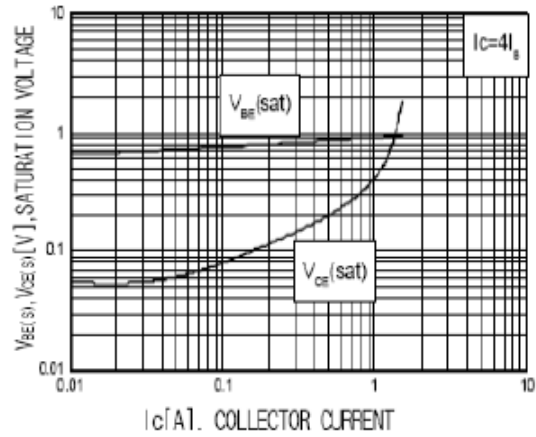

Fig.2 Saturation Voltage

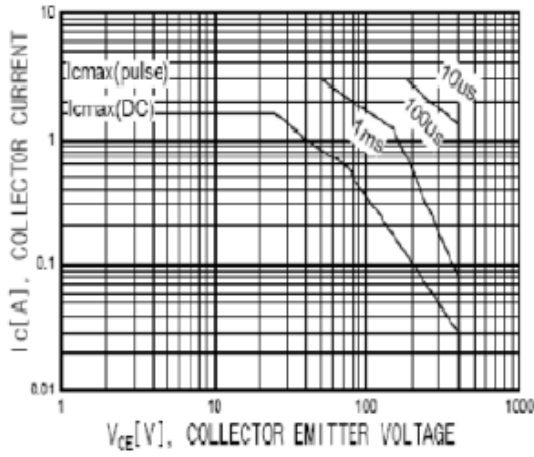

Fig.3 Safe Operation

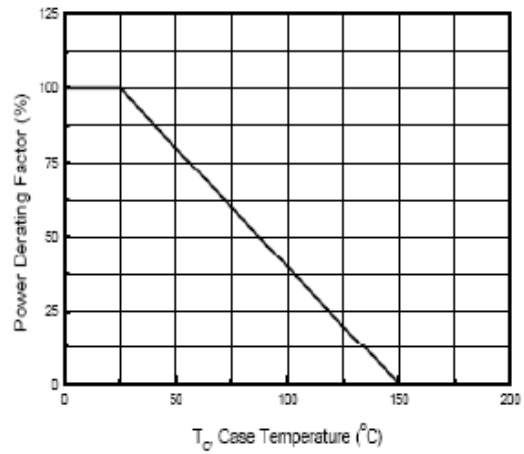
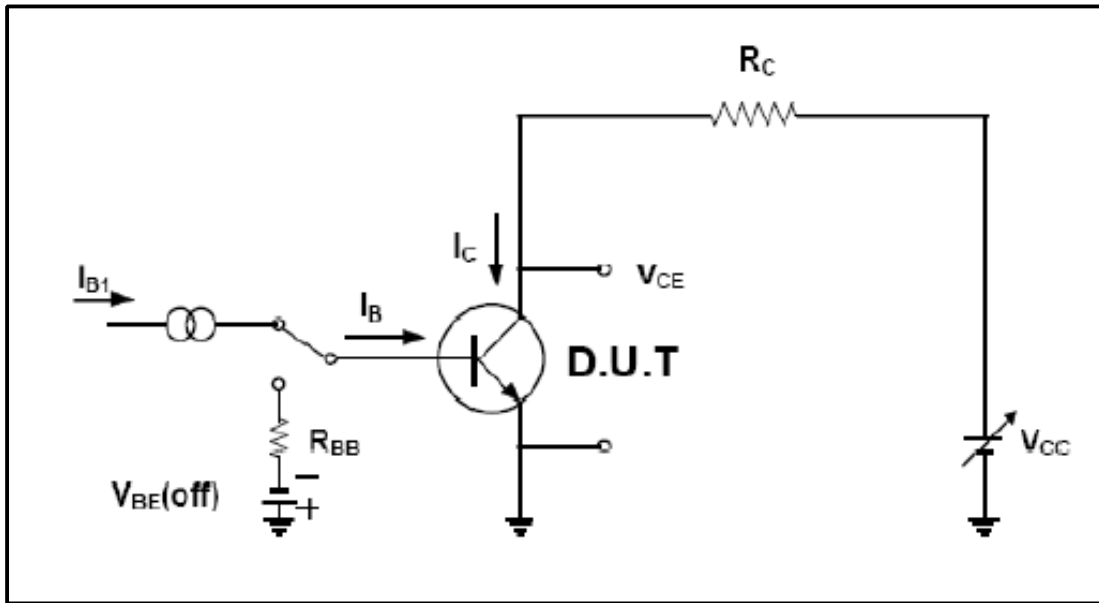
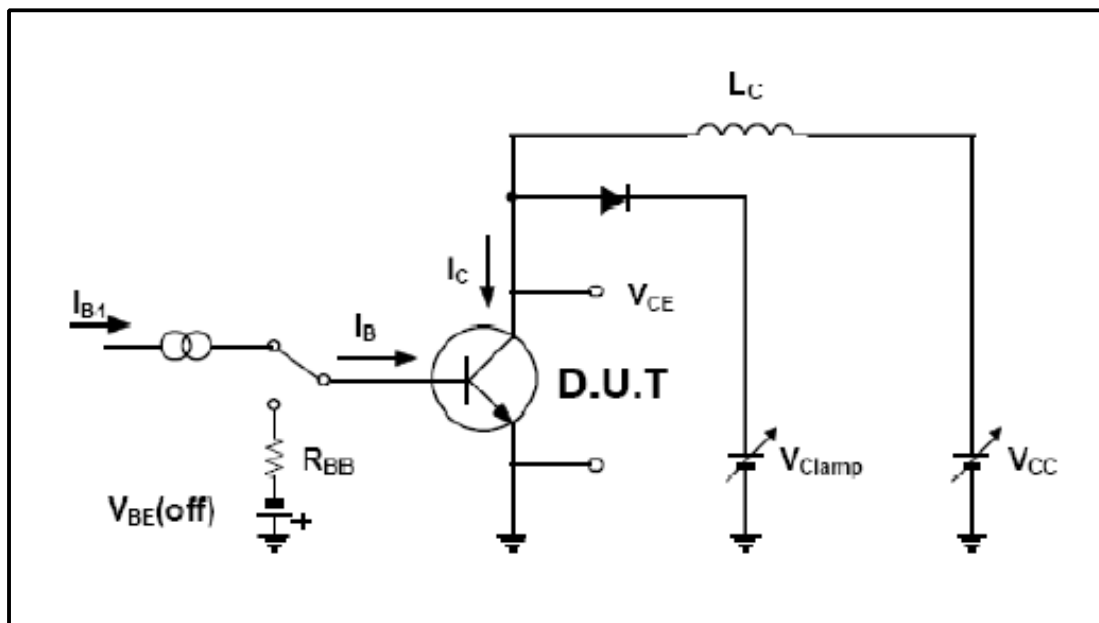

Fig.4 Power Derating



Resistive Load Switching Test Circuit



Inductive Load Switching & RBSOA Test Circuit

TO-252 Package Dimension

