

High Voltage Fast-Switching NPN Power Transistor

Features

- Very High Switching Speed
- High Voltage Capability
- Wide Reverse Bias SOA
- Built-in free wheeling diode

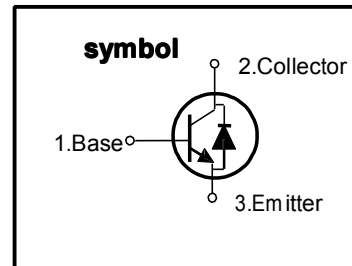

General Description

This Device is designed for high Voltage ,High speed switching Characteristics required such as lighting system,switching mode power supply.

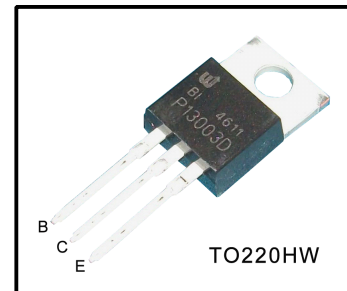

Absolute Maximum Ratings

Symbol	Parameter	Test conditions	Value	Units
V _{CES}	Collector-Emitter Voltage	V _{BE} =0	700	V
V _{CEO}	Collector-Emitter Voltage	I _B =0	400	V
V _{EBO}	Emitter-Base Voltage	I _C =0	9.0	V
I _C	Collector Current		1.5	A
I _{CP}	Collector pulse Current		3.0	A
I _B	Base Current		0.75	A
I _{BM}	Base peak Current	t _p =5ms	1.5	A
P _C	Total Dissipation at T _c *=25 °C		40	W
	Total Dissipation at T _a *=25 °C		1.2	
T _J	Operation Junction Temperature		-40~150	°C
T _{STG}	Storage Temperature		-40~150	°C

T_c :Case temperature (good cooling)

T_a :Ambient temperature (without heat sink)

Thermal characteristics

Symbol	Parameter	Value	Units
R _{θJC}	Thermal Resistance Junction to Case	3.12	°C/W
R _{θJA}	Thermal Resistance Junction to Ambient	8.9	°C/W

Electrical Characteristics($T_c=25^{\circ}\text{C}$ unless otherwise noted)

Symbol	Parameter	Test Conditions	Value			Units
			Min	Typ	Max	
I_{EBO}	Emitter Cut-off Current	$V_{BE}=9V$	–	–	20	μA
$V_{CEO(SUS)}$	Collector–Emitter Sustaining Voltage	$I_B=0, I_C=10\text{mA}$	400	–	–	V
$V_{CE(sat)}$	Collector –Emitter Saturation Voltage	$I_C=1.0A, I_B=0.2A$ $I_C=2.0A, I_B=0.5A$ $I_C=4.0A, I_B=1.0A$	–	–	0.5 0.6 1.0	V
$V_{BE(sat)}$	Base –Emitter Saturation Voltage	$I_C=1.0A, I_B=0.2A$ $I_C=2.0A, I_B=0.5A$	–	–	1.2 1.6	V
h_{FE}	DC Current Gain	$I_C=500A, V_{CE}=5V$ $I_C=1\text{mA}, V_{CE}=5V$	10 9	–	40 –	
t_s t_f	Storage Time Fall Time	$I_C=0.5A, V_{CC}=5V$ (UI9600A)	–	–	4 0.8	μs
f_T	Current Gain Bandwidth Product	$I_C=0.5A, V_{CE}=10V$	4	–	–	MHz
V_F	Diode Forward Voltage	$I_F=2A$	–	–	2	V
C_{OB}	Output Capacitance	$I_C=0.5A, V_{CB}=10V$	–	21		pF

Note:

Pulse Test :Pulse width 300, Duty cycle 2%

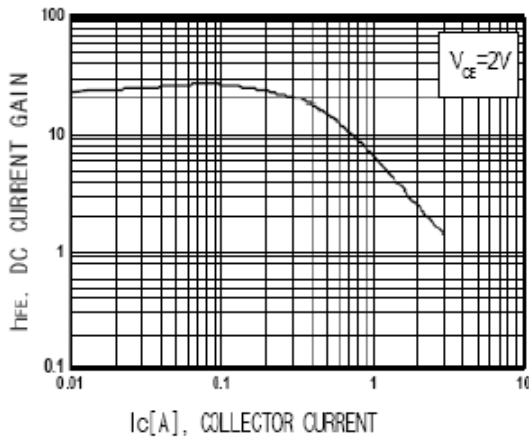

Fig.1 DC Current Gain

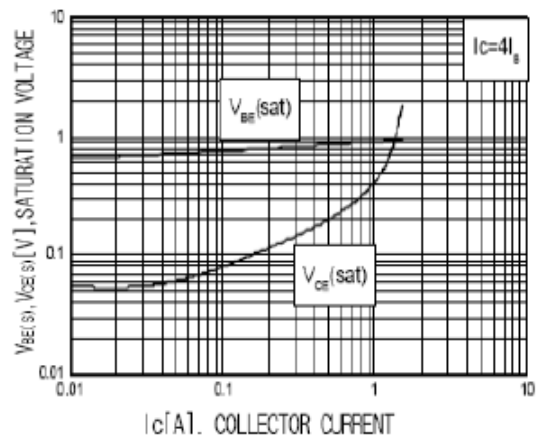

Fig.2 Saturation Voltage

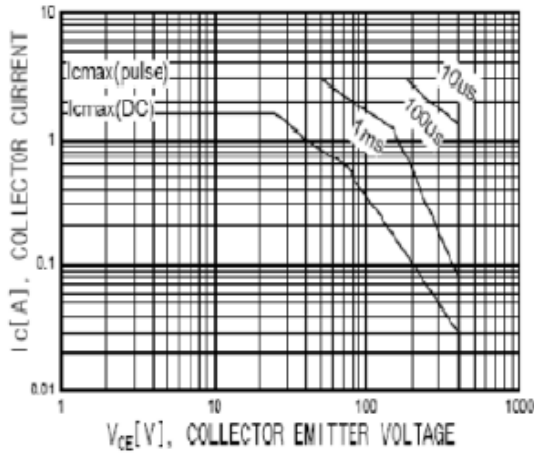

Fig.3 Safe Operation

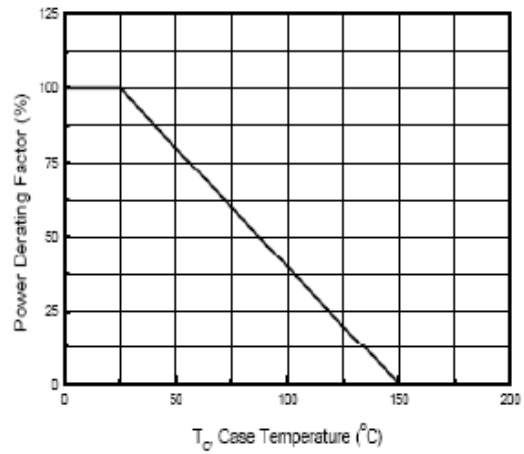
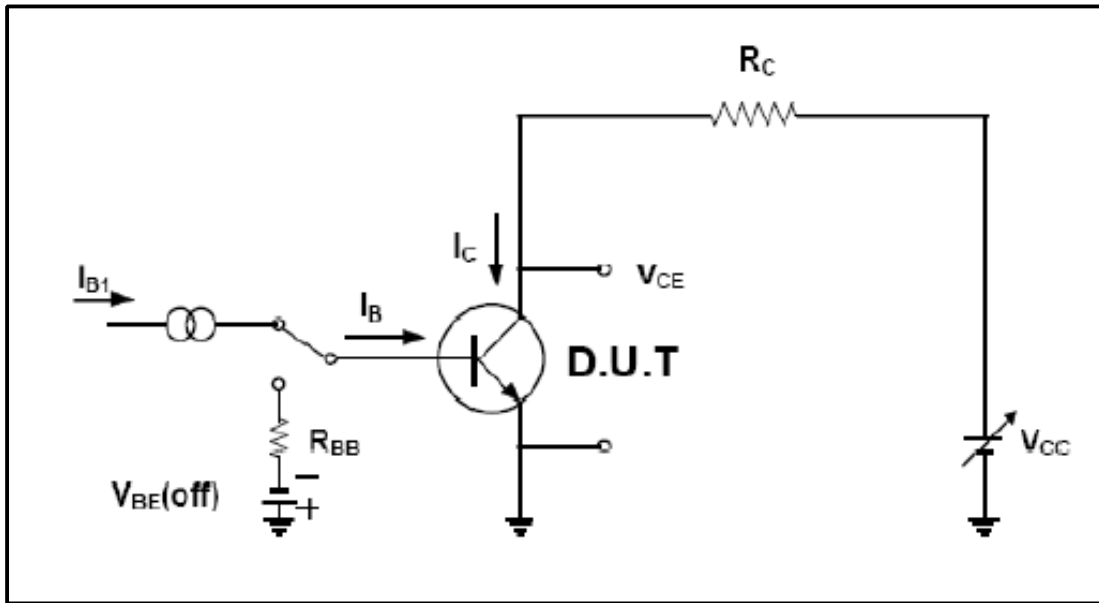
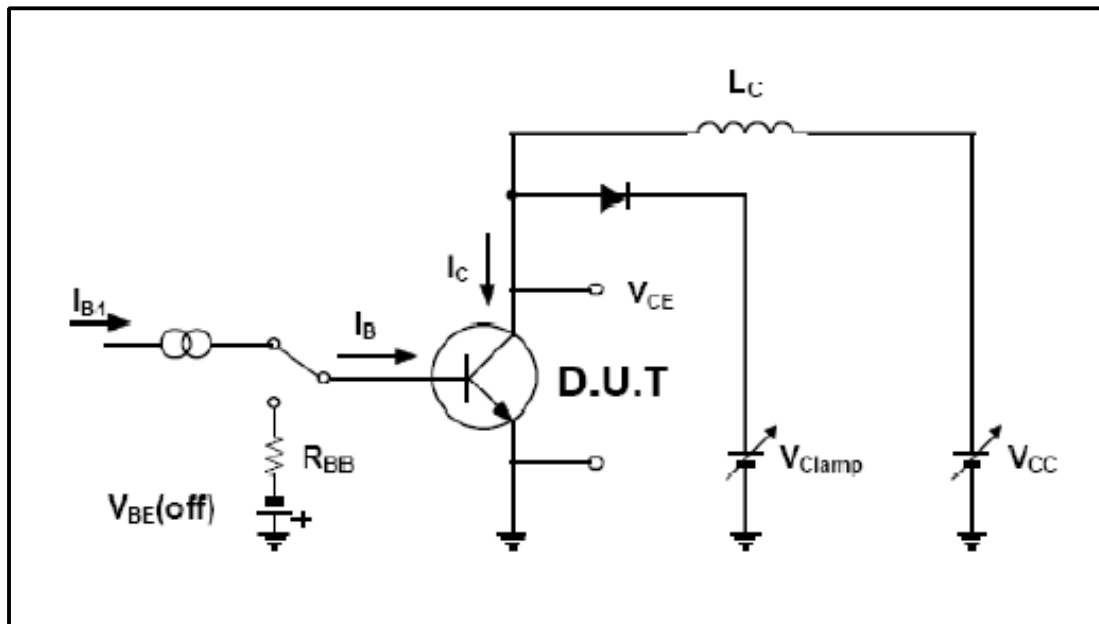

Fig.4 Power Derating



Resistive Load Switching Test Circuit



Inductive Load Switching & RBSOA Test Circuit

TO-220HW Package Dimension

Unit:mm

