

## Hall Effect Base Linear Current Sensor

### Features:

- Low noise analog signal path
- 115  $\mu\Omega$  internal conductor resistance
- Output voltage proportional to AC and DC current
- Min. sensing current 0~60A at 5V voltage supply
- High sensitivity 32mV/A
- Wide operating voltage range 3.0~12V
- Low operating current 3mA
- Nearly zero magnetic hysteresis
- Ratiometric output from supply voltage
- 23KHz Bandwidth



### Functional Description :

The Winson WCS3750 current sensor provides economical and precise solution for both DC and AC current sensing in industrial, commercial and communications systems. The unique package allows for easy implementation by the customer. Typical applications include motor control, load detection and management, over-current fault detection and any intelligent power management system etc...

The WCS3750 consists of a precise, low-temperature drift linear hall sensor IC with temperature compensation circuit and a current path with 115  $\mu\Omega$  typical internal conductor resistance. This extremely low resistance can effectively reduce power loss, operating temperature and increase the reliability greatly. Applied current flowing through this conduction path generates a magnetic field which is sensed by the integrated Hall IC and converted into a proportional voltage.

The terminals of the conductive path are electrically isolated from the sensor leads. This allow the WCS3750 current sensor to be used in applications requiring electrical isolation without the use of opto-isolators or other costly isolation techniques and make system more competitive in cost.

Winson reserves the right to make changes to improve reliability or manufacturability.

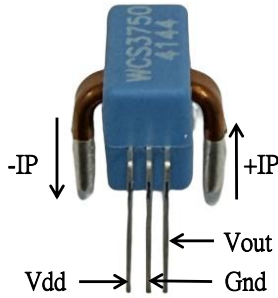

### Absolute Maximum Range

Supply Voltage, Vdd	-----	14V
Pass Current, IP	-----	120A
Output Current Sink	-----	0.4mA
Output Current Source	-----	2mA
Basic Isolation Voltage	-----	1000V
Operating Temperature Range, Ta	-----	-20°C to +125°C
Storage Temperature Range, Ts	-----	-65°C to +150°C
Power Dissipation, Pd	-----	1W

### Vout vs. Primary Current

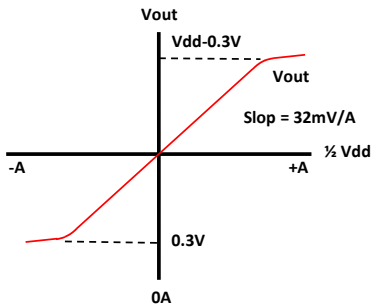

### Order Information

( Vdd = 5V )

Part No.	Sensitivity	Current range
WCS3750	32 mV/A	DC: ±0 ~ 60A
		AC: rms 40A

### Function Block:

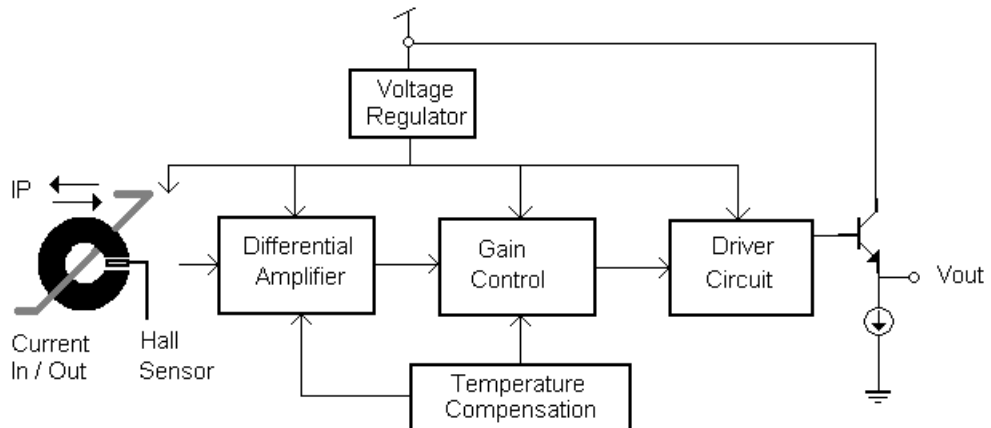

Winson reserves the right to make changes to improve reliability or manufacturability.



# WCS3750

## Electrical Characteristics: (T=+25°C, Vdd=5.0V )

Characteristic	Symbol	Test Conditions	Min	Typ	Max	Units
Supply Voltage	V <sub>dd</sub>	—	3.0	—	12	V
Supply Current	I <sub>supply</sub>	I <sub>P</sub> =0 A	—	3.5	6.0	mA
Zero Current V <sub>out</sub>	V <sub>0G</sub>	I <sub>P</sub> =0 A(DC Mode)	2.4	2.5	2.6	V
Primary Conductor Resistance	R <sub>primary</sub>	I <sub>P</sub> =10 A	—	115	—	μΩ
Sensitivity	Sens	I <sub>P</sub> =±10 A	27	32	37	mV/A
Bandwidth	BW	—	—	23	—	kHz
Measurable Current Range	MR	V <sub>dd</sub> =5V (DC Mode)	—	±40	—	A
		V <sub>dd</sub> =5V (AC RMS )	—	30	—	
Temperature Drift	ΔV <sub>out</sub>	I <sub>p</sub> =0 A	—	±0.5	—	mV/°C
Output Noise	V <sub>Np-p</sub>	I <sub>p</sub> =0 A	—	7.5	—	mV
	V <sub>Np-p(0.01uF)</sub>	I <sub>p</sub> =0 A, C = 0.01uF	—	1	—	

1. All output-voltage measurements are made with a voltmeter having an input impedance of at least 100kΩ

2. Do not apply any 'resistor load' on output pin, it will degrade IC's performance

## Characteristic Diagrams:

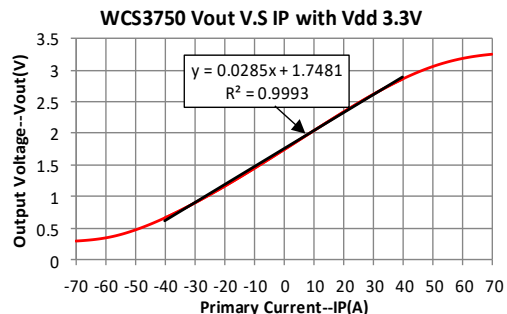
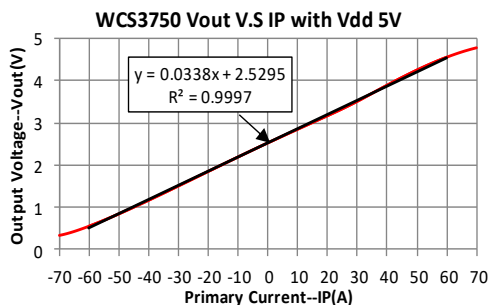
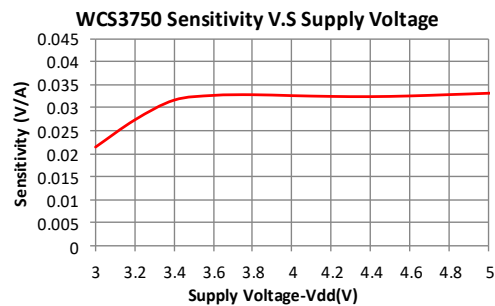
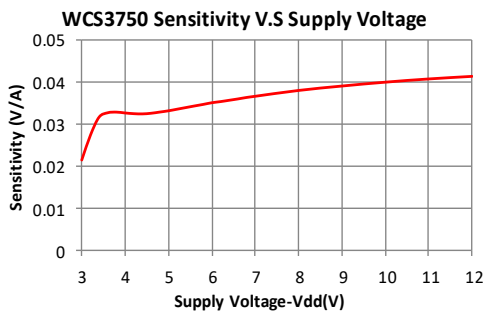

Winson reserves the right to make changes to improve reliability or manufacturability.

WCS3750 Sensitivity Standardization of 30°C VS. IP with Vdd 5.0V

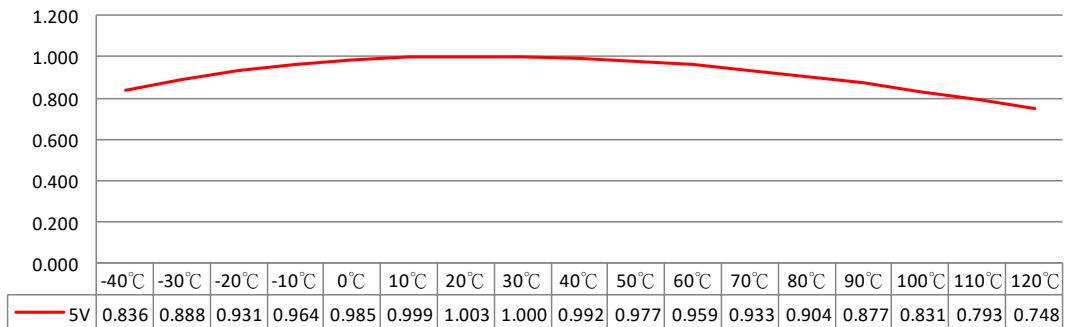

WCS3750 Sensitivity Standardization of 30°C VS. IP with Vdd 3.3V

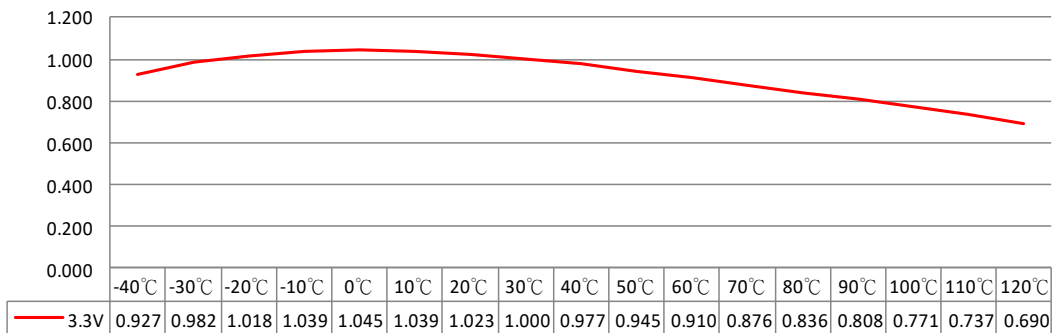

### Application Circuit:

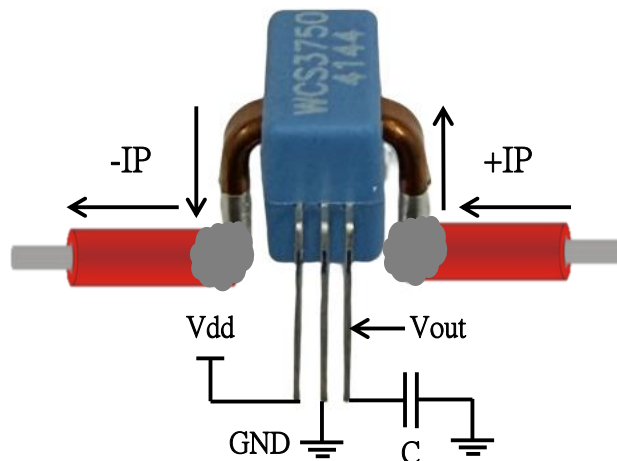

Capacitor **C**(0.01uF~0.1uF) is recommend to be connected between Vout and GND to reduce output noise.

Winson reserves the right to make changes to improve reliability or manufacturability.

## Package Information:

(Unit: mm)

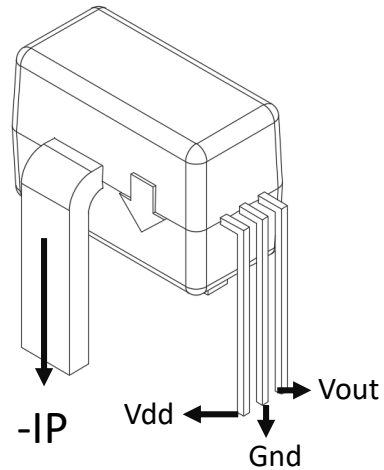
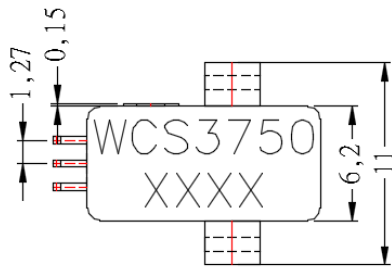
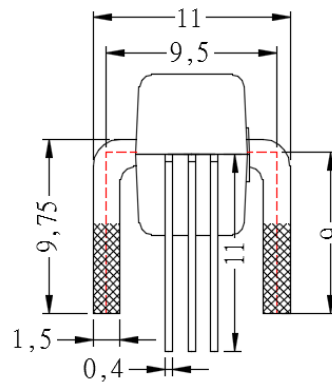
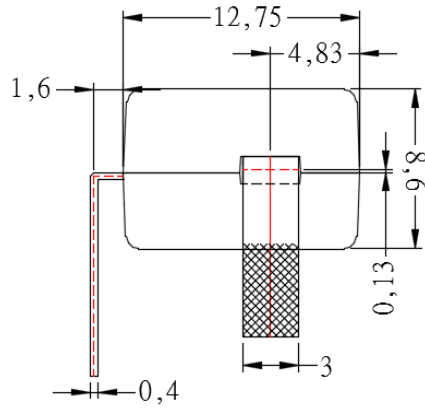

## PCB Layout Reference Top View

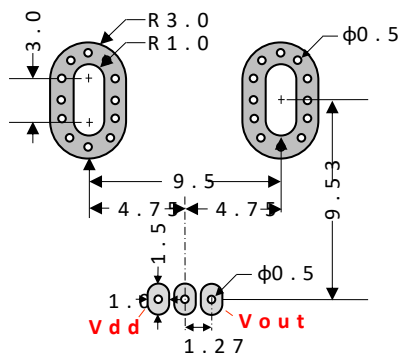

**WCS Application Note** : please refer to Winson Website -> Products->

Application Note -> WCS Application Note :

<http://www.winson.com.tw/Product/83>

Winson reserves the right to make changes to improve reliability or manufacturability.