

Hall Effect Base Linear Current Sensor

Features:

- Low noise analog signal path
- 1.5Ω internal conductor resistance
- Output voltage proportional to AC and DC current
- Min. sensing current 0~0.5A at 5V voltage supply
- High Sensitivity 3.5mV/mA
- Wide operating voltage range 3.0~12 V.
- Low operating current 3mA
- Nearly zero magnetic hysteresis.
- Ratiometric output from supply voltage
- 4K Hz bandwidth
- Isolation voltage 1000V

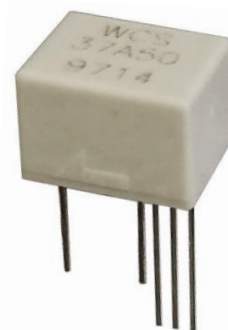

Functional Description :

The Winson WCS37A50 provides economical and precise solution for both DC and AC current sensing in industrial, commercial and communications systems. The unique package allows for easy implementation by the customer. Typical applications include motor control, load detection and management, over-current fault detection and any intelligent power management system etc...

The WCS37A50 consists of a precise, low-temperature drift linear hall sensor IC with temperature compensation circuit and a current path with 1.5Ω typical internal conductor resistance. This extremely low resistance can effectively reduce power loss, operating temperature and increase the reliability greatly. Applied current flowing through this conduction path generates a magnetic field which is sensed by the integrated Hall IC and converted into a proportional voltage.

The terminals of the conductive path are electrically isolated from the sensor leads. This allow the WCS37A50 current sensor to be used in applications requiring electrical isolation without the use of opto-isolators or other costly isolation techniques and make system more competitive in cost.

Winson reserves the right to make changes to improve reliability or manufacturability.

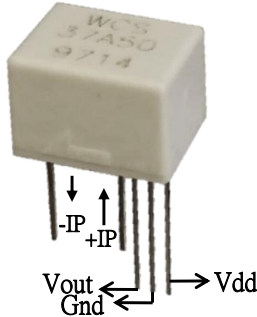

Absolute Maximum Range

Supply Voltage, Vdd -----	14V
Pass Current, IP-----	0.5A
Output Current Sink-----	0.4mA
Output Current Source-----	2mA
Basic Isolation Voltage -----	1000V
Operating Temperature Range, Ta -----	-20°C to +125°C
Storage Temperature Range, Ts -----	-65°C to +150°C
Power Dissipation, Pd -----	1W

Vout vs. Primary Current

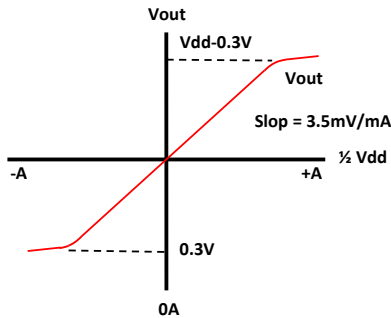

Order Information (Vdd = 5V)

Part No.	Sensitivity	Current range
WCS37A50	3.5mV/mA	DC: $\pm 0 \sim 0.5A$
		AC: rms 0.35A

Function Block:

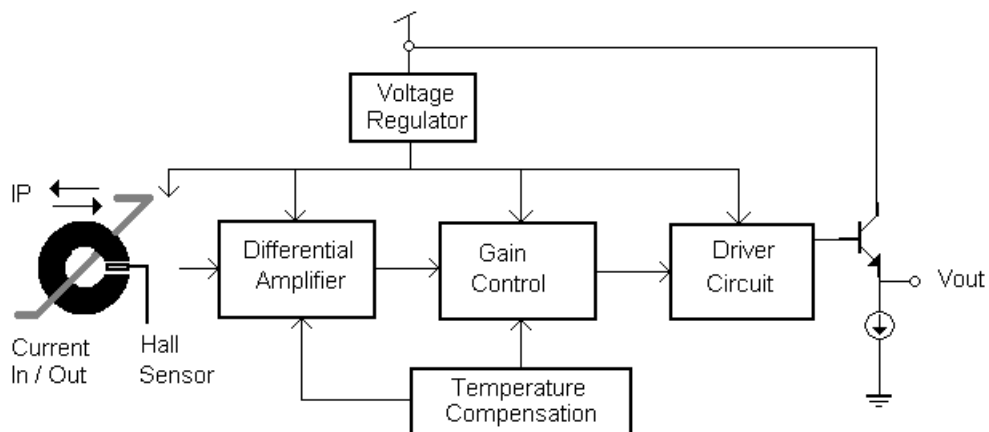

Winson reserves the right to make changes to improve reliability or manufacturability.

Electrical Characteristics:

(T=+25°C, Vdd=5.0V)

Characteristic	Symbol	Test Conditions	Min	Typ	Max	Units
Supply Voltage	Vdd	—	3.0	—	12	V
Supply Current	I _{supply}	IP = 0 A	—	3.5	6.0	mA
Zero Current Vout	V _{0G}	IP = 0 A	2.375	2.5	2.625	V
Primary Conductor Resistance	R _{primary}	IP = 0.12 A	—	1.5	—	Ω
Sensitivity	Δ Vout	IP = 0.2 A	3.0	3.5	4.0	mV/mA
Bandwidth	BW	—	—	10	—	kHz
Measurable Current Range	MCR	Vdd=5V (DC Mode)	—	±0.5	—	A
		Vdd=5V (AC RMS)	—	0.35	—	
Temperature Drift	Δ Vout	IP = 0 A	—	±0.5	—	mV/°C
Output Noise	V _{Np-p}	IP = 0 A	—	7.5	—	mV
	V _{Np-p(0.01uF)}	IP = 0 A, C = 0.01uF	—	1	—	

1. All output-voltage measurements are made with a voltmeter having an input impedance of at least 100kΩ

2. Do not apply any 'resistor load' on output pin, it will degrade IC's performance.

Characteristic Diagrams:

WCS37A50 Sensitivity VS. Supply Voltage

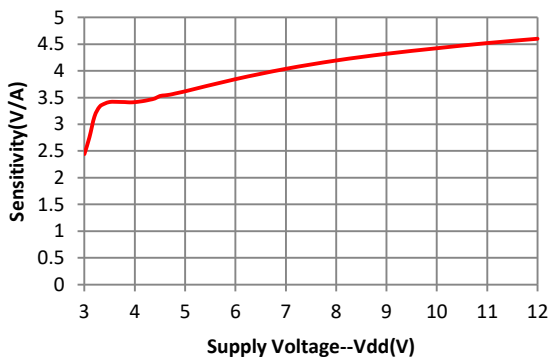

WCS37A50 Sensitivity VS. Supply Voltage

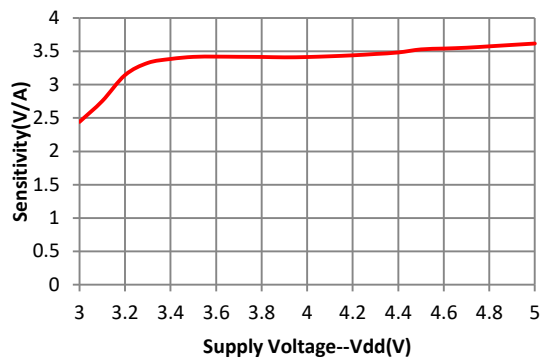

WCS37A50 Vout VS. IP with Vdd 5V

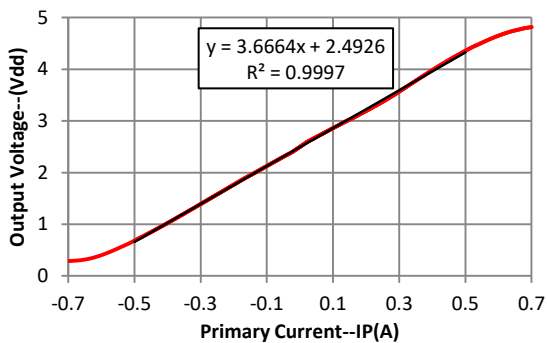

WCS37A50 Vout VS. IP with Vdd 3.3V

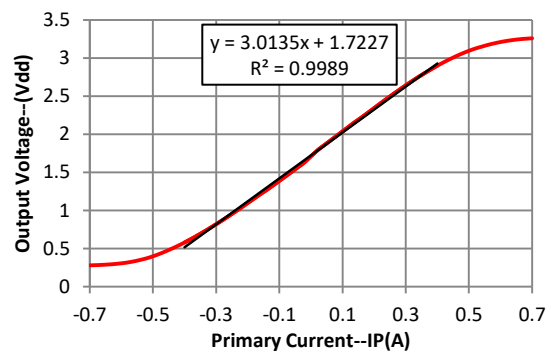

Winson reserves the right to make changes to improve reliability or manufacturability.

WCS37A50 Sensitivity standardization of 30°C (5V) VS. Temperature

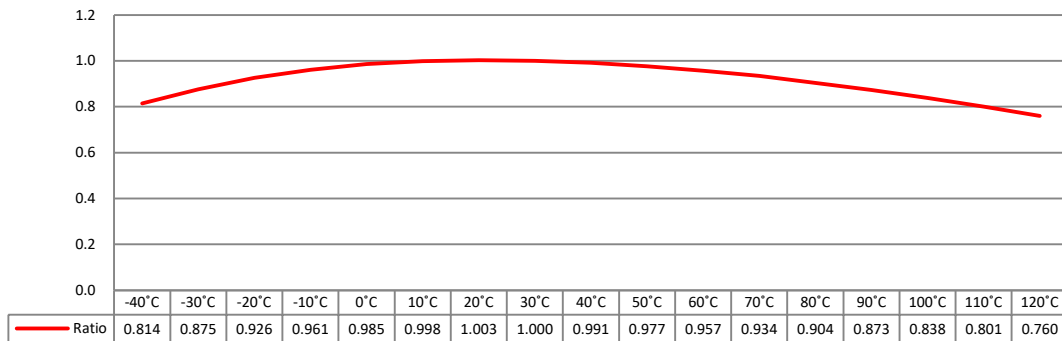

WCS37A50 Sensitivity standardization of 30°C (3.3V) VS. Temperature

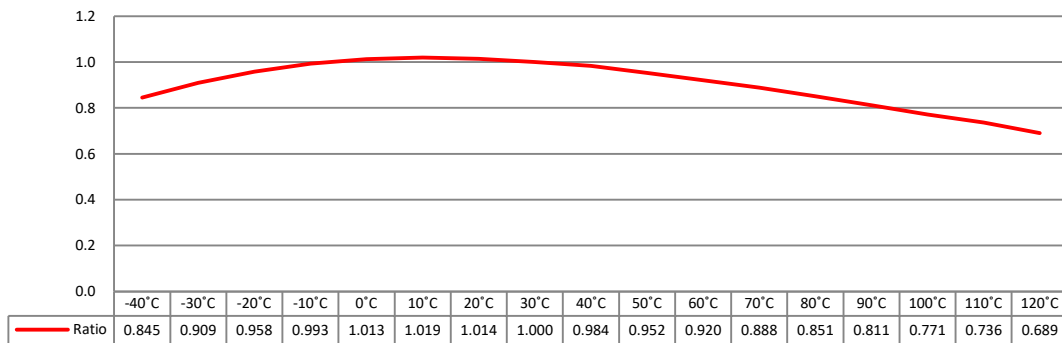

WCS37A50 Unit Gain VS. Frequency

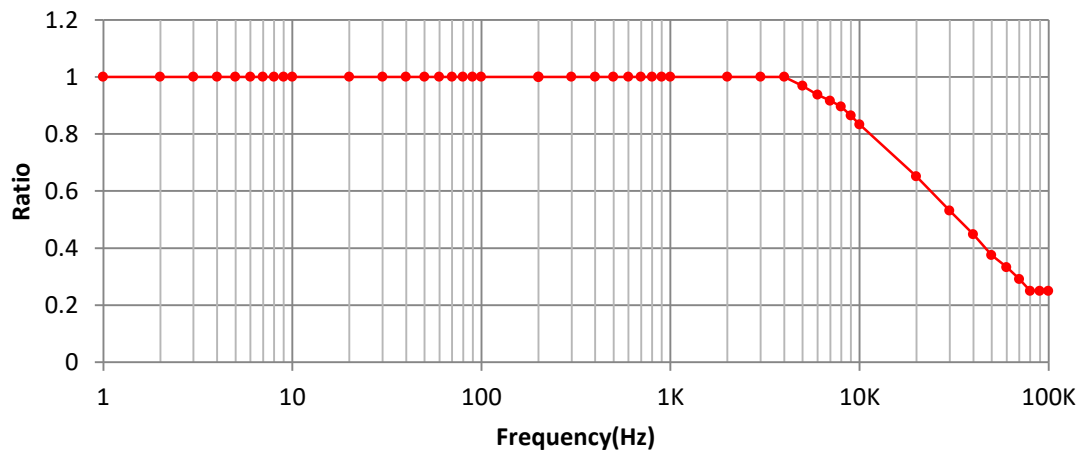

Winson reserves the right to make changes to improve reliability or manufacturability.

Response Time of Pulse Current

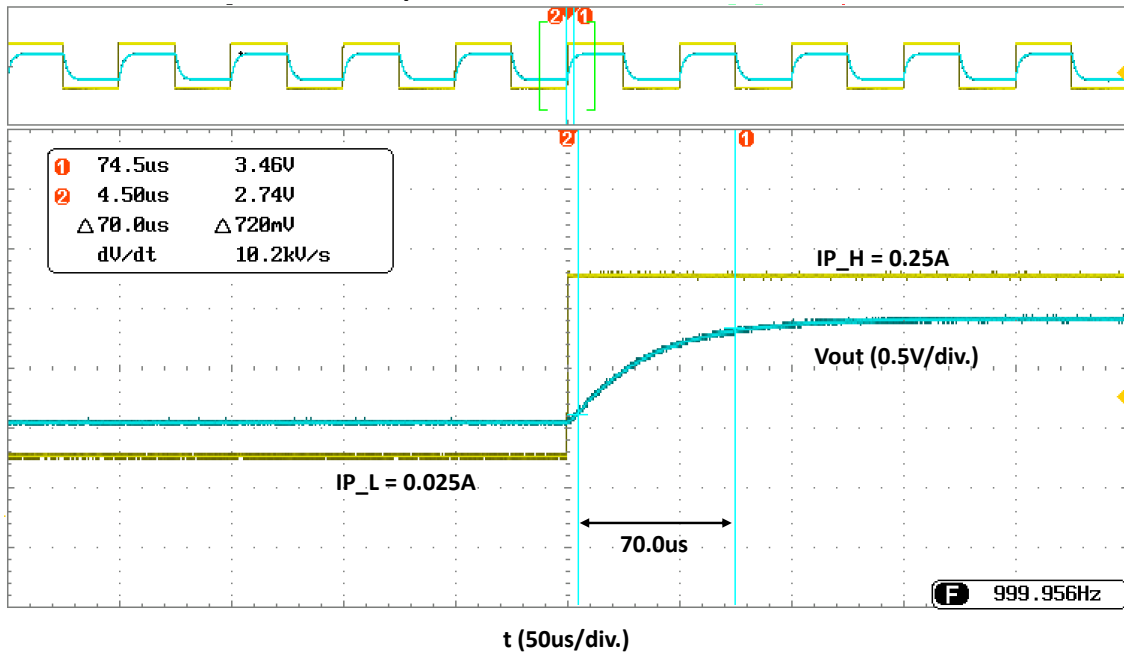

Response Time of Pulse Current

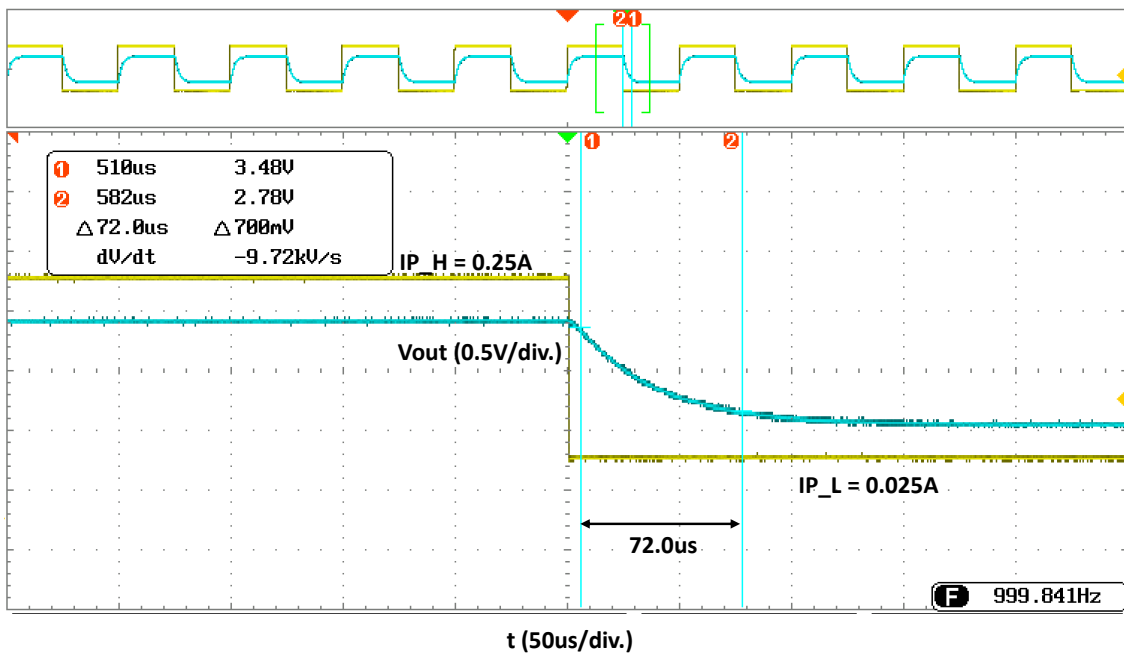

Winson reserves the right to make changes to improve reliability or manufacturability.

Application Circuit:

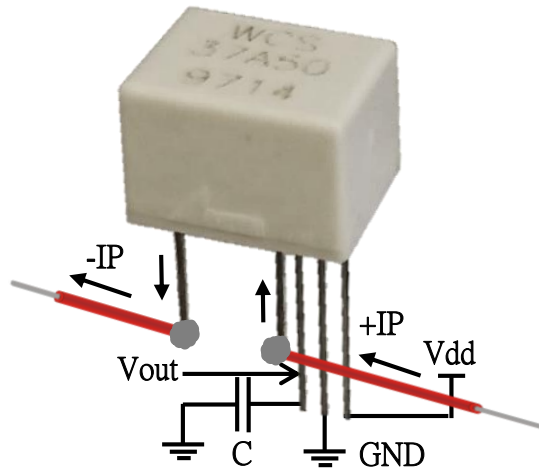

Capacitor **C**(0.01uF~0.1uF) is recommend to be connected between Vout and GND to reduce output noise.

Package Information:

(Unit: mm)

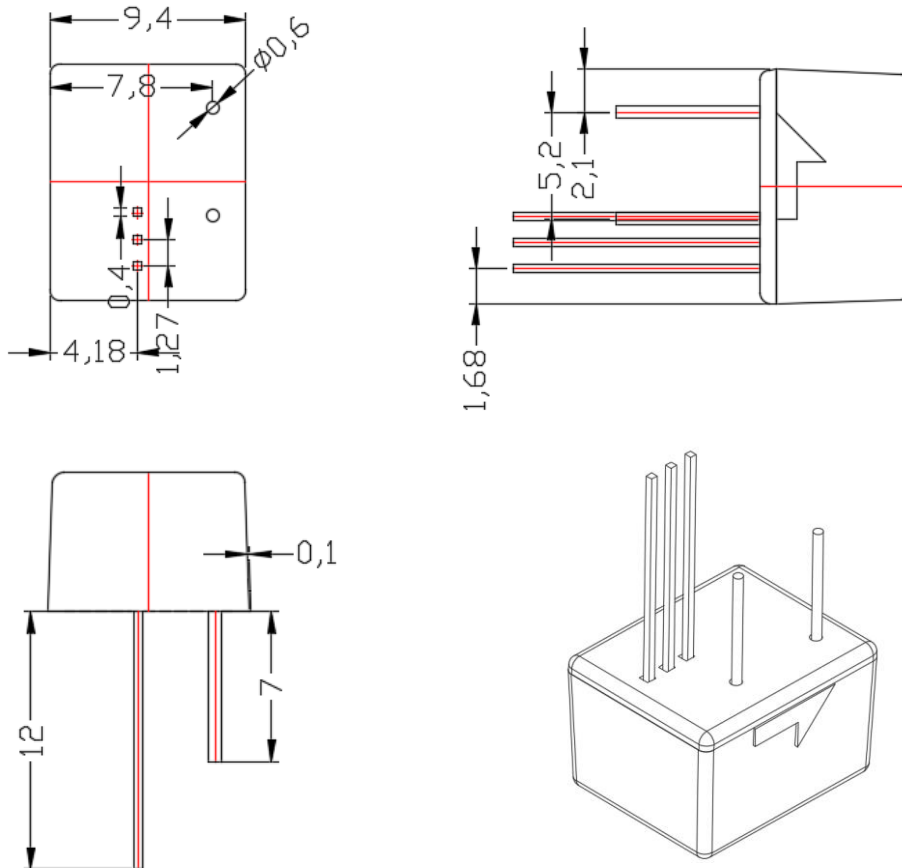

PCB Layout Reference View(Top View)

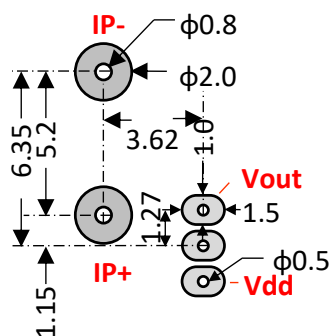

WCS Application Note : please refer to Winson Website -> Products->

Application Note -> WCS Application Note :

<http://www.winson.com.tw/Product/83>

Winson reserves the right to make changes to improve reliability or manufacturability.