

WESTERN DIGITAL

C O R P O R A T I O N

WD2143-01 Four Phase Clock Generator

FEATURES

- TRUE AND INVERTED OUTPUTS
- SINGLE 5 VOLT SUPPLY
- TTL COMPATIBLE
- ON CHIP OSCILLATOR
- XTAL OR TTL CLOCK INPUTS
- 3 MHz OPERATION
- TTL CLOCK OUTPUT
- PROGRAMMABLE PULSE WIDTHS
- PROGRAMMABLE PHASE WIDTHS
- NO EXTERNAL CAPACITOR
- NON-OVERLAPPING OUTPUTS

GENERAL DESCRIPTION

The WD2143-01 Four-Phase Clock Generator is a MOS/LSI device capable of generating four non-overlapping clocks. The output pulse widths are controlled by tying an external resistor to the proper control inputs. All pulse widths may be set to the same width by tying the ϕPW line through an external resistor. Each pulse width can also be individually programmed by tying a resistor through the appropriate $\phi 1PW - \phi 4PW$ control inputs. In addition, the OSC OUT line provides a TTL square wave output at a divide-by-four of the crystal frequency.

Z01-10ms 2

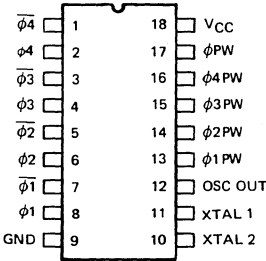
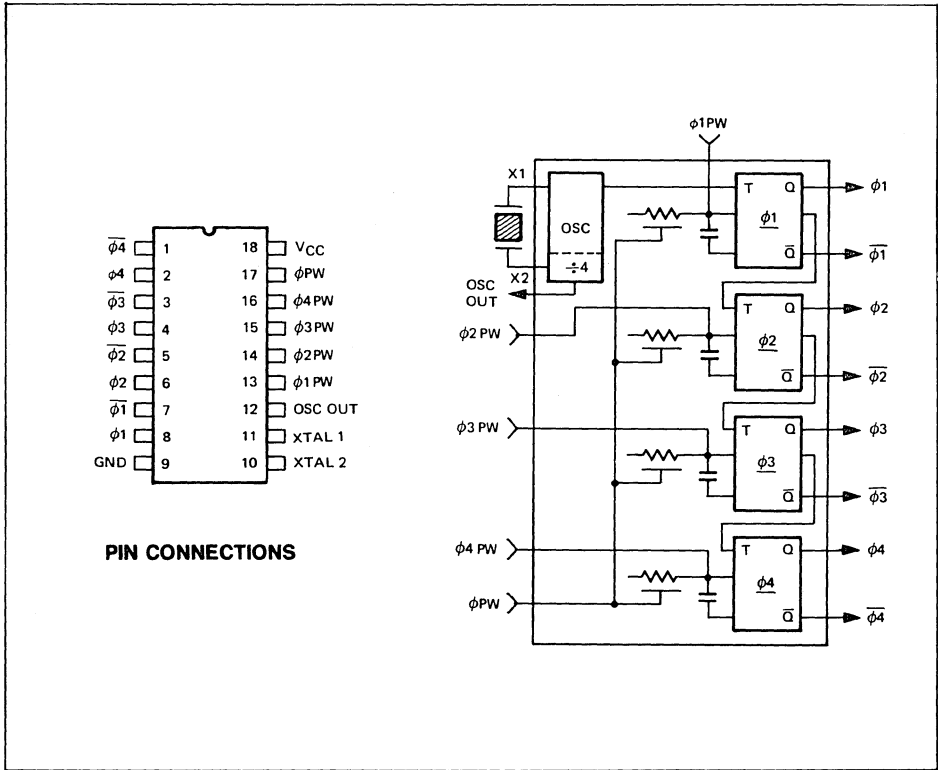

WD2143-01 BLOCK DIAGRAM

PIN NUMBER	SYMBOL	DESCRIPTION
1, 3, 5, 7	$\overline{01}-\overline{04}$	Four phase, non-overlapping outputs. These outputs are inverted (active low).
2, 4, 6, 8	01-04	Four Phase, non-overlapping outputs. These outputs are true (active high).
9	GND	Ground
10, 11	XTAL1 XTAL2	External XTAL connections. An external crystal tied to these pins will cause the oscillator to oscillate at the crystal frequency.
12	OSC OUT	A TTL compatible output that is a divide-by-four of the crystal frequency.
13-16	01PW-04PW	External resistor inputs to control the individual pulse widths of each output. These pins can be left open if 0PW is used.
17	0PW	External resistor input to control all phase outputs to the same pulse widths.
18	V _{CC}	+5V ± 5% power supply input

DEVICE OPERATION

Each of the phase outputs can be controlled individually by tying an external resistor from 01PW-04PW to a +5V supply. When it is desired to have 01 through 04 outputs the same width, the 01PW-04PW inputs should be left open and an external resistor tied from the 0PW (Pin 17) input to +12V.

XTAL1 and XTAL2 can be connected directly to a series-resonant crystal, forcing the internal oscillator to oscillate to the crystal frequency. XTAL2 (pin 11) may also be driven by a TTL square wave with XTAL1 (pin 10) left open. Each of the four phase outputs provide both true and inverted signals, capable of driving 1 TTL load each.

TYPICAL APPLICATIONS

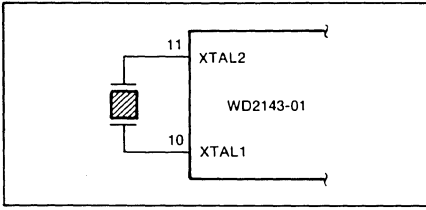

EXTERNAL CRYSTAL OPERATION

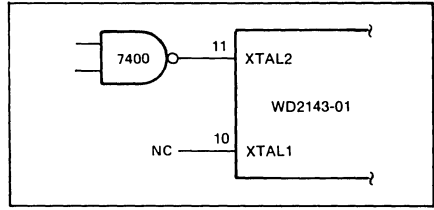

TTL SQUARE WAVE OPERATION

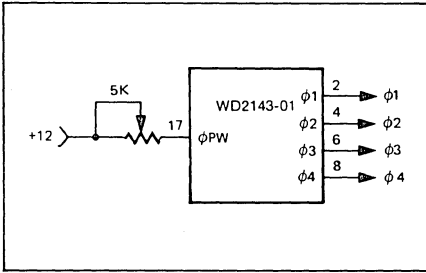

EQUAL PULSE WIDTH OUTPUTS

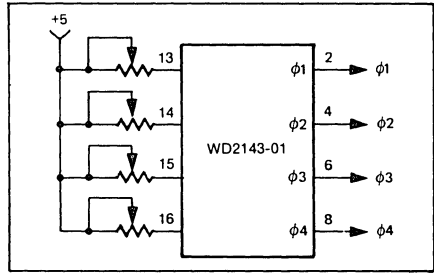

INDIVIDUAL PULSE WIDTH OUTPUTS

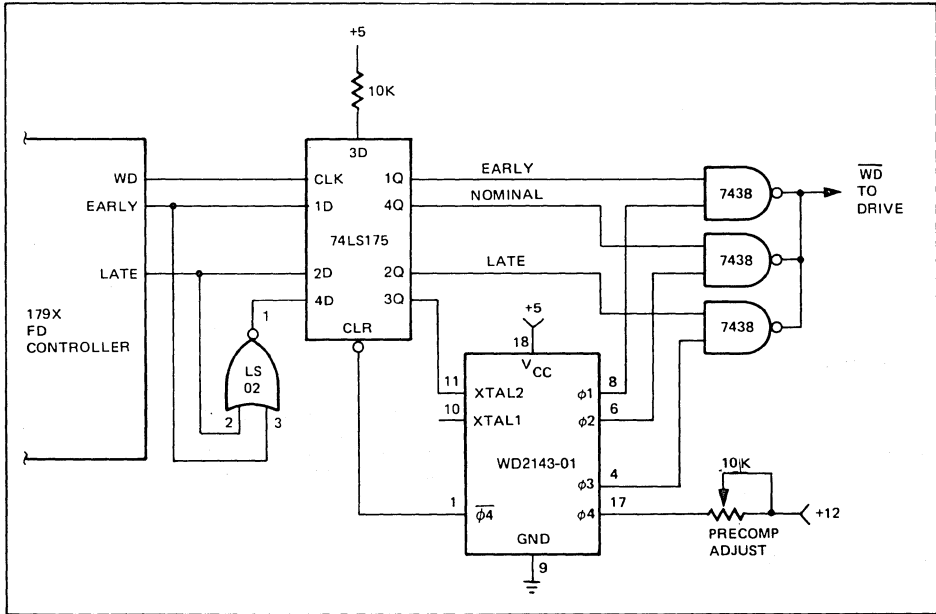

WRITE PRECOMP FOR FLOPPY DISK

2 ZO-10m6

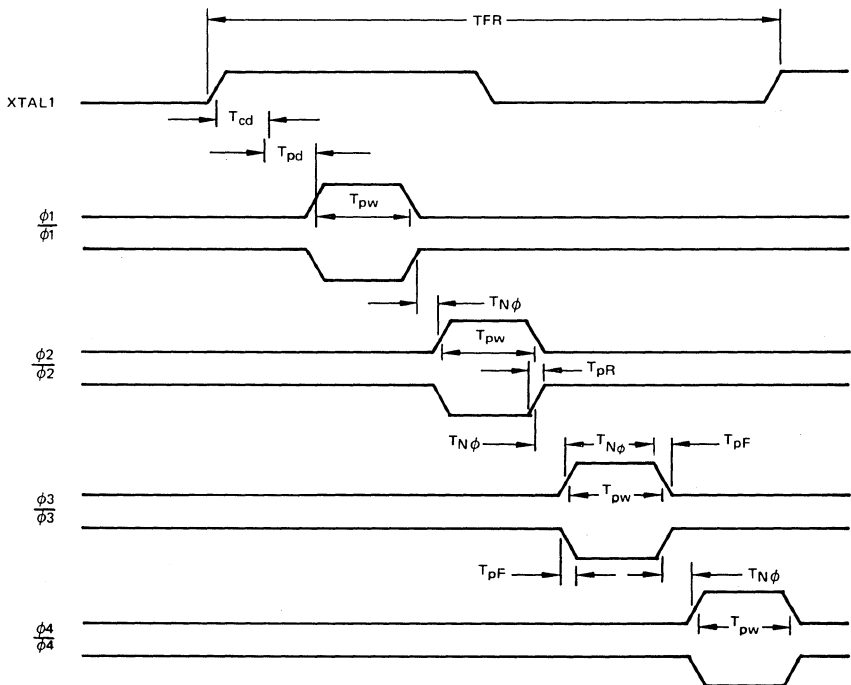

NOTES:
 T_{cd} MEASURED FROM 90% V_{OH} POINTS
 T_{pw} MEASURED FROM 50% V_{OH} POINTS

WD2143-01 TIMING DIAGRAM

SPECIFICATIONS

Absolute Maximum Ratings		Note: Maximum ratings indicate limits beyond which permanent damage may occur. Continuous operation at these limits is not intended and should be limited to the DC electrical characteristics specified.
Operating Temperature	0° to $+70^{\circ}$ C	
Voltage on any pin with respect to Ground	-0.5 to +7V	
Power Dissipation	1 Watt	
Storage Temperature	-55° to $+125^{\circ}$ C	

DC ELECTRICAL CHARACTERISTICS

$V_{CC} = +5V \pm 5\%$ R(\emptyset NPW) or R(\emptyset PW) = 5K, GND = 0V $T_A = 0^\circ$ to 70° C

SYMBOL	PARAMETER	MIN.	MAX.	UNITS	CONDITIONS
V_{ol}	TTL low level output		0.4	V	$I_{ol} = 1.6$ ma.
V_{oh}	TTL high level output	2.4		V	$I_{oh} = 100$ ua.
V_{il}	XTAL in low voltage		0.8	V	
V_{ih}	XTAL in high voltage	2.4		V	
I_{cc}	Supply Current		80	ma	All outputs open

SWITCHING CHARACTERISTICS

$V_{CC} = 5V \pm 5\%$, GND = 0V $T_A = 0^\circ$ to 70° C

SYMBOL	PARAMETER	MIN.	MAX.	UNITS	CONDITIONS
T_{cd}	XTAL in to OSC out (\uparrow)		100	NS	
T_{pd}	OSC out to $\emptyset 1$		100	NS	

SYMBOL	PARAMETER	MIN.	MAX.	UNITS	CONDITIONS
T_{pw}	Pulse Width (any output)	100		NS	$CL = 30$ pf $\emptyset PW = 5K$
$T_{n\phi}$	Non-Overlap Time	20		NS	
T_{pr}	Rise Time (any output)		30	NS	$CL = 30$ pf
T_{pf}	Fall Time (any output)		25	NS	$CL = 30$ pf
TFR	OSC in Frequency External Resistor		3 100	mHz k.Ω	$\emptyset PW$ or $\emptyset NPW$
T_{pw}	Pulse Width Differential		5	%	$\emptyset PW = 5K$

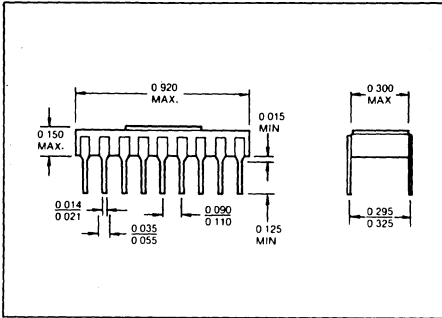

WD2143L-01 CERAMIC PACKAGE

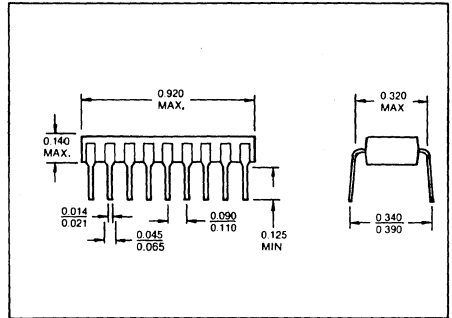

WD2143M-01 PLASTIC PACKAGE

This is a preliminary specification with tentative device parameters and may be subject to change after final product characterization is completed.

Information furnished by Western Digital Corporation is believed to be accurate and reliable. However, no responsibility is assumed by Western Digital Corporation for its use; nor any infringements of patents or other rights of third parties which may result from its use. No license is granted by implication or otherwise under any patent or patent rights of Western Digital Corporation. Western Digital Corporation reserves the right to change said circuitry at any time without notice.

WESTERN DIGITAL
CORPORATION

3128 REDHILL AVENUE, BOX 2180
NEWPORT BEACH, CA 92663 (714) 557-3550, TWX 910-595-1139