



## 128MB- 16Mx64 DDR SDRAM UNBUFFERED W/PLL

### FEATURES

- Double-data-rate architecture
- Speed of 100MHz, 133MHz and 166MHz
- Bi-directional data strobes (DQS)
- Differential clock inputs (CK & CK#)
- Programmable Read Latency 2,2,5 (clock)
- Programmable Burst Length (2,4,8)
- Programmable Burst type (sequential & interleave)
- Edge aligned data output, center aligned data input
- Auto and self refresh
- Serial presence detect
- JEDEC standard 200 pin SO-DIMM package
- Power Supply: 2.5V  $\pm$  0.25V

### DESCRIPTION

The WED3DG6418S is a 16Mx64 Double Data Rate SDRAM memory module based on 128Mb DDR SDRAM component. The module consists of eight 16Mx8 DDR SDRAMs in 66 pin TSOP package mounted on a 200 Pin FR4 substrate.

Synchronous design allows precise cycle control with the use of system clock. Data I/O transactions are possible on both edges and Burst Lengths allow the same device to be useful for a variety of high bandwidth, high performance memory system applications.



**PIN CONFIGURATIONS**

Pin	Symbol	Pin	Symbol	Pin	Symbol	Pin	Symbol
1	V <sub>REF</sub>	51	V <sub>SS</sub>	101	A9	151	DQ42
2	V <sub>REF</sub>	52	V <sub>SS</sub>	102	A8	152	DQ46
3	V <sub>SS</sub>	53	DQ19	103	V <sub>SS</sub>	153	DQ43
4	V <sub>SS</sub>	54	DQ23	104	V <sub>SS</sub>	154	DQ47
5	DQ0	55	DQ24	105	A7	155	V <sub>CC</sub>
6	DQ4	56	DQ28	106	A6	156	V <sub>CC</sub>
7	DQ1	57	V <sub>CC</sub>	107	A5	157	V <sub>CC</sub>
8	DQ5	58	V <sub>CC</sub>	108	A4	158	NC
9	V <sub>CC</sub>	59	DQ25	109	A3	159	V <sub>SS</sub>
10	V <sub>CC</sub>	60	DQ29	110	A2	160	NC
11	DQS0	61	DQS3	111	A1	161	V <sub>SS</sub>
12	DM0	62	DM3	112	A0	162	V <sub>SS</sub>
13	DQ2	63	V <sub>SS</sub>	113	V <sub>CC</sub>	163	DQ48
14	DQ6	64	V <sub>SS</sub>	114	V <sub>CC</sub>	164	DQ52
15	V <sub>SS</sub>	65	DQ26	115	A10/AP	165	DQ49
16	V <sub>SS</sub>	66	DQ30	116	BA1	166	DQ53
17	DQ3	67	DQ27	117	BA0	167	V <sub>CC</sub>
18	DQ7	68	DQ31	118	RAS#	168	V <sub>CC</sub>
19	DQ8	69	V <sub>CC</sub>	119	WE#	169	DQS6
20	DQ12	70	V <sub>CC</sub>	120	CAS#	170	DM6
21	V <sub>CC</sub>	71	NC	121	CS0	171	DQ50
22	V <sub>CC</sub>	72	NC	122	NC	172	DQ54
23	DQ9	73	NC	123	NC	173	V <sub>SS</sub>
24	DQ13	74	NC	124	NC	174	V <sub>SS</sub>
25	DQS1	75	V <sub>SS</sub>	125	V <sub>SS</sub>	175	DQ51
26	DM1	76	V <sub>SS</sub>	126	V <sub>SS</sub>	176	DQ55
27	V <sub>SS</sub>	77	DQS8	127	DQ32	177	DQ56
28	V <sub>SS</sub>	78	DM8	128	DQ36	178	DQ60
29	DQ10	79	NC	129	DQ33	179	V <sub>CC</sub>
30	DQ14	80	NC	130	DQ37	180	V <sub>CC</sub>
31	DQ11	81	V <sub>CC</sub>	131	V <sub>CC</sub>	181	DQ57
32	DQ15	82	V <sub>CC</sub>	132	V <sub>CC</sub>	182	DQ61
33	V <sub>CC</sub>	83	NC	133	DQS4	183	DQ57
34	V <sub>CC</sub>	84	NC	134	DM4	184	DM7
35	CK0	85	NC	135	DQ34	185	V <sub>SS</sub>
36	V <sub>CC</sub>	86	NC	136	DQ38	186	V <sub>SS</sub>
37	CK0#	87	V <sub>SS</sub>	137	V <sub>SS</sub>	187	DQ58
38	V <sub>SS</sub>	88	V <sub>SS</sub>	138	V <sub>SS</sub>	188	DQ62
39	V <sub>SS</sub>	89	NC	139	DQ35	189	DQ59
40	V <sub>SS</sub>	90	V <sub>SS</sub>	140	DQ39	190	DQ63
41	DQ16	91	NC	141	DQ40	191	V <sub>CC</sub>
42	DQ20	92	V <sub>CC</sub>	142	DQ44	192	V <sub>CC</sub>
43	DQ17	93	V <sub>CC</sub>	143	V <sub>CC</sub>	193	SDA
44	DQ21	94	V <sub>CC</sub>	144	V <sub>CC</sub>	194	SA0
45	V <sub>CC</sub>	95	NC	145	DQ41	195	SCL
46	V <sub>CC</sub>	96	CKE0	146	DQ45	196	SA1
47	DQS2	97	NC	147	DQS5	197	V <sub>CCSPD</sub>
48	DM2	98	NC	148	DM5	198	SA2
49	DQ18	99	NC	149	V <sub>SS</sub>	199	V <sub>CCID</sub>
50	DQ22	100	A11	150	V <sub>SS</sub>	200	NC

**PIN NAMES**

A0 – A11	Address input (Multiplexed)
BA0-BA1	Bank Select Address
DQ0-DQ63	Data Input/Output
DQS0-DQS8	Data Strobe Input/Output
CK0	Clock input
CK0#	Clock input
CKE0	Clock Enable Input
CS0#	Chip select Input
RAS#	Row Address Strobe
CAS#	Column Address Strobe
WE#	Write Enable
DQM0-DQM8	Data-In Mask
V <sub>CC</sub>	Power Supply (2.5V)
V <sub>CCQ</sub>	Power Supply for DQS (2.5V)
V <sub>SS</sub>	Ground
V <sub>REF</sub>	Power Supply for Reference
V <sub>CCSPD</sub>	Serial EEPROM Power Supply (2.3V to 3.6V)
SDA	Serial data I/O
SCL	Serial clock
SA0-SA2	Address in EEPROM
V <sub>CCID</sub>	V <sub>CC</sub> Identification Flag
NC	No Connect

White Electronic Designs Corp. reserves the right to change products or specifications without notice.



FUNCTIONAL BLOCK DIAGRAM

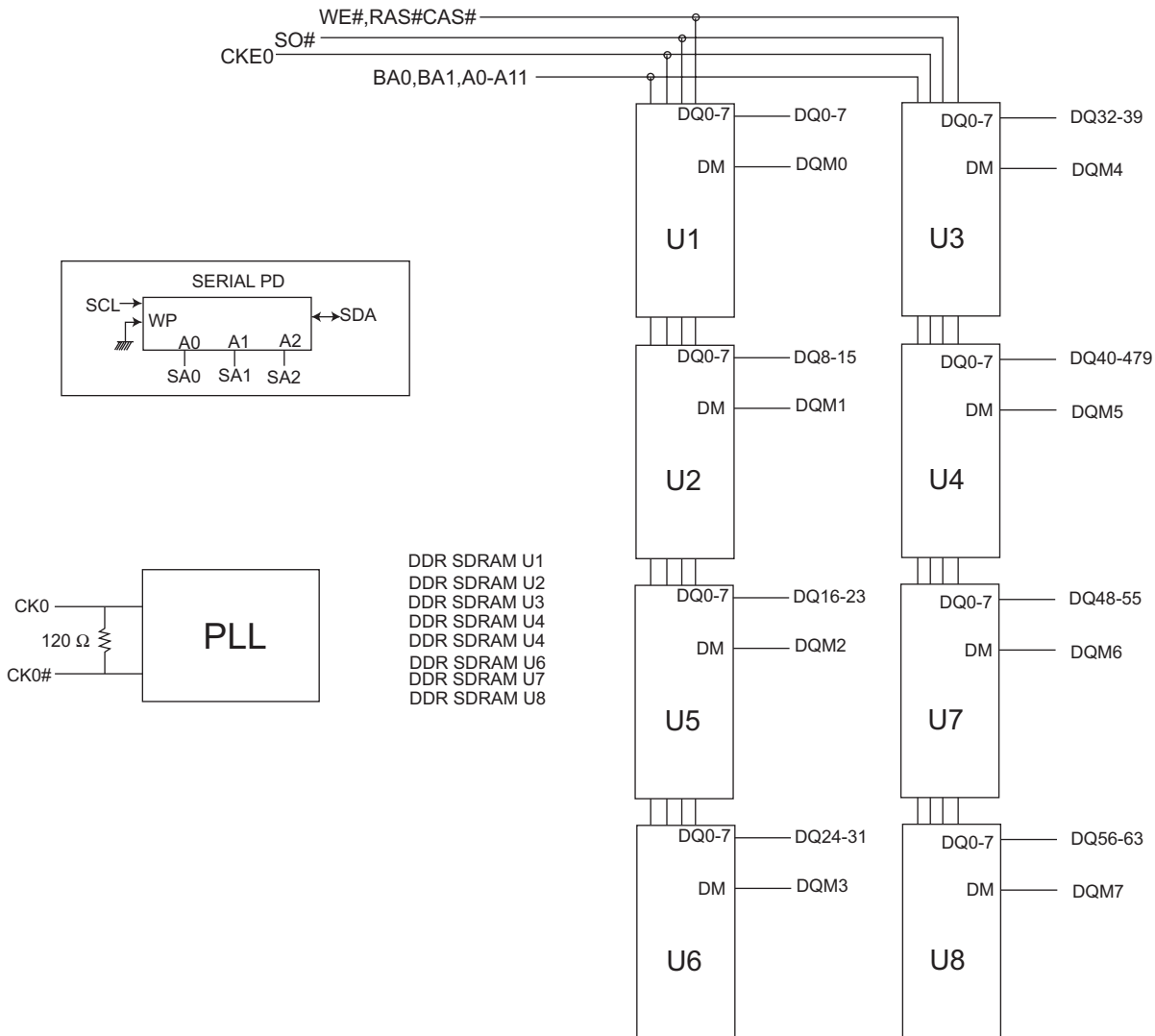

White Electronic Designs Corp. reserves the right to change products or specifications without notice.

Oct. 2002  
Rev. # 0



**Absolute Maximum Ratings**

Parameter	Symbol	Value	Units
Voltage on any pin relative to V <sub>SS</sub>	V <sub>IN</sub> , V <sub>OUT</sub>	-0.5 ~ 3.6	V
Voltage on V <sub>CC</sub> supply relative to V <sub>SS</sub>	V <sub>CC</sub> , V <sub>CCQ</sub>	-1.0 ~ 3.6	V
Storage Temperature	T <sub>STG</sub>	-55 ~ +150	°C
Power Dissipation	P <sub>D</sub>	8	W
Short Circuit Current	I <sub>OS</sub>	50	mA

Note:

Permanent device damage may occur if "ABSOLUTE MAXIMUM RATINGS" are exceeded.  
 Functional operation should be restricted to recommended operating condition.  
 Exposure to higher than recommended voltage for extended periods of time could affect device reliability.

**DC CHARACTERISTICS**

(t<sub>a</sub> = 0 to 70°C, V<sub>CC</sub> = 2.5V ± 0.2V)

Parameter	Symbol	Min	Max	Unit
Supply Voltage	V <sub>CC</sub>	2.3	2.7	V
Supply Voltage	V <sub>CCQ</sub>	2.3	2.7	V
Reference Voltage	V <sub>REF</sub>	V <sub>CCQ</sub> /2-50mV	V <sub>CCQ</sub> /2+50mV	V
Termination Voltage	V <sub>TT</sub>	V <sub>REF</sub> -0.04	V <sub>REF</sub> +0.04	V
Input High Voltage	V <sub>IH</sub>	V <sub>REF</sub> +0.15	V <sub>CCQ</sub> +0.3	V
Input Low Voltage	V <sub>IL</sub>	-0.3	V <sub>REF</sub> +0.15	V
Output High Voltage	V <sub>OH</sub>	V <sub>TT</sub> +0.76	—	V
Output Low Voltage	V <sub>OL</sub>	—	V <sub>TT</sub> -0.76	V

**CAPACITANCE**

(t<sub>a</sub> = 23°C, f = 1MHz, V<sub>CC</sub> = 3.3V, V<sub>REF</sub>=1.4V ± 200mV)

Parameter	Symbol	Min	Max	Unit
Input Capacitance (A0-A12)	C <sub>IN1</sub>	-	34	pF
Input Capacitance (RAS#,CAS#,WE#)	C <sub>IN2</sub>	-	34	pF
Input Capacitance (CKE0)	C <sub>IN3</sub>	-	34	pF
Input Capacitance (CK0, CK0#)	C <sub>IN4</sub>	-	30	pF
Input Capacitance (CS0#)	C <sub>IN5</sub>	-	30	pF
Input Capacitance (DQM0-DQM8)	C <sub>IN6</sub>	-	10	pF
Input Capacitance (BA0-BA1)	C <sub>IN7</sub>	-	45	pF
Data input/output capacitance (DQ0-DQ63)(DQS)	C <sub>OUT</sub>	-	10	pF

White Electronic Designs Corp. reserves the right to change products or specifications without notice.

**I<sub>DD</sub> SPECIFICATIONS AND TEST CONDITIONS**

(Recommended operating conditions, t<sub>a</sub> = 0 to 70°C, V<sub>CC0</sub> = 2.5V ± 0.2V, V<sub>CC</sub> = 2.5V ± 0.2V)

Parameter	Symbol	Conditions	DDR333@CL=2.5 Max	DDR266@CL=2, 2.5 Max	DDR200@CL=2 Max	Units
Operating Current	I <sub>DD0</sub>	One device bank; Active = Precharge; t <sub>RC</sub> =t <sub>RC</sub> (MIN); t <sub>CK</sub> =t <sub>CK</sub> (MIN); DQ, DM and DQS inputs changing once per clock cycle; Address and control inputs changing once every two cycles.	840	760	680	mA
Operating Current	I <sub>DD1</sub>	One device banks; Active-Read-Precharge; Burst = 2; t <sub>RC</sub> =t <sub>RC</sub> (MIN); t <sub>CK</sub> =t <sub>CK</sub> (MIN); I <sub>OUT</sub> =0mA; Address and control inputs changing once per clock cycle.	1040	960	880	mA
Precharge Power-Down Standby Current	I <sub>DD2P</sub>	All device bank idle; Power-down mode; t <sub>CK</sub> =t <sub>CK</sub> (MIN); CKE=(low)	24	24	24	mA
Idle Standby Current	I <sub>DD2F</sub>	CS# = High; All device banks idle; t <sub>CK</sub> =t <sub>CK</sub> (MIN); CKE = high; Address and other control inputs changing once per clock cycle. V <sub>IN</sub> = V <sub>REF</sub> for DQ, DQS and DM.	200	180	160	mA
Active Power-Down Standby Current	I <sub>DD3P</sub>	One device bank active; Power-down mode; t <sub>CK</sub> (MIN); CKE=(low)	280	280	225	mA
Active Standby Current	I <sub>DD3N</sub>	CS# = High; CKE = High; One device bank; Active-Precharge; t <sub>RC</sub> =t <sub>RAS</sub> (MAX); t <sub>CK</sub> =t <sub>CK</sub> (MIN); DQ, DM and DQS inputs changing twice per clock cycle; Address and other control inputs changing once per clock cycle	495	440	360	mA
Operating Current	I <sub>DD4R</sub>	Burst = 2; Reads; Continous burst; Once device bank active; Address and control inputs changing once per clock cycle; t <sub>CK</sub> =t <sub>CK</sub> (MIN); I <sub>OUT</sub> =0mA	1280	1140	960	mA
Operating Current	I <sub>DD4W</sub>	Burst=2; Writes; Continous burst; Once device bank active; Address and control inputs changing once per clock cycle; t <sub>CK</sub> =t <sub>CK</sub> (MIN); DQ,DM and DQS inputs changing twice per clock cycle.	1216	1040	815	mA
Auto Refresh Current	I <sub>DD5</sub>	t <sub>RC</sub> =t <sub>RC</sub> (MIN)	1520	1440	1315	mA
Self Refresh Current	I <sub>DD6</sub>	CKE £ 0.2V	16	16	16	mA
Operating Current	I <sub>DD7A</sub>	Four bank interleaving Reads (BL=4) with auto precharge with t <sub>RC</sub> =t <sub>RC</sub> (MIN); t <sub>CK</sub> =t <sub>CK</sub> (MIN); Address and control input change only during Active Read or Write commands.	2640	2400	1920	mA

\* Module I<sub>DD</sub> was calculated on the basis of component I<sub>DD</sub> and can be different measured according to DQ loading cap.



## DETAILED TEST CONDITIONS FOR DDR SDRAM I<sub>DD1</sub> & I<sub>DD7A</sub>

### I<sub>DD1</sub> : OPERATING CURRENT: ONE BANK

1. Typical Case : V<sub>CC</sub> = 2.5V, T = 25°C
2. Worst Case : V<sub>CC</sub> = 2.7V, T = 10°C
3. Only one bank is accessed with t<sub>RC</sub> (min), Burst Mode, Address and Control inputs on NOP edge are changing once per clock cycle.

I<sub>OUT</sub> = 0mA

#### 4. Timing patterns

-DDR200 (100Mhz, CL = 2) : t<sub>CK</sub> = 10ns, CL2, BL = 4, t<sub>RCD</sub> = 2\*t<sub>CK</sub>, t<sub>RAS</sub> = 5\*t<sub>CK</sub>  
 Read : A0 N R0 N N P0 N A0 N - repeat the same timing with random address changing; 50% of data changing at every burst

-DDR266B (133Mhz, CL = 2.5) : t<sub>CK</sub> = 7.5ns, CL = 2.5, BL = 4, t<sub>RCD</sub> = 3\*t<sub>CK</sub>, t<sub>RC</sub> = 9\*t<sub>CK</sub>, t<sub>RAS</sub> = 5\*t<sub>CK</sub>  
 Read : A0 N N R0 N P0 N N A0 N - repeat the same timing with random address changing; 50% of data changing at every burst

-DDR266A (133Mhz, CL = 2) : t<sub>CK</sub> = 7.5ns, CL = 2, BL = 4, t<sub>RCD</sub> = 3\*t<sub>CK</sub>, t<sub>RC</sub> = 9\*t<sub>CK</sub>, t<sub>RAS</sub> = 5\*t<sub>CK</sub>  
 Read : A0 N N R0 N P0 N N A0 N - repeat the same timing with random address changing; 50% of data changing at every burst

-DDR333 (166MHz, CL = 2.5) : t<sub>CK</sub> = 6ns, CL = 2.5, BL = 4, t<sub>RCD</sub> = 10\*t<sub>CK</sub>, t<sub>RAS</sub> = 7\*t<sub>CK</sub>  
 Read " A0 N N R0 N P0 N N A0 N - repeat the same timing with random address changing; 50% of data changing at every burst.

### I<sub>DD7A</sub> : OPERATING CURRENT : FOUR BANK OPERATION

1. Typical Case : V<sub>CC</sub> = 2.5V, T = 25°C
2. Worst Case : V<sub>CC</sub> = 2.7V, T = 10°C
3. Four banks are being interleaved with t<sub>RC</sub> (min), Burst Mode, Address and Control inputs on NOP edge are not changing.

I<sub>OUT</sub> = 0mA

#### 4. Timing patterns

- DDR200 (100Mhz, CL = 2) : t<sub>CK</sub> = 10ns, CL2, BL = 4, t<sub>RRD</sub> = 2\*t<sub>CK</sub>, t<sub>RCD</sub> = 3\*t<sub>CK</sub>, Read with autoprecharge  
 Read : A0 N A1 R0 A2 R1 A3 R2 A0 R3 A1 R0 - repeat the same timing with random address changing; 100% of data changing at every burst

-DDR266B (133Mhz, CL = 2.5) : t<sub>CK</sub> = 7.5ns, CL = 2.5, BL = 4, t<sub>RRD</sub> = 2\*t<sub>CK</sub>, t<sub>RCD</sub> = 3\*t<sub>CK</sub>  
 Read with autoprecharge  
 Read : A0 N A1 R0 A2 R1 A3 R2 N R3 A0 N A1 R0 - repeat the same timing with random address changing; 100% of data changing at every burst

-DDR266A (133Mhz, CL = 2) : t<sub>CK</sub> = 7.5ns, CL2 = 2, BL = 4, t<sub>RRD</sub> = 2\*t<sub>CK</sub>, t<sub>RCD</sub> = 3\*t<sub>CK</sub>  
 Read : A0 N A1 R0 A2 R1 A3 R2 N R3 A0 N A1 R0 - repeat the same timing with random address changing; 100% of data changing at every burst

-DDR333 (166MHz, CL = 2.5) : t<sub>CK</sub> = 6ns, CL = 2.5, BL = 4, t<sub>RRD</sub> = 2\*t<sub>CK</sub>, t<sub>RCD</sub> = 3\*t<sub>CK</sub>, Read with autoprecharge  
 Read : A0 N A1 R0 A2 R1 A3 R2 N R3 A0 N A1 R0 - repeat the same timing with random address changing; 100% of data changing at every burst

Legend : A = Activate, R = Read, W = Write, P = Precharge, N = NOP



ORDER INFORMATION

Part Number	Speed	CAS Latency
WED3EG6418S335D4	166MHz/333Mbps	CL=2.5
WED3EG6418S262D4	133MHz/266Mbps	CL=2
WED3EG6418S265D4	133MHz/266Mbps	CL=2.5
WED3EG6418S202D4	100MHz/200Mbps	CL=2

PACKAGE DIMENSIONS

ALL DIMENSIONS ARE IN INCHES

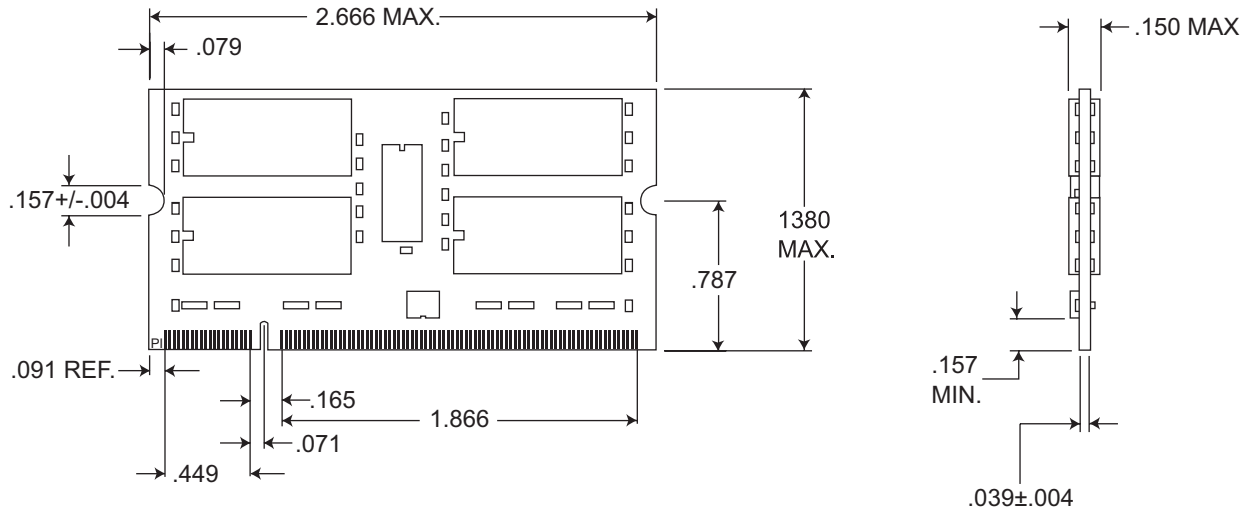

White Electronic Designs Corp. reserves the right to change products or specifications without notice.

Oct. 2002  
Rev. # 0