



# Winstar Display Co., LTD

## 華凌光電股份有限公司

住址: 407 台中市清路 163 號  
No.163 Chung Ching RD.,  
Taichune, Taiwan, R.O.C

WEB: <http://www.winstar.com.tw>  
E-mail: sales@winstar.com.tw  
Tel:886-4-24262208 Fax : 886-4-24262207



### SPECIFICATION

**CUSTOMER :** \_\_\_\_\_

**MODULE NO.:** **WF70ATIAGDO#000**

<b>APPROVED BY:</b>  ( FOR CUSTOMER USE ONLY )	<b>PCB VERSION:</b>	<b>DATA:</b>

SALES BY	APPROVED BY	CHECKED BY	PREPARED BY

VERSION	DATE	REVISED PAGE NO.	SUMMARY
H	2012.02.08	5	Add View Direction

**RECORDS OF REVISION**

DOC. FIRST ISSUE

VERSION	DATE	REVISED PAGE NO.	SUMMARY
0	2009/9/18		First issue
A	2010.02.23	18	Add Touch panel Information
B	2010.03.09	16	Correct interface
C	2010/04/21	11	Modify Touch Panel Specifications
D	2011.07.21	15	Update the length of the TS-FPC=61.7mm.
E	2011.09.02	15	Update the length of the TS-FPC=60.0mm.
F	2011.11.02	15	Update the length of the TS-FPC=61.7mm.
H	2012.02.08	5	Add View Direction

# **Contents**

1.Module Classification Information

2.Summary

3. Features

4.General Specification

5. Interface

6. Absolute Maximum Ratings

7. Electrical Characteristics

8. Electro-optical Characteristics

9. Contour drawing

10.Backlight Information

11.Touch panel Information

12. Reliability Test



## **2 . Summary**

This technical specification applies to 7" TFT-LCD module with a LED Backlight unit and a 40-pin TTL interface. This module supports 800\*R.G.B x 480 WVGA mode and can display 262,144 colors.

## **3 . Features**

- Thin and Light Weight.
- WVGA(800x480 pixels) resolution.
- 3.3 V TTL interface

## **4.General Specification**

<b>Parameter</b>	<b>Specifications</b>	<b>Unit</b>
Screen size	7"(Diagonal)	inch
Display Resolution	800 RGB x 480	pixel
Active area	152.4x91.44	mm
Dot Pitch	63.5 x 190.5	um
Pixel size	190.5 x 190.5	um
Surface treatment	Anti-glare	
Color Saturation (NTSC)	45	%
Pixel Configuration	RGB Vertical Stripe	
Outline dimension	165(W) x 104.44(H) x7.09 (D)	mm
Weight	TBD	g
View Direction	12 o'clock	--
Gray Scale Inversion Direction	6 o'clock	
Interface Type	TTL	--
LCD Type	TN	--
Color Depth	262,144	colors

## 5 . Interface

### LCM PIN Definition

Pin No.	Symbol	Description	Remark
1	GND	Power ground	
2	GND	Power ground	
3	NC	Not connect	
4	VCC	Power supply for Digital Circuit	
5	VCC	Power supply for Digital Circuit	
6	VCC	Power supply for Digital Circuit	
7	VCC	Power supply for Digital Circuit	
8	NC	Not connect	
9	DE	Data enable signal	
10	GND	Power ground	
11	GND	Power ground	
12	GND	Power ground	
13	B5	Blue Data 5 (MSB)	
14	B4	Blue Data 4	
15	B3	Blue Data 4	
16	GND	Power ground	
17	B2	Blue Data 2	
18	B1	Blue Data 1	
19	B0	Blue Data 0 (LSB)	
20	GND	Power ground	
21	G5	Green Data 5 (MSB)	
22	G4	Green Data 4	
23	G3	Green Data 4	
24	GND	Power ground	
25	G2	Green Data 2	
26	G1	Green Data 1	
27	G0	Green Data 0 (LSB)	
28	GND	Power ground	
29	R5	Red Data 5 (MSB)	
30	R4	Red Data 4	
31	R3	Red Data 4	
32	GND	Power ground	
33	R2	Red Data 2	
34	R1	Red Data 1	
35	R0	Red Data 0 (LSB)	
36	GND	Power ground	
37	GND	Power ground	
38	DCLK	Clock Signals; Latch Data at the falling edge	
39	GND	Power ground	
40	GND	Power ground	

Note: User's connector part number is **PF050-40ZSG-F09-S** manufactured by UJU or equivalent.

## Backlight Driving Part

Pin No.	Symbol	Description
1	VLED+	Red, LED_ Anode
2	VLED-	White, LED_ Cathode

Note: The backlight interface connector is a model **BHSR-02VS-1** manufactured by JST or equivalent. The matching connector part number is **SM02B-BHSS-1-TB** manufactured by JST or equivalent.

## 6 . Absolute Maximum Ratings

Item	Symbol	Condition	Min.	Max.	Unit	Remark
Power Voltage	V <sub>cc</sub>	GND=0	-0.3	6	V	-
Input logic	V <sub>i</sub>	GND=0	-0.3	V <sub>cc</sub> +0.3	V	Note 1

Note 1: DCLK, DE, R0~ R5, G0~ G5, B0~ B5.

## 7. Electrical Characteristics

Recommended Operation condition (GND=0V , Ta=25°C)

Parameter	Symbol	Rating			Unit	Condition
		Min	TYP	max		
Power Supply	VCC	3.0	3.3	3.6	V	
Input logic voltage	High level	V <sub>ih</sub>	0.7V <sub>cc</sub>	vcc	V	Note1
	Low level	v <sub>il</sub>	0	0.3vcc	V	Note1

Note 1: DCLK, DE, R0~ R5, G0~ G5, B0~ B5.

TFT-LCD current consumption

Parameter	Symbol	Rating			Unit	Condition
		Min	TYP	max		
LCD power current	I <sub>cc</sub>	-	200	260	mA	black pattern
LED power current	I <sub>LED</sub>	-	160	200	mA	



## AC CHARACTERISTICS

### 7.1 AC Electrical CHARACTERISTICS

Frame rate range : 60Hz~65Hz

Parameter	Symbol	Rating			Unit
		Min	TYP	max	
Data setup time	Tdsu	6			ns
Data hold time	Tdhd	6			ns
DE setup time	Tesu	6			ns
CLK frequency	F <sub>CPH</sub>	29.4	33.26	42.48	MHz
CLK period	T <sub>CPH</sub>	23.54	30.06	34.01	ns
CLK pulse duty	T <sub>CWH</sub>	40	50	60	%
CLK pulse duty	T <sub>cwl</sub>	40	50	60	%
DE period	T <sub>DEH+TDEL</sub>	1000	1056	1200	T <sub>CPH</sub>
DE pulse width	T <sub>DEH</sub>		800		T <sub>CPH</sub>
DE frame blanking	T <sub>DEB</sub>	10	45	110	T <sub>DEH+TDEL</sub>
DE frame width	T <sub>DE</sub>		480		T <sub>DEH+TDEL</sub>

Note : We suggest using the typical value, so it can have better performance.

## 7.2 Timing Controller Timing Chart

### Clock and Data input waveforms

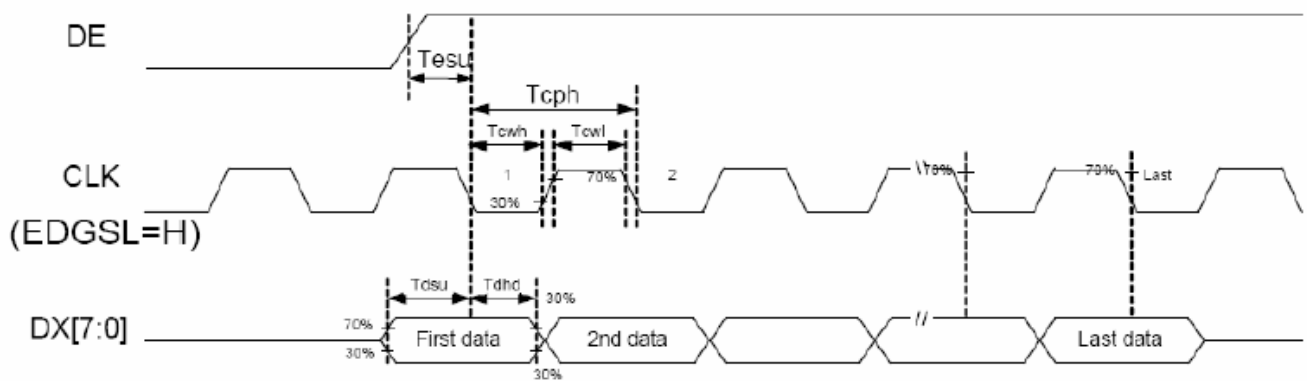

### Data input format

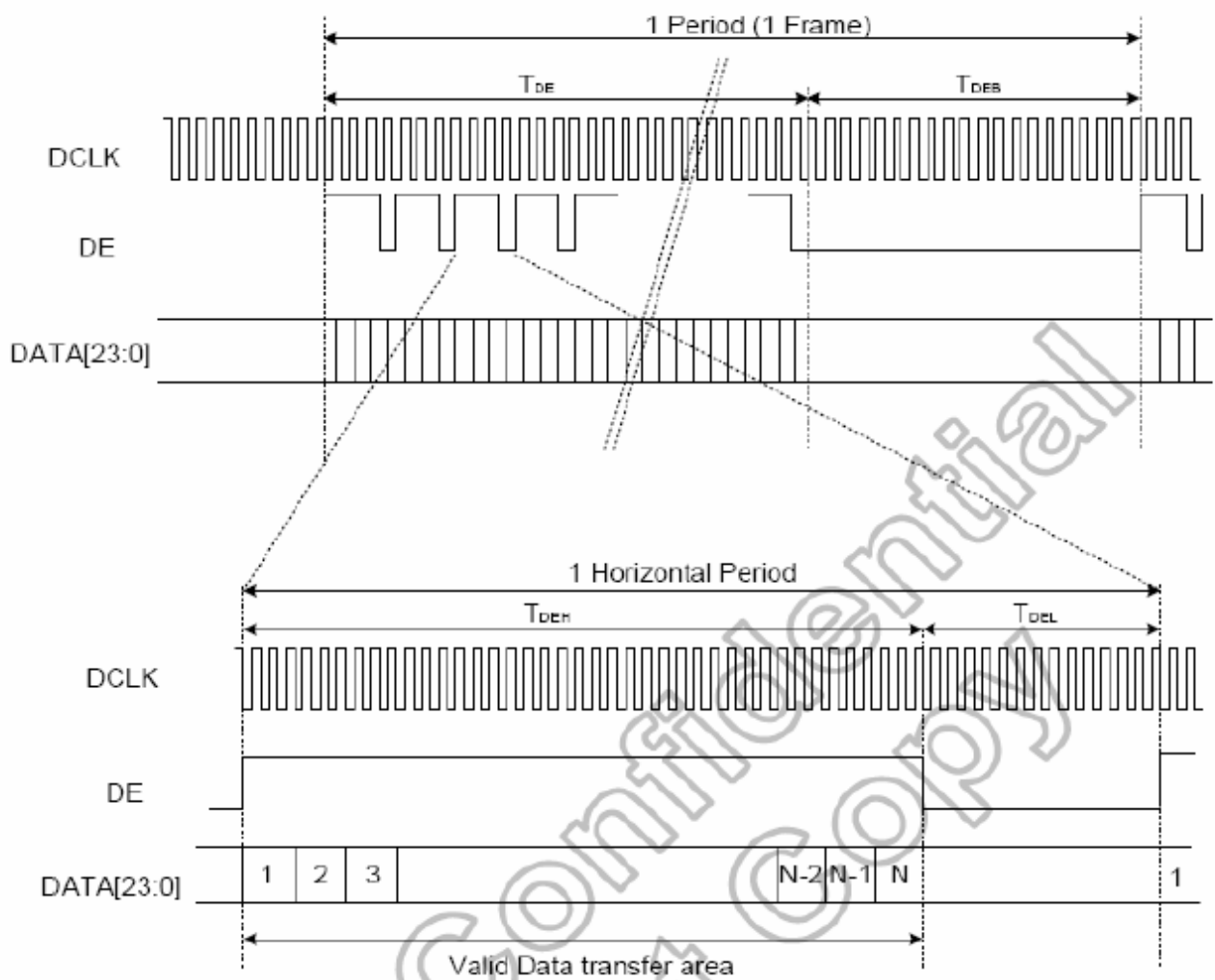

### Power ON/OFF sequence

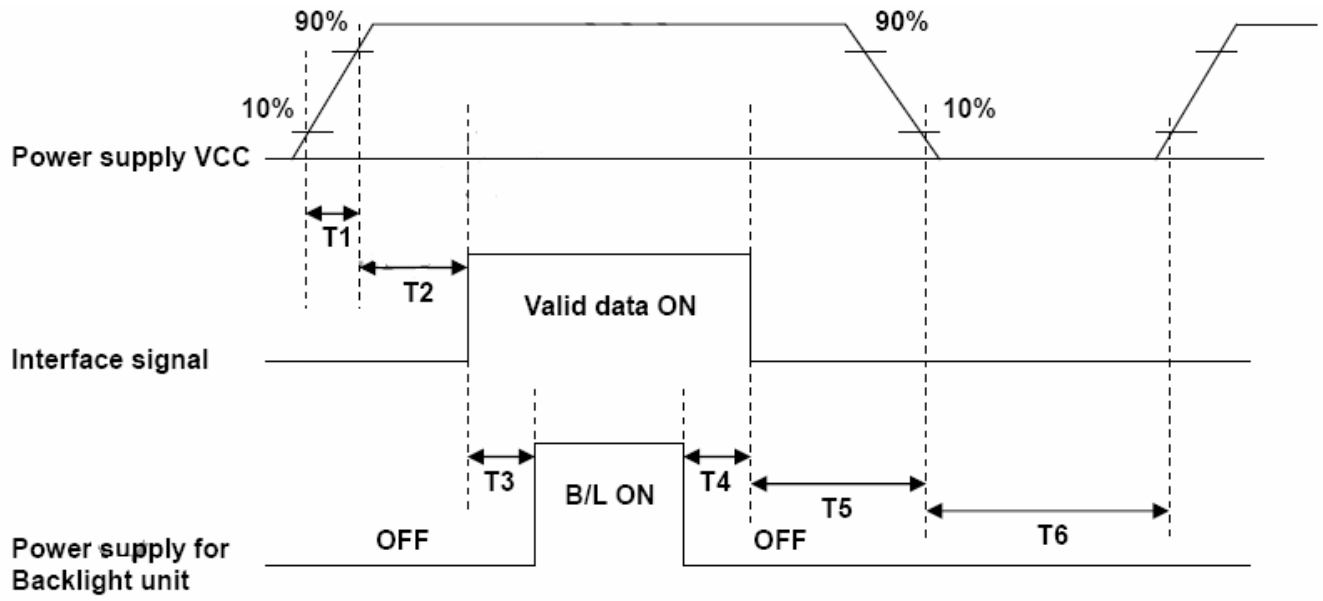

Parameter	SPEC.			Unit
	Min.	Typ.	Max.	
T1	1		2	ms
T2	0	60		ms
T3	200			ms
T4	200			ms
T5	1			ms
T6	1000			ms

## 8. Electro-optical Characteristics

Item	Symbol	Condition	Min.	Typ.	Max.	Unit	Remark
Brightness	-	Viewing normal angle $\theta = \phi = 0^\circ$	300	350	-	cd/m <sup>2</sup>	Center of display
Response time	Tr		-	5	10	.ms	Note 3,5
	Tf		-	11	16	.ms	
Contrast ratio	CR		250	400	-	-	Note 4,5
Color Chromaticity	White		Wx	0.249	0.299	0.349	-
		Wy	0.278	0.328	0.378		
Viewing angle	Hor.	$\theta_R$	60	70	-	Deg.	Note 1
		$\theta_L$	60	70	-		
	Ver.	$\phi_T$	50	60	-		
		$\phi_B$	60	70	-		

Note 1: Definition of viewing angle range

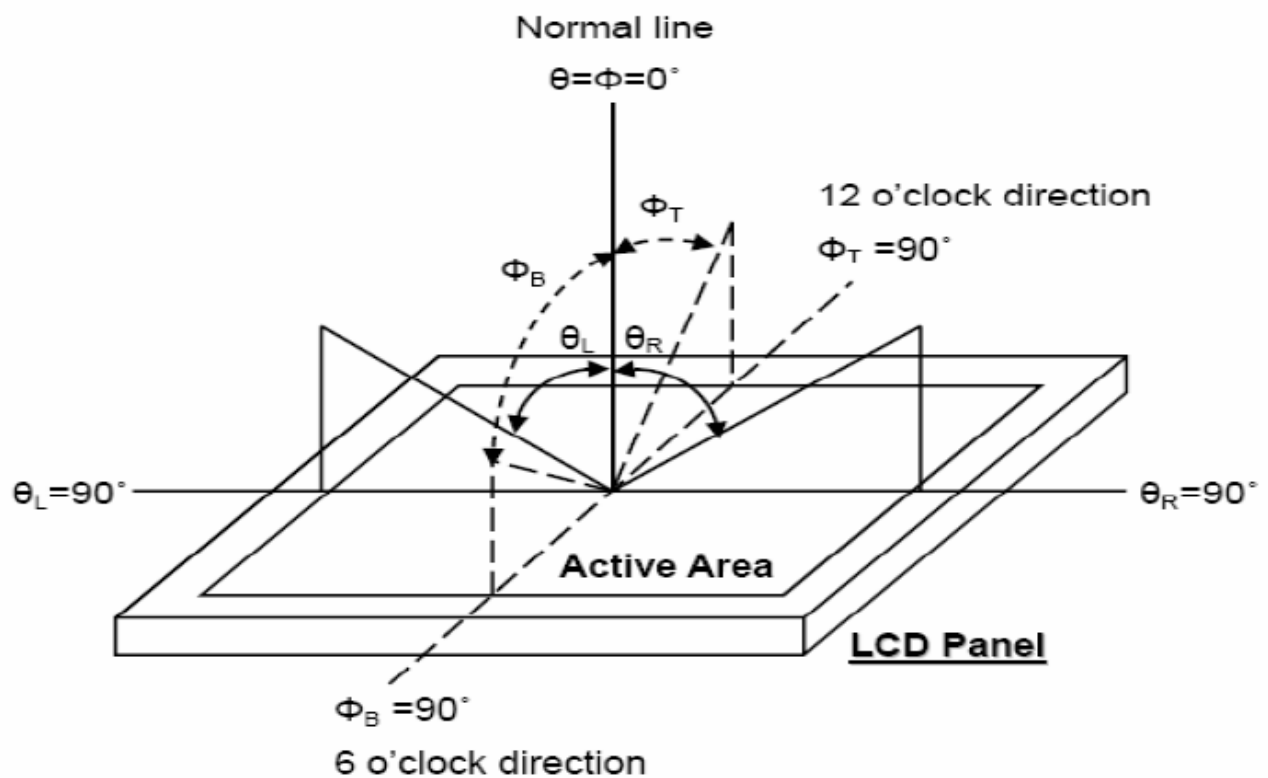

Note 2: Test equipment setup:

After stabilizing and leaving the panel alone at a driven temperature for 10 minutes, the measurement should be executed. Measurement should be executed in a stable, windless, and dark room. Optical specifications are measured by Topcon BM-7 luminance meter 1.0° field of view at a distance of 50cm and normal direction.

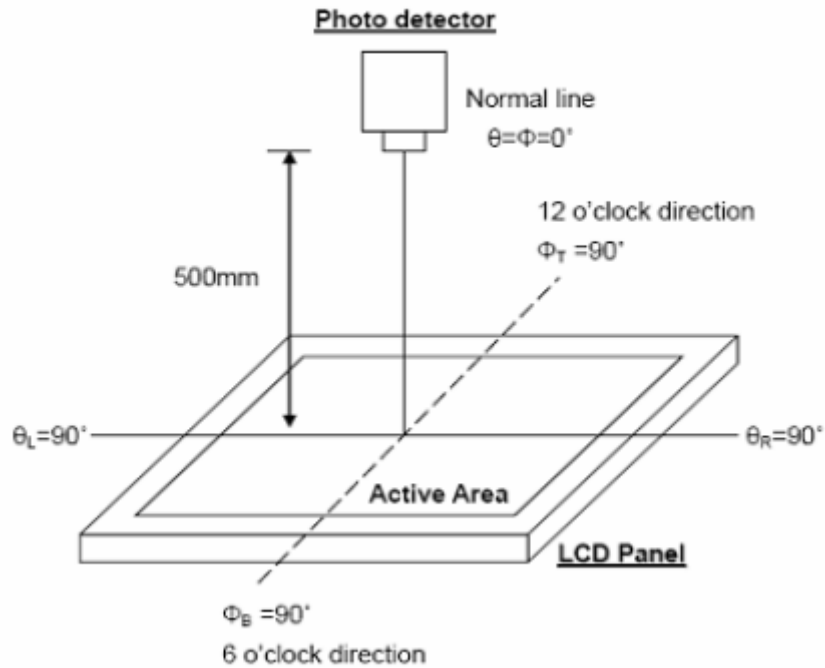

Optical measurement system setup

Note 3: Definition of Response time:

The response time is defined as the LCD optical switching time interval between “White state and “Black” state. Rise time,  $T_r$ , is the time between photo detector output intensity changed from 90% to 10% . And fall time,  $T_f$ , is the time between photo detector output Intensity changed from 10% to 90% .

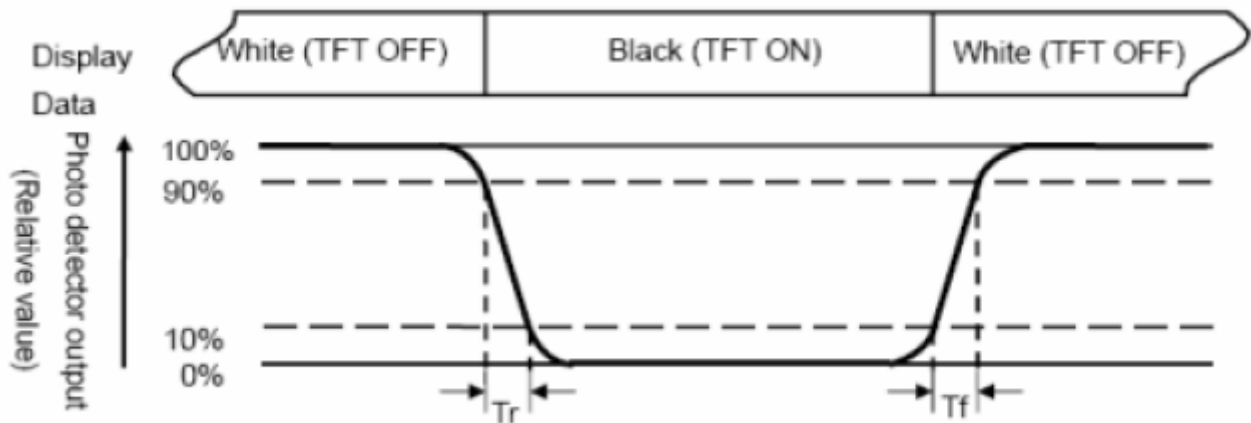

Fig. 3-3 Definition of response time

Note 4: Definition of contrast ratio:

The contrast ratio is defined as the following expression.

$$\text{Contrast ratio (CR)} = \frac{\text{Luminance measured when LCD on the "White" state}}{\text{Luminance measured when LCD on the "Black" state}}$$

Note 5: White  $V_i = V_{i50} \pm 1.5V$

Black  $V_i = V_{i50} \pm 2.0V$

“±” means that the analog input signal swings in phase with VCOM signal.

“±” means that the analog input signal swings out of phase with VCOM signal.

The 100% transmission is defined as the transmission of LCD panel when all the input terminals of module are electrically opened.

Note 6: Definition of color chromaticity (CIE 1931)

Color coordinates measured at the center point of LCD

Note 7: Measured at the center area of the panel when all the input terminals of LCD panel are electrically opened.

$$\text{Note 8 : Uniformity (U)} = \frac{\text{Brightness (min)}}{\text{Brightness (max)}} \times 100\%$$

# 9. Contour Drawing

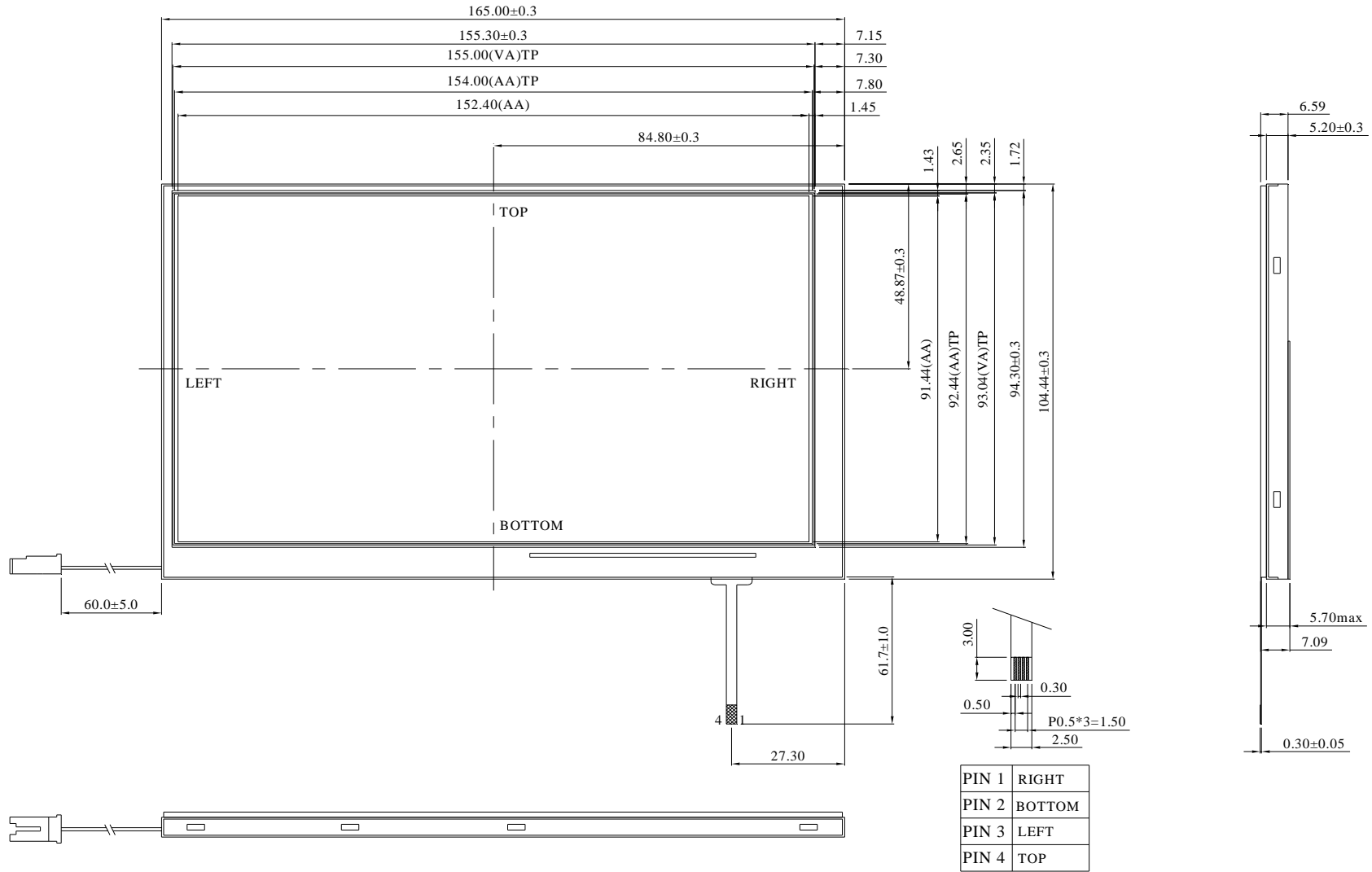

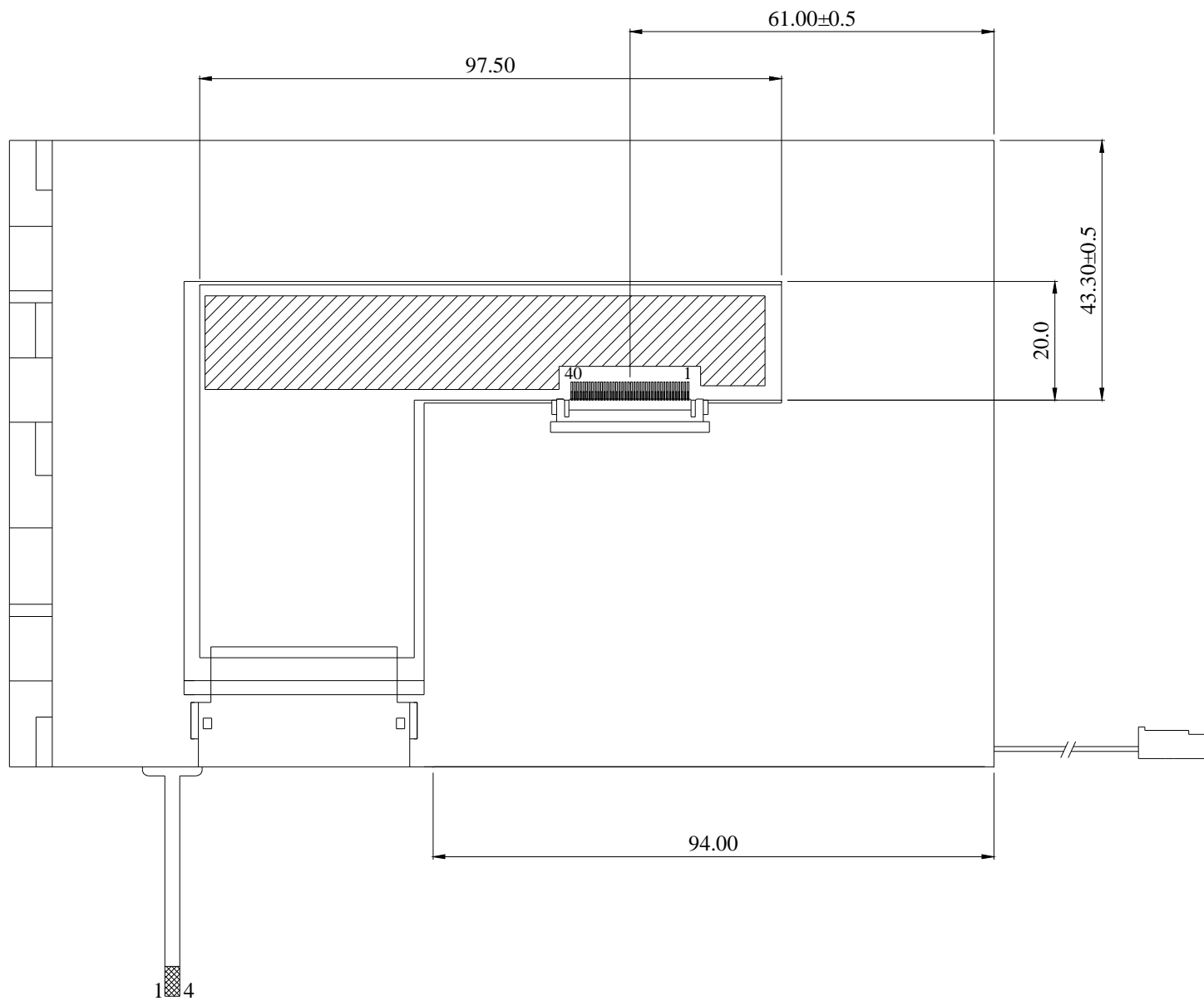

PIN NO.	SYMBOL	PIN NO.	SYMBOL
1	GND	21	G5
2	GND	22	G4
3	NC	23	G3
4	VCC	24	GND
5	VCC	25	G2
6	VCC	26	G1
7	VCC	27	G0
8	NC	28	GND
9	DE	29	R5
10	GND	30	R4
11	GND	31	R3
12	GND	32	GND
13	B5	33	R2
14	B4	34	R1
15	B3	35	R0
16	GND	36	GND
17	B2	37	GND
18	B1	38	DCLK
19	B0	39	GND
20	GND	40	GND



# 10. Backlight Information

## Specification

Parameter	Symbol	Min.	Typ.	Max.	Unit	Remark
LED current	I <sub>LED</sub>	-	160	-	mA	Note 1
LED voltage	V <sub>LED</sub>	-	9.9	-	V	
LED Life Time	-	10,000	20,000	-	Hr	Note 2

Note 1 : There are 8 Groups LED shown as below , V<sub>LED</sub>=9.9V , I<sub>LED</sub>=160mA.

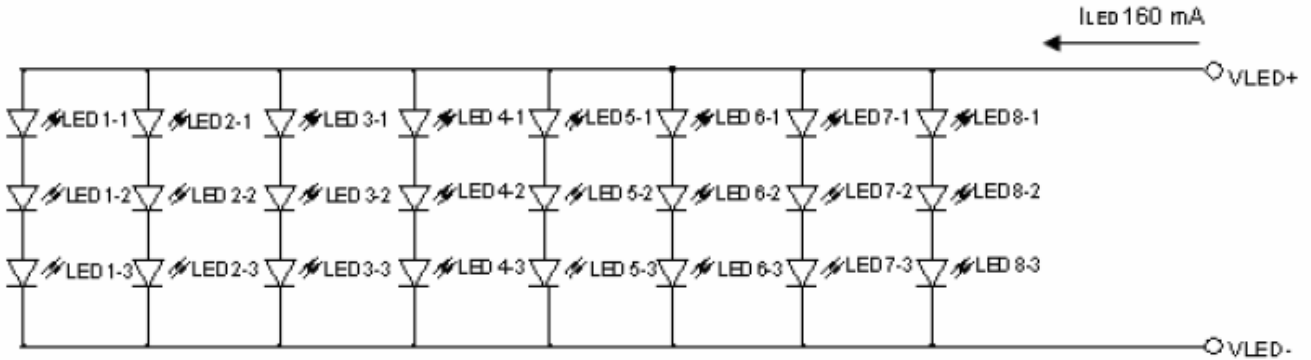

Note 2 : Brightness to be decreased to 50% of the initial value.

# 11.Touch panel Information

## 11.1 Block diagram

Block diagram

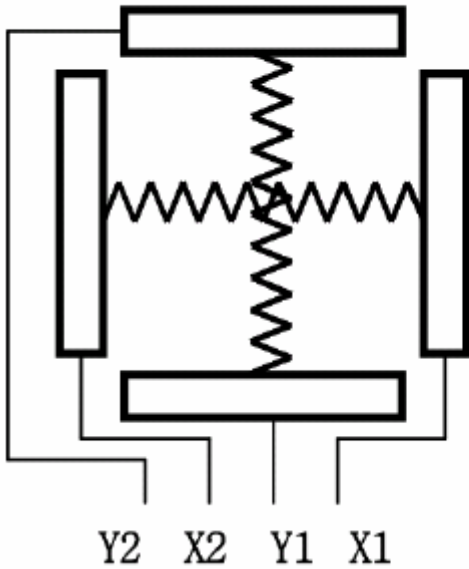

Top View

X : Upper electrode  
Y : Lower electrode

Pin	Symbol	I/O	Function
1	X1	Right	Right electrode - differential analog
2	Y1	Bottom	Bottom electrode - differential analog
3	X2	Left	Left electrode - differential analog
4	Y2	Top	Top electrode - differential analog

## 11.2 Absolute maximum ratings

Item	Symbol	Values-		Unit	condition
		Min	Max		
Power voltage	V <sub>cc</sub>	-0.3	7.0	V	GND=0
Input signal voltage	V <sub>i</sub>	-0.3	V <sub>cc</sub> +0.3	V	

### 11.3 Electrical characteristics

Item	Min.	Typ.	Max.	Unit	Note
Linearity	-	-	1.5	%	
Terminal Resistance	500	-	1100	$\Omega$	X (Film side)
	100	-	500	$\Omega$	Y (Film side)
Insulation resistance	20	-	-	M $\Omega$	At DC 25V, 60sec
Voltage	-	-	5	V	DC
Chattering	-	-	10	ms	ON/OFF
Transparency	84	-	-	%	Non-glare
Haze rate	5	7	9	%	

Note: Do not operate it with a thing except a polyacetal pen (tip R0.8mm or less) or a finger, especially those with hard or sharp tips such as a ball point pen or a mechanical pencil.

### 11.4 Mechanical characteristics

Item	Min.	Typ.	Max.	Unit	Note
Activation force	-	-	100	g	(1)
Durability-surface scratching	Write 100,000	-	-	characters	(2)
Durability-surface pitting	1,000,000	-	-	touches	(3)
Surface hardness	3	-	-	H	JIS K5600-5-4

Note1: Stylus pen Input : R0.8mm polyacetal pen or Finger

Note2: Measurement for Surface area

Scratch 100,000 times straight lines on the Film with a stylus change every 20,000times.

Force= 150gf. Speed= 60mm/sec.

Stylus= R0.8 polyacetal tip.

Note3: Pit 1,000,000 times on the Film with a R8.0 silicon rubber

### ***Non-Proper Ways to handle the touch screen***

1. Do not pull or crease the tail of the touch screen.

Tails, unless the drawing calls out for a bend, are to be free of permanent creases in the polyester, slight crease lines in the adhesive tail cover are allowed

## **12. RELIABILITY TEST**

### WIDE TEMPERATURE RELIABILITY TEST

N O.	ITEM	CONDITION			STANDARD	NOTE
1	High Temp. Storage	80°C	240 Hrs		Appearance without defect	
2	Low Temp. Storage	-30°C	240 Hrs		Appearance without defect	
3	High Temp. & High Humi. Storage	60 °C 90%RH	240 Hrs		Appearance without defect	
4	High Temp. Operating Display	70°C	240 Hrs		Appearance without defect	
5	Low Temp. Operating Display	-20°C	240 Hrs		Appearance without defect	
6	Thermal Shock	-20 °C, 30min. → 70°C, 30min. ↑ (1cycle) ↓			Appearance without defect	10 cycles

# Inspection Provision

## 1.Purpose

The WINSTAR inspection provision provides outgoing inspection provision and its expected quality level based on our outgoing inspection of WINSTAR LCD produces.

## 2.Applicable Scope

The WINSTAR inspection provision is applicable to the arrangement in regard to outgoing inspection and quality assurance after outgoing.

## 3.Technical Terms

### 3-1 WINSTAR Technical Terms



## 4.Outgoing Inspection

### 4-1 Inspection Method

MIL-STD-105E Level II Regular inspection

### 4-2 Inspection Standard

		Item	AQL(%)	Remarks
Major Defect	Dots	Opens Shorts Erroneous operation	0.4	Faults which substantially lower the practicality and the initial purpose difficult to achieve
	Solder appearance	Shorts Loose		
	Cracks	Display surface cracks		

	Dimensions	External from Dimensions	0.4	
Minor Defect	Inside the glass	Black spots	0.65	Faults which appear to pose almost no obstacle to the practicality, effective use, and operation
	Polarizing plate	Scratches, foreign Matter, air bubbles, and peeling		
	Dots	Pinhole, deformation		
	Color tone	Color unevenness		
	Solder appearance	Cold solder Solder projections		

#### 4-3 Inspection Provisions

##### \*Viewing Area Definition

Fig. 1

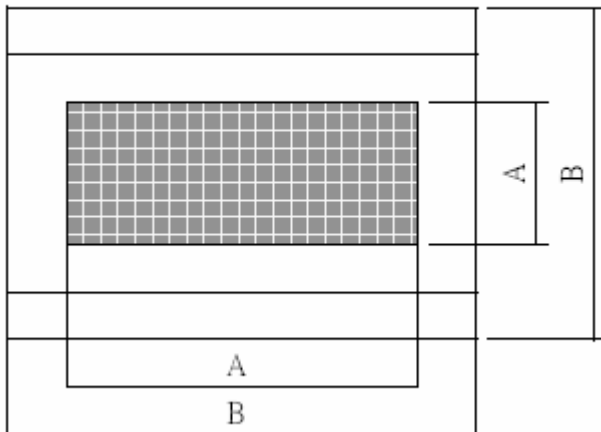

A : Zone Viewing Area

B : Zone Glass Plate Outline

\*Inspection place to be 500 to 1000 lux illuminance uniformly without glaring.

The distance between luminous source(daylight fluorescent lamp and cool white fluorescent lamp) and sample to be 30 cm to 50 cm.

\*Test and measurement are performed under the following conditions, unless otherwise specified.

Temperature  $20 \pm 15^{\circ}\text{C}$

Humidity  $65 \pm 20\% \text{R.H.}$

Pressure 860~1060hPa(mmbar)

In case of doubtful judgment, it is performed under the following conditions.

Temperature  $20 \pm 2^{\circ}\text{C}$

Humidity  $65 \pm 5\% \text{R.H.}$

Pressure 860~1060hPa(mmbar)

## 5.Specification for quality check

### 5-1-1 Electrical characteristics :

NO.	Item	Criterion
1	Non operational	Fail
2	Miss operating	Fail
3	Contrast irregular	Fail
4	Response time	Within Specified value

### 5-1-2 Components soldering :

Should be no defective soldering such as shorting, loose terminal cold solder, peeling of printed circuit board pattern, improper mounting position, etc.

## 5-2 Inspection Standard for TFT panel

### 5-2-1 The environmental condition of inspection :

The environmental condition and visual inspection shall be conducted as below.

(1) Ambient temperature :  $25\pm 5^{\circ}\text{C}$

(2) Humidity : 25~75% RH

(3) External appearance inspection shall be conducted by using a single 20W fluorescent lamp or equivalent illumination.

(4) Visual inspection on the operation condition for cosmetic shall be conducted at the distance 30cm or more between the LCD panels and eyes of inspector. The viewing angle shall be 90 degree to the front surface of display panel.

(5) Ambient Illumination : 300~500 Lux for external appearance inspection.

(6) Ambient Illumination : 100~200 Lux for light on inspection.

### 5-2-2 Inspection Criteria

(1) Definition of dot defect induced from the panel inside

a) The definition of dot : The size of a defective dot over 1/2 of whole dot is regarded as one defective dot

b) Bright dot : Dots appear bright and unchanged in size in which LCD panel is displaying under black pattern.

c) Dark dot : Dots appear dark and unchanged in size in which LCD panel is displaying under pure red, green, blue pattern.

d) 2 dot adjacent = 1 pair = 2 dots

Picture :

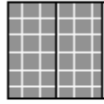

2 dot adjacent



2 dot adjacent (vertical)

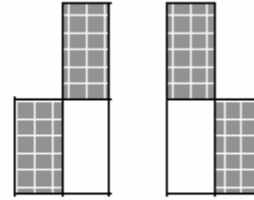

2 dot adjacent (slant)

(2) Display Inspection

NO.	Item		Acceptable Count	
1	Dot defect	Bright Dot	Random	$N \leq 2$
			2 dots adjacent	$N \leq 0$
		Dark Dot	Random	$N \leq 3$
			2 dots adjacent	$N \leq 1$
	Total bright and dark dot			$N \leq 4$
Functional failure (V-line/ H-line/Cross line etc.)			Not allowable	
	Mura	It's OK if mura is slight visible through 6% ND filter. (Judged by limit sample if it is necessary)		
2	Newton ring (touch panel)	Orbicular of interference fringes is not allowed in the optimum contrast within the active area under viewing angle.		

(3) Appearance inspection

NO.	Item	Standards
1	Panel Crack	Not allow. It is shown in Fig.1.
2	Broken CF Non -lead Side of TFT	The broken in the area of $W > 2\text{mm}$ is ignored, L is ignored. It is shown in Fig.2.
3	Broken Lead Side of TFT	FPC lead, electrical line or alignment mark can't be damaged. It is shown in Fig.3.
4	Broken Corner of TFT at Lead Side	FPC lead. electrical line or alignment mark can't be damaged. It is shown in Fig.4.
5	Burr of TFT / CF Edge	The distance of burr from the edge of TFT / CF, $W \leq 0.3\text{mm}$ . It is shown in Fig.5.
6	Foreign Black / White/Bright Spot	(1) $0.15 < D \leq 0.5 \text{ mm}$ , $N \leq 4$ ; (2) $D \leq 0.15\text{mm}$ , Ignore. It is shown in Fig.6.
7	Foreign Black / White/Bright Line	(1) $0.05 < W \leq 0.1 \text{ mm}$ , $0.3 < L \leq 2 \text{ mm}$ , $N \leq 4$ .
		(2) $W \leq 0.05\text{mm}$ and $L \leq 0.3\text{mm}$ Ignore. It is shown in Fig.7.
8	Color irregular	Not remarkable color irregular.



Fig 1.

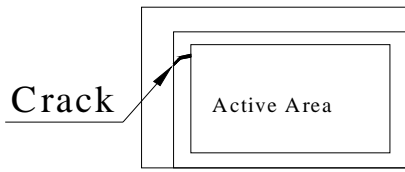

Fig 2.

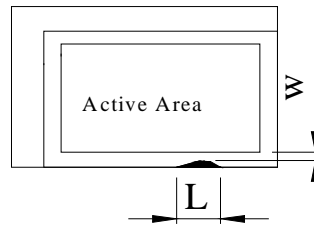

Fig 3.

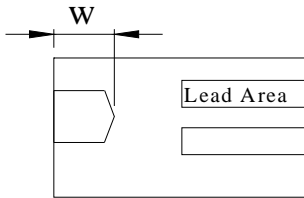

Fig 4.

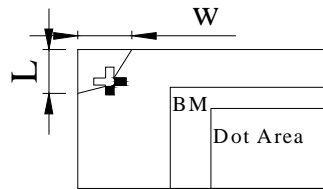

Fig 5.

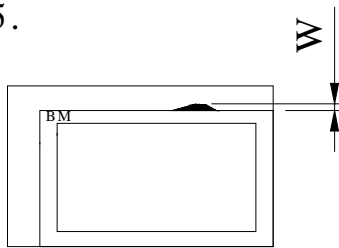
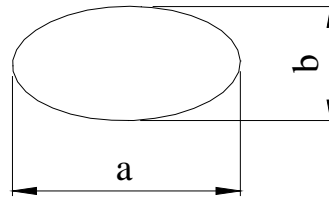

Fig 6.



$$D = (a + b) / 2$$

Fig 7.

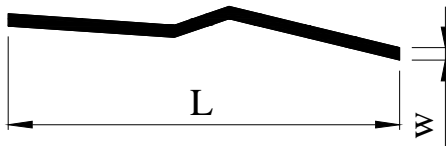
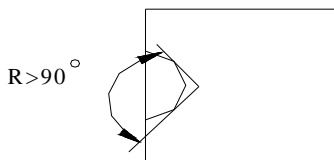

Fig8.



Notes

1.W:Width

2.Length

3.D:Average Diameter

4.N:Count

5.All the anhle of the broken must be larger than 90~.It is shown in Fig.8.(R>90~)

## NOTICE:

### • SAFETY

1. If the LCD panel breaks, be careful not to get the liquid crystal to touch your skin.
2. If the liquid crystal touches your skin or clothes, please wash it off immediately by using soap and water.

### • HANDLING

1. Avoid static electricity which can damage the CMOS LSI.
2. Do not remove the panel or frame from the module.
3. The polarizing plate of the display is very fragile. So, please handle it very carefully.
4. Do not wipe the polarizing plate with a dry cloth, as it may easily scratch the surface of plate.
5. Do not use ketonics solvent & Aromatic solvent. Use a soft cloth soaked with a cleaning naphtha solvent.

### • STORAGE

1. Store the panel or module in a dark place where the temperature is  $25\pm 5^{\circ}\text{C}$  and the humidity is below 65% RH.
2. Do not place the module near organics solvents or corrosive gases.
3. Do not crush, shake, or jolt the module.

### • TERMS OF WARRANT

1. Acceptance inspection period

The period is within one month after the arrival of contracted commodity at the buyer's factory site.

2. Applicable warrant period

The period is within twelve months since the date of shipping out under normal using and storage conditions.