

Silicon N-Channel MOSFET

Features

- 1.2A,600V, $R_{DS(on)}$ (Max8.5Ω)@ $V_{GS}=10V$
- Ultra-low Gate charge(Typical 9.1nC)
- Fast Switching Capability
- 100%Avalanche Tested
- Maximum Junction Temperature Range(150℃)

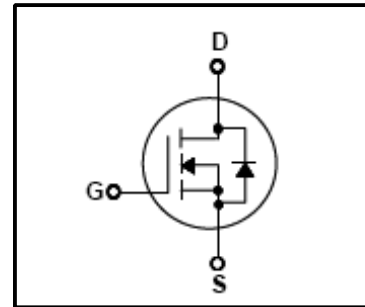

General Description

This Power MOSFET is produced using Winsemi's advanced planar stripe, VDMOS technology. This latest technology has been especially designed to minimize on-state resistance, have a high rugged avalanche characteristics. This device is specially well suited for high efficiency switch mode power supply, electronic Lamp ballasts based on half bridge and UPS.

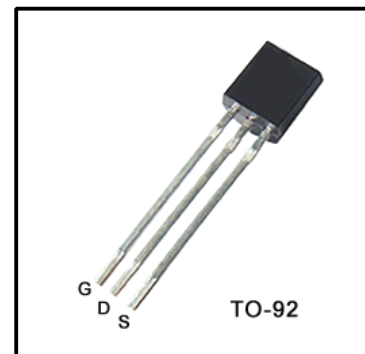

Absolute Maximum Ratings

Symbol	Parameter	Value	Units
V_{DSS}	Drain Source Voltage	600	V
I_D	Continuous Drain Current(@ $T_c=25^\circ C$)	1.2	A
	Continuous Drain Current(@ $T_c=100^\circ C$)	0.84	A
I_{DM}	Drain Current Pulsed (Note1)	5.0	A
V_{GS}	Gate to Source Voltage	±30	V
E_{AS}	Single Pulsed Avalanche Energy (Note2)	78	mJ
E_{AR}	Repetitive Avalanche Energy (Note1)	3.9	mJ
dv/dt	Peak Diode Recovery dv /dt (Note3)	5.5	V/ ns
P_D	Total Power Dissipation(@ $T_c=25^\circ C$)	4	W
	Derating Factor above 25℃	0.05	W/℃
T_J, T_{stg}	Junction and Storage Temperature	-55~150	℃
T_L	Channel Temperature	300	℃

Thermal Characteristics

Symbol	Parameter	Value			Units
		Min	Typ	Max	
R_{QJC}	Thermal Resistance , Junction -to -Case	-	-	31.2	℃/W
R_{QJA}	Thermal Resistance , Junction-to -Ambient	-	-	120	℃/W

Electrical Characteristics(Tc=25 °C)

Characteristics	Symbol	Test Condition	Min	Type	Max	Unit	
Gate leakage current	I _{GSS}	V _{GS} =±30V,V _{DS} =0V	-	-	±100	nA	
Gate-source breakdown voltage	V _{(BR)GSS}	I _G =±10 μA,V _{DS} =0V	±30	-	-	V	
Drain cut -off current	I _{DSS}	V _{DS} =600V,V _{GS} =0V	-	-	10	μA	
		V _{DS} =480V,TC=125 °C			100	μA	
Drain -source breakdown voltage	V _{(BR)DSS}	I _D =250 μA,V _{GS} =0V	600	-	-	V	
Breakdown voltage Temperature Coefficient	$\frac{\Delta BV_{DSS}}{\Delta T_J}$	I _D =1mA,Referenced to 25 °C	-	0.65	-	V/°C	
Gate threshold voltage	V _{GS(th)}	V _{DS} =V _{GS} ,I _D =250 μA	2.0	-	4.0	V	
Drain -source ON resistance	R _{DS(ON)}	V _{GS} =10V,I _D =0.6A	-	7.7	8.5	Ω	
Forward Transconductance	g _{fs}	V _{DS} =50V,I _D =0.6A	-	1.3	-	S	
Input capacitance	C _{iss}	V _{DS} =25V,	-	247	319	pF	
Reverse transfer capacitance	C _{rss}	V _{GS} =0V,	-	4.9	6.4		
Output capacitance	C _{oss}	f=1MHz	-	23	30		
Switching time	Turn-On Rise time	t _r	V _{DD} =300V, I _D =1.2A R _G =25Ω (Note4,5)	-	33	72	ns
	Turn-on delay time	T _{d(on)}		-	11	26	
	Turn-On Fall time	t _f		-	26	59	
	Turn-off delay time	T _{d(off)}		-	26	59	
Total gate charge(gate-source plus gate-drain)	Q _g	V _{DD} =480V, V _{GS} =10V,	-	9.1	12	nC	
Gate-source charge	Q _{gs}	I _D =1.2A	-	1.2	-		
Gate-drain("miller") Charge	Q _{gd}	(Note4,5)	-	4.5	-		

Source-Drain Ratings and Characteristics(Ta=25 °C)

Characteristics	Symbol	Test Condition	Min	Type	Max	Unit
Continuous drain reverse current	I _{DR}	-	-	-	1.2	A
Pulse drain reverse current	I _{DRP}	-	-	-	5.0	A
Forward voltage(diode)	V _{DSF}	I _{DR} =1.2A,V _{GS} =0V	-	-	1.4	V
Reverse recovery time	t _{rr}	I _{DR} =1.2A,V _{GS} =0V,	-	163	-	ns
Reverse recovery charge	Q _{rr}	dI _{DR} / dt =100 A / μs	-	0.85	-	μC

Note 1.Repeativity rating :pulse width limited by junction temperature

2.L=92mH I_{AS}=1.2A,V_{DD}=50V,R_G=25Ω,Starting T_J=25 °C

3.I_{SD}≤1.2A,di/dt≤200A/us,V_{DD}<BV_{DSS},STARTING T_J=25 °C

4.Pulse Test:Pulse Width≤300us,Duty Cycle≤2%

5. Essentially independent of operating temperature.

This transistor is an electrostatic sensitive device

Please handle with caution



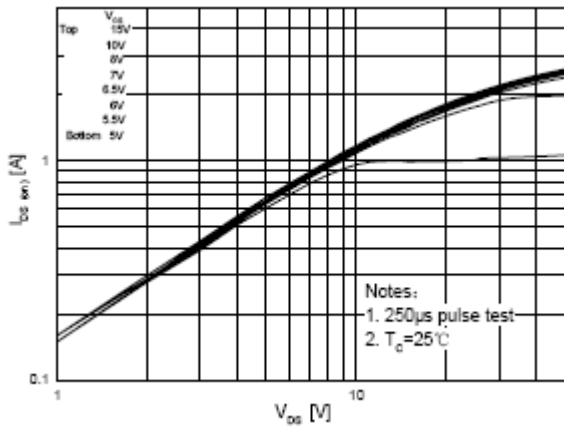

Fig.1 On State Characteristics

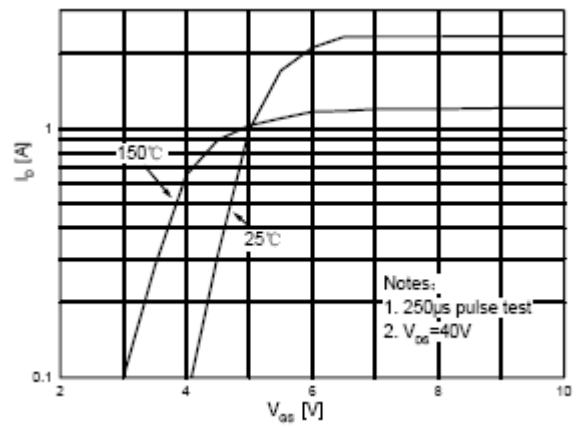

Fig.2 Transfer Characteristics

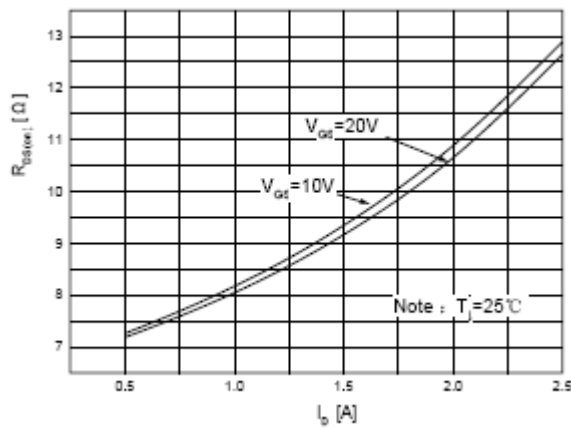

Fig.3 On-Resistance Variation vs Drain current and gate voltage

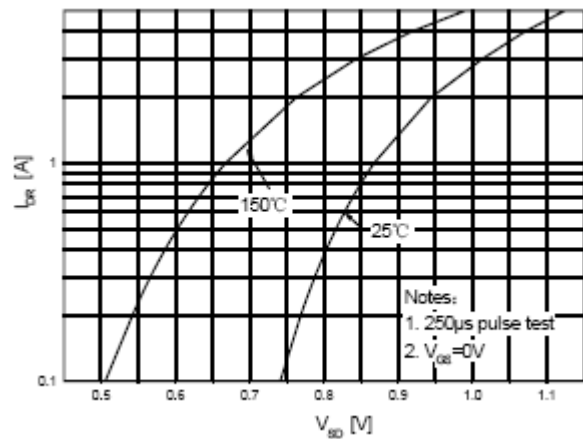

Fig.4 Body diode Forward voltage variation vs source current and temperature

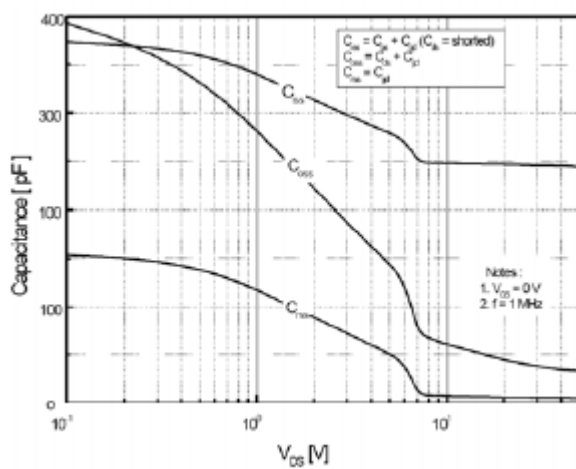

Fig.5 Capacitance characteristics

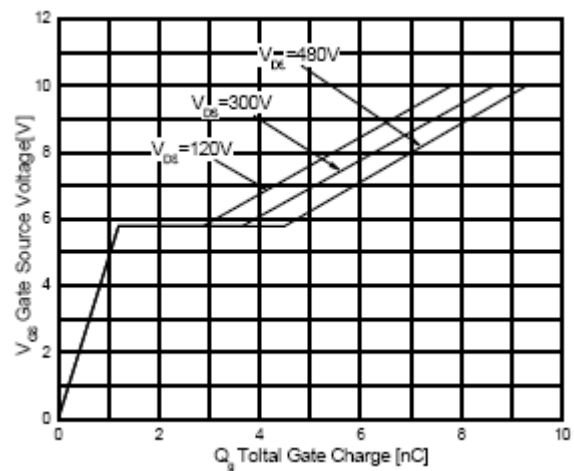

Fig.6 Gate Charge Characteristics

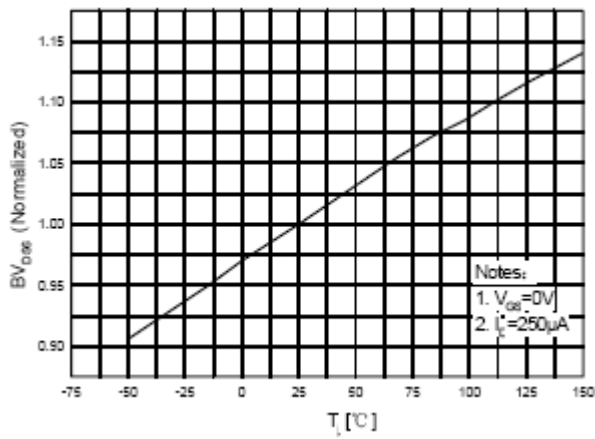

Fig.7 Breakdown voltage variation vs temperature

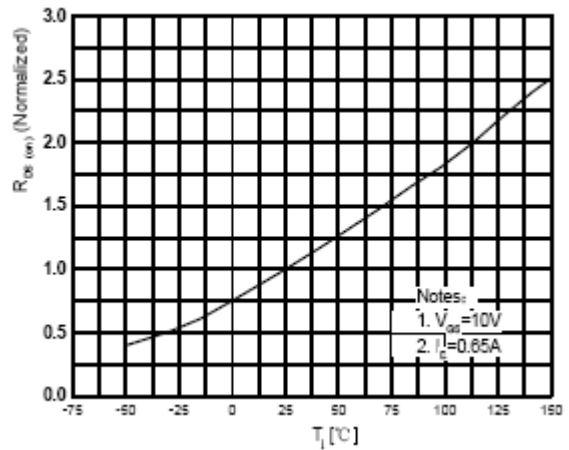

Fig.8 On-Resistance variation vs temperature

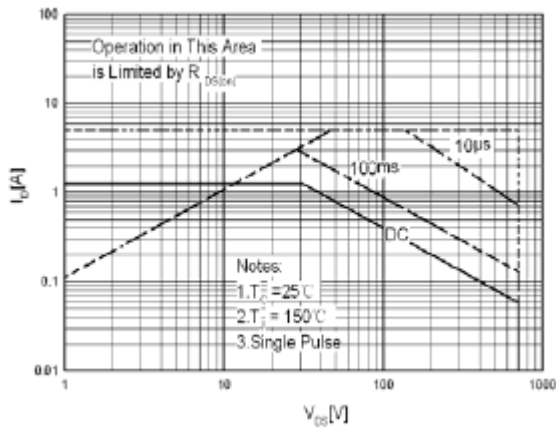

Fig.7 Maximum Safe Operation Area

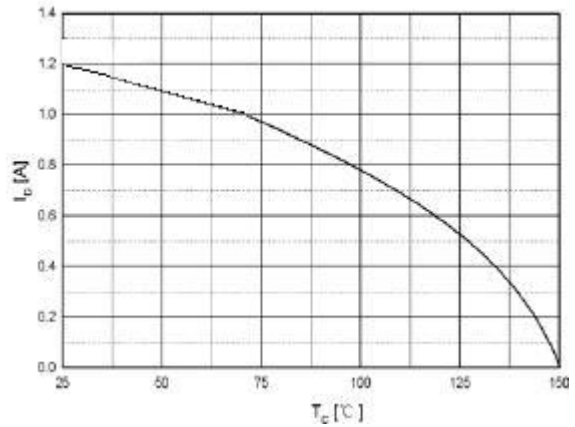

Fig.8 Maximum Drain Current vs Case temperature

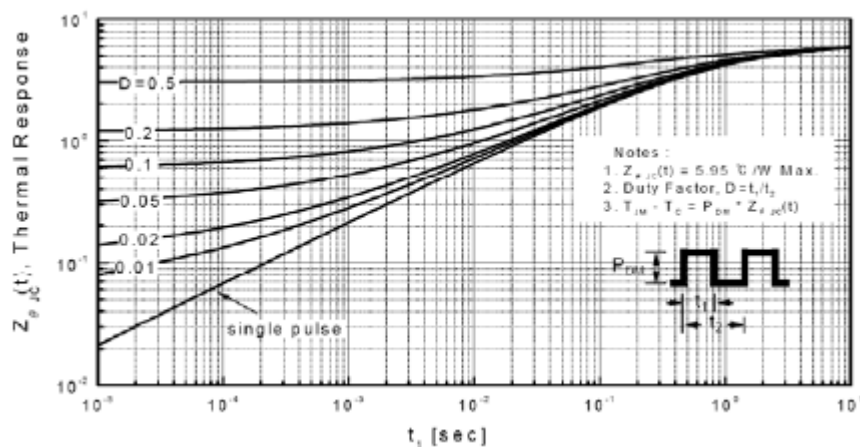

Fig.9 Transient thermal Response Curve

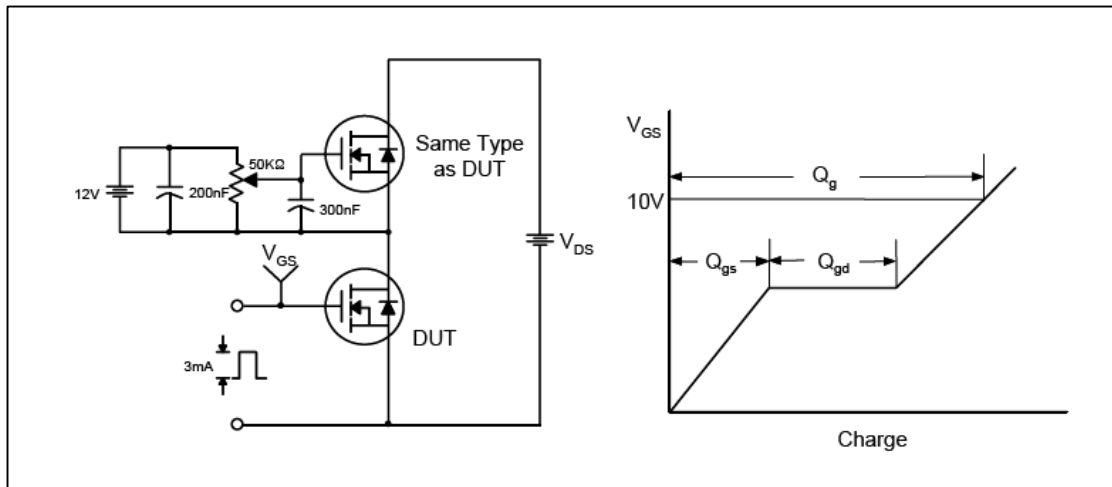

Fig.10 Gate Test circuit & Waveform

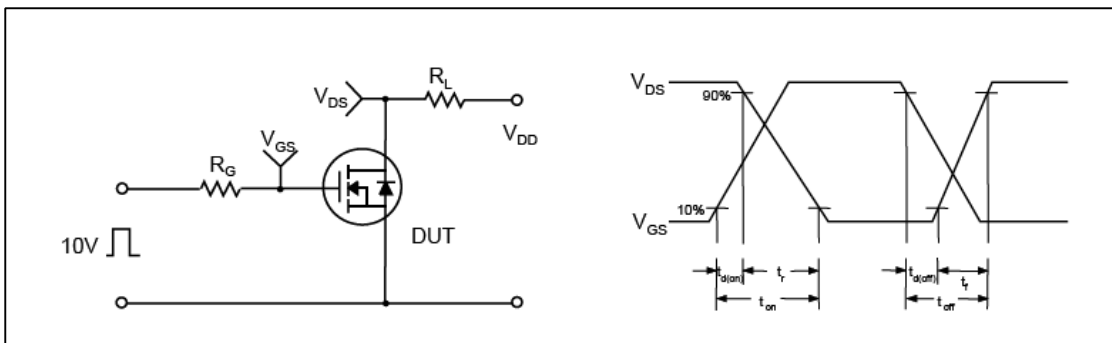

Fig.11 Resistive Switching Test Circuit & Waveform

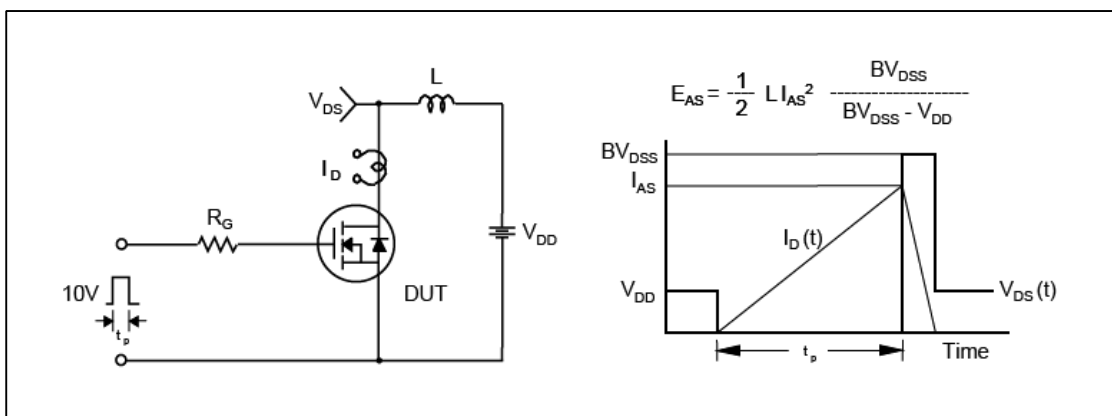

Fig.12 Unclamped Inductive Switching Test Circuit & Waveform

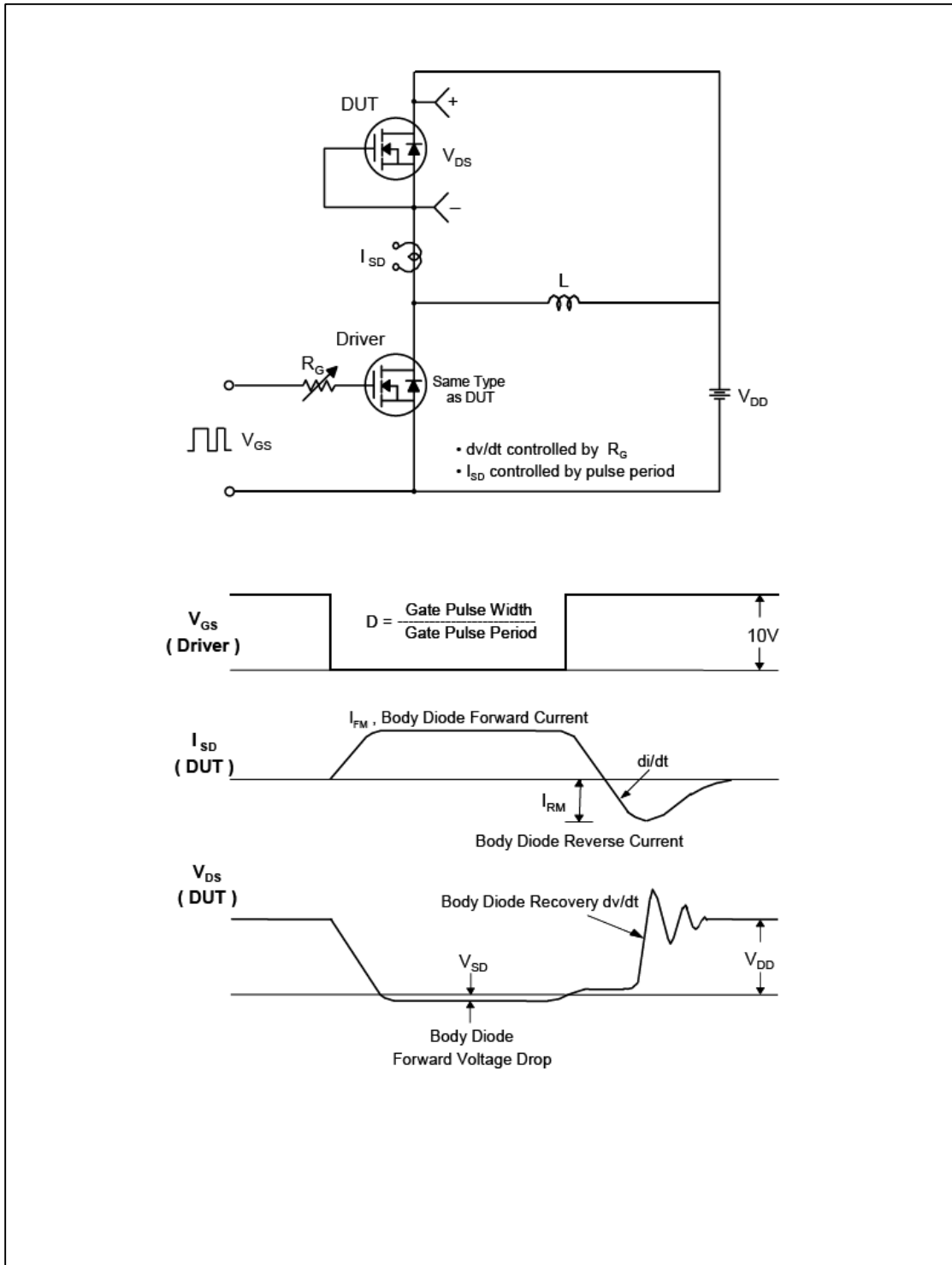

Fig.13 Peak Diode Recovery dv/dt Test Circuit & Waveform

TO92 Package Dimension

Unit:mm

