

Silicon N-Channel MOSFET

Features

- 0.5A,600V,RDS(on)(Max15.0Ω)@VGS=10V
- Ultra-low Gate Charge(Typical 6.1nC)
- Fast Switching Capability
- 100%Avalanche Tested
- Maximum Junction Temperature Range(150°C)

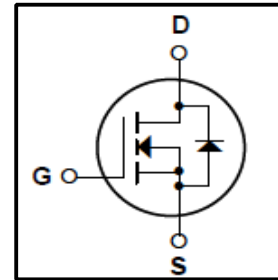

General Description

This Power MOSFET is produced using Winsemi's advanced planar stripe, VDMOS technology. This latest technology has been especially designed to minimize on-state resistance, have a high rugged avalanche characteristics. This devices is specially well suited for high efficiency switch mode power supply. electronic Lamp ballasts based on half bridge and UPS.

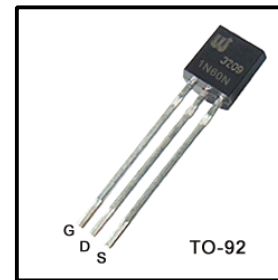

Absolute Maximum Ratings

Symbol	Parameter	Value	Units
V _{DSS}	Drain Source Voltage	600	V
I _D	Continuous Drain Current(@Tc=25°C)	0.5	A
	Continuous Drain Current(@Tc=100°C)	0.31	A
I _{DM}	Drain Current Pulsed (Note1)	2.0	A
V _{GS}	Gate to Source Voltage	±30	V
E _{AS}	Single Pulsed Avalanche Energy (Note 2)	47	mJ
E _{AR}	Repetitive Avalanche Energy (Note 1)	3.0	mJ
dv/dt	Peak Diode Recovery dv/dt (Note 3)	4.2	V/ns
P _D	Total Power Dissipation(@Tc=25°C)	2.0	W
	Derating Factor above 25°C	0.025	W/°C
T _J , T _{stg}	Junction and Storage Temperature	-55~150	°C
T _L	Channel Temperature	300	°C

Thermal Characteristics

Symbol	Parameter	Value			Units
		Min	Typ	Max	
R _{QJC}	Thermal Resistance, Junction-to-Case	-	-	62.5	°C/W
R _{QJA}	Thermal Resistance, Junction-to-Ambient	-	-	120	°C/W

Electrical Characteristics (Tc = 25°C)

Characteristics	Symbol	Test Condition	Min	Type	Max	Unit	
Gate leakage current	I _{GSS}	V _{GS} = ±30 V, V _{DS} = 0 V	-	-	±100	nA	
Gate-source breakdown voltage	V _{(BR)GSS}	I _G = ±10 μA, V _{DS} = 0 V	±30	-	-	V	
Drain cut-off current	I _{DSS}	V _{DS} = 600 V, V _{GS} = 0 V	-	-	10	μA	
		V _{DS} = 480 V, T _C = 125°C	-	-	100	μA	
Drain-source breakdown voltage	V _{(BR)DSS}	I _D = 250 μA, V _{GS} = 0 V	600	-	-	V	
Break Voltage Temperature Coefficient	ΔBV _{DSS} /ΔT _J	I _D =250μA, Referenced to 25°C	-	0.6	-	V/°C	
Gate threshold voltage	V _{GS(th)}	V _{DS} = 10 V, I _D = 250 μA	2	-	4	V	
Drain-source ON resistance	R _{DS(ON)}	V _{GS} = 10 V, I _D = 0.5A	-	11	15	Ω	
Forward Transconductance	g _{fs}	V _{DS} = 40 V, I _D = 0.5A	-	0.8	-	S	
Input capacitance	C _{iss}	V _{DS} = 25 V,	-	178	221	pF	
Reverse transfer capacitance	C _{rss}	V _{GS} = 0 V,	-	4	5		
Output capacitance	C _{oss}	f = 1 MHz	-	19	27		
Switching time	Turn-on delay time	t _{d(on)}	V _{DD} = 300 V, I _D = 1A R _G = 25Ω (Note 4,5)	-	16	46	ns
	Rise time	t _r		-	45	104	
	Turn-off delay time	t _{d(off)}		-	25	61	
	Fall time	t _f		-	36	81	
Total gate charge (gate-source plus gate-drain)	Q _g	V _{DD} = 480 V, V _{GS} = 10 V, I _D = 1 A (Note 4,5)	-	6.1	7.2	nC	
Gate-source charge	Q _{gs}		-	1.0	-		
Gate-drain ("miller") Charge	Q _{gd}		-	3.0	-		

Source-Drain Ratings and Characteristics (Ta = 25°C)

Characteristics	Symbol	Test Condition	Min	Type	Max	Unit
Continuous drain reverse current	I _{DR}	-	-	-	1.0	A
Pulse drain reverse current	I _{DRP}	-	-	-	4.0	A
Forward voltage (diode)	V _{DSF}	I _{DR} = 1A, V _{GS} = 0 V	-	-	1.5	V
Reverse recovery time	t _{rr}	I _{DR} = 1A, V _{GS} = 0 V,	-	185	-	ns
Reverse recovery charge	Q _{rr}	dI _{DR} / dt = 100 A / μs	-	0.51	-	μC

Note 1. Repeatability rating : pulse width limited by junction temperature

2. L=59mH, I_{AS}=1A, V_{DD}=50V, R_G=25Ω, Starting T_J=25°C

3. I_{SD}≤1A, di/dt≤200A/μs, V_{DD}<BV_{DSS}, STARTING T_J=25°C

4. Pulse Test: Pulse Width≤300μs, Duty Cycle≤2%

5. Essentially independent of operating temperature.

This transistor is an electrostatic sensitive device

Please handle with caution

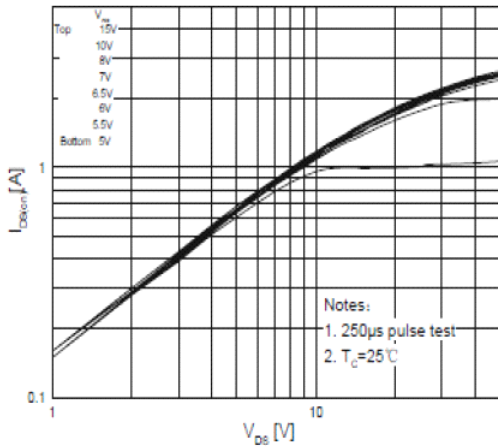

Fig. 1 On-State Characteristics

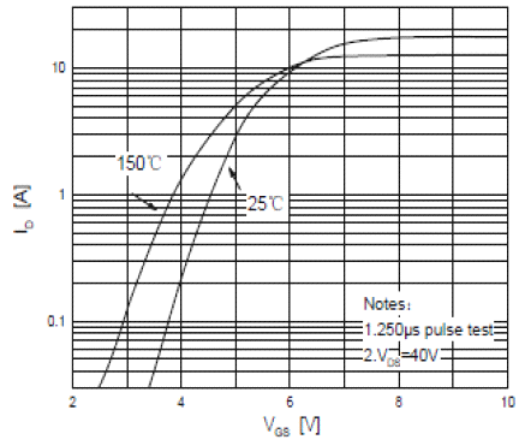

Fig. 2 Transfer Current Characteristics

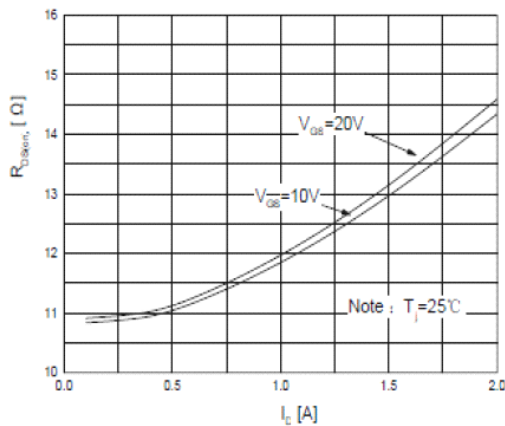

Fig. 3 On-Resistance Variation vs Drain Current

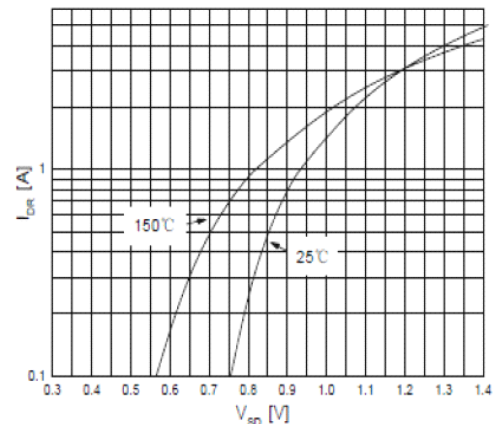

Figure 4. Body Diode Forward Voltage Variation with Source Current and Temperature

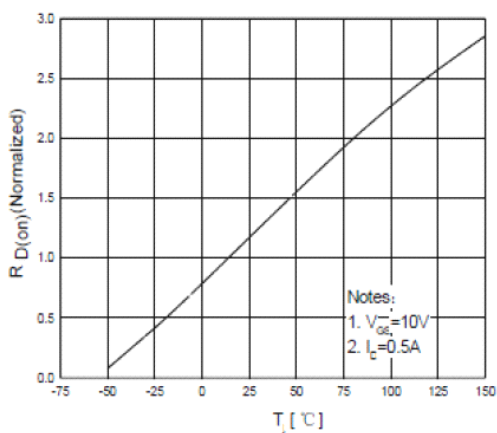

Fig. 5 On-Resistance Variation vs Junction Temperature

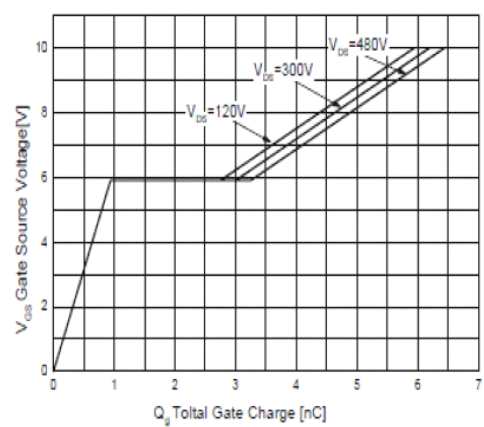

Fig. 6 Gate Charge Characteristics

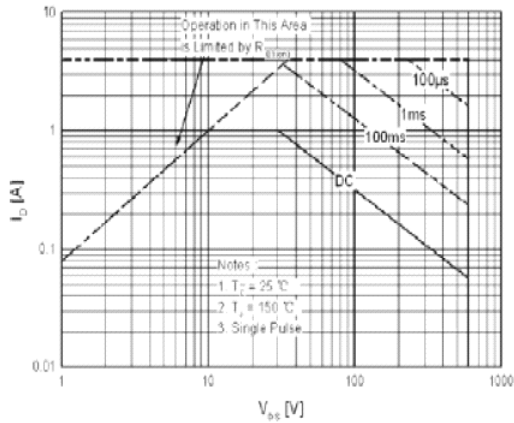

Fig.7 Maximum Safe Operation Area

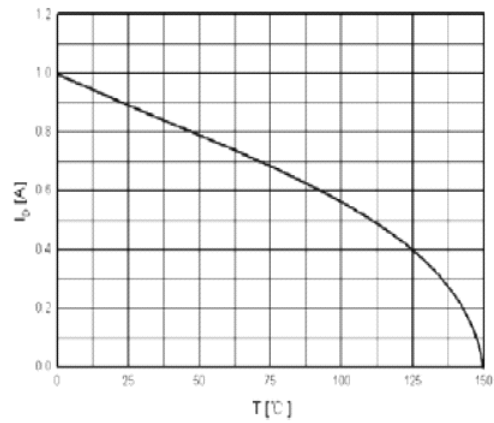

Fig.8 Maximum Drain Current vs Case Temperature

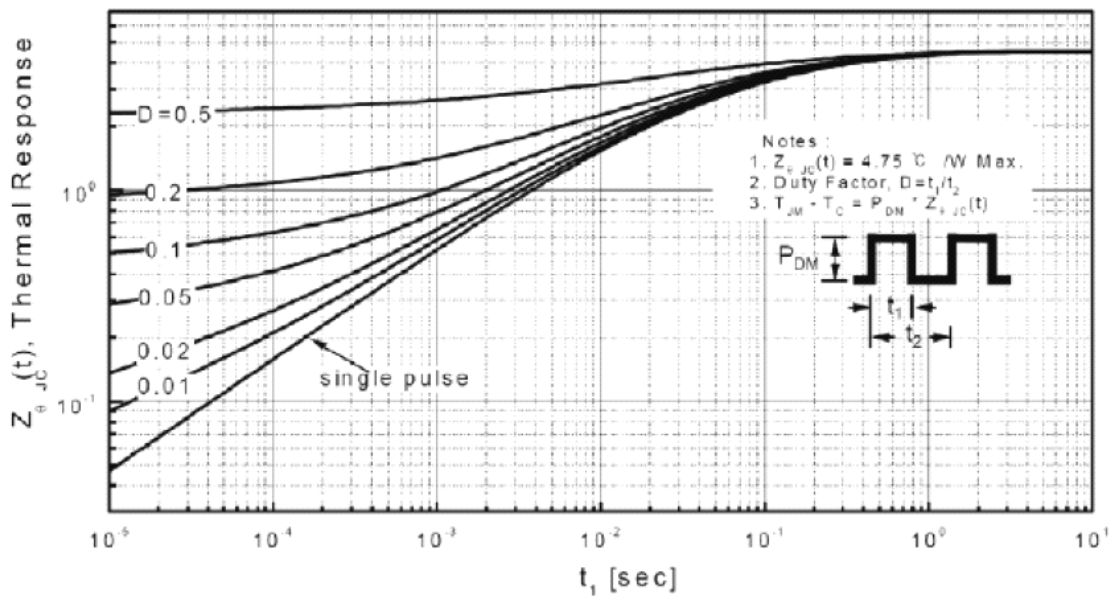

Fig.9 Transient Thermal Response Curve

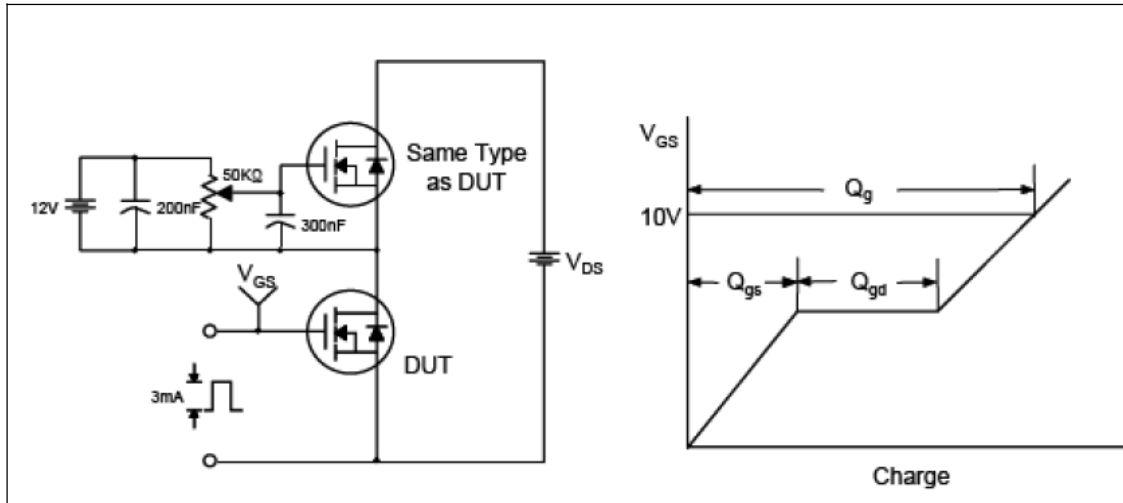

Fig.10 Gate Test Circuit & Waveform

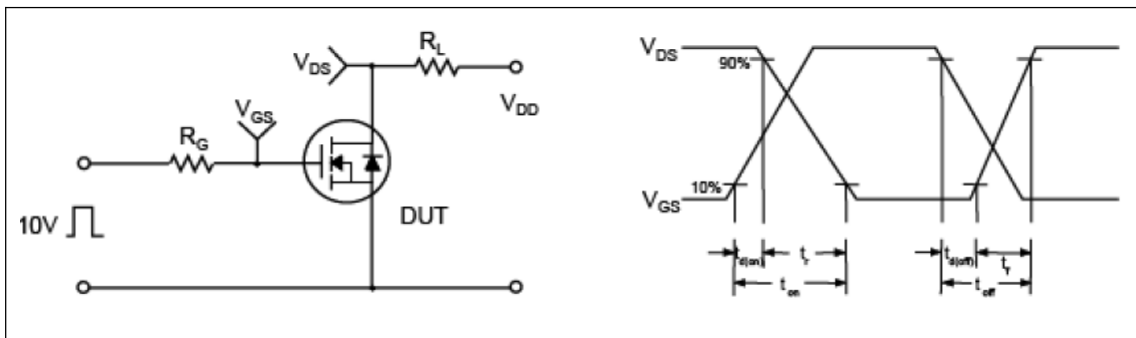

Fig.11 Resistive Switching Test Circuit & Waveform

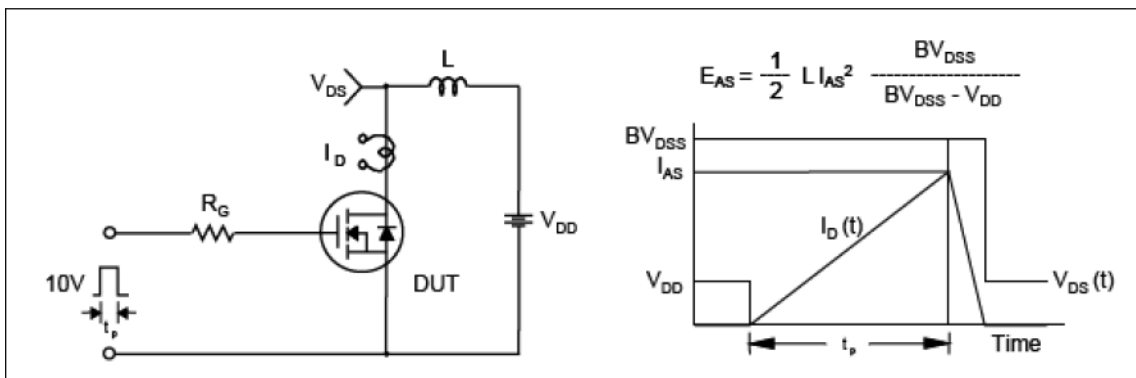

Fig.12 Unclamped Inductive Switching Test Circuit & Waveform

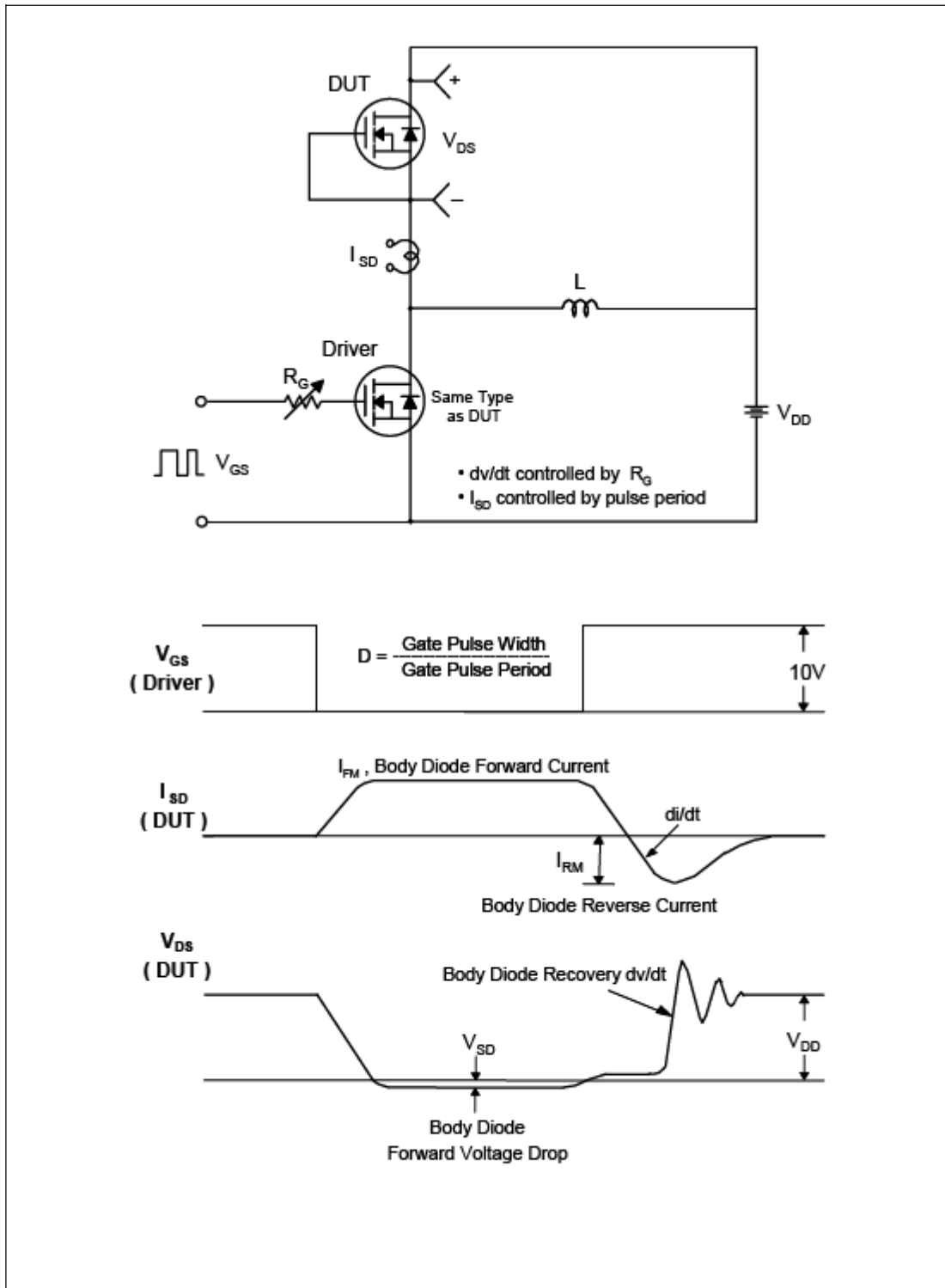

Fig.13 Peak Diode Recovery dv/dt Test Circuit & Waveform

TO92 Package Dimension

Unit: mm

