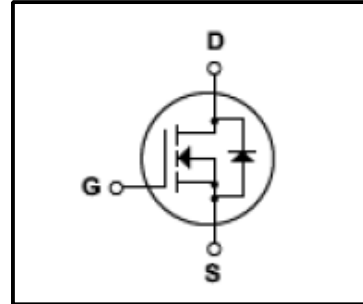
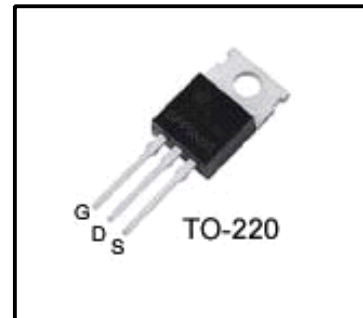

Silicon N-Channel MOSFET
Features

- 18A,200V, $R_{DS(on)}$ (Max 0.18 Ω)@ $V_{GS}=10V$
- Ultra-low Gate Charge(Typical 40nC)
- Fast Switching Capability
- 100%Avalanche Tested
- Maximum Junction Temperature Range(150 $^{\circ}C$)

General Description

This Power MOSFET is produced using Winsemi's advanced planar stripe, DMOS technology. This latest technology has been especially designed to minimize on-state resistance, have a high rugged avalanche characteristics. This device is specially well suited for low voltage applications such as automotive, high efficiency switching for DC/DC converters, and DC motor control.

Absolute Maximum Ratings

| Symbol | Parameter | Value | Units |
|----------------|---|----------|----------------|
| V_{DSS} | Drain Source Voltage | 200 | V |
| I_D | Continuous Drain Current(@ $T_c=25^{\circ}C$) | 18 | A |
| | Continuous Drain Current(@ $T_c=100^{\circ}C$) | 12 | A |
| I_{DM} | Drain Current Pulsed (Note1) | 72 | A |
| V_{GS} | Gate to Source Voltage | ± 30 | V |
| E_{AS} | Single Pulsed Avalanche Energy (Note2) | 580 | mJ |
| E_{AR} | Repetitive Avalanche Energy (Note1) | 13 | mJ |
| dv/dt | Peak Diode Recovery dv /dt (Note3) | 5 | V/ ns |
| P_D | Total Power Dissipation(@ $T_c=25^{\circ}C$) | 140 | W |
| | Derating Factor above 25 $^{\circ}C$ | 0.78 | W/ $^{\circ}C$ |
| T_J, T_{stg} | Junction and Storage Temperature | -55~150 | $^{\circ}C$ |
| T_L | Channel Temperature | 300 | $^{\circ}C$ |

Thermal Characteristics

| Symbol | Parameter | Value | | | Units |
|-----------|---|-------|-----|------|---------------|
| | | Min | Typ | Max | |
| R_{QJC} | Thermal Resistance , Junction -to -Case | - | - | 0.89 | $^{\circ}C/W$ |
| R_{ACS} | Thermal Resistance, Case- to -Sink | - | 0.5 | - | $^{\circ}C/W$ |
| R_{QJA} | Thermal Resistance , Junction-to -Ambient | - | - | 62.5 | $^{\circ}C/W$ |

Electrical Characteristics(Tc=25°C)

| Characteristics | Symbol | Test Condition | Min | Type | Max | Unit | |
|--|----------------------|---|--------------------------------|------|------|------|----|
| Gate leakage current | I _{GSS} | V _{GS} =±30V,V _{DS} =0V | - | - | ±100 | nA | |
| Gate-source breakdown voltage | V _{(BR)GSS} | I _G =±10 μA,V _{DS} =0V | ±30 | - | - | V | |
| Drain cut -off current | I _{DSS} | V _{DS} =200V,V _{GS} =0V | - | - | 1 | μA | |
| Drain -source breakdown voltage | V _{(BR)DSS} | I _D =250 μA,V _{GS} =0V | 200 | - | - | V | |
| Gate threshold voltage | V _{GS(th)} | V _{DS} =10V,I _D =250 μA | 2 | - | 4 | V | |
| Drain -source ON resistance | R _{DS(ON)} | V _{GS} =10V,I _D =11A | - | - | 0.18 | Ω | |
| Forward Transconductance | g _{fs} | V _{DS} =50V,I _D =11A | 6.7 | - | - | S | |
| Input capacitance | C _{iss} | V _{DS} =25V, | - | - | 1300 | pF | |
| Reverse transfer capacitance | C _{rss} | V _{GS} =0V, | - | - | 430 | | |
| Output capacitance | C _{oss} | f=1MHz | - | - | 130 | | |
| Switching time | Rise time | t _r | V _{DD} =100V, | - | 14 | - | ns |
| | Turn-on time | t _{on} | I _D =18A, | - | 51 | - | |
| | Fall time | t _f | R _G =9.1Ω, | - | 45 | - | |
| | Turn-off time | t _{off} | R _D =5.4Ω (Note4,5) | - | 36 | - | |
| Total gate charge(gate-source plus gate-drain) | Q _g | V _{DD} =160V, V _{GS} =10V, | - | 40 | 70 | nC | |
| Gate-source charge | Q _{gs} | I _D =18A | - | - | 13 | | |
| Gate-drain("miller") Charge | Q _{gd} | (Note4,5) | - | - | 39 | | |

Source-Drain Ratings and Characteristics(Ta=25°C)

| Characteristics | Symbol | Test Condition | Min | Type | Max | Unit |
|----------------------------------|------------------|---|-----|------|-----|------|
| Continuous drain reverse current | I _{DR} | - | - | - | 18 | A |
| Pulse drain reverse current | I _{DRP} | - | - | - | 72 | A |
| Forward voltage(diode) | V _{DSF} | I _{DR} =18A,V _{GS} =0V | - | 1.4 | 2.0 | V |
| Reverse recovery time | t _{rr} | I _{DR} =18A,V _{GS} =0V, | - | 300 | 610 | ns |
| Reverse recovery charge | Q _{rr} | dI _{DR} / dt ≤ 100 A / μs | - | 3.4 | 7.1 | μC |

Note 1.Repeativity rating :pulse width limited by junction temperature

2.L=18.5mH I_{AS}=18A,V_{DD}=50V,R_G=0Ω ,Starting T_J=25°C

3.I_{SD}≤18A,di/dt≤300A/us,V_{DD}<BV_{DSS},STARTING T_J=25°C

4.Pulse Test:Pulse Width≤300us,Duty Cycle≤2%

5. Essentially independent of operating temperature.

This transistor is an electrostatic sensitive device

Please handle with caution

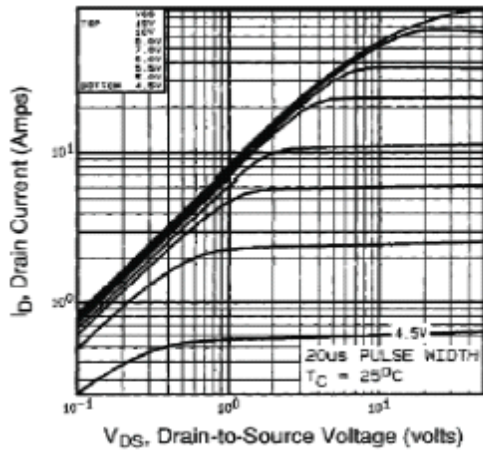

Fig.1 On-State Characteristics

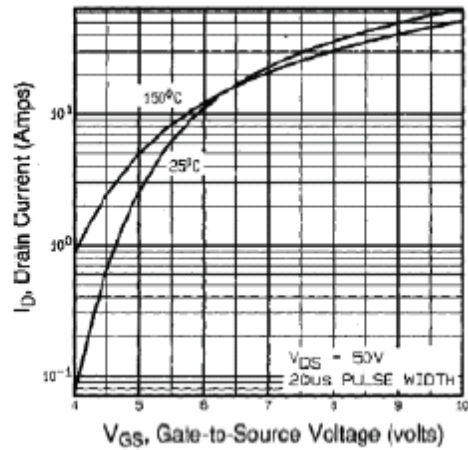

Fig.2 Transfer characteristics

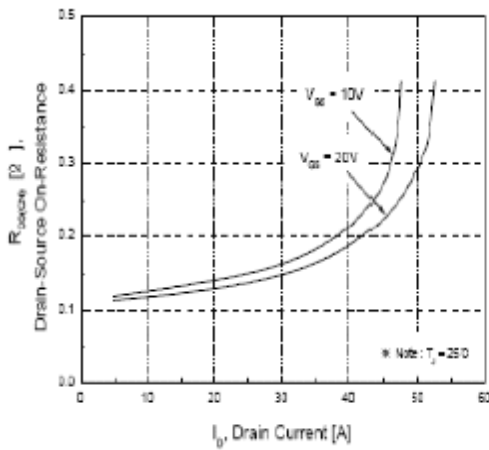

Fig.3 On-Resistance Variation vs Drain Current

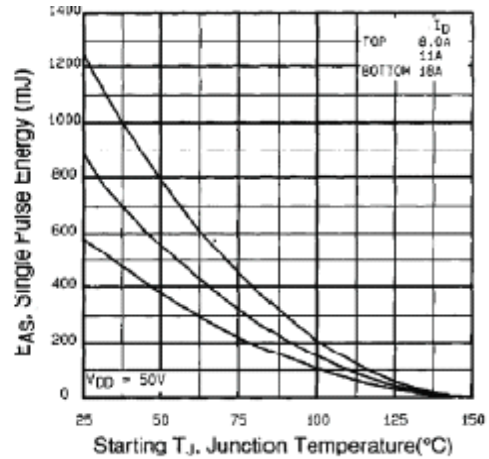

Fig.4 Maximum Avalanche Energy vs On-State Current

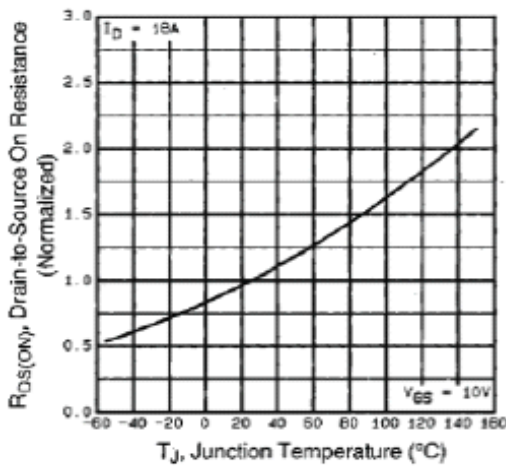

Fig.5 On-Resistance Variation vs Junction Temperature

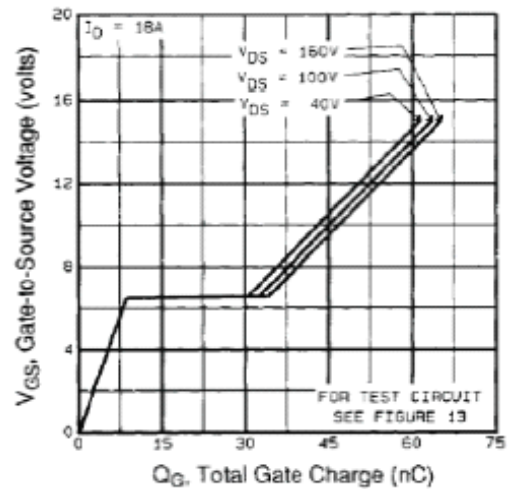

Fig.6 Gate Charge Characteristics

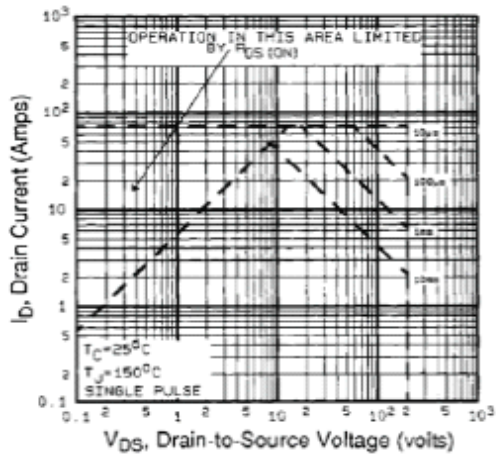

Fig.7 Maximum Safe Operation Area

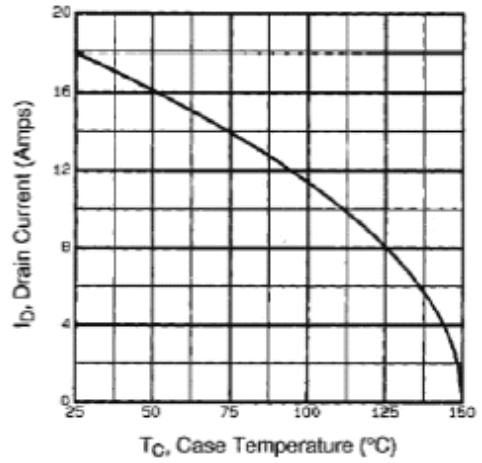

Fig.8 Maximum Drain Current vs Case Temperature

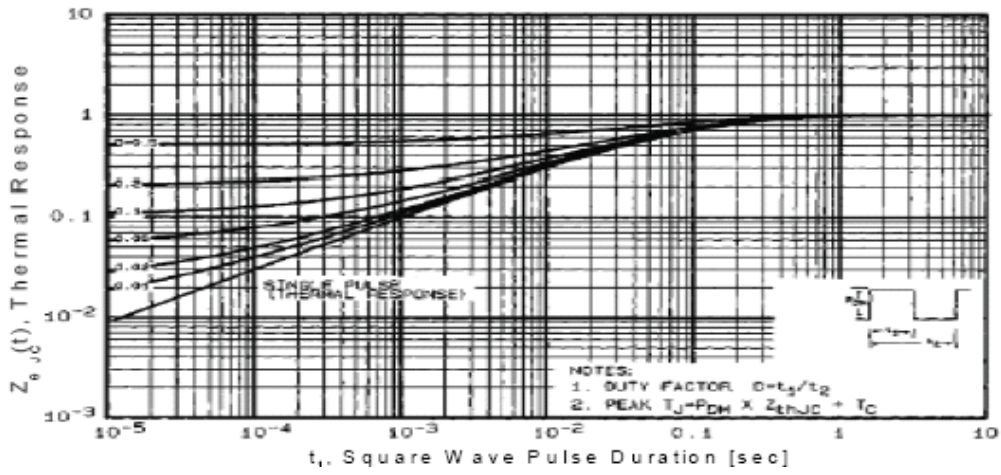

Fig.9 Transient Thermal Response curve

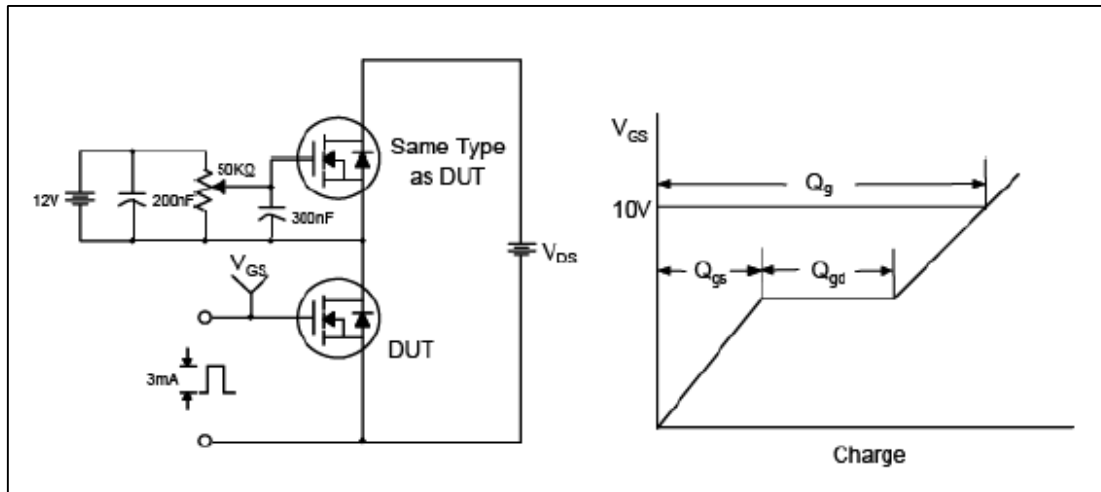

Fig.10 Gate Test circuit & Waveform

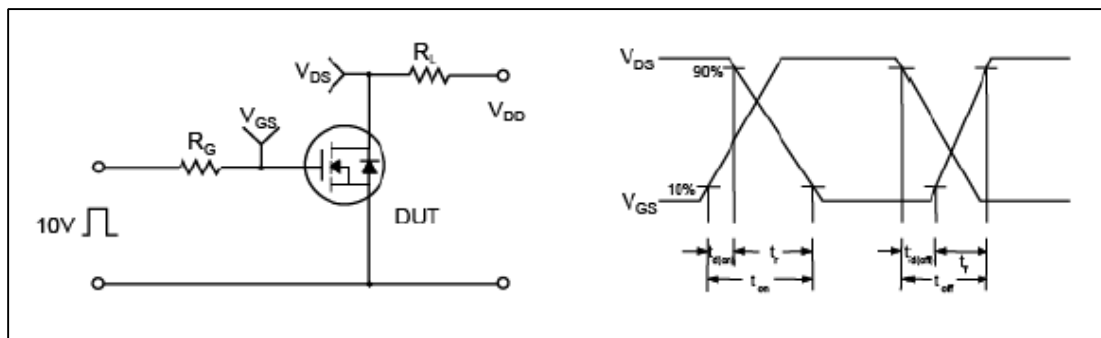

Fig.11 Resistive Switching Test Circuit & Waveform

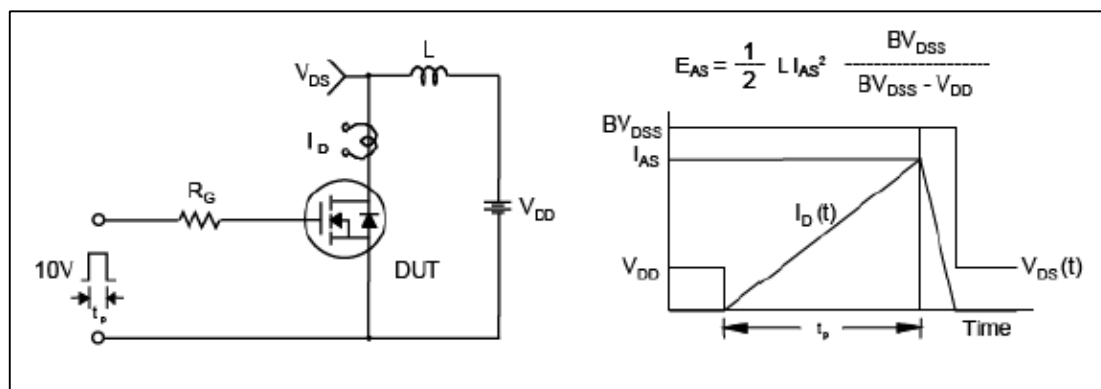

Fig.12 Uncamped Inductive Switching Test Circuit & Waveform

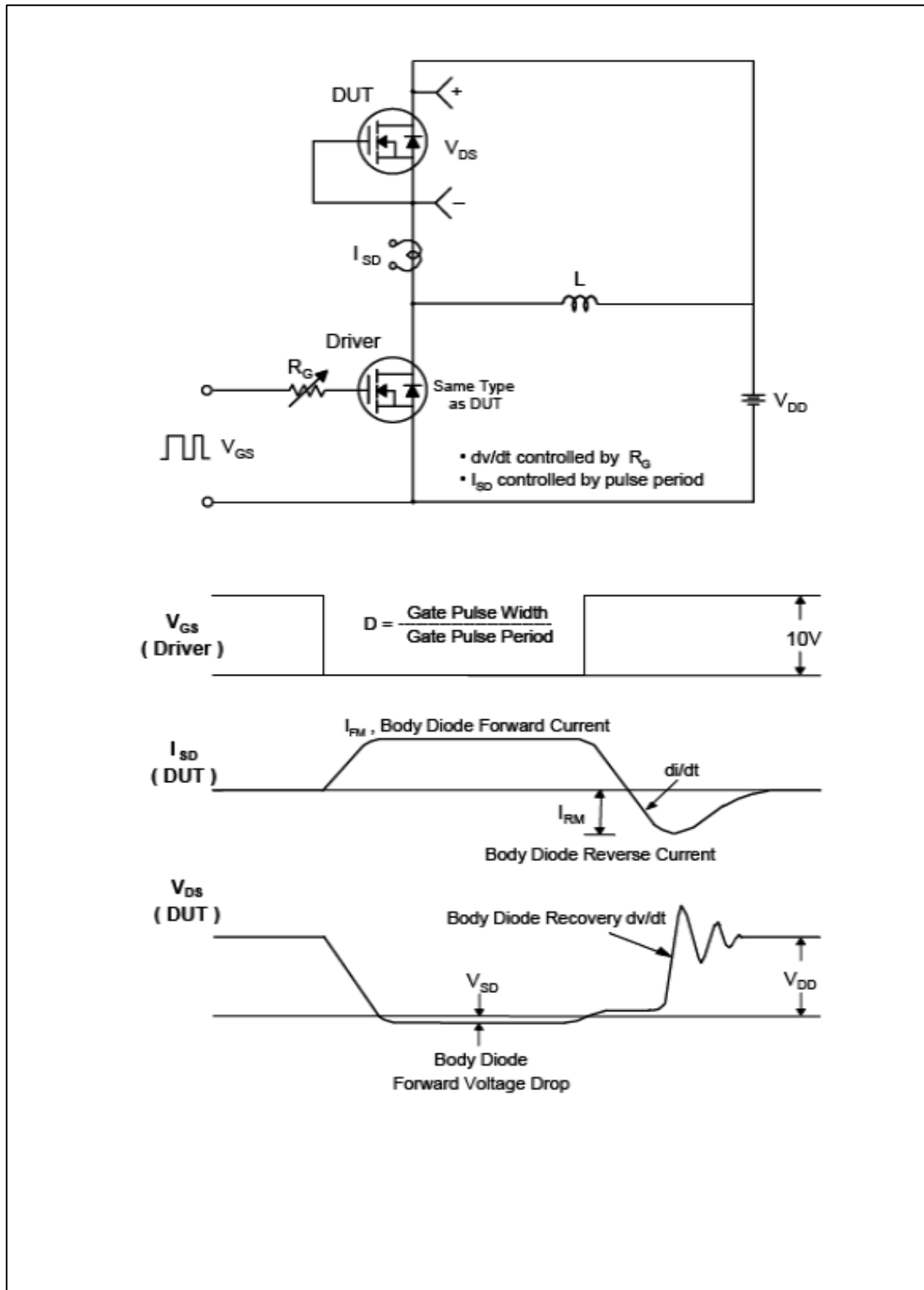

Fig.13 Peak Diode Recovery dv/dt Test Circuit & Waveform

TO-220 Package Dimension

