



a module solution provider

WG2250 WLAN Module

MTK IEEE 802.11b/g solution

WG2250 Specification

Revision 0.2

Revision

Revision	Date	Description
R 0.1	2009/03/02	New release for Brief
R 0.2	2009/05/21	Adding Chapter 4, 5 & 6

Contents

1. OVERVIEW	2
2. BLOCK DIAGRAM	3
3. MODULE SPECIFICATION	4
3.1. General Specification.....	4
3.2. Absolute Maximum Ratings	5
3.3. RF Characteristic	5
4. PACKAGE INFORMATION	7
4.1. Signal Layout (Top View)	7
4.2. Pin Assignment	7
4.3. Module Marking	10
5. MECHANICAL CHARACTERISTICS	11
5.1. Module Dimension	11
5.2. Recommended Footprint	12
6. SMT & BAKING RECOMMENDATION	13
6.1. Baking Recommendation	13
6.2. SMT Recommendation	13

1. OVERVIEW

WG2250, an 802.11b/g WLAN module with ultra small size, is the best solution for cell phones and other handheld devices to have IEEE802.11b and 802.11g functionality. This module is the perfect way to offer high-speed, worldwide wireless connectivity in handheld devices of all kinds.

WG2250 module supports SDIO, SPI and E-HPI interfaces makes it easy to be implemented into various platforms with great WiFi performance.

Features

- **Host interface**
 - SDIO/ eHPI

- **MAC**
 - Hardware MAC state machine
 - Support ad-hoc and infrastructure modes
 - Support 32 multicast address filters
 - Programmable TX/RX FIFO size
 - 802.11H packet format translation
 - 802.11 auto rate control
 - Support BT co-existence
 - Up to 12 pair-wise keyed peers
 - 802.11 a/b/g/e/i/h/k/w compatible
 - TX/RX on-the-fly encryption/decryption
 - 64/128-bit Wired Equivalent Privacy (WEP), Encryption Standard (AES-CCMP)
 - Support low power consumption sleep mode via 32KHz clock
 - Support 802.11 IBSS and infrastructure power save
 - Support hardware scan
 - Background scan for specific SSID networks
 - Support 802.11e optional U-APSD, Admission Control Procedure, and DLS
 - TCP/UDP/IP checksum generation/verification
 - TX MPDU lifetime record
 - Wakeup by specific packet (pattern search)
 - Support CCX5

- Support internal/external thermo-sensor to resist temperature change
- **Baseband**
 - Support Orthogonal Frequency Division Multiplexing (OFDM), Complementary Code Keying (CCK) and Direct Sequence Spread Spectrum (DSSS) to provide a variety of data rates

2. BLOCK DIAGRAM

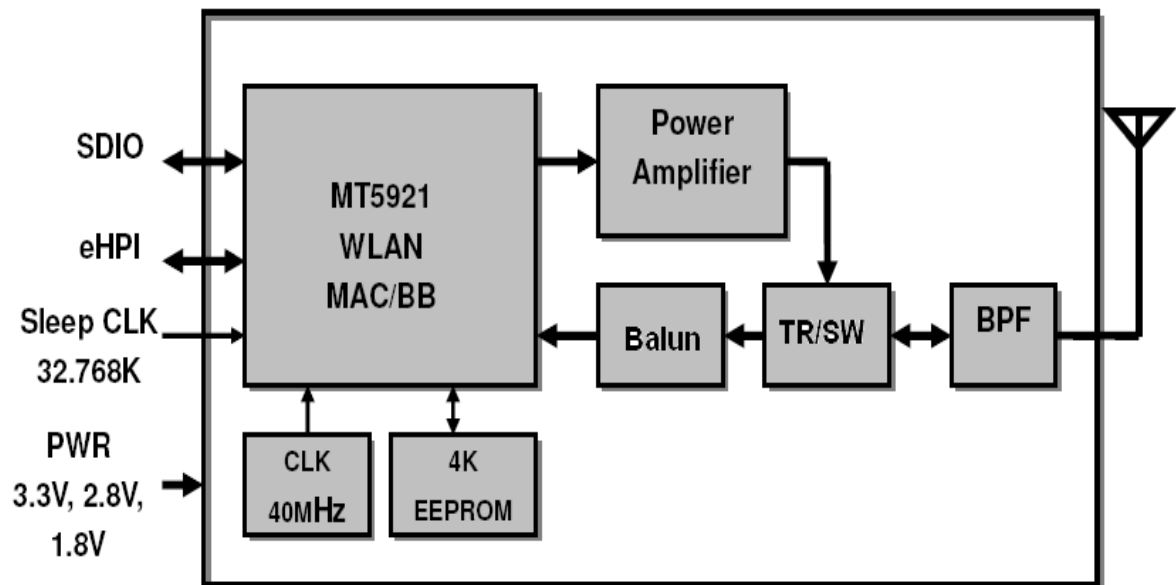

3. MODULE SPECIFICATION

3.1. General Specification

Item		Specification
Module Type	Pin outs	48 pins LGA Type (GND Pads: pin51 ~ 57)
	Dimension	9.0 x 9.0 x 1.6mm (with shielding case)
Chipset	MAC/BB	MTK MT5921
Interface		SDIO, E-HPI
Antenna Port		1 Pin out connected to external Antenna
Standard		IEEE 802.11b/g
Protocol		CSMA/CA with ACK
Frequency (MHz)		2412, 2417, 2422, 2427, 2432, 2437, 2442, 2447, 2452, 2457, 2462, 2467, 2472, 2484
Modulation		DBPSK (1Mbps), DQPSK(2Mbps), CCK (5.5, 11Mbps), OFDM (6, 9, 12, 24,36,48,54Mbps)
Channel		1~11 Channels for USA 1~13 Channels for Europe 1~14 Channels for Japan
Spurious Emission		FCC Part 15 Class B/C, 15.247, 15.249 and 15.109 for USA ETSI 300 328-2, 301 489-1/-17, EN60950, CE Marker for Europe
Data Rate		IEEE802.11 data rates of 1 and 2 Mbps IEEE802.11b data rates of 5.5 and 11 Mbps IEEE802.11g data rates of 6, 9, 12, 18, 24, 36, 48, 54 Mbps
WEP		Support 64/128/152 bit WEP Encryption
WPA		(WPA+802.1X) Support
Operating Temperature		-10°C ~ 65°C
Storage Temperature		-20°C ~ 85°C

3.2. Absolute Maximum Ratings

Over operating free-air temperature range

Characteristics		Min.	Typ.	Max.	Unit
DVDD33	Digital I/O Power Supply	2.52	2.8~3.3	3.63	V
DVDD28	Digital I/O Power Supply	2.52	2.8	3.63	V
PAVDD33	Analog Power Supply	---	2.8~3.3	3.63	V
DVDDMIO	Digital I/O Power Supply	1.62	1.8~3.3	3.63	
VDD18	AFE Power Supply	1.7	1.8	1.9	V
Operating Ambient Temperature Range		-10 to 65			°C
Storage Temperature Range		-20 to 85			°C

3.3. RF Characteristic

Item	Condition	Min.	Typ.	Max.	Unit
802.11g Transmitter					
Operating frequency range		Channel 1		Channel 14	
Transmit power level	54Mbps	13	14	15	dBm
Transmit center frequency tolerance		-10		10	ppm
Transmit modulation accuracy	54 Mbps		-31.5	-28	dB
	48 Mbps		-30	-27	dB
	36 Mbps		-29.5	-26	dB
	24 Mbps		-28	-25	dB
	18 Mbps		-27	-24	dB
	12 Mbps		-26.5	-23	dB
	9 Mbps		-26	-22	dB
6 Mbps		-26	-21	dB	
802.11b Transmitter					
Operating frequency range		Channel 1		Channel 14	
Transmit power level	2M DQPSK	15	16	17	dBm
Transmit center frequency tolerance		-25		25	ppm
802.11g Receiver					

Receiver minimum input level sensitivity (PER < 10%)	54 Mbps		-72	-70	dBm
	48 Mbps		-72	-70	dBm
	36 Mbps		-80	-77	dBm
Receiver minimum input level sensitivity (PER < 10%)	24 Mbps		-80	-77	dBm
	18 Mbps		-87	-84	dBm
	12 Mbps		-87	-84	dBm
	9 Mbps		-90	-87	dBm
6 Mbps		-90	-87	dBm	
802.11b Receiver					
Receiver minimum input level sensitivity (PER < 10%)	11 Mbps		-87	-84	dBm
	5.5 Mbps		-91	-88	dBm
	2 Mbps		-92	-90	dBm
	1 Mbps		-92	-90	dBm

4. PACKAGE INFORMATION

4.1. Signal Layout (Top View)

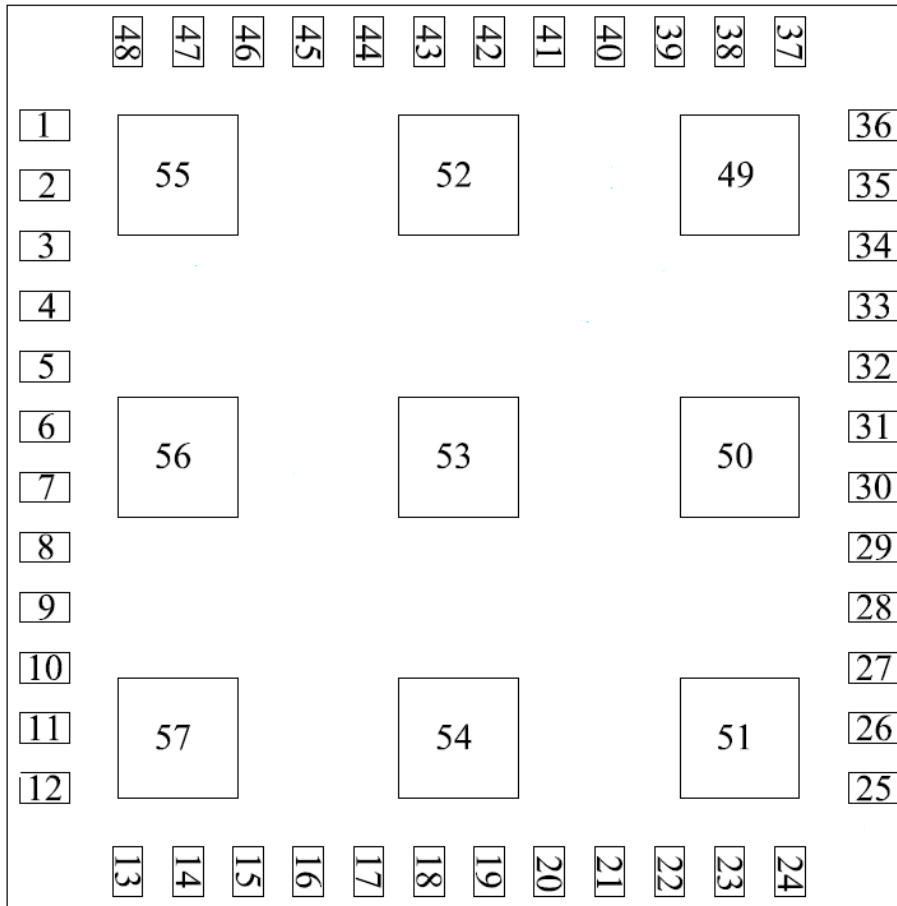

4.2. Pin Assignment

Pin No.	Pin Name	I/O	Power Domain	Description
1	WLAN_ACT	I/O	DVDD28	WLAN_ACT for 2-/3-/4- wire mode. BT-coexistence
2	BT_PRI	I	DVDD28	BT_PRI for 2-/3-/4- wire mode. BT-coexistence
3	OSC_EN	O		Oscillator enable
4	GND	P	-	Ground

5	PAVDD33	I	PAVDD33	3.3V power supply for RF PA.
6	GPIO2	I/O	DVDD28	<ul style="list-style-type: none"> ● General purpose IO 2 ● 3.3/2.8V interrupt output ● Daisy chain input for external oscillator control
7	LED1	O	DVDD33	LED Control
8	MODE1	I	DVDD33	Mode select bit 1
9	MODE0	I	DVDD33	Mode select bit 0
10	GPIO0	I/O	DVDD28	<ul style="list-style-type: none"> ● General purpose IO 0 ● BT_ACT for 3-/4-wire mode BT-coexistence ● Daisy chain input for external oscillator control
11	GND	P	-	Ground
12	GND	P	-	Ground
13	ANT_OUT	I/O	-	WLAN RF antenna port
14	GND	P	-	Ground
15	D5	I/O	DVDDMIO	eHPI 8/16 data bus bit 5
16	D6	I/O	DVDDMIO	eHPI 8/16 data bus bit 6
17	GND	P	-	Ground
18	VDD18	P	VDD18	1.8V power input
19	D7	I/O	DVDDMIO	eHPI 8/16 data bus bit 7
20	D8	I/O	DVDDMIO	eHPI 8/16 data bus bit 8
21	D9	I/O	DVDDMIO	eHPI 8/16 data bus bit 9
22	D10	I/O	DVDDMIO	eHPI 8/16 data bus bit 10
23	D11	I/O	DVDDMIO	eHPI 8/16 data bus bit 11
24	D12	I/O	DVDDMIO	eHPI 8/16 data bus bit 12
25	D14	I/O	DVDDMIO	eHPI 8/16 data bus bit 14
26	D4	I/O	DVDDMIO	eHPI 8/16 data bus bit 4
27	D2	I/O	DVDDMIO	<ul style="list-style-type: none"> ● eHPI 8/16 data bus bit 2 ● SDIO data bus bit 2
28	D3	I/O	DVDDMIO	<ul style="list-style-type: none"> ● eHPI 8/16 data bus bit 3 ● SDIO data bus bit 3
29	GND	P	-	Ground
30	CS_N	I/O	DVDDMIO	<ul style="list-style-type: none"> ● eHPI 8/16 chip select ● SDIO command bus

31	A0	I	DVDDMIO	<ul style="list-style-type: none"> ● eHPI 8/16 address select ● SDIO clock input
32	GPIO1	I/O	DVDD28	<ul style="list-style-type: none"> ● General purpose IO 1 ● BT_FREQ for 4-wire mode BT-coexistence ● Daisy chain input for external oscillator control
33	D0	I/O	DVDDMIO	<ul style="list-style-type: none"> ● eHPI 8/16 data bus bit 0 ● SDIO data bus bit 0
34	D13	I/O	DVDDMIO	eHPI 8/16 data bus bit 13
35	D1	I/O	DVDDMIO	<ul style="list-style-type: none"> ● eHPI 8/16 data bus bit 1 ● SDIO data bus bit 1
36	INT_N	O	DVDDMIO	Host interface interrupt output
37	EXT_RST_N	I	DVDD28	External hardware reset
38	WE_N	I	DVDDMIO	eHPI 8/16 write strobe
39	OE_N	I	DVDDMIO	eHPI 8/16 read strobe
40	D15	I/O	DVDDMIO	eHPI 16 data bus bit 15
41	DVDDMIO	I	DVDDMIO	Host interface power input
42	GND	P	-	Ground
43	XIN_32K	I	DVDD33	External 32.768KHZ clock input
44	GND	P	-	Ground
45	DVDD28	I	DVDD28	2.8V digital power input
46	GND	P	-	Ground
47	DVDD33	I	DVDD33	3.3V digital power input
48	GND	P	-	Ground
49 ~ 57	GND	P	-	Ground

I = input; O = output; IO = bidirectional; P = power pin (VDD, ground or LDO output)

4.3. Module Marking



Date Code: **YYWWSSF**

YY = Digit of the year, ex: 2008=08

WW = Week (01~53)

SS = Serial number from 01 ~99 match to manufacture's lot number

F = 1 for Taiwan

5. MECHANICAL CHARACTERISTICS

5.1. Module Dimension

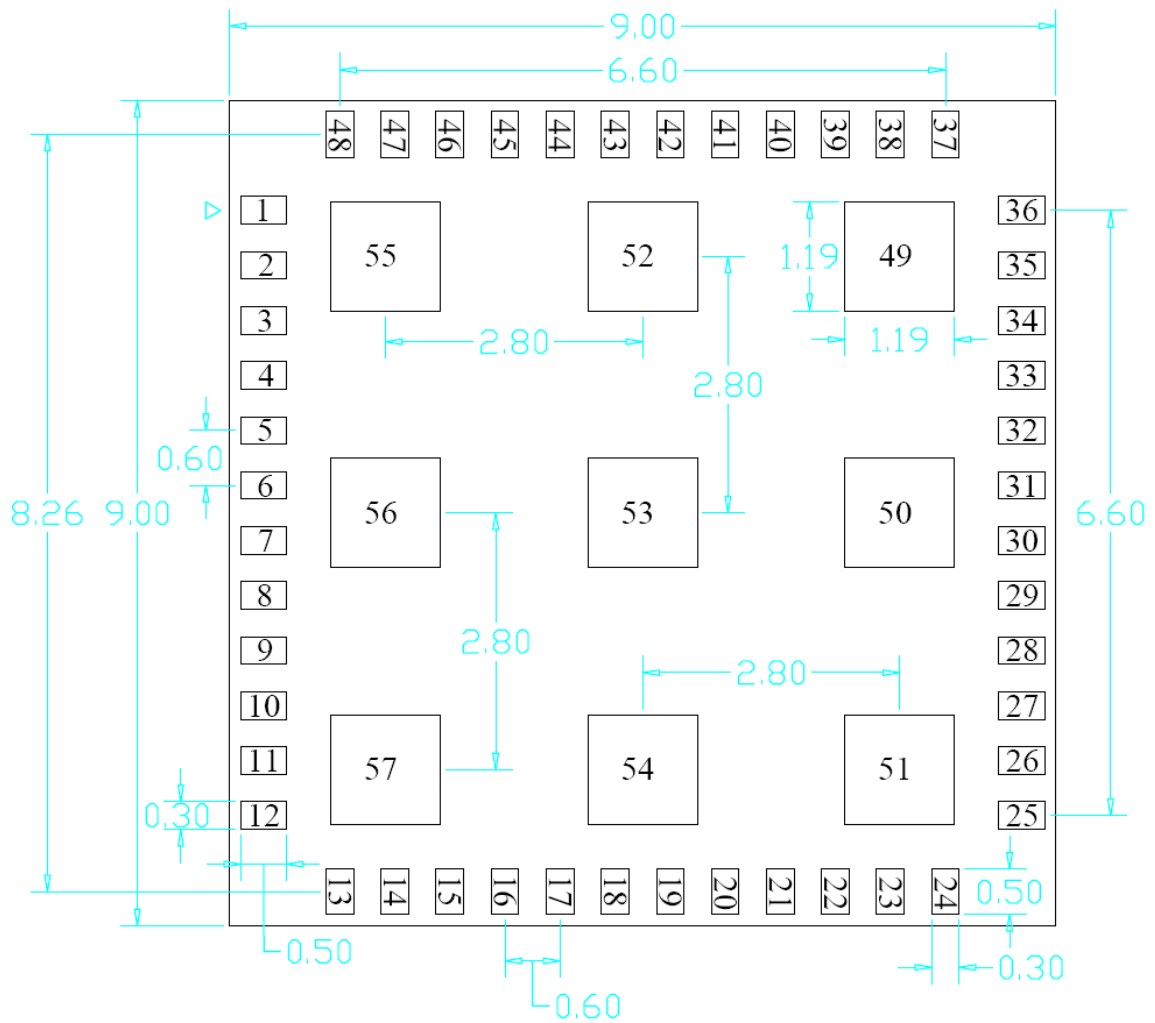

Unit: mm

5.2. Recommended Footprint

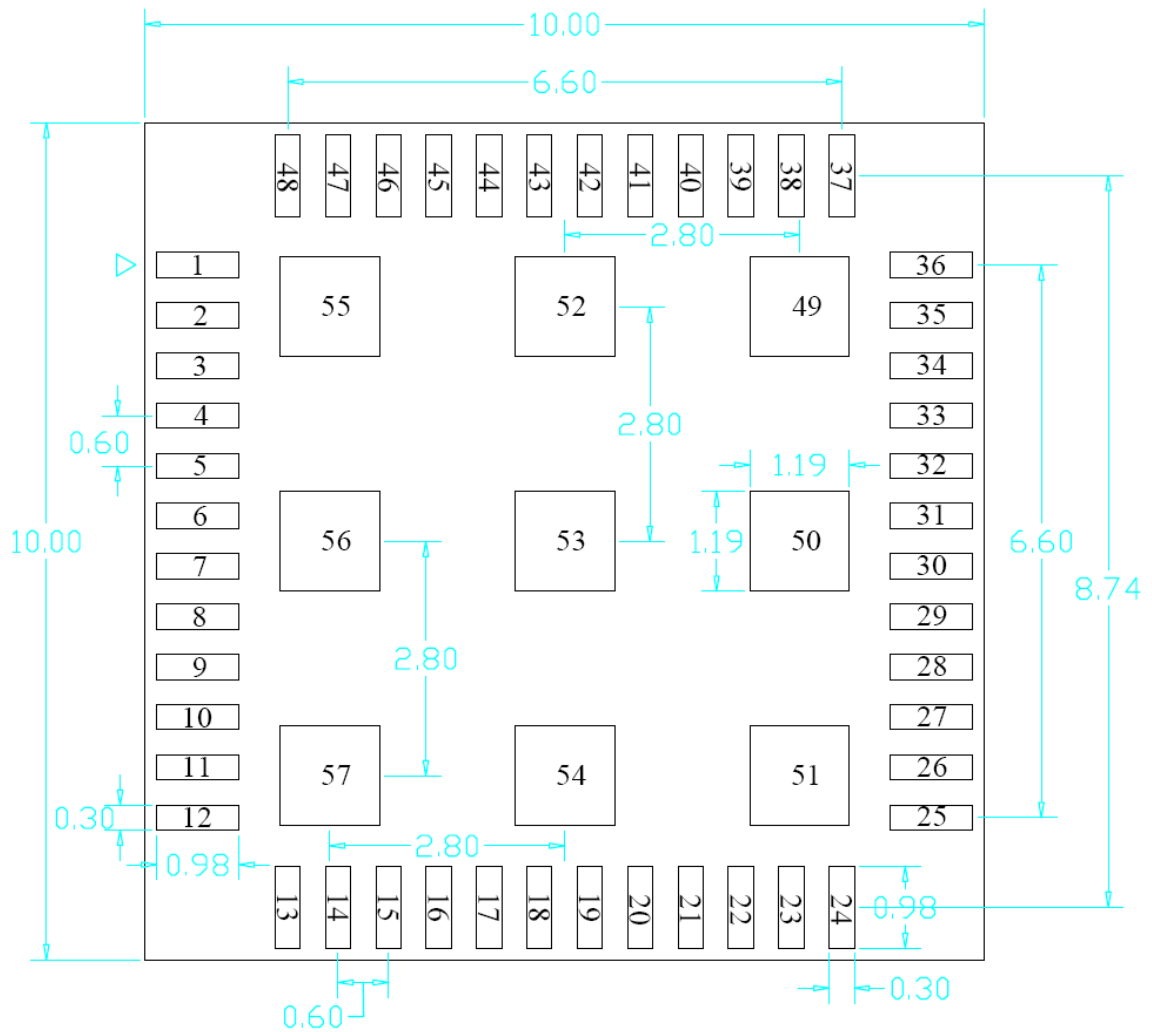

Unit: mm

6. SMT & BAKING RECOMMENDATION

6.1. Baking Recommendation

- Baking condition :
 - Follow MSL Level 4 to do baking process.
 - After bag is opened, devices that will be subjected to reflow solder or other high temperature process must be
 - a) Mounted within 72 hours of factory conditions <30°C/60% RH,
 - or
 - b) Stored at <10% RH.
 - Devices require bake, before mounting, if Humidity Indicator Card reads >10%

If baking is required, Devices may be baked for 24 hrs at 125 °C.

6.2. SMT Recommendation

- **Recommended Reflow profile :**

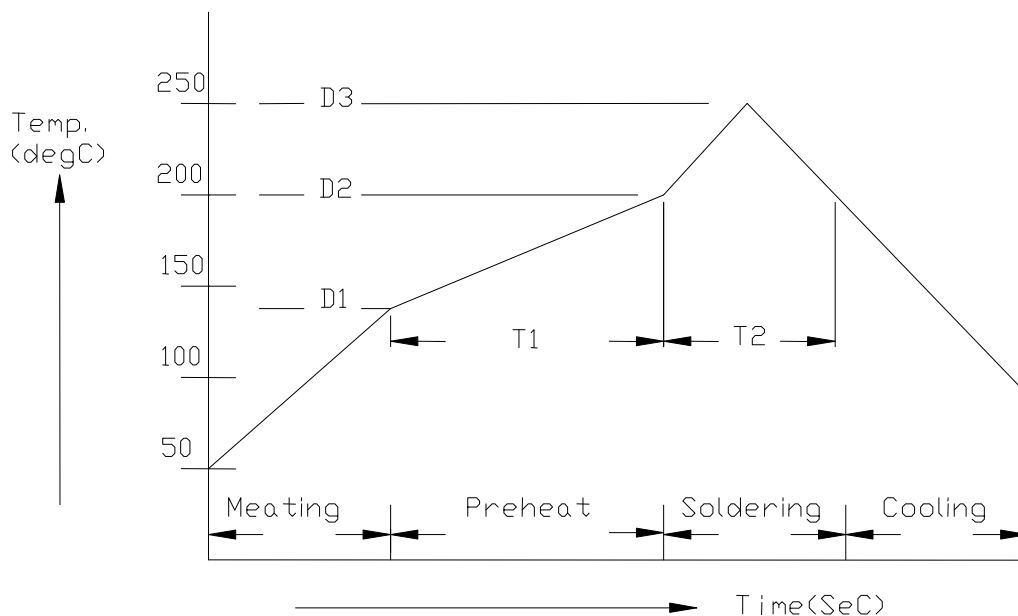

No.	Item	Temperature (°C)	Time (sec)
1	Pre-heat	D1: 140 ~ D2: 200	T1: 60 ~ 120
2	Soldering	D2: >= 200	T2: 80 max
3	Peak-Temp.	D3: 250 °C max	

Note: (1) Reflow soldering is recommended two times maximum.
 (2) Add Nitrogen while Reflow process : SMT solder ability will be better.

- **Stencil thickness** : 0.13~ 0.15 mm
- **Soldering paste (without Pb)** : Recommended SENJU N705-GRN3360-K2-V can get better soldering effects.
- Module suggested wetting Flux before mounting if printed circuit board is immersion Tin substrate.