

WH7016C

Thermostat Product Manual



Shenzhen Willhi Electronics Co., Ltd.
Tel :0755 -29539385 Fax :86-0755 -2953 9395
Technical support: Engineer Tian

□ **Installation opening size:**

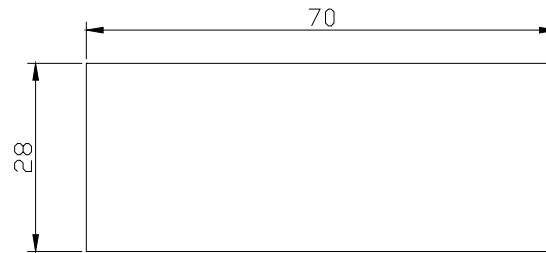

□ **Wiring diagram:**

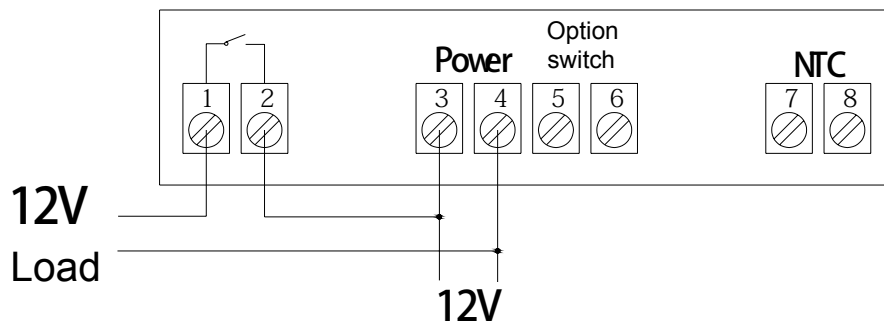

Terminals 1 and 2: Normally opened contact of relay

Terminals 3 and 4: Connect the power 12V

Terminals 5 and 6: The factory parameter settings of thermostat can be locked after a short circuit, the user can not modify.

Terminals 7 and 8: Temperature connection sensor

Note: The load refers to the heating or cooling equipment on control.

□ **Electrical performance:**

Temperature measurement range: $-50 \square \sim 110 \square$

Temperature control range: $-50 \square \sim 110 \square$

Temperature measurement error: $\pm 0.5 \square$

Sensor Type: NTC (10K/3435)

Control accuracy: $1 \square$

Working voltage: AC/DC12V

Working current: $<2W$

Relay contact point current: AC 7A/220V

Data storage : Yes

Working temperature: $0 \square \sim 50 \square$

Storage temperature: $-10 \square \sim 60 \square$

□ **Key Instructions:**

1. RST: Press RST key to switch on and off, press the RST key on the power-off state once to turn on, on the power-on state, press the RST key for three seconds and hold on, then it will be off.

2. SET:

A: Press the SET key once to enter the temperature control setting, press ▲ or ▼ button to adjust, press ▲ or ▼ button for three seconds and hold to enter the fast adjusting mode, press the SET key again to exit setting mode.

B: Press and hold SET key for three seconds to enter the system menu settings, press the ▲ or ▼ key to select the adjustment menu, press SET key once to enter the appropriate parameter settings, press ▲ or ▼ to adjust the parameters needed to be modified, after being adjusted, press the RST key to exit, or exit as the system delay for 5 seconds.

▲: Up key

▼: Down key

□ **Operating Instructions:**

LED Status Description:

The **WORK** lights at the left side of the screen is used as working indicator lights, flashing is to indicate the delay of cooling or heating, if the LED is always on, it indicates it is on the status of cooling or heating.

The **SET** light at the left side of the screen lights is used as setting indicator lights, if the LED is always on, it indicates it is on the status of setting.

Function Instructions:

Press **RST** key to open the thermostat, on the running status, press this key for 3 seconds, then the thermostat can be turned off.

□ **Cooling, heating function:**

Cooling Mode: When the measured temperature is higher than or equal to the set value + hysteresis, the relay picks up to start the output; When the measured temperature below the set value, the relay off and close the output.

Heating mode: When the measured temperature is higher than or equal to the set value, the relay off, turn off the output; When the measured temperature below the set value - hysteresis, the relay picks up to start the output.

Example for Setting: If it is set to heating mode, set the temperature to 25 degrees, hysteresis is set to 5, then when the measured temperature is higher than or equal to 25 degrees, the relay is off, close the output.

When the temperature is below 20 degrees, pick up the relay again, to start the output.

Example for Setting: If it is set to cooling mode, set the temperature to 25 degrees, hysteresis is set to 5, then when the measured temperature is below 25 degrees, the relay is off, close the output. When the temperature is higher than or equal to 30 degrees, pick up the relay again, to start the output.

□ **Cooling, heating mode setting:**

Press "SET" key and hold more than 3 seconds to enter the menu display, the screen appears "HC" code, press the "SET" key to display the working mode, press the "▲" or "▼" to adjust the display, C means cooling mode; H means heating mode.

□ **Hysteresis function:**

Hysteresis setting limits the maximum interval between the opening and stopping, this machine minimum interval between the opening and stopping is

1 □, the maximum is 15 □.

□ **Hysteresis settings:**

Press "SET" key and hold more than 3 seconds to enter the menu display, with "▲" or "▼" key adjusted to the screen, appearing "D" code, press the "SET" key to display the hysteresis set value, press "▲" "Or" "▼"key to adjust the parameters.

□ **Temperature calibration funtion:**

When there is deviation between the measuring temperature and standard temperature, use the temperature calibration function, make the machine measurements value consistent with the standard temperature, the after calibration temperature= the before calibration temperature + calibration value (calibration value can be positive number, negative number, and 0) .

□ **Temperature calibration settings:**

Press "SET" key and hold more than 3 seconds to enter the menu display, with "▲" or "▼" key adjusted to the screen, appearing "CA" code, press the "SET" key to display the temperature calibration settings, press "▲" "Or" "▼"key to adjust the parameters.

For example: When we measure the probe temperature was 25 degrees,it displays 25 degrees as the CA is 0, it displays 26 degrees as the CA is 1, it displays 24 degrees as the CA is -1. This function is generally applied when the probe can not measure directly the measured object. For example, we place the probe at the outside of a cup to measure its water temperature, we need to adjust the CA parameters because of the heat loss of the cup, so that the display temperature can be in accordance with cup temperature.

□ **Delay Protection Funtion:**

In the cooling mode, the first power on, when the measured value above the set value + hysteresis value, the machine will not immediately start cooling, it needs to set the delay time, then the machine can run to start cooling; once the interval between two cooling is larger than the delay time, the machine immediately starts cooling, once the interval between two cooling is less than the delay time, the machine must run the remaining delay time to start cooling. The delay time is started to calculate from stopping the machine. The delay time of heating mode is as same as the cooling mode.

Note: It is recommended that only the device that use compressor cooling can use the delay start function, the user who don't need delay start function please set this parameter to 0.

□ **Delay Protection Setting:**

Press "SET" key and hold more than 3 seconds to enter the menu display, with "▲" or "▼" key adjusted to the screen, appearing "PT" code, press the "SET" key to display the delay setting value, then press the "▲" "or" "▼"key to adjust the parameters.

□ **Upper and lower limit functions:**

The setting of HS and LS limit the set range of control temperature point , for example: HS is set to +15, LS is set to -10, the control temperature can only be adjusted between -10 and +15, when the control temperature to -10 then press "▼" key, the display will remain on the status of -10 and not decrease; when the control temperature to +15 then press "▲" key, the display will on the status of 15 and not incese. If the set point outside this range, it needs to firstly change the value of HS and LS, then it can be achieved.

□ **Upper and lower limit settings:**

Press "SET" key and hold more than 3 seconds to enter the menu display,

with "▲" or "▼" key adjusted to the screen, appearing "HS" or "LS" code, press the "SET" key to display the upper or lower limit set value, Then press "▲" or "▼" key to adjust the parameters. HS means upper limit. LS means lower limit.

For example: the upper and lower limits are used to limit the range of control temperature that can be set, such as: LS is 10, HS 20, then press the SET key to adjust the temperature control, it can only be varied between 10 and 20.

Menu code selection:

Symbol	Details	Setting range	Factory settings	Units
HC	Heating / cooling	H/C	C	
D	Hysteresis	1~15	5	<input type="checkbox"/>
LS	The minimum set limit	-50~110	-50	<input type="checkbox"/>
HS	The maximum set limit	-50~110	110	<input type="checkbox"/>
CA	Temperature calibration	-5~+5	0	<input type="checkbox"/>
PT	Delay time	0~10	1	Minutes

fault tips:

1)When the sensor disconnected, the screen displays --- and close the heating wire

2)When the sensor detects the temperature is below -50 degrees, the screen displays LLL

3)When the sensor detects a temperature higher than 110 degrees, the screen displays HHH

Caution for using:

Cooling, heating load must not exceed the output contact capacity, or it may result in machine damage and cause a fire.

Various connecting wire must be well connected with the terminal, otherwise, it would result in reducing the reliability of machine.

When connecting the wire, please separate power supply, relays, sensors, otherwise it will damage the machine.