

WL2803E

Ultra low dropout, 500mA, CMOS LDO

[Http://www.sh-willsemi.com](http://www.sh-willsemi.com)

Descriptions

The WL2803E series are ultra low dropout, Low quiescent current, high PSRR CMOS LDO. The dropout voltage is 130mV (Typ.) at 500mA load current.

Using CMOS construction, the quiescent current consumed by the WL2803E is typically 150uA over the entire input voltage range, making it attractive for consumer, networking applications that demand high output current. The WL2803E series are available in wide output voltage range version from 1.2V to 3.3V with 0.1V step.

The WL2803E series offer thermal shutdown (OTP) and current limit functions, to assure the stability of chip and power system at wrong condition, and it uses trimming technique to guarantee output voltage accuracy within $\pm 2\%$.

The WL2803E regulators are available in SOT-23-5L packages. Standard products are Pb-free and Halogen-free.

Features

- Input voltage : 2.5V~5.5V
- Output voltage : 1.2V, 1.8V, 3.3V
(Or upon request)
- Output current : 500mA
- PSRR : 65dB @ 1KHz
- Dropout voltage : 130mV @ $I_{OUT}=0.5A$
- Output noise : 100uV
- Quiescent current : 150 μ A Typ.

Applications

- LCD TV
- STB
- Computer, Graphic card
- Network communication equipments
- Others portable electronics devices



SOT-23-5L

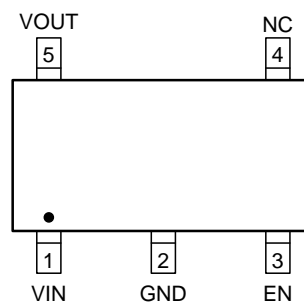

Pin Configuration (Top View)

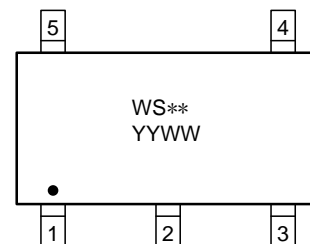

WS = Device code
 ** = Voltage code (33: 3.3V)
 YY = Year code
 WW = Week code

Marking

Order Information

For detail information, Please refer to page 9.

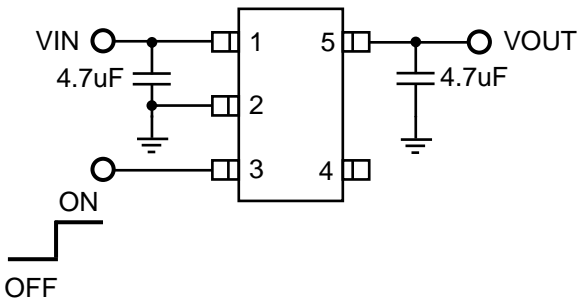
Typical Application

Pin Description

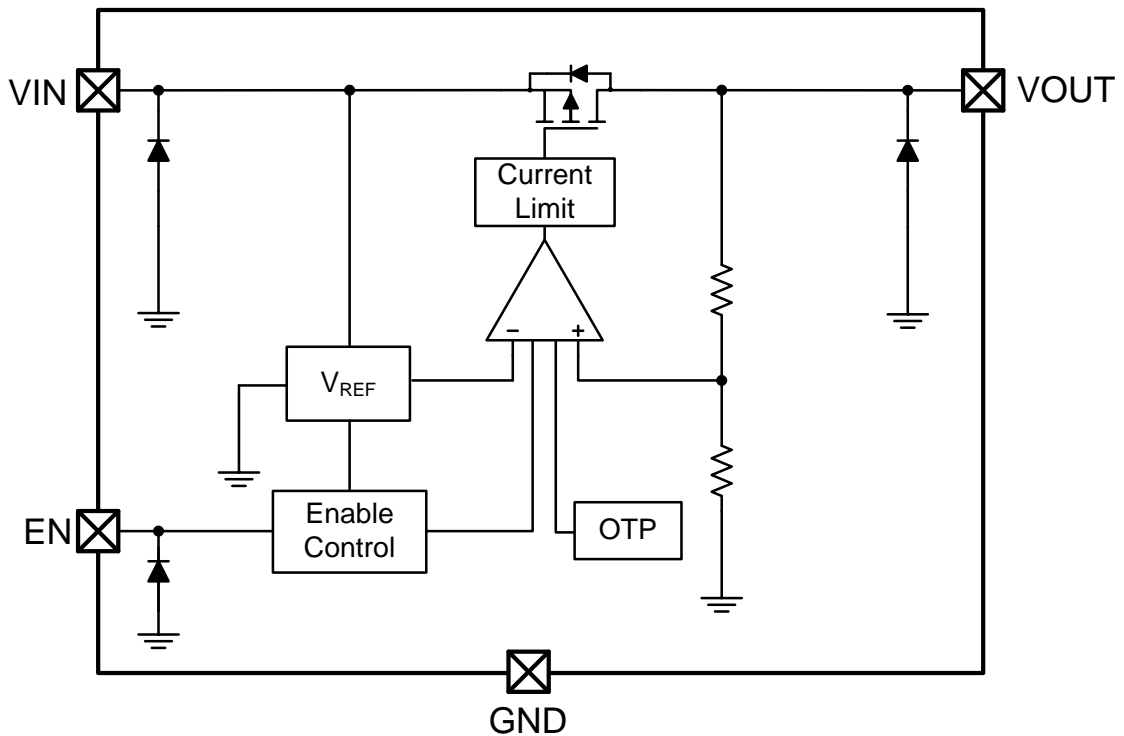
PIN	Symbol	Description
1	VIN	Input
2	GND	Ground
3	EN	Enable, Active High
4	NC	Not connect
5	VOUT	Output

Block Diagram

Absolute Maximum Ratings

Parameter	Symbol	Value	Unit
Input voltage range	V_{IN}	-0.3~6.5	V
Output voltage range	V_{OUT}	-0.3~ V_{IN}	V
Power dissipation *1 *3	P_D	0.7	W
Power dissipation *2 *3		0.5	W
Thermal resistance *1	$R_{\theta JA}$	180	°C/W
Thermal resistance *2		250	°C/W
Junction temperature	T_J	150	°C
Lead temperature(10s)	T_L	260	°C
Storage temperature	Tstg	-55 ~ 150	°C
ESD Ratings	HBM	±8000	V
	MM	±400	V

Note: These are stress ratings only. Stresses exceeding the range specified under “Absolute Maximum Ratings” may cause substantial damage to the device. Functional operation of this device at other conditions beyond those listed in the specification is not implied and prolonged exposure to extreme conditions may affect device reliability.

*1: Surface mounted on FR-4 Board using 1 square inch pad size, dual side, 1oz copper

*2: Surface mounted on FR-4 board using minimum pad size, 1oz copper

*3: Power dissipation is calculate by $P_D = (V_{IN}-V_{OUT}) \times I_{OUT}$

Recommend Operating Ratings

Parameter	Symbol	Value	Unit
Operating Supply voltage	V_{IN}	2.5~5.5	V
Operating Temperature Range	Topr	-40~85	°C

Electronics Characteristics (Ta=25°C, V_{IN}=V_{OUT}+1V, C_{IN}=C_{OUT}=4.7uF, unless otherwise noted)

Parameter	Symbol	Condition	Min.	Typ.	Max.	Unit
Output Voltage	V _{OUT}	V _{OUT} < 1.5V, V _{IN} =2.5V, I _{OUT} =1mA	V _{OUT} - 30mV	V _{OUT}	V _{OUT} + 30mV	V
		V _{OUT} ≥ 1.5V, I _{OUT} =1mA	V _{OUT} * 0.98	V _{OUT}	V _{OUT} * 1.02	
Dropout Voltage	V _{DROP}	V _{OUT} =V _{OUT} *0.98, I _{OUT} =1A		250	450	mV
Current Limit	I _{LIM}	V _{IN} =5V	0.65			A
Line Regulation	ΔV _{LINE}	V _{OUT} =3.3V, V _{IN} =4.3~6.0V, I _{OUT} =1mA		5	10	mV
Load Regulation	ΔV _{Load}	V _{OUT} =3.3V, I _{OUT} =1~500mA		10	30	mV
Quiescent Current	I _Q	V _{OUT} =3.3V, I _{OUT} =0		150	200	uA
Shut-down Current	I _{SHDN}	V _{EN} = 0V		0.1	1.0	uA
Power Supply Ripple Rejection	PSRR	V _{IN} =(V _{OUT} +1V) _{DC} +0.2V _{P-P} F=1KHz, I _{OUT} =10mA		65		dB
		V _{IN} =(V _{OUT} +1V) _{DC} +0.2V _{P-P} F=10KHz, I _{OUT} =10mA		58		
Output noise voltage	e _{NO}	10Hz to 100KHz, C _{OUT} =4.7μF		100		μV _{P-P}
EN logic high voltage	V _{ENH}	V _{IN} =5.5V, I _{OUT} =1mA	1.2			V
EN logic low voltage	V _{ENL}	V _{IN} =5.5V, I _{OUT} =0mA			0.4	V
Thermal shutdown threshold	T _{SD}			165		°C
Thermal shutdown hysteresis	Δ T _{SD}			30		°C

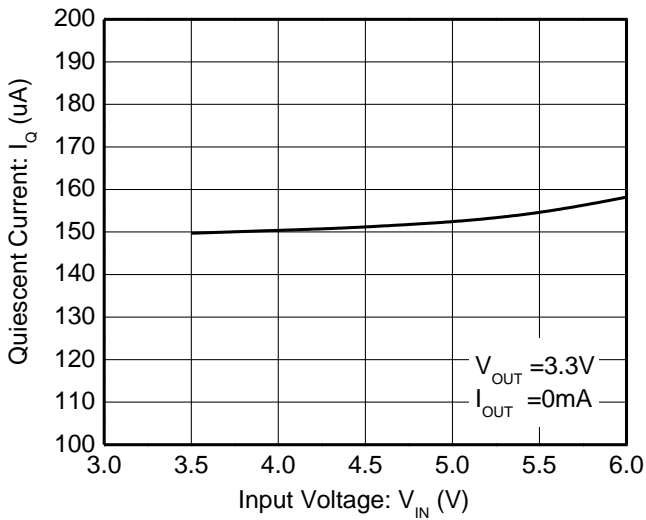
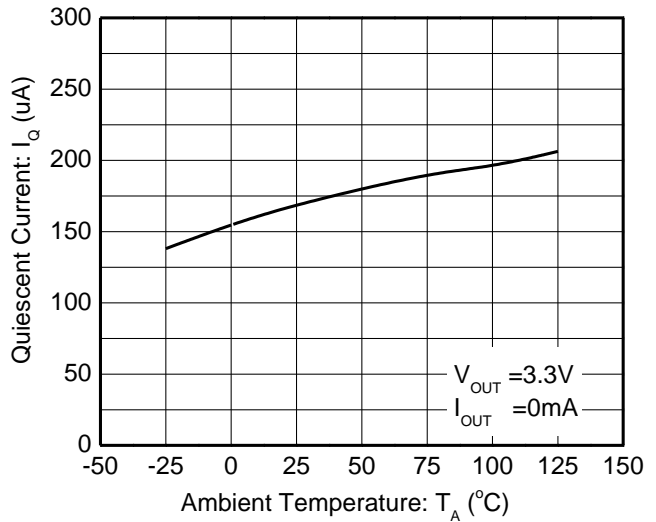
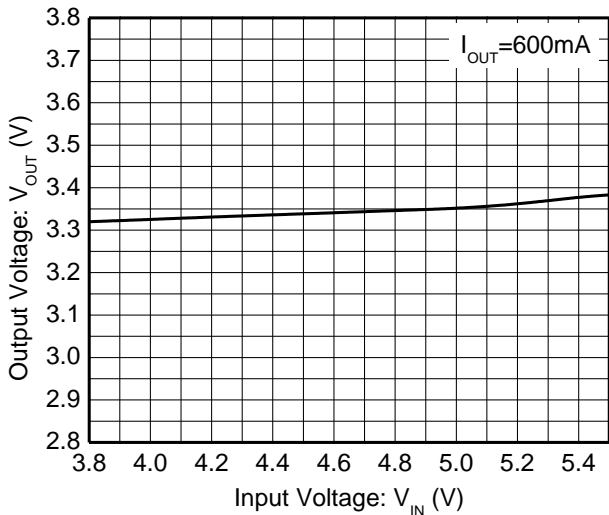
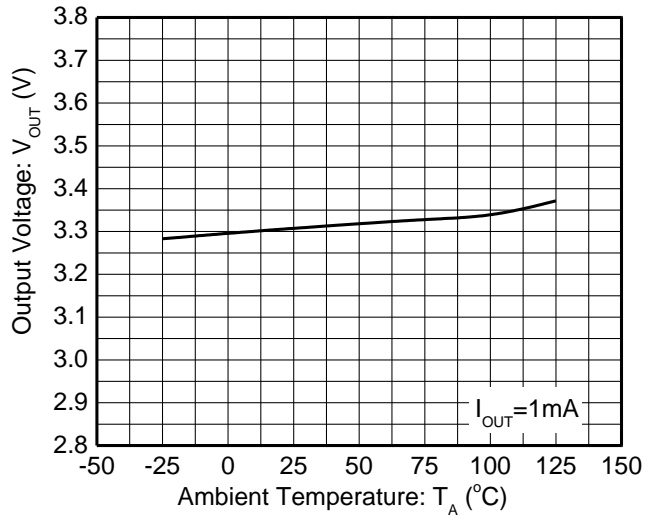
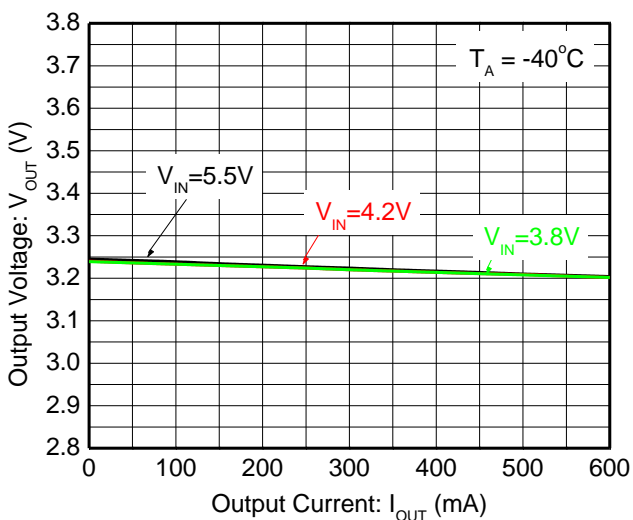
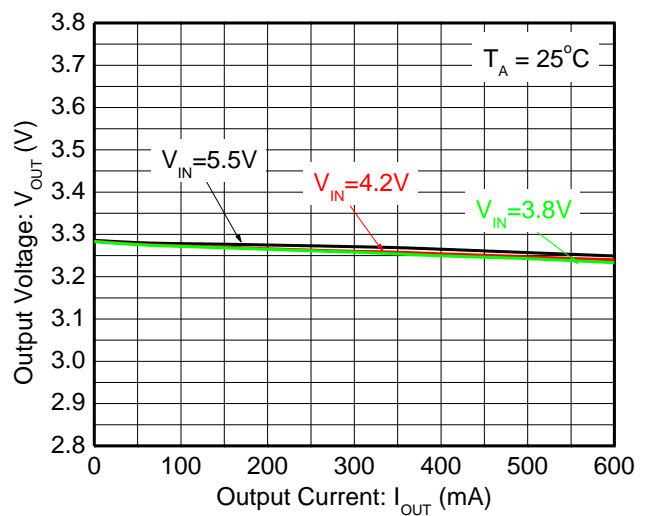
Typical characteristics ($T_a=25^\circ\text{C}$, $V_{IN}=V_{OUT}+1\text{V}$, $C_{IN}=C_{OUT}=4.7\mu\text{F}$, unless otherwise noted)

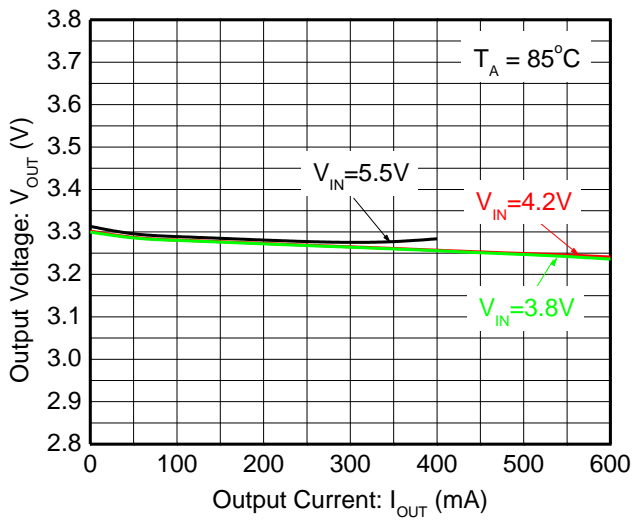
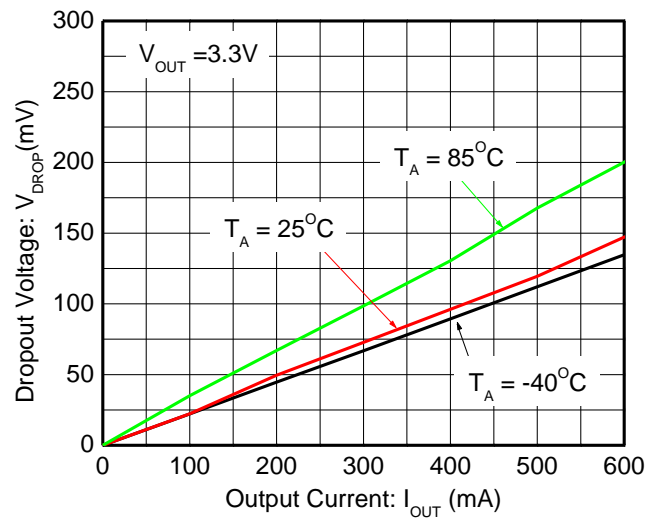
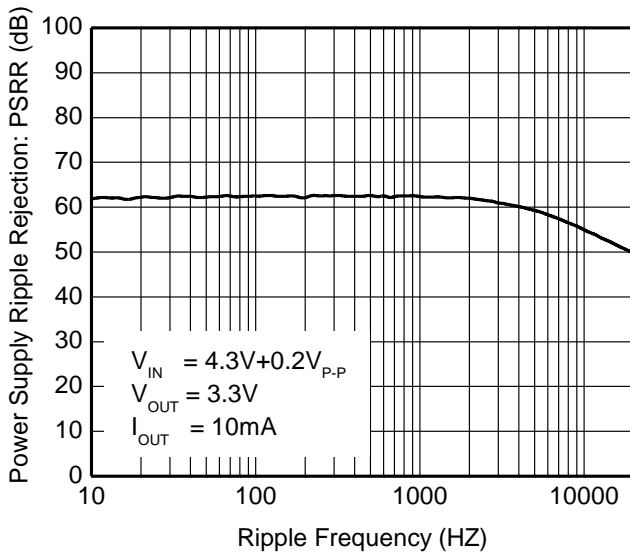
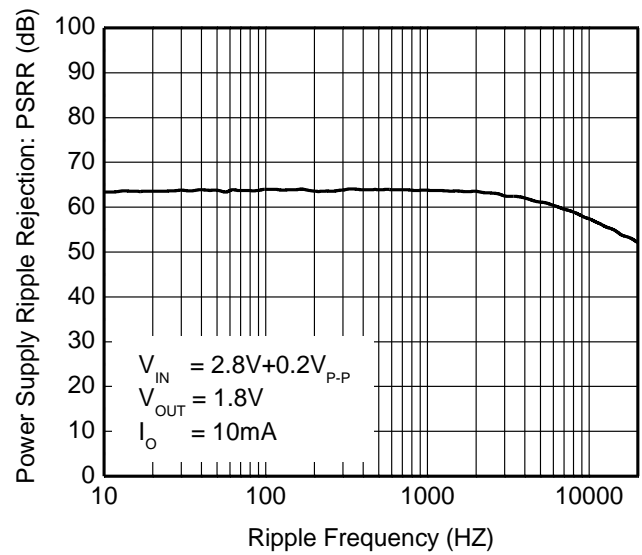
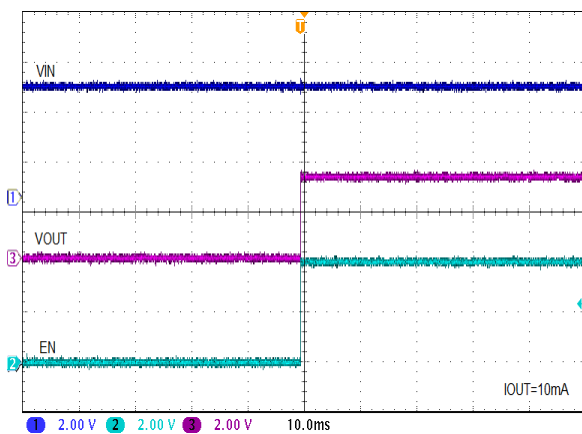
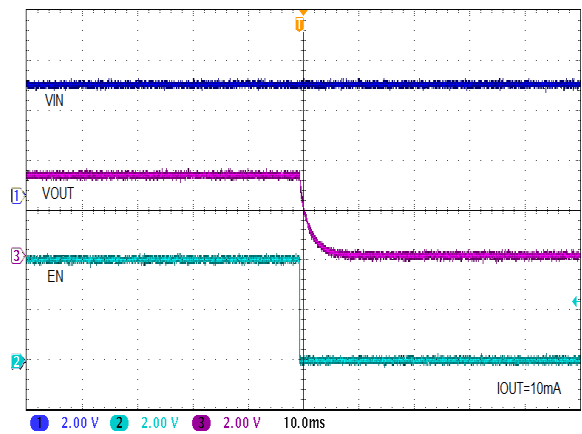
Quiescent current vs. Supply voltage

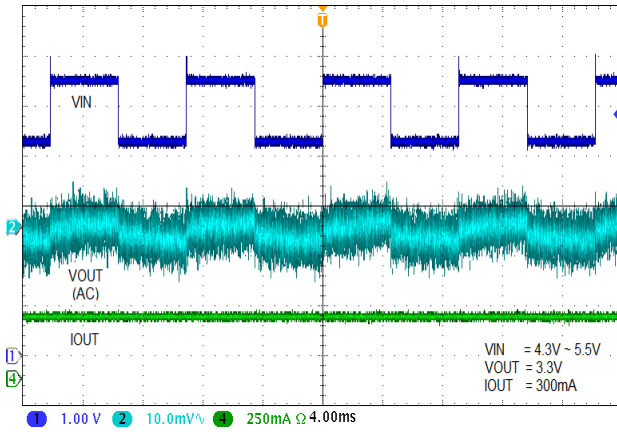
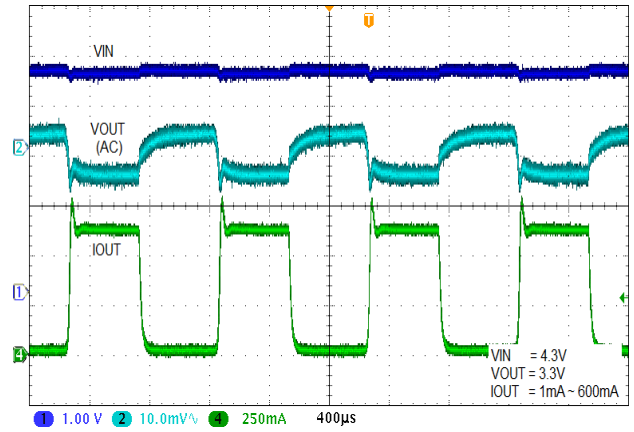
Quiescent current vs. Ambient temperature

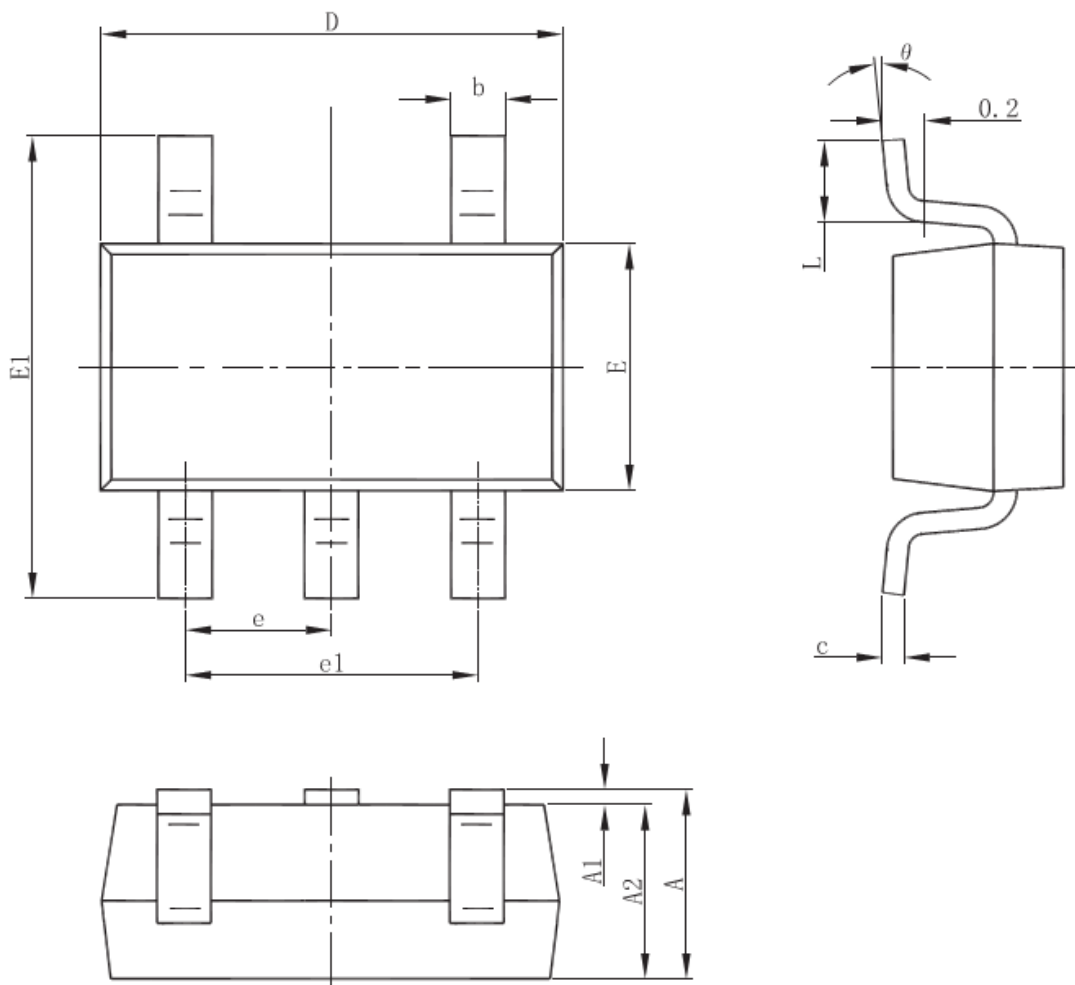
Output voltage vs. Supply voltage

Output voltage vs. Ambient temperature

Output voltage vs. Output current

Output voltage vs. Output current

Output voltage vs. Output current

Dropout voltage vs. Output current

PSRR

PSRR

Startup with EN

Shutdown with EN

Line Regulation

Load Regulation

Package outline dimensions
SOT-23-5L

Symbol	Dimensions In Millimeters		
	Min.	Typ.	Max.
A	1.050	-	1.250
A1	0.000	-	0.100
A2	1.050	-	1.150
b	0.300	0.4	0.500
c	0.100	-	0.200
D	2.820	2.9	3.020
E	1.500	1.6	1.700
E1	2.650	2.8	2.950
e	0.950 (Basic)		
e1	1.800	1.9	2.000
L	0.300	0.45	0.600
θ	0°	-	8°

ORDER INFORMATION

Ordering No.	V _{OUT} (V)	Package	Marking	Operating Temperature	Shipping
WL2803E12-5/TR	1.2	SOT-23-5L	WS12/YYWW	-40 ~ +85°C	3000/Tape and Reel
WL2803E18-5/TR	1.8	SOT-23-5L	WS18/YYWW	-40 ~ +85°C	3000/Tape and Reel
WL2803E30-5/TR	3.0	SOT-23-5L	WS30/YYWW	-40 ~ +85°C	3000/Tape and Reel
WL2803E33-5/TR	3.3	SOT-23-5L	WS33/YYWW	-40 ~ +85°C	3000/Tape and Reel