



WL660X Datasheet

***Single Mode Bluetooth Low Energy SoC
Preliminary Specification***

1 General Description

1.1 Overview

The WL660X chip is a very low power, high performance and highly integrated SoC with Bluetooth 5.0 BLE transceiver. It integrates a high-performance 2.4GHz RF transceiver, rich features baseband, 32 bit MCU and various peripheral IOs. It support 1 Mbit FLASH and 128KByte RAM to enable programmable protocol and profile to support customized applications.

The WL660X is manufactured using advanced 55nm CMOS low leakage process, which offers highest integration, lowest power consumption, lowest leakage current and reduced BOM cost while simplifying the overall system design. Rich peripherals include an 8 channel general purpose ADC, power-on-reset(POR), 3axis Q-decoder, UART/SPI/I2C and up to 19 GPIOs, which further reduce overall system cost and size.

The WL660X operates with a power range from 1.8 to 5.5V and very low power consumption in both Tx and Rx modes, enabling long lifetimes in battery-operated systems while maintaining excellent RF performance. The device can enter an ultra low power sleep mode in which the registers and retention memory content are retained while low power oscillator and sleep timer are ON. The QFN4x4_32 (up to 19 GPIOs) Package is available

1.2 Block Diagram

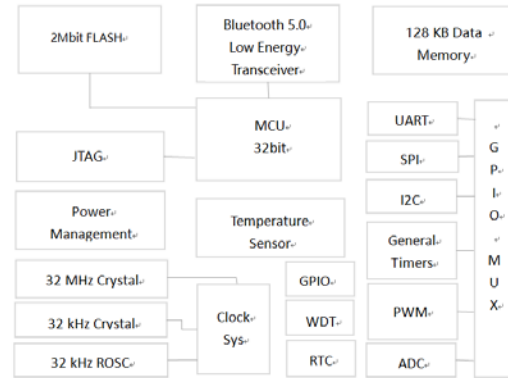

1.3 Application

- HID Application
- Lighting Control
- Wireless Sensor Networks
- 3D Glassed
- Proximity and Find Me

1.4 Features

- Bluetooth 5.0 BLE RF SOC
- Operation voltage 1.8 V to 3.6 V
- Operation voltage 3.1 V to 5.5 V (ON-CHIP 5V LDO)
- -94 dBm Sensitivity@1Mbps
- Maximum 6 dBm output power
- Low Jitter 32K RC oscillator
- 32bit MCU Integrated
- 4-wires ext.-FLASH Interface
- 128 KByte data RAM
- I2Cs, SPI and UART Interface
- 10-channel 10-bit General ADC
- PWM(max 6, 2 wi inv)
- keyscan
- 3 axis Q-decoder
- Low Power Real Time Counter
- 1 uA in Sleep Mode
- 12 uA in Suspend Mode
- 16 mA Transceiver RX Active
- 17 mA Transceiver TX Active
- QFN 4x4 32-pin Package

2 WL660X系列产品选择

产品型号	封装形式	GPIO	Flash	OTA	5V LDO
WL6601	SOP16	9	2Mbit	Y	N
WL6602	SSOP16	9	1Mbit	Y	Y
WL6603	QFN32 4x4mm	19	2Mbit	Y	Y

3.1 Pin Information (4X4mm QFN32 WL6601) The

pin assignment for QFN32 package is shown in picture below.

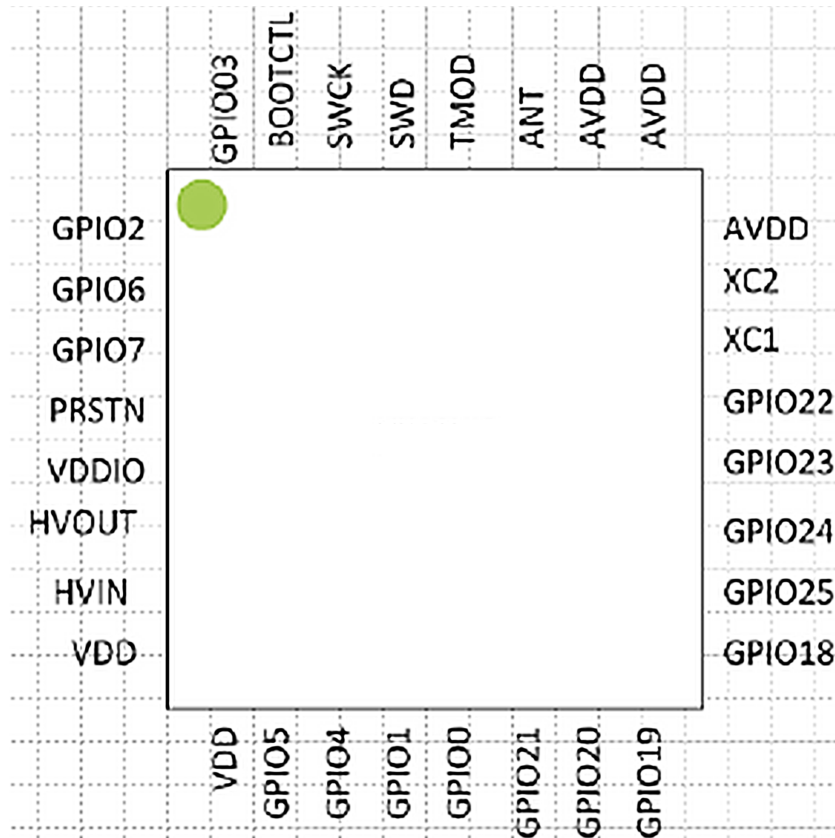

NO	Name	Description
1	GPIO2	General I/O
2	GPIO6	General I/O
3	GPIO7	General I/O
4	PRSTN	Reset signal, low active
5	VDDIO	3V power supply
6	HVOUT	Li battery/5V LDO out 2.85V
7	HVIN	Li battery/5V LDO in 3.1~5.5V
8	VDD	The output of digital LDO, 100nF decap cap
9	VDD	The output of digital LDO, 1uF decap cap
10	GPIO5	General I/O/GADC input7
11	GPIO4	General I/O/GADC input6
12	GPIO1	General I/O/GADC input5
13	GPIO0	General I/O/GADC input4
14	GPIO21	General I/O/GADC input0/32K crystal in
15	GPIO20	General I/O/GADC input1/32K crystal out
16	GPIO19	General I/O/GADC input2/uart_rx
17	GPIO18	General I/O/GADC input3/uart_tx

18	GPIO25	General I/O
19	GPIO24	General I/O
20	GPIO23	General I/O
21	GPIO22	General I/O
22	XC1	The input of 32M crystal oscillator
23	XC2	The output of 32M crystal oscillator
24	AVDD	3V power supply
25	AVDD	3V power supply
26	AVDD	3V power supply
27	ANT	The input of RF
28	TMOD	Enable the testing function
29	SWD	SWI data/ General I/O
30	SWCK	SWI clk/ General I/O
31	BOOTCTL	Chip boot mode control/ General I/O
32	GPIO03	General I/O

3.2 Pin Information (WL6602 SSOP16)

The pin assignment for SSOP16 package is shown in picture below.

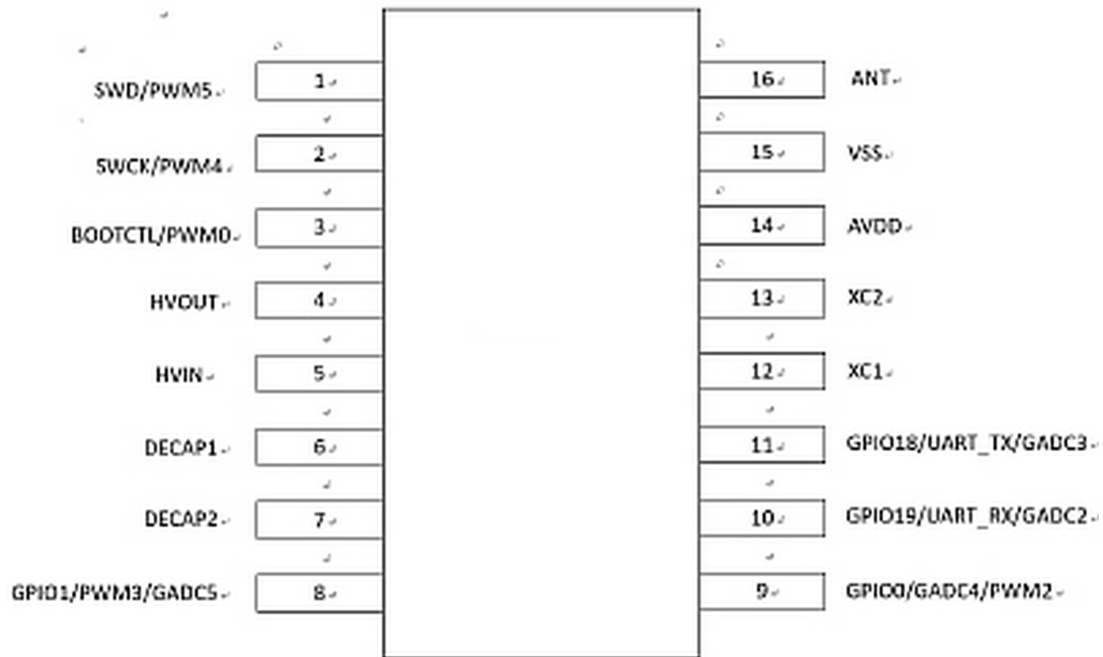

NO	Name	Description
1	SWD	SWI data/ General I/O/PWM5
2	SWCK	SWI clk/ General I/O/PWM4
3	BOOTCTL	Chip boot mode control/ General I/O/PWM0(PWM0 INVERTING can mux to pin1,2,8,9,10,11)
4	HVOUT	Li battery/USB LDO out 2.8V, typically 1uF decouple cap
5	HVIN	Li battery/USB LDO in 3~5.5V, typically 4.7uF decouple cap
6	DECAP1	The output of digital LDO, 100nF decap cap
7	DECAP2	The output of digital LDO, 1uF decap cap
8	GPIO1	General I/O/GADC input5/PWM3
9	GPIO0	General I/O/GADC input4/PWM2
10	GPIO19	General I/O/GADC input2/uart_rx
11	GPIO18	General I/O/GADC input3/uart_tx
12	XC1	The input of 32M crystal oscillator
13	XC2	The output of 32M crystal oscillator
14	AVDD	3V power supply
15	VSS	GND
16	ANT	The input of RF

3.3 Pin Information (WL6601 SOP16)

The pin assignment for SOP16 package is shown in picture below.

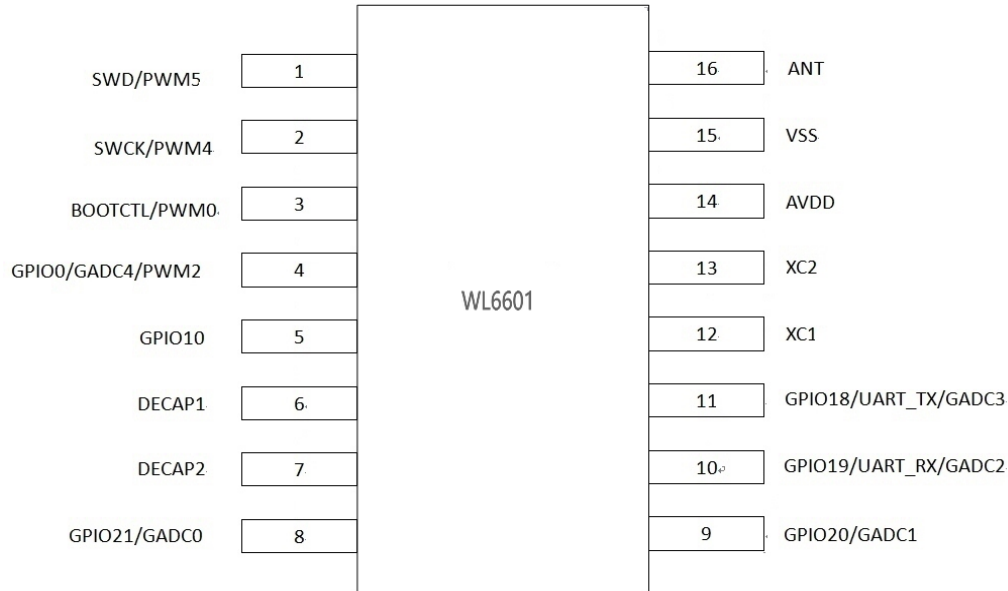

NO	Name	Description
1	SWD	SWI data/ General I/O/PWM5
2	SWCK	SWI clk/ General I/O/PWM4
3	BOOTCTL	Chip boot mode control/ General I/O/PWM0(PWM0 INVERTING can mux to pin1,2,4,5,8,9,10,11)
4	GPIO0	General I/O/ PWM2
5	GPIO10	General I/O/
6	DECAP1	The output of digital LDO, 100nF decap cap
7	DECAP2	The output of digital LDO, 1uF decap cap
8	GPIO21	General I/O/GADC input0/
9	GPIO20	General I/O/GADC input1/
10	GPIO19	General I/O/GADC input2/uart_rx
11	GPIO18	General I/O/GADC input3/uart_tx
12	XC1	The input of 32M crystal oscillator
13	XC2	The output of 32M crystal oscillator
14	AVDD	3V power supply
15	VSS	GND
16	ANT	The input of RF

Note: max 5 PWM, PIN1=PWM5,PIN2=PWM4,PIN4=PWM2. PWM0,1(wi INV) can mux to PIN3,5,8,9.

Only pin4 can be waked up by GPIO0.

4 Electrical Specifications

Name	Parameter(condition)	Min	Typ	Max	Unit	Com ment
Power Supplies						
HVIN	Voltage Input, typically 4.7uF decouple cap	3.1	5	5.5	V	(1)
HVOUT	Voltage Output, typically 1uF decouple cap, maximum 50mA load capability	2.4	2.9	3.3	V	
IQ_HV	Quiescent Current of high voltage LDO		600		nA	
AVDD	Voltage Input, typically 1uF decouple cap	1.7		3.6	V	(2)
AVDD	Voltage Input, typically 1uF decouple cap	1.7		3.6	V	
AVDD	Voltage Input	1.7		3.6	V	
VDDIO	Voltage Input	1.7		3.6	V	(3)
VDD	Voltage Output, typically 100nF decouple cap	1.1	1.2	1.3	V	
VDD	Voltage Output, typically 100nF decouple cap,	1.1	1.2	1.3	V	
Temperature						
TEMP	Temperature	-40		+125	°C	
Digital Input Pin						
VIH	High Level	VIO-0.3		VIO+0.3	V	
VIL	Low Level	VSS		VSS+0.3	V	
Digital Output Pin						
VOH	High Level	VIO-0.3		VIO+0.3	V	
VOL	Low Level	VSS		VSS+0.3	V	
Current Consumption						
IVDD	Retention mode (LPO, POR, alarm, I/O interrupts on), can be waked up by alarm & GPIO0~4		1		uA	(4)
IVDD	Retention mode (LPO, 128kB retention RAM, POR, sleep timer, I/O interrupts on), can be waked up by sleep timer & any GPIO		12		uA	
IVDD	RX mode, BLE , 100% on(wo DCDC @3V)		16		mA	(5)
IVDD	TX mode, BLE mode, 100% on(wo DCDC @3V)		17		mA	(6)
IVDD	Average Current, 500ms sniff, hold connection			32	uA	
Normal RF Condition						
FOP	Operating Frequency	2400		2480	Mhz	
FXTAL	Crystal Frequency	16	32			(7)
Transmitter Characteristics						
PRF	RF output power	-24	0	6	dBm	
CD	Carrier Drift Rate		5		kHz/50us	
PRF1	Out of band emission 2Mhz(GFSK)		-40		dBm	

PRF2	Out of band emission 3Mhz(GFSK)		-48		dBm	
BW	20dB bandwidth		0.9		Mhz	
PRF1	Out of band emission 2Mhz ($\pi/4$ DQPSK & 8PSK)		-30	-20		
PRF2	Out of band emission 3Mhz ($\pi/4$ DQPSK & 8PSK)		-42	-40		
Receiver Characteristics						
BT4.0 (BLE)						
SEN	High Gain mode, Sensitivity @0.1%		-94		dBm	
MaxIn	Maximum Input Power		5		dBm	
C/ICO	Co-channel C/I, Basic Rate, GFSK		7		dB	
C/I1ST	ACS C/I 1Mhz, Basic Rate, GFSK		5.5	7	dB	
C/I2ND	ACS C/I 2Mhz, Basic Rate, GFSK		-36	-34	dB	
C/I3RD	ACS C/I 3Mhz, Basic Rate, GFSK		-43		dB	
C/I1STI	ACS C/I image channel, Basic Rate, GFSK		-34		dB	
C/I2NDI	C/I 1 MHz adjacent to image channel, Basic Rate, GFSK		-28		dB	

- (1) HVIN & HVOUT are input & output of a high voltage LDO which is integrated, input voltage range from 3.1~5.5V, and maximum load capability up to 50mA. Typically used in Li_BAT(3.0~4.2V) or USB_Power(4.5~5.5V) applications. If input voltage is lower than 3.6V, HVIN & HVOUT should be left unconnected and should be powered by AVDD,VDDIO directly.
- (2) If RF output power should be larger than -4dBm, AVDD should be larger than 2.4V..
- (3) VDDIO should always be powered on in all working cycles..
- (4) By default, 128kB retention memory is on in retention mode, 64/96/128kB retention memory is supported.
- (5) Result based on standard gain mode.
- (6) Result based on 0dBm Pout.
- (7) 16M, 32M crystal supported, 32M by default.

5 Crystal Oscillator

The crystal oscillator requires a crystal with an accuracy of $\pm 40\text{ppm}$ as defined by the Bluetooth specification. Without external load capacitors are required to work with the crystal oscillator. The selection of the load capacitors is crystal dependent. The recommended crystal specification shows below.

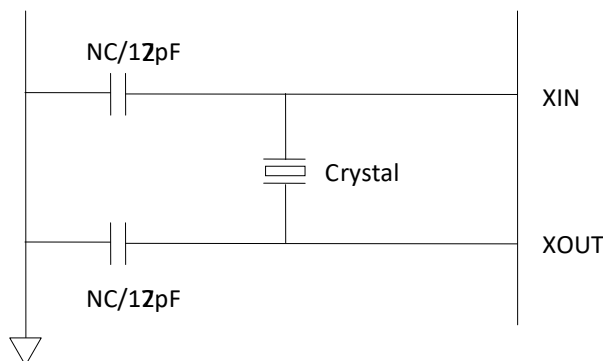

Recommended Oscillator Configuration – 12 pF Load Crystal

Reference Crystal Electrical Specifications

Name	Parameter (condition)	Min	Typ	Max	Unit	Comment
Frequency			32		Mhz	
Oscillation mode			Fundamental			
Frequency tolerance	@25°C		± 10	± 40	ppm	
Tolerance stability over temp	@0°C to @70°C		± 10	± 40	ppm	
Load capacitance			12		pF	
Operating temperature range		-40		+125	degree	
Drive level			100		uW	

6 Power consumption

W/O DC-DC	Parameter	Average Current	Unit
Sleep	/	1	uA
Sniff	500ms interval	32	uA
Discoverable	ADV interval:640ms Scan interval: 1280ms Scan window:11.25ms	137	uA

7 Bluetooth Security

7.1 Pairing

- Pin Code

7.2 Security Simple Pairing

- Jut Work(No input)
- Keyboard
- DisplayYesNo

8 MFi

Support Apple's MFi authentication and iAP1/iAP2 protocols.

9 Bluetooth Stack

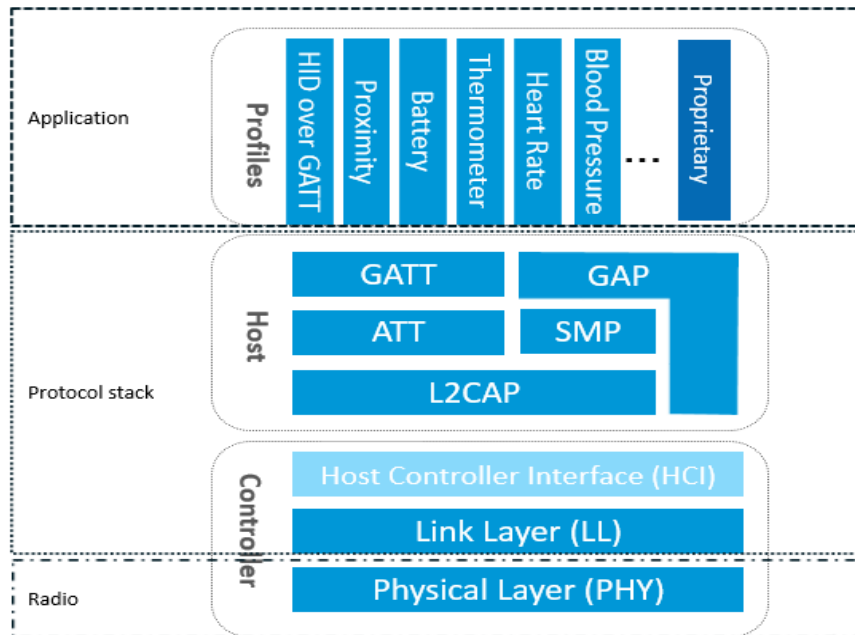

10.1 Application Schematic(WL6603-QFN32)

(1.8~3.6V)

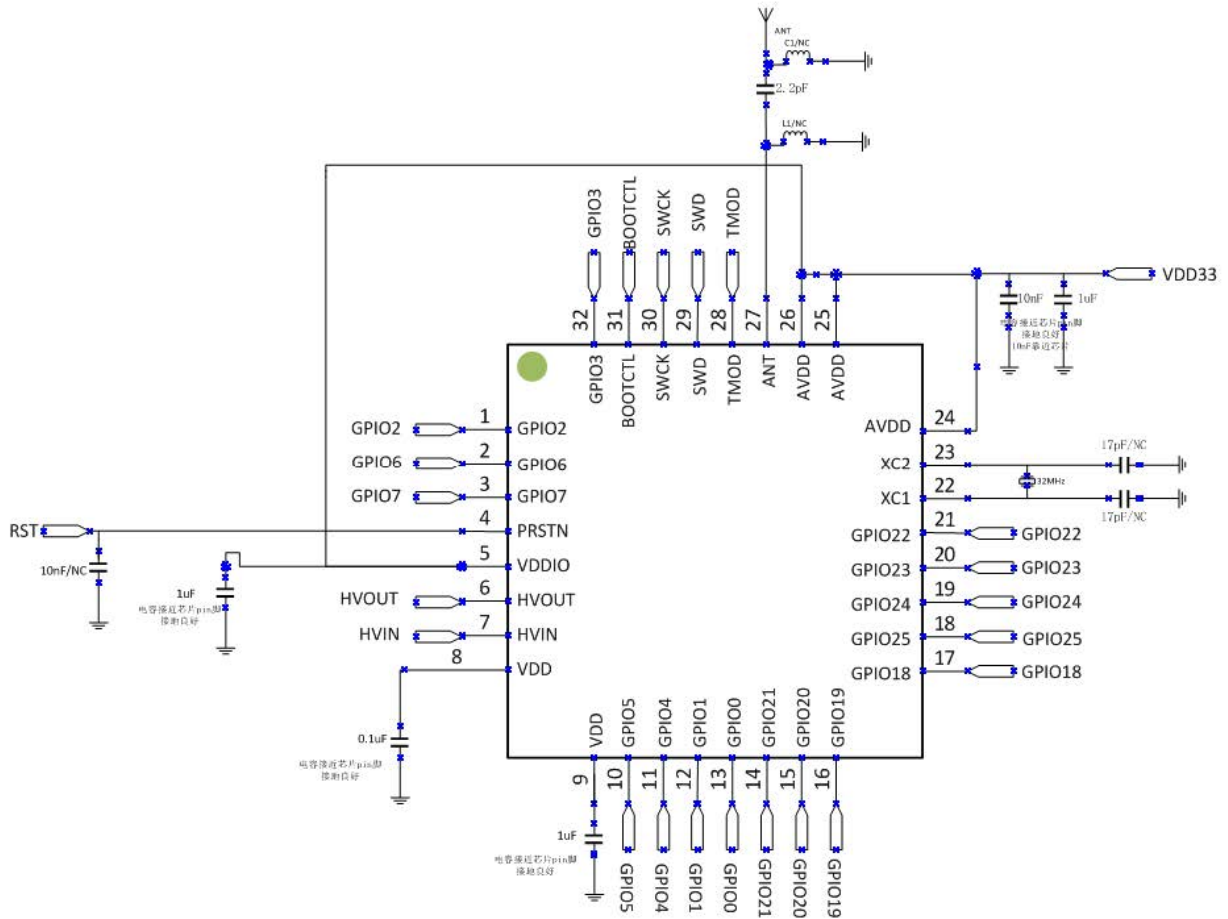

(3.1~5.5V)

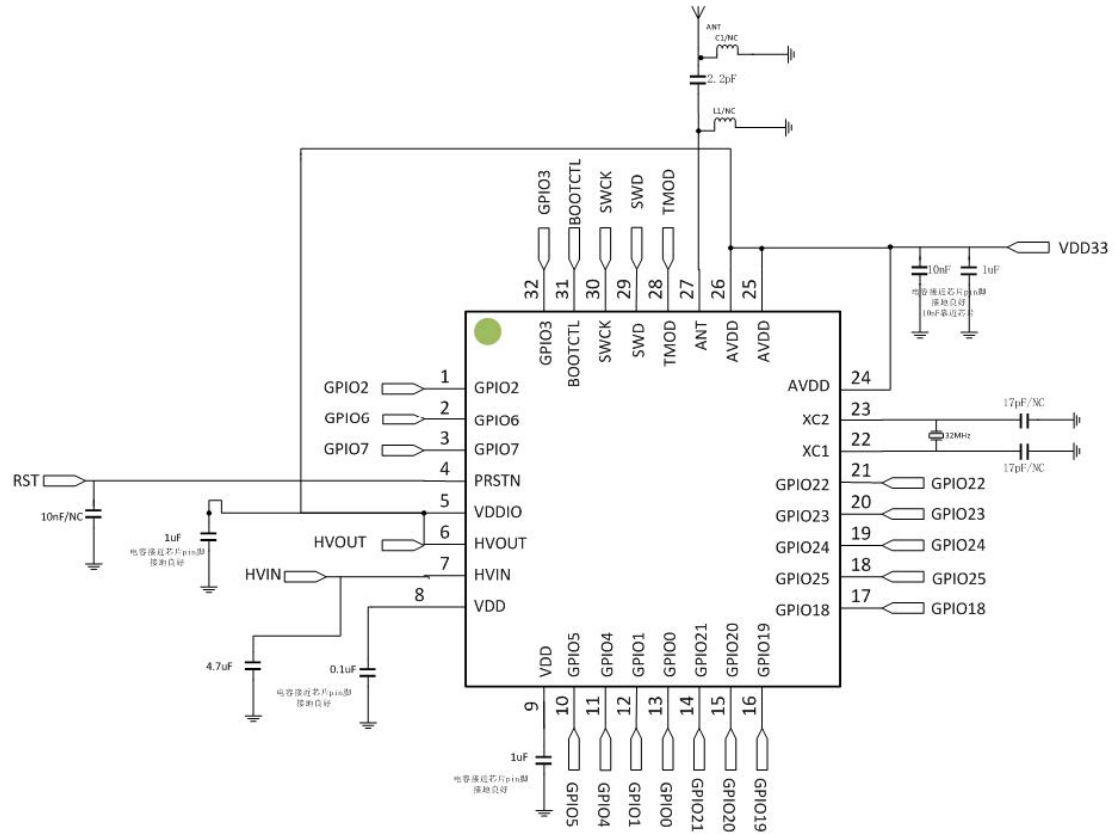

10.2 Application Schematic(WL6602 SSOP16)

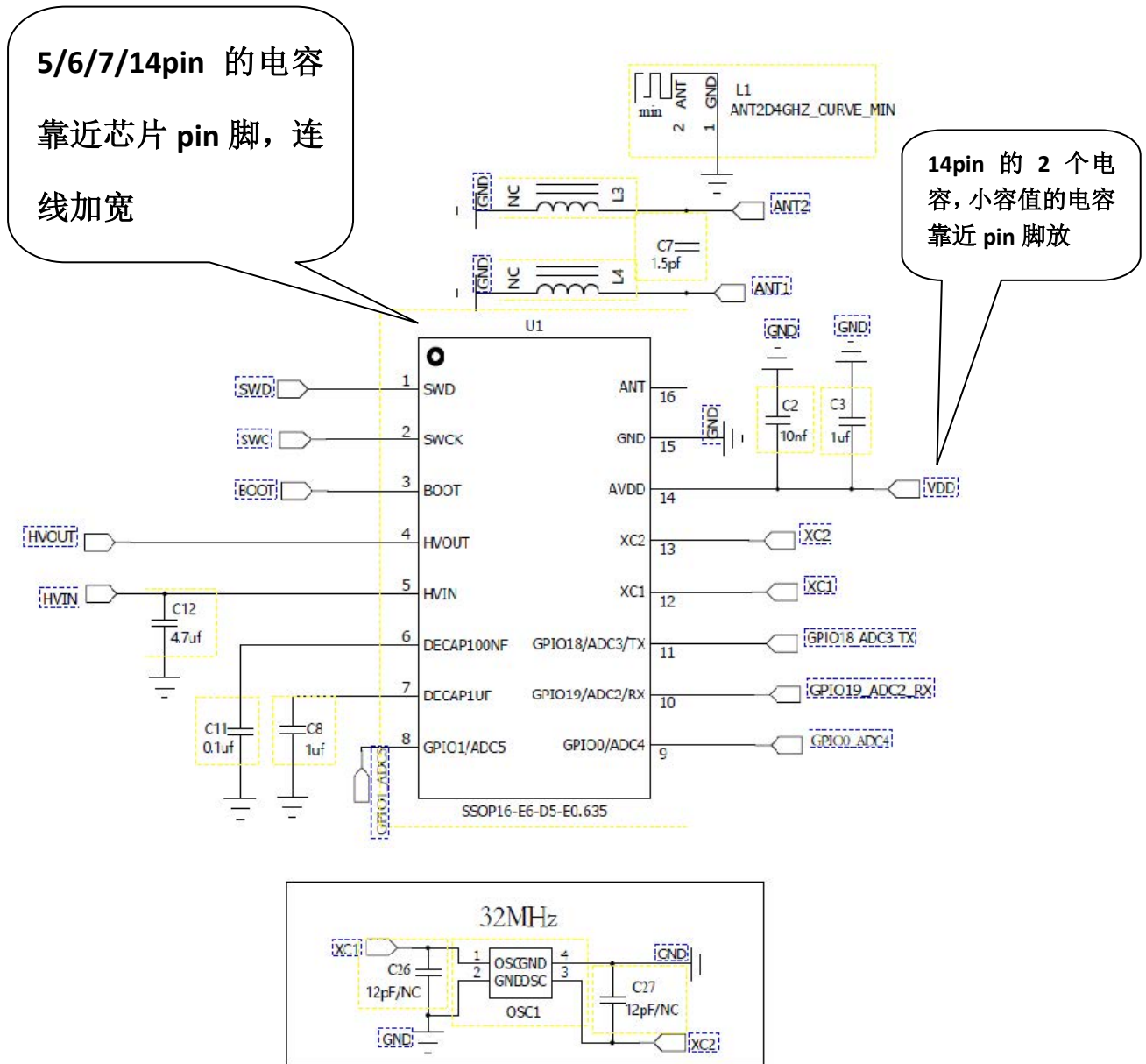

Note: c7=2.2pF.

if use 1.8~3.6V input, connect to pin14, pin4,5 NC, c12 NC.

if use 3.1~5.5V input, connect to pin5, pin4 connect to pin14.

10.3 Application Schematic(WL6601 SOP16)

6/7/14pin 的电容靠近芯片 pin 脚，连线加宽

14pin 的 2 个电容，小容值的电容靠近 pin 脚放

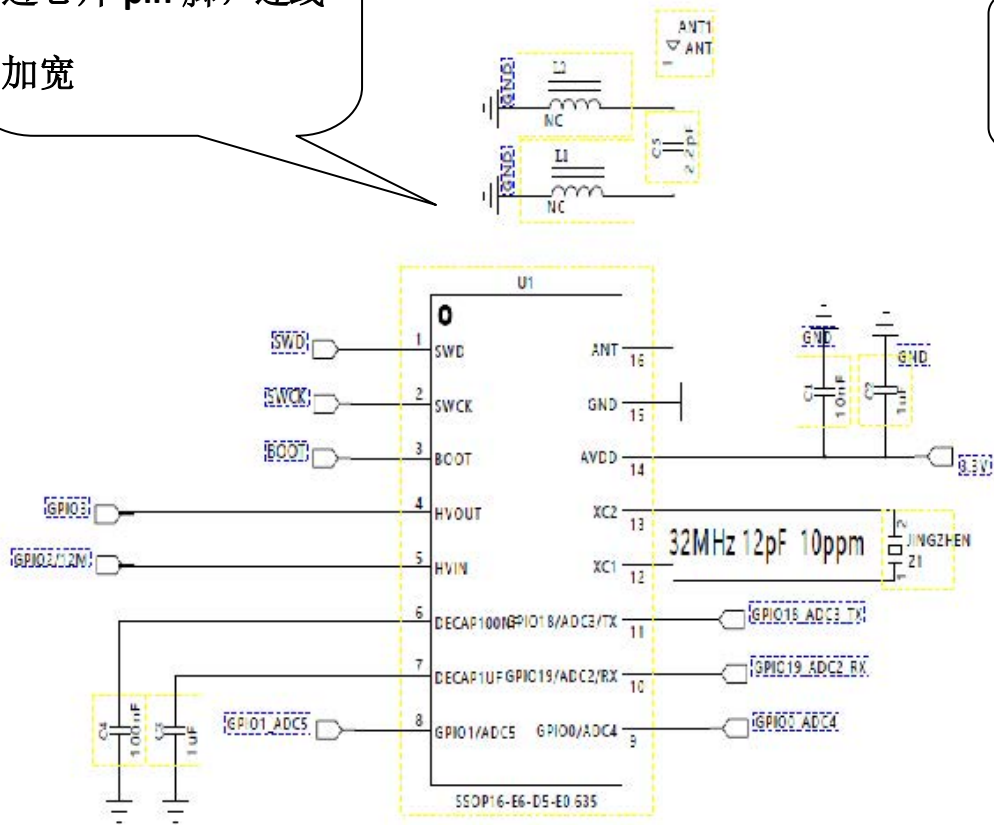

11.1 Package Information(QFN32)

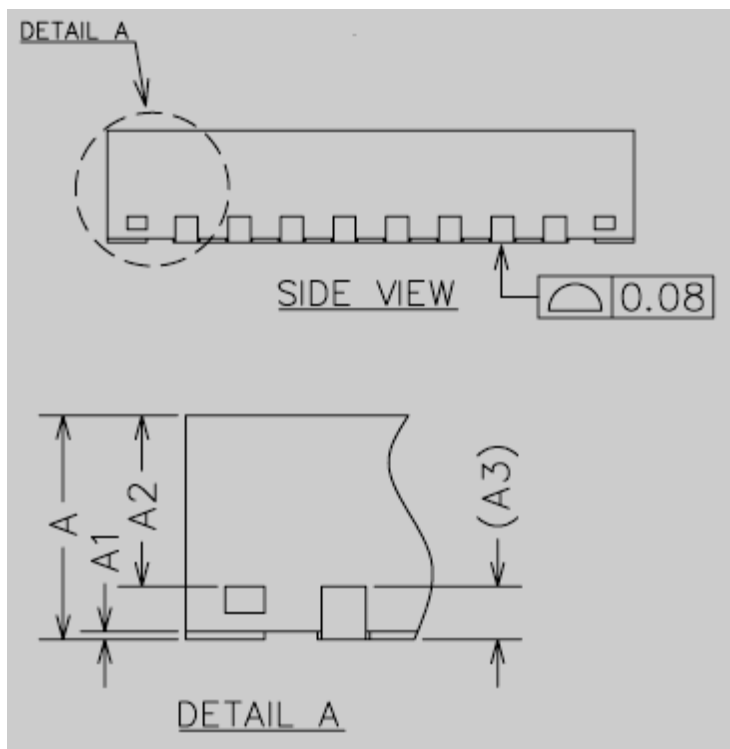
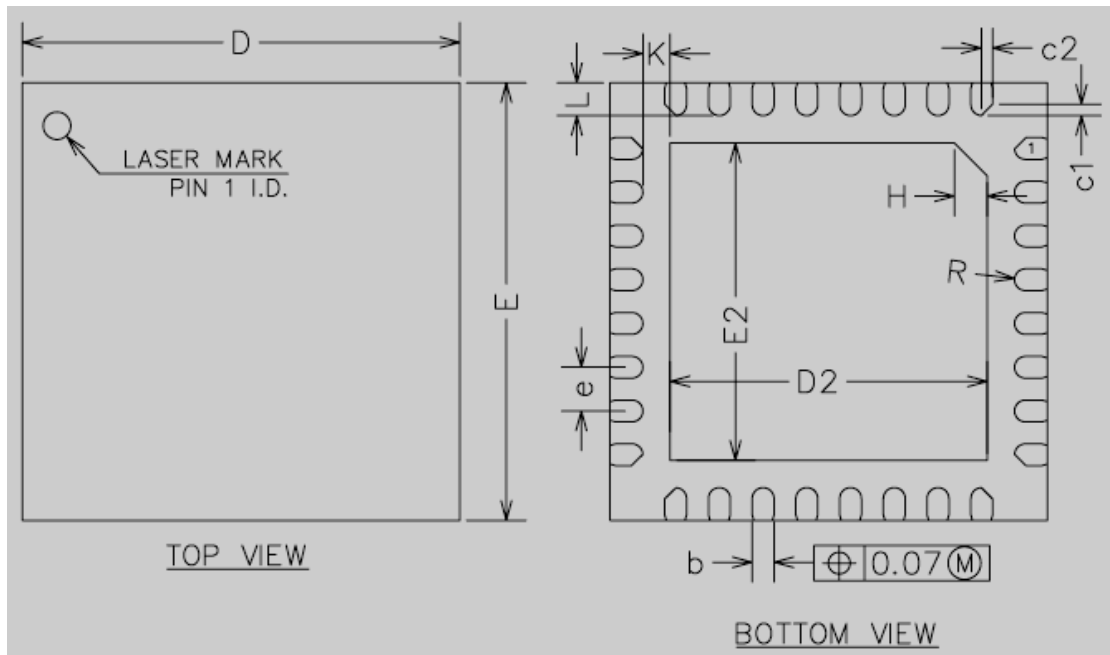

COMMON DIMENSIONS
(UNITS OF MEASURE=MILLIMETER)

SYMBOL	MIN	NOM	MAX
A	0.80	0.85	0.90
A1	0	0.02	0.05
A2	0.60	0.65	0.70
A3	0.20REF		
b	0.15	0.20	0.25
D	3.90	4.00	4.10
E	3.90	4.00	4.10
D2	2.80	2.90	3.00
E2	2.80	2.90	3.00
e	0.30	0.40	0.50
H	0.30REF		
K	0.25REF		
L	0.25	0.30	0.35
R	0.09	—	—
c1	—	0.10	—
c2	—	0.10	—

11.2 Package Information(SSOP16)

SSOP16:

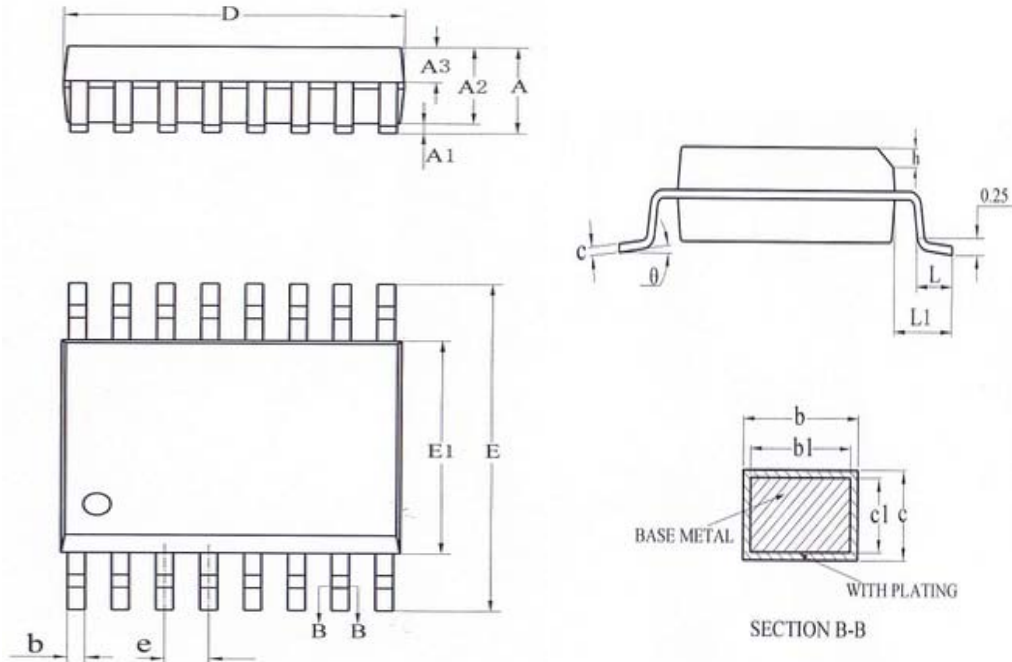

SYMBOL	MILLIMETER		
	MIN	NOM	MAX
A	—	—	1.75
A1	0.10	—	0.225
A2	1.30	1.40	1.50
A3	0.55	0.60	0.65
b	0.23	—	0.31
b1	0.22	0.25	0.28
c	0.20	—	0.24
c1	0.19	0.20	0.21
D	4.80	4.90	5.00
E	5.80	6.00	6.20
E1	3.80	3.90	4.00
e	0.635BSC		
h	0.25	—	0.50
L	0.50	0.65	0.80
L1	1.05REF		
θ	0	—	8°

11.3 Package Information(SOP16)

SOP16:

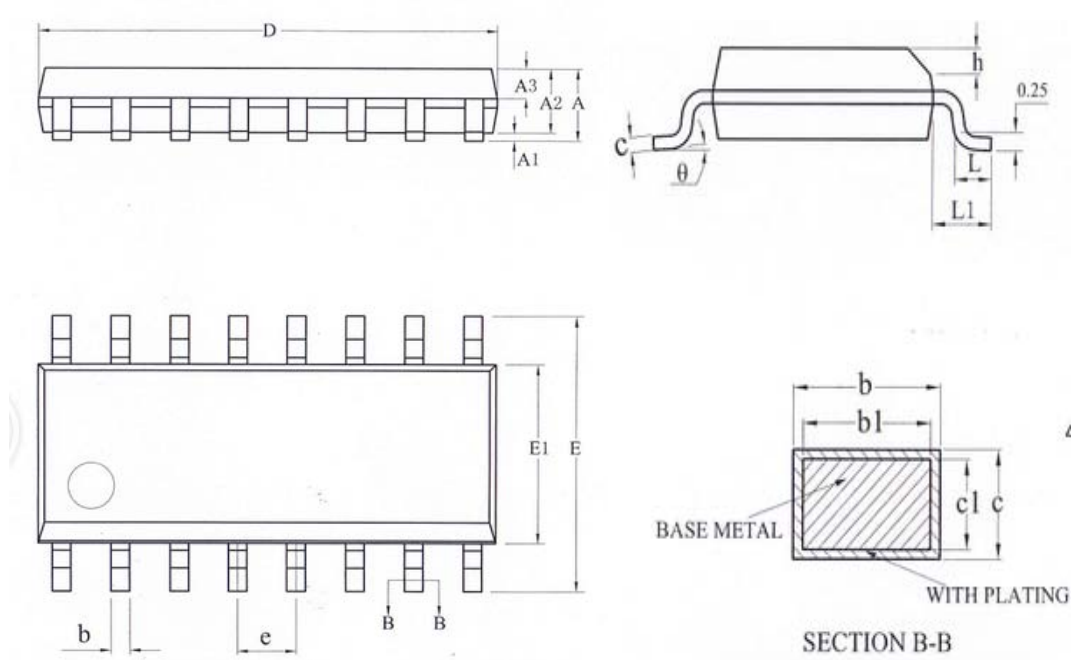

SYMBOL	MILLIMETER		
	MIN	NOM	MAX
A	—	—	1.75
A1	0.10	—	0.225
A2	1.30	1.40	1.50
A3	0.60	0.65	0.70
b	0.39	—	0.47
b1	0.38	0.41	0.44
c	0.20	—	0.24
c1	0.19	0.20	0.21
D	9.80	9.90	10.00
E	5.80	6.00	6.20
E1	3.80	3.90	4.00
e	1.27BSC		
h	0.25	—	0.50
L	0.50	—	0.80
L1	1.05REF		
θ	0	—	8°

12 Order Information

Part number	Package	Packing	Minimum Order Quantity
WL6603	QFN 4mmx4mm 32-Pin	Tape Reel	10K
WL6602	SSOP16		
WL6601	SOP16		

Revision History

Rev.	Date	Author(s)	Remark
1.0	2020-5-10	rilly	
1.1	2020-5-11	rilly	WL6602 pin
1.2	2020-5-12	rilly	WL6602 pin, deep sleep mode
1.3	2020-5-20	rilly	
1.4	2020-5-22	rilly	