

Features

- Low Power Consumption: 70uA (Typ)
- Maximum Output Current: 300mA
- Small Dropout Voltage
130mV@100mA (Vout=3.3V)
- PSRR=70dB@1KHz
- Input Voltage Range: 2.0V~6.5V
- Output Voltage Range: 1.2V~3.6V
(customized on command in 0.1V steps)
- Standby Current : less than 1μA
- High Accurate: ±2%
- Good Transient Response
- Over-Temperature Protection
- Support Fixed Output Voltage
- Output Current Limit
- Stable with Ceramic Capacitor
- Available Package
SOT23-3 \ SOT23-5 \ SOT89-3 \ SC70-5
- RoHS Compliant and Lead (Pb) Free

Application

- Portable, Battery Powered Equipment
- Audio/Video Equipment
- Power Management of MP3. PDA.....
- Weighting Scales. Home Automation

Description

The WL9003 series are highly precise, low noise, positive voltage LDO regulators manufactured using CMOS processes. The series achieves high ripple rejection and low dropout and consists of a standard voltage source, an error correction, current limiter and a phase compensation circuit plus a driver transistor. Output voltage is selectable in 0.1V increments within a range of 1.2V ~ 3.6V. The series is also compatible with low ESR ceramic capacitors which give added output stability. This stability can be maintained even during load fluctuations due to the excellent transient response of the series. The limiter's feedback circuit also operates as a protect for the output current limiter The CE function enables the output to be turned off, resulting in greatly reduced power consumption. The WL9003 consumes less than 1μA in shutdown mode and has fast turn-on time less than 50s. The other features include ultra low dropout voltage, high output accuracy, current limiting protection, and high ripple rejection ratio.

Application Circuits

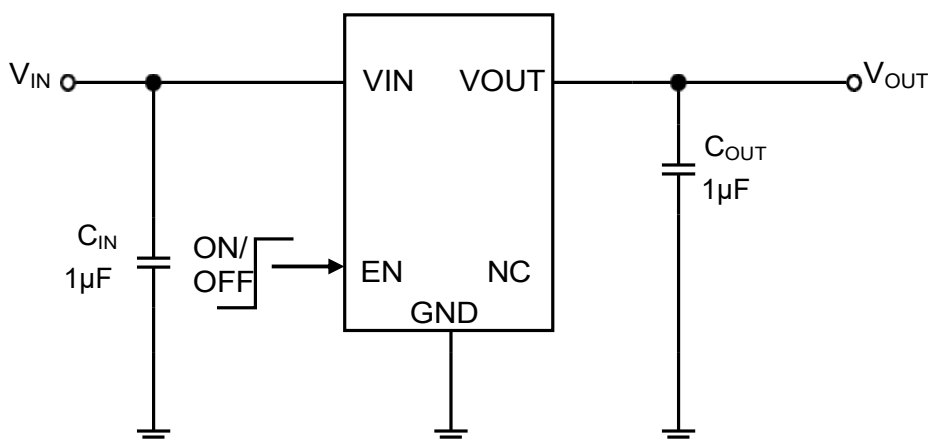

Pin Configuration

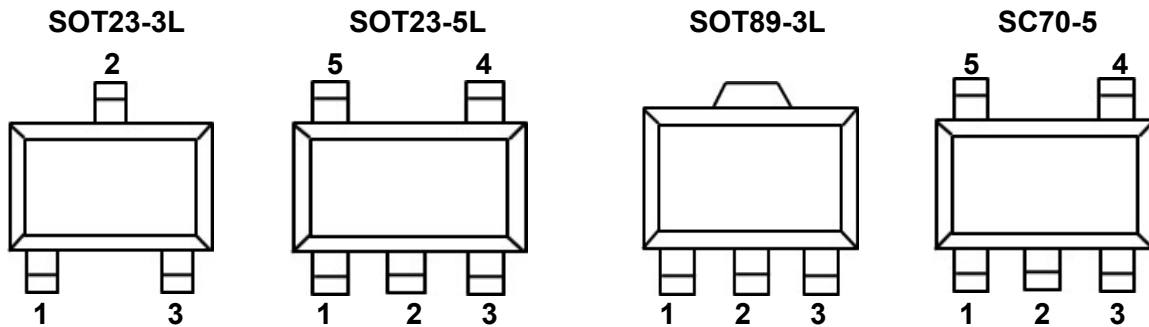

Pin Description

Pin No.				Pin Name	Pin Function
SOT23-3L	SOT23-5L	SOT89-3L	SC70-5		
2	1	2	1	VIN	Supply voltage input.
1	2	1	2	GND	Ground.
-----	3	-----	3	CE	Chip Enable
-----	4	-----	4	NC	No Internal Connection.
3	5	3	5	VOUT	Voltage Output.

Order Information

WL9003①②-③④

Designator	Symbol	Description
①②	S3/S5/P3/K5	SOT23-3L / SOT23-5L / SOT89-3L / SC70-5
③④	Integer	Output Voltage (12、15、18、25、28、30、33、36)

Model	Marking**	Description	Package	T/R Qty
WL9003S3-XX*	①②③④	WL9003 300mA Low-Dropout Linear voltage regulator	SOT23-3L	3,000 PCS
WL9003S5-XX*			SOT23-5L	3,000 PCS
WL9003P3-XX*	①②③④		SOT89-3L	1,000 PCS
WL9003K5-XX*			SC70-5	3,000 PCS

Note: (*) XX Represents the Output Voltage

(**) Please Page 3 . ①②③④ Only Off SOT23-3L SOT89-3L

Marking Information

①②Represents the product name

Mark ①②	Product Series
AW	WL9003 S3 / P3

③Represents the range of output voltage

Mark ③		Product Series
VOUT: 1.0V-3.0V	VOUT: 3.1V-5.0V	WL9003 S3 / P3
V	E	

④Represents the Output Voltage

Mark④	Output Voltage(V)				Mark④	Output Voltage(V)			
0	-	3.1	-	-	F	1.6	4.6	-	-
1	-	3.2	-	-	H	1.7	4.7	-	-
2	-	3.3	-	-	K	1.8	4.8	-	-
3	-	3.4	-	-	L	1.9	4.9	-	-
4	-	3.5	-	-	M	2.0	5.0	-	-
5	-	3.6	-	-	N	2.1	-	-	-
6	-	3.7	-	-	P	2.2	-	-	-
7	-	3.8	-	-	R	2.3	-	-	--
8	-	3.9	-	-	S	2.4	-	-	-
9	1.0	4.0	-	-	T	2.5	-	-	-
A	1.1	4.1	-	-	U	2.6	-	-	-
B	1.2	4.2	-	-	V	2.7	-	-	-
C	1.3	4.3	-	-	X	2.8	-	-	-
D	1.4	4.4	-	-	Y	2.9	-	-	-
E	1.5	4.5	-	-	Z	3.0	-	-	-

Model	V _{OUT} (V)	Mark	Model	V _{OUT} (V)	Mark
WL9003S5-12	1.2	DA=G3K	WL9003K5-12	1.2	A1w2
WL9003S5-15	1.5	DS=J2T	WL9003K5-15	1.5	A1w5
WL9003S5-18	1.8	DC=E2H	WL9003K5-18	1.8	A1w8
WL9003S5-25	2.5	DH=M6C	WL9003K5-25	2.5	A2w5
WL9003S5-28	2.8	DJ=N10	WL9003K5-28	2.8	A2w8
WL9003S5-30	3.0	DK=06L	WL9003K5-30	3.0	A3w0
WL9003S5-33	3.3	DE=A1D	WL9003K5-33	3.3	A3w3
WL9003S5-36	3.6	DF=C2D	WL9003K5-36	3.6	A3w6

Absolute Maximum Ratings ^{(1) (2)}

Parameter		Symbol	Maximum Rating	Unit
Input Voltage		V _{IN}	V _{SS} -0.3~V _{SS} +7.0	V
		V _{ON/OFF}	V _{SS} -0.3~V _{IN} +0.3	V
Output Current		I _{OUT}	450	mA
Output Voltage		V _{OUT}	V _{SS} -0.3~V _{IN} +0.3	V
Power Dissipation	SOT23-3	P _d	300	mW
	SOT23-5		250	
	SOT89-3		400	
	SC70-5		300	
Thermal Resistance	SOT23-3	R _{θJA} ⁽³⁾ (Junction-to-ambient thermal resistance)	330	°C/W
	SOT23-5		400	°C/W
	SOT89-3		250	°C/W
	SC70-5		330	°C/W
Operating Temperature		T _{opr}	-40~85	°C
Storage Temperature		T _{stg}	-40~125	°C
Soldering Temperature & Time		T _{solder}	260°C, 10s	

Note (1): Exceeding these ratings may damage the device.

Note (2): The device is not guaranteed to function outside of its operating conditions

Note (3): The package thermal impedance is calculated in accordance to JESD 51-7.

ESD Ratings

Item	Description	Value	Unit
V _(ESD-HBM)	Human Body Model (HBM) ANSI/ESDA/JEDEC JS-001-2014 Classification, Class: 2	±4000	V
V _(ESD-CDM)	Charged Device Mode (CDM) ANSI/ESDA/JEDEC JS-002-2014 Classification, Class: C0b	±400	V
I _{LATCH-UP}	JEDEC STANDARD NO.78E APRIL 2016 Temperature Classification, Class: I	±200	mA

ESD testing is performed according to the respective JESD22 JEDEC standard. The human body model is a 100 pF capacitor discharged through a 1.5kΩ resistor into each pin. The machine model is a 200pF capacitor discharged directly into each pin.

Recommended Operating Conditions

Parameter	MIN.	MAX.	Units
Supply voltage at V _{IN}	2.0	6.5	V
Operating junction temperature range, T _j	-40	125	°C
Operating free air temperature range, T _A	-40	85	°C

Note : All limits specified at room temperature (T_A = 25°C) unless otherwise specified. All room temperature limits are 100% production tested. All limits at temperature extremes are ensured through correlation using standard Statistical Quality Control (SQC) methods. All limits are used to calculate Average Outgoing Quality Level (AOQL).

Electrical Characteristics

(Test Conditions: $V_{IN}=4.3V$, $V_{OUT}=3.3V$, $C_{IN}=1\mu F$, $C_{OUT}=1\mu F$, $T_A=25^\circ C$, unless otherwise specified.)

Parameter	Symbol	Conditions	Min	Typ	Max	Units
Input Voltage	V_{IN}		-0.3		6.5	V
Quiescent Current	I_Q	$V_{IN} > V_{OUT}$, $EN=V_{IN}$ $I_{LOAD}=0mA$	—	70	—	μA
Standby Current	I_{STBY}	$V_{EN}=GND$, shutdown	—	1	—	μA
Output Voltage	V_{OUT}	$V_{IN}=V_{set}+1.0V$ $I_{OUT}=40mA$	$V_{set} \cdot 0.98$	V_{set}	$V_{set} \cdot 1.02$	V
Maximum Output Current	$I_{OUT(Max)}$	$V_{IN}=V_{OUT}+1.0V$	—	300	—	mA
Dropout Voltage	V_{DROP}	$I_{OUT}=100mA$		130		mV
		$I_{OUT}=200mA$		250		
Line Regulation	$\frac{\Delta V_{OUT}}{\Delta V_{IN} \cdot V_{OUT}}$	$I_{OUT}=40mA$ $(V_{set}+1.0V) \leq V_{IN} \leq 7.0V$		0.05		%/V
Load Regulation	ΔV_{OUT}	$V_{IN}=V_{set}+1.0V$ $1mA \leq I_{OUT} \leq 100mA$		50		mV
Short Current	I_{SHORT}	$R_L=1\Omega$		50		mA
Current Limit	I_{LIMIT}	$V_{IN}=V_{set}+1.0V$	—	450	—	mA
Power Supply Rejection Rate	PSRR	$V_{IN}=V_{set}+1.0V$ $f=1KHz, I_{OUT}=40mA$	—	70	—	dB
EN Threshold Voltage	V_{IL}	$V_{IN}=3V \sim 5.5V$, Shutdown			0.4	
	V_{IH}	$V_{IN}=3V \sim 5.5V$, Start-Up	1.1			
Output Noise Voltage	V_{ON}	$I_{OUT}=40mA$ $BW = 300Hz \sim 50kHz$		50		μV_{RMS}
Output Voltage Temperature Coefficient	$\frac{\Delta V_{OUT}}{\Delta T \cdot V_{OUT}}$	$I_{OUT}=10mA$	—	100	—	ppm/ $^\circ C$

Function Block Diagram

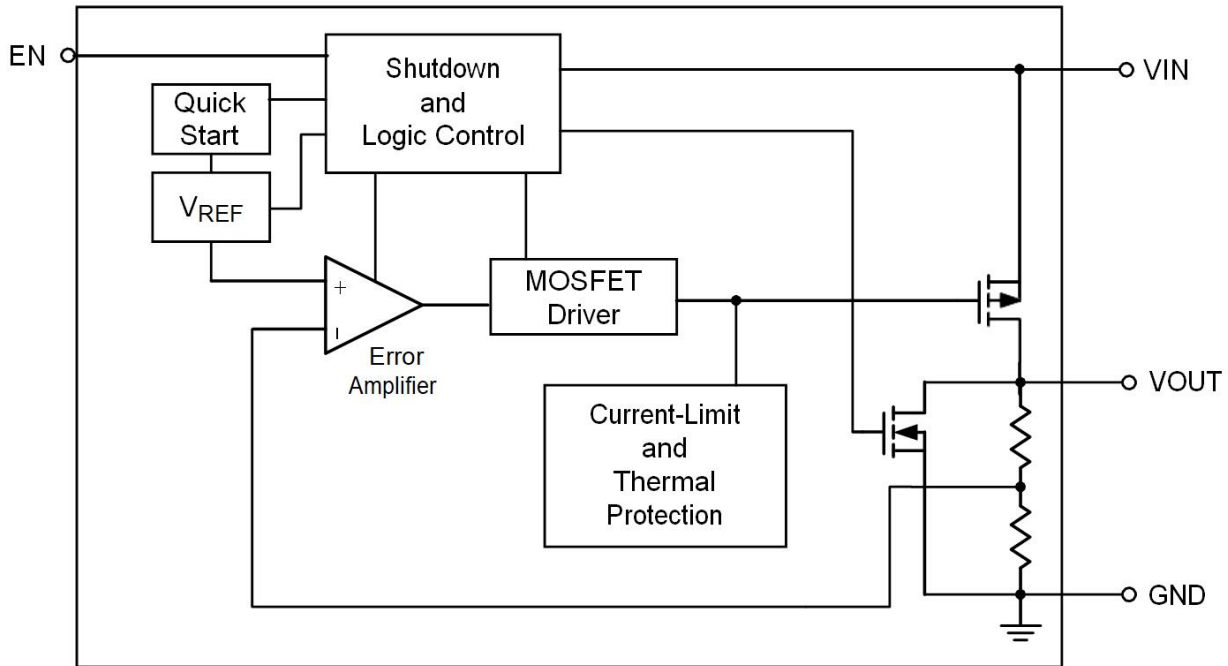

Application Guideline

Input Capacitor

A 1 μ F ceramic capacitor is recommended to connect between V_{DD} and GND pins to decouple input power supply glitch and noise. The amount of the capacitance may be increased without limit. This input capacitor must be located as close as possible to the device to assure input stability and less noise. For PCB layout, a wide copper trace is required for both VIN and GND.

Output Capacitor

An output capacitor is required for the stability of the LDO. The recommended output capacitance is 1 μ F, ceramic capacitor is recommended, and temperature characteristics are X7R or X5R. Higher capacitance values help to improve load/line transient response. The output capacitance may be increased to keep low undershoot/overshoot. Place output capacitor as close as possible to VOUT and GND pins.

Dropout Voltage

The dropout voltage refers to the voltage difference between the VIN and VOUT pins while operating at specific output current. The dropout voltage V_{DROP} also can be expressed as the voltage drop on

the pass-FET at specific output current (I_{RATED}) while the pass-FET is fully operating at ohmic region and the pass-FET can be characterized as a resistance $R_{DS(ON)}$. Thus the dropout voltage can be defined as ($V_{DROP} = V_{IN} - V_{OUT} = R_{DS(ON)} \times I_{RATED}$). For normal operation, the suggested LDO operating range is ($V_{IN} > V_{OUT} + V_{DROP}$) for good transient response and PSRR ability. Vice versa, while operating at the ohmic region will degrade the performance severely.

Thermal Application

For continuous operation, do not exceed the absolute maximum junction temperature. The maximum power dissipation depends on the thermal resistance of the IC package, PCB layout, rate of surrounding airflow, and difference between junction and ambient temperature. The maximum power dissipation can be calculated as below: $T_A = 25^\circ\text{C}$, PCB,

The max PD = $(125^\circ\text{C} - 25^\circ\text{C}) / (\text{Thermal Resistance } ^\circ\text{C/W})$

Power dissipation (PD) is equal to the product of the output current and the voltage drop across the output pass element, as shown in the equation below:

$$PD = (V_{IN} - V_{OUT}) \times I_{OUT}$$

Layout Consideration

By placing input and output capacitors on the same side of the PCB as the LDO, and placing them as close as is practical to the package can achieve the best performance. The ground connections for input and output capacitors must be back to the WL9003 ground pin using as wide and as short of a copper trace as is practical. Connections using long trace lengths, narrow trace widths, and/or connections through via must be avoided. These add parasitic inductances and resistance that results in worse performance especially during transient conditions.

Packaging Information

SOT23-3L

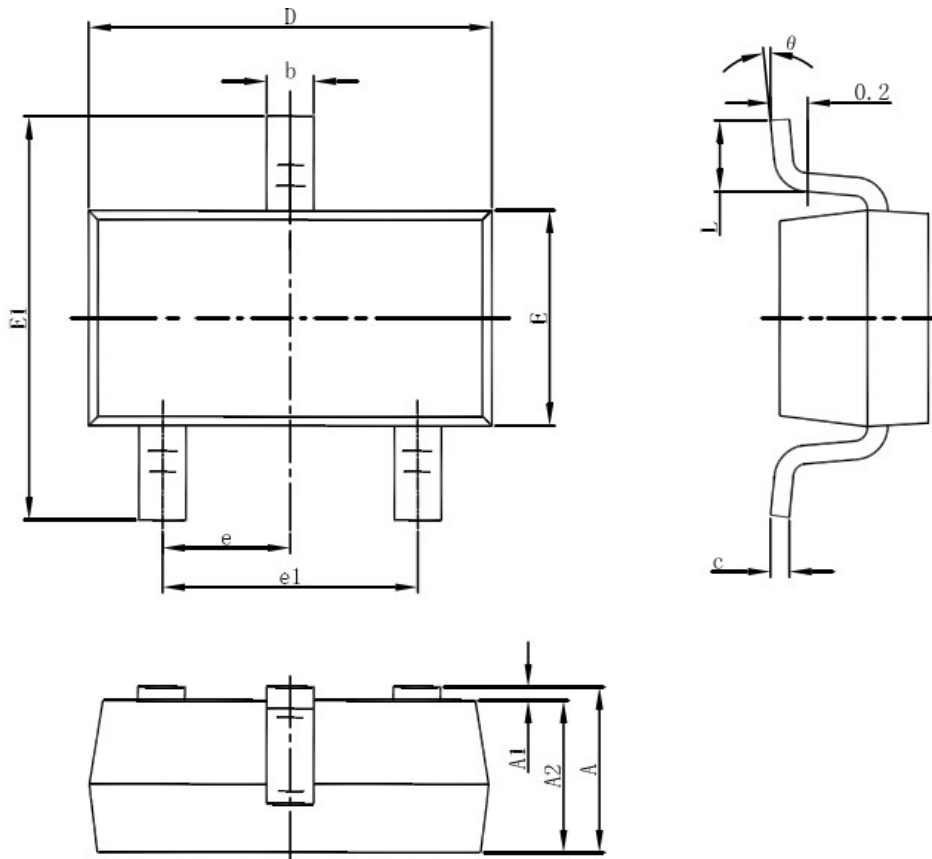

Symbol	Dimensions In Millimeters		Dimensions In Inches	
	Min	Max	Min	Max
A	1.050	1.250	0.041	0.049
A1	0.000	0.100	0.000	0.004
A2	1.050	1.150	0.041	0.045
b	0.300	0.500	0.012	0.020
c	0.100	0.200	0.004	0.008
D	2.820	3.020	0.111	0.119
E	1.500	1.700	0.059	0.067
E1	2.650	2.950	0.104	0.116
e	0.950(BSC)		0.037(BSC)	
e1	1.800	2.000	0.071	0.079
L	0.300	0.600	0.012	0.024
θ	0°	8°	0°	8°

Packaging Information

SOT89-3L

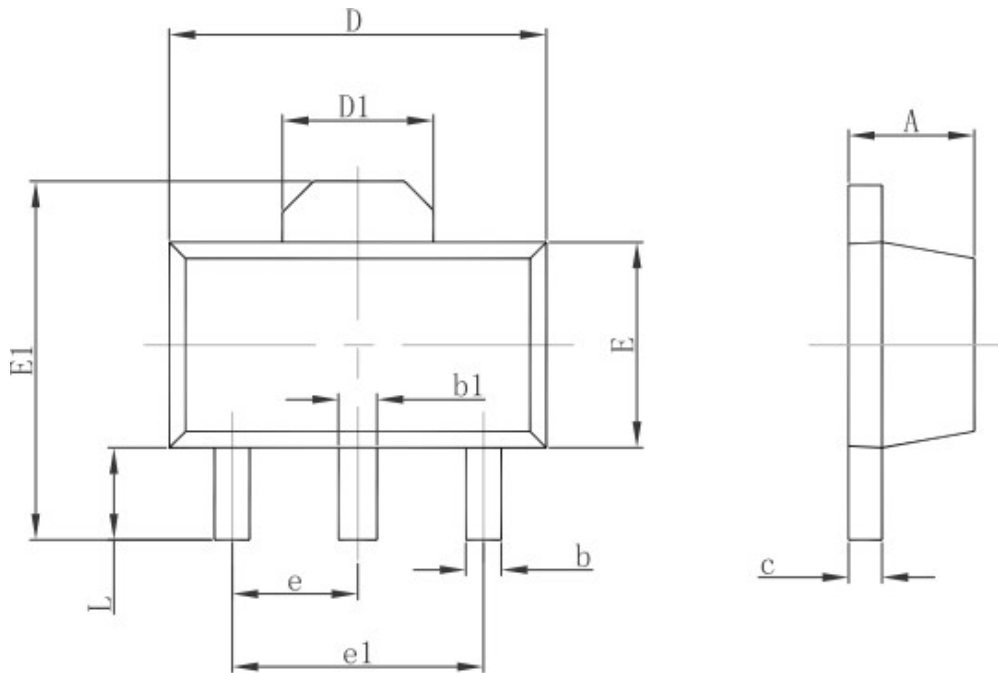

Symbol	Dimensions In Millimeters		Dimensions In Inches	
	Min.	Max.	Min.	Max.
A	1.400	1.600	0.055	0.063
b	0.320	0.520	0.013	0.020
b1	0.400	0.580	0.016	0.023
c	0.350	0.440	0.014	0.017
D	4.400	4.600	0.173	0.181
D1	1.550 REF.		0.061 REF.	
E	2.300	2.600	0.091	0.102
E1	3.940	4.250	0.155	0.167
e	1.500 TYP.		0.060 TYP.	
e1	3.000 TYP.		0.118 TYP.	
L	0.900	1.200	0.035	0.047

Packaging Information

SOT23-5L

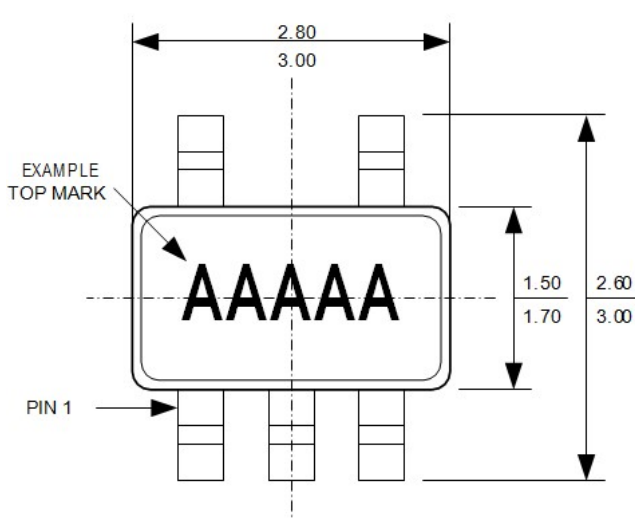

TOP VIEW

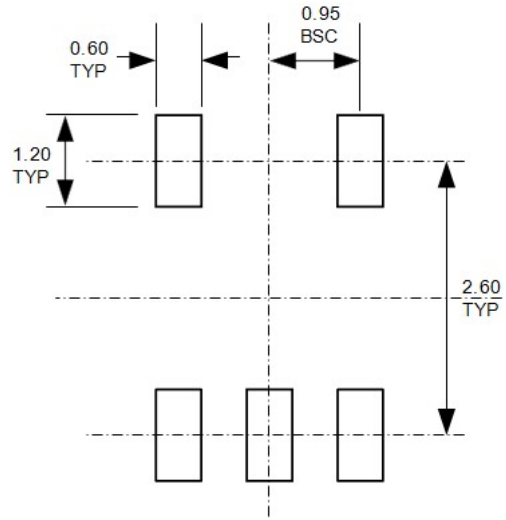

RECOMMENDED PAD LAYOUT

TOP VIEW

RECOMMENDED PAD LAYOUT

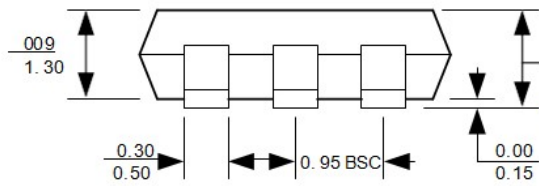

FRONT VIEW

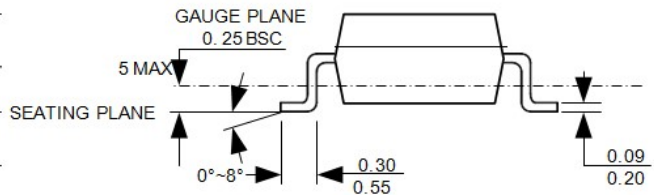

SIDE VIEW

Packaging Information

SC70-5

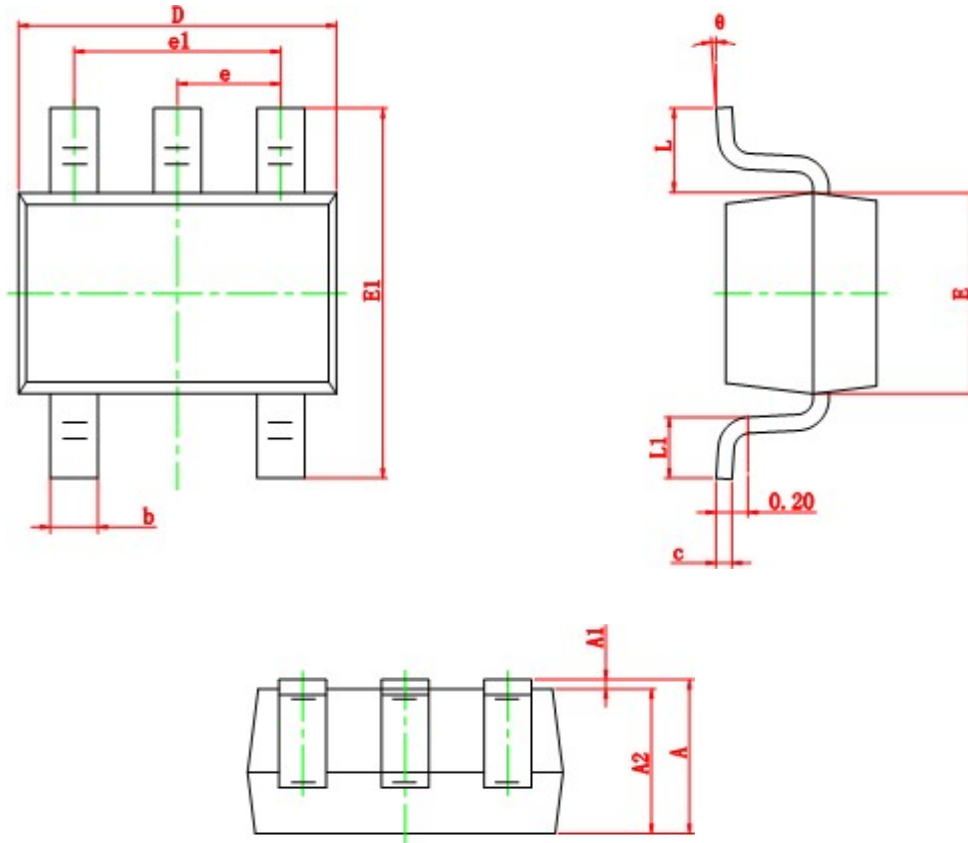

Symbol	Dimensions In Millimeters		Dimensions In Inches	
	Min	Max	Min	Max
A	0.900	1.100	0.035	0.043
A1	0.000	0.100	0.000	0.004
A2	0.900	1.000	0.035	0.039
b	0.150	0.350	0.006	0.014
c	0.080	0.150	0.003	0.006
D	2.000	2.200	0.079	0.087
E	1.150	1.350	0.045	0.053
E1	2.150	2.450	0.085	0.096
e	0.650 TYP		0.026 TYP	
e1	1.200	1.400	0.047	0.055
L	0.525 REF		0.021 REF	
L1	0.260	0.460	0.010	0.018
θ	0°	8°	0°	8°