

Two-circuit Limit Switch

WL

Wide Selection of Two-circuit Limit Switches

- A wide selection of models are available, including the overtravel models with greater OT, lamp-equipped models for checking operation, low-temperature and heat-resistant models, and microload models.
- Microload models are added to the product lineup.
- Meets EN/IEC standards (only Switches with ground terminals).
- Switches with ground terminals have the CE marking.



Approved Standards

Agency	Standard	File No.
UL	UL508	E76675
CSA	CSA C22.2 No. 14	LR45746
TÜV	EN60947-5-1	R9551016

Note: Contact your OMRON representative for more information on approved models.

Ordering Information

Classification

Specifications		Standard	Overtravel	High-precision	Features	Page
Actuators	Roller lever	Yes	Yes	Yes	Five models: Roller lever, adjustable roller lever, adjustable rod lever, fork lever lock, rod spring lever.	42 to 56
	Plunger	Yes	---	---	Six models: Top plunger, top-roller plunger, top-ball plunger, horizontal plunger, horizontal-roller plunger, horizontal-ball plunger.	
	Flexible rod	Yes	---	---	Two models: coil spring and steel wire.	
Load/contact	Standard load	SPST-NO/ SPST-NC type	Yes		Standard models use a two-circuit double-break switch.	
	Microload	SPST-NO/ SPST-NC type	Yes		Specifications include gold-plated contacts.	

Specifications			Standard	Overtravel	High-precision	Features	Page	
Environment-resistant models (See note 3.)	Airtight-seal	WL□-55	Yes (Cannot be used with heat-resistant and low-temperature models.)			Uses an airtight-sealed built-in switch.	60	
	Hermetic seal	Molded terminals				WL□-139		Lead wires are attached. The case cover and conduit section are molded from epoxy resin to improve sealing performance.
						WL□-140 WL□-141		Lead wires are attached. The case is filled with epoxy resin, to ensure high sealing performance. The Head opening is protected from cutting powder. (WL□-141) Only WLG2, WLC A2, and WLGCA2 can be fabricated. (WL□-141 models.)
		Anti-coolant				WL□-RP60		Lead wires are attached. The case is filled with epoxy resin, to ensure high sealing performance. To improve the anti-coolant properties (water-soluble coolant), rubber with high chemical-resistance has been used.
	Spatter-prevention	WL□-S				Yes		To improve spatter prevention during welding, a heat-resistant resin is used, and screws and rollers are all made from stainless steel.
Heat-resistant	WL□-TH	Yes (Cannot be used with airtight, hermetic, low-temperature, corrosion-proof, or lamp-equipped models.)			To improve heat resistance, silicone rubber is used for rubber parts and for the built-in switch. The operating temperature range is +5°C to 120°C.	60		
Low-temperature	WL□-TC	Yes (Cannot be used with airtight, hermetic, heat-resistant, corrosion-proof, or lamp-equipped models.)			To improve low temperature resistance, silicone rubber is used. The operating temperature range is -40°C to 40°C.			
Corrosion-proof (See note 4.)	WL□-RP	Yes (Cannot be used with lamp-equipped models.)			Diecast parts such as the switch box are made of corrosion-proof aluminum. Rubber-sealing parts are made of fluorine rubber and exposed nuts and screws are made of stainless steel. These all aid in resisting oil, chemicals and adverse weather conditions.			
Outdoor specifications	WL□-P1	--- (See note 5.)	Yes (See note 6.)	---	Rotary shafts are made of unquenched (i.e., untreated) stainless steel to improve corrosion resistance. Exposed nuts and screws are made of stainless steel and rubber sealing parts of silicone rubber. These factors all combine to create a product which is resistant to temperature changes and adverse weather conditions.			
Lamp-equipped	WL□-LE	Yes			Operating status can be checked at a glance. Lit when operating and not lit when not operating.		62	
	WL□-LD	Yes			WL□-LE: 100 VAC/DC min. WL□-LD: 115 VAC/DC min. (Refer to page 58 for detailed ratings.)			
Relevant pages			Pages 42 to 62			---	---	

Note: 1. Do not expose to extreme changes in temperature.







2. Standard Models: Operate on each side at an angle of 45°. Possible to set to one-side operation on either side. Pretravel (PT) is 15°.
- Overtravel Models: Standard and high-sensitivity models operate on each side at an angle of 80°. Not possible to set to one-side operation. -2N Series operate on each side at an angle of 90°. Possible to set to one-side operation on either side.
- High-precision Models: Operate on each side at an angle of 45°. Possible to set to one-side operation on either side. Pretravel (PT) is 5°.

3. When ordering, add the suffix for the environment-resistant model or indicator specifications required according to the operating environment and purpose.
4. The overtravel model (-2N Series), fork lever lock model (WLCA32-41 to 44), horizontal plunger (WLS□) model, heat-resistant model, low-temperature model, and lamp-equipped model cannot be used with the corrosion-proof model.
5. Outdoor specifications are available for some standard models. Consult your OMRON representative for details.
6. Outdoor specifications are only available for general models and high-sensitivity models.

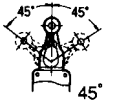
■ List of Models

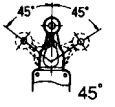
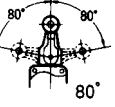
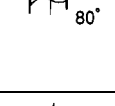
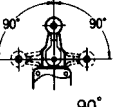

Rotating Lever Models

Roller Lever Models: Short, Medium, and Long Lever Models

Type		Total travel (TT)	Features	Actuator (See note 2.)		
				WL-1A100 Roller Lever: Short lever (R38)	WL-1A200 Roller Lever: Medium lever (R50)	WL-1A300 Roller Lever: Long lever (R63)
						
Standard			One-side operation is possible. (See note 3.) Head can be mounted in any of the four directions.	WLCA2	WLCA2-7	WLCA2-8
Over-travel	General		One-side operation is impossible. (See note 3.) Head can be mounted in any of the four directions.	WLH2	---	---
	High-sensitivity		One-side operation is possible. (See note 3.) Head can be mounted in any of the four directions.	WLG2	---	---
	-2N Series		One-side operation is possible. (See note 3.) Head can be mounted in any of the two directions. (When the Head can be mounted horizontally, the Head can be mounted in any of the four directions.)	WLCA2-2N	---	---
High-precision			One-side operation is possible. (See note 3.) Head can be mounted in any of the four directions.	WLGCA2	---	---

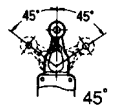
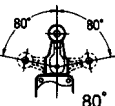
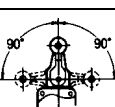
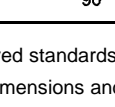

- Note:**
1. For the approved standards file numbers, refer to page 32.
 2. For external dimensions and other information, refer to pages 53 to 56.
 3. One-side operation means that three operational directions can be selected electrically, according to the change in direction of the operating plunger. Those models for which one-side operation is impossible can only operate on both sides. For details, see page 70.

Adjustable Roller Levers and Adjustable Rod Levers

Type		Total Travel (TT)	Features	Actuator (See note 2.)	
				WL-2A100 Adjustable Roller Lever 	WL-4A100 Adjustable Rod Lever (Adjustable length: 25 to 140 mm) WL-3A100 (Adjustable length: 350 to 380 mm) 
Standard			One-side operation possible. (See note 3.) Head can be mounted in any of the four directions.	WLCA12 ---	--- WLCL (WL-4A100)
Over-travel	General		One-side operation possible. (See note 3.) Head can be mounted in any of the four directions.	WLH12	WLHL (WL-4A100) WLHAL4 (WL-3A100)
	High-sensitivity		One-side operation possible. (See note 3.) Head can be mounted in any of the four directions.	WLG12	WLGL (WL-4A100)
	-2N Series		One-side operation is possible. (See note 3.) Head can be mounted in any of the two directions. (When the Head can be mounted horizontally, the Head can be mounted in any of the four directions.)	WLCA12-2N	WLCL-2N (WL-4A100)

- Note:**
- For the approved standards file numbers, refer to page 32.
 - For external dimensions and other information, refer to pages 53 to 56.
 - One-side operation means that three operational directions can be selected electrically, according to the change in direction of the operating plunger. The operating plunger is set for operation on both sides before delivery. Those models for which one-side operation is impossible can only operate on both sides. For details, see page 70. The operational plunger is factory-set to both sides.

Rod Spring Levers and Fork Lever Locks

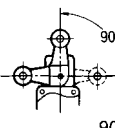
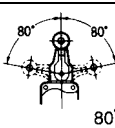



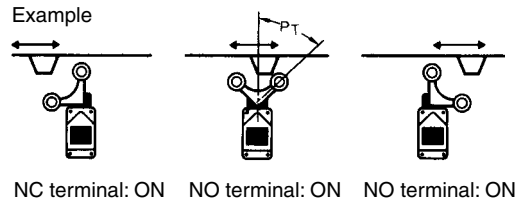

Type		Total travel (TT)	Features	Actuator (See note 2.)	
				WL-3A200 Rod Spring Lever 	Fork Lever Locks: WL-5A100, WL-5A102, WL-5A104 
Protective			Head can be mounted in any of the four directions.	---	WLCA32-41 (WL-5A100) WLCA32-42 (WL-5A102) WLCA32-43 (WL-5A104)
Over-travel	General		One-side operation is possible. (See note 3.) Head can be mounted in any of the four directions.	WLHAL5	---

- Note:**
- For the approved standard file numbers, refer to page 32.
 - For external dimensions and other information, refer to pages 53 to 56.
 - One-side operation means that three operational directions can be selected electrically, according to the change in direction of the operating plunger. The operating plunger is set for operation on both sides before delivery. Those models for which one-side operation is impossible can only operate on both sides. For details, see page 70. The operational plunger is factory-set to both sides.

4. The fork lever lock is configured so that the dog pushes the lever to reverse the output and this reversed state is maintained even after the dog continues on. If the dog then pushes the lever from the opposite direction, the lever will return to its original position.





Standard Plungers

Type	Actuators	Model
Top	Top Plunger 	WLD
	Top-roller Plunger 	WLD2 WLD28 (see note 2.)
	Top-ball Plunger 	WLD3
Horizontal	Horizontal Plunger 	WLSD
	Horizontal-roller Plunger 	WLSD2
	Horizontal-ball Plunger 	WLSD3

- Note:** 1. For the approved standards file numbers, refer to page 32.
2. Sealed roller.

Standard Flexible Rods

Actuators		Model
Coil spring 	Spring dia. 6.5	WLNJ
	Spring dia. 4.8	WLNJ-30
	Resin rod dia. 8.0	WLNJ-2
Steel wire 	1.0-dia. wire	WLNJ-S2

Note: For the approved standards file numbers, refer to page 32.

Microload Models

A series of microload models has also been developed for the configurations outlined on pages 34 to 36. The model numbers become WL01□. For example, WLCA2 becomes WL01CA2.

Model Number Legend

WL□□-□□□□□□□□□□
1 2 3 4 5 6 7 8 9 10 11

1. Electrical Rating

Blank: Standard
01: Miniature

2. Actuator and Head Specifications

Symbol Actuator type

CA2 Roller lever: Standard (R38)
CA2-7 Roller lever: Standard, medium lever (R50)
CA2-8 Roller lever: Standard, long lever (R63)
H2 Roller lever: Overtravel, general-purpose model, 80°
G2 Roller lever: Overtravel, high-sensitivity, 80°
CA2-2 NRoller lever: Overtravel, 90°
GCA2 Roller lever: High-precision
CA12 Adjustable roller lever: Standard
H12 Adjustable roller lever: Overtravel, general-purpose model, 80°
G12 Adjustable roller lever: Overtravel, high-sensitivity, 80°
CA12-2N Adjustable roller lever: Overtravel, 90°
CL Adjustable rod lever: Standard
HL Adjustable rod lever: Overtravel, general-purpose model, 80°, 25 to 140 mm
HLAL4 Adjustable rod lever: Overtravel, general-purpose model, 80°, 350 to 380 mm
GL Adjustable rod lever: Overtravel, high-sensitivity, 80°, 25 to 140 mm
CL-2N Adjustable rod lever: Overtravel, 90°, 25 to 140 mm
HAL5 Rod spring lever: Protective, Overtravel, general-purpose model, 80°
CA32-41 Fork lever lock: Protective, WL-5A100
CA32-42 Fork lever lock: Protective, WL-5A102
CA32-43 Fork lever lock: Protective, WL-5A104
D Plunger: Top plunger
D2 Plunger: Top-roller plunger
D28 Plunger: Top-roller plunger, sealed
D3 Plunger: Top-ball plunger

Switches without levers

WLRCA2
WLRCA2
WLRCA2
WLRH2
WLRG2
WLRCA2-2N
WLRGCA2
WLRCA2
WLRH2
WLRG2
WLRCA2-2N
WLRCL
WLRH2
WLRH2
WLRG2
WLRCA2-2N
WLRH2
WLRCA32
WLRCA32
WLRCA32

Symbol	Actuator type	Switches without levers
SD	Plunger: Horizontal plunger	---
SD2	Plunger: Horizontal-roller plunger	---
SD3	Plunger: Horizontal-ball plunger	---
NJ	Flexible rod: Coil spring	---
NJ-30	Flexible rod: Coil spring, multi-wire	---
NJ-2	Flexible rod: Coil spring, resin rod	---
NJ-S2	Flexible rod: Steel wire	---

3. Environment-resistant Model Specifications

Blank:	Standard
RP:	Corrosion-proof (See note 1.)
P1:	Weather-resistant (See note 1.)

4. Built-in Switch Specifications

Blank:	General-purpose built-in switch
55:	Hermetically-sealed built-in switch (See note 1.)

5. Temperature Specifications

Blank:	Standard: -10°C to 80°C
TH:	Heat-resistive: 5°C to 120°C (See note 1.)
TC:	Low temperature: -40°C to 40°C (See note 1.)

6. Special Hermetic Model Specifications

Blank:	No cables or molding
139:	General-purpose built-in switch with cables attached and molded conduit opening and cover (cover cannot be removed). (See note 1.)
140:	Airtight built-in switch with cables attached and molded conduit opening, cover, and case cover (cover cannot be removed). (See note 1.)
141:	Airtight built-in switch with cables attached and molded conduit opening, cover, and case cover (cover cannot be removed). The Head opening is created to protect it from cutting powder. (See note 1.)
RP40:	Airtight built-in switch with cables attached, SC Connector can be used, molded conduit opening, cover, and case cover (cover cannot be removed). (See note 1.)
RP60:	Airtight built-in switch with cables attached, fluorine rubber-molded conduit opening, cover, and case cover (cover cannot be removed). (See note 1.)

7. Conduit Size, Ground Terminal Specifications

Blank:	G 1/2	Without ground terminal
G1:	G 1/2	With ground terminal
G:	Pg13.5	With ground terminal
Y:	M20	With ground terminal
TS:	1/2-14NPT	With ground terminal

8. Indicator Type

	Element	Voltage	Leakage Current
Blank:	No indicators		
LE:	Neon lamp	125 to 250 VAC	Approx. 0.6 to 1.9 mA
LD:	LED	10 to 115 VAC/VDC	Approx. 1 mA

9. Lever Type

Blank:	Allen-head lever (standard)
A:	Double nut lever

10.

Blank:	Standard
S:	Spatter-proof model (See note 2.)

11. Conduit Wiring Specifications

Blank:	Screw-tightened terminal (G1/2 conduit)
K13:	Direct-wired Connector (2-core, DC)
K13A:	Direct-wired Connector (2-core, AC)
K43:	Direct-wired Connector (4-core, DC)
K43A:	Direct-wired Connector (4-core, AC)
-M1J:	Pre-wired Connector (2-core, DC) with 0.3-m cable attached.
-AGJ03:	Pre-wired Connector (4-core, AC) with 0.3-m cable attached.
-DGJ03:	Pre-wired Connector (4-core, DC) with 0.3-m cable attached.
-DK1EJ03:	Pre-wired Connector (3-core, DC) with 0.3-m cable attached.

- Note:**
1. For information on applicable models, see page 60 to 62.
 2. For information on applicable models, see pages 57 to 60.

General-purpose Models

These Limit Switches are two-circuit double-break switches housed in rugged diecast, thus making it an oil-tight, waterproof and dustproof construction (complies with IP67).

In addition to the standard models, microload models are also available.

A wide range of actuators with a range of functions are available; rotating lever, plunger, flexible rod etc.

The rubber material in the standard models is designed to be resistant to water and most oils.

■ Nomenclature

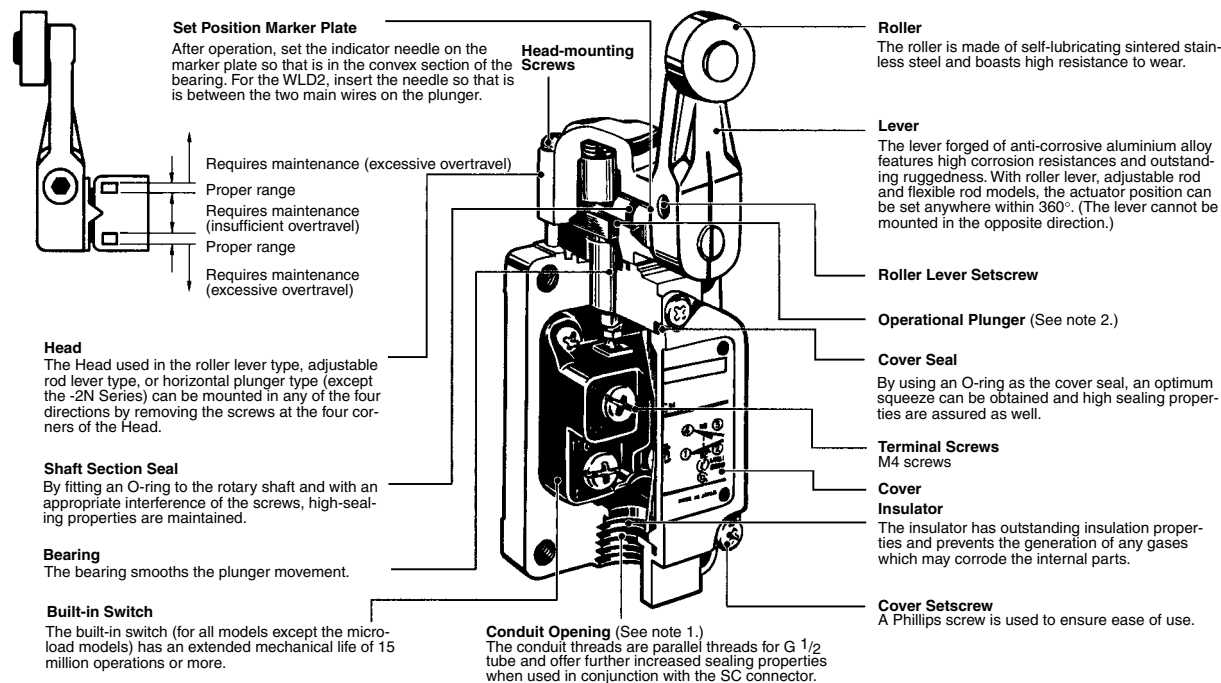

Note: 1. The display for conduit threads has changed from PF¹/₂ to G¹/₂, according to revisions of JIS B 0202. This is only a change in the display, so the thread size and pitch have not changed. (Conduit threads Pg 13.5 and ¹/₂-14NPT are also available.)

2. By changing the orientation of the operational plunger, three operational directions can be selected electrically. (This is only possible with general-purpose roller lever, adjustable roller lever, and adjustable rod lever models. For the overtravel models, only -2N Series models have this function.)

■ Ratings

Type	Rated voltage	Non-inductive load				Inductive load			
		Resistive load		Lamp load		Inductive load		Motor load	
		NC	NO	NC	NO	NC	NO	NC	NO
Standard, overtravel (except high-sensitivity models), and high-precision models.	125 VAC	10 A	10 A	3 A	1.5 A	10 A		5 A	2.5 A
	250 VAC	10 A	10 A	2 A	1 A	10 A		3 A	1.5 A
	500 VAC	10 A	10 A	1.5 A	0.8 A	3 A		1.5 A	0.8 A
	8 VDC	10 A		6 A	3 A	10 A		6 A	
	14 VDC	10 A		6 A	3 A	10 A		6 A	
	30 VDC	6 A		4 A	3 A	6 A		4 A	
	125 VDC	0.8 A		0.2 A	0.2 A	0.8 A		0.2 A	
	250 VDC	0.4 A		0.1 A	0.1 A	0.4 A		0.1 A	
Overtravel (high-sensitivity)	125 VAC	5 A		---		---		---	
	250 VAC	5 A		---		---		---	
	125 VDC	0.4 A		---		---		---	
	250 VDC	0.2 A		---		---		---	

Note: 1. The above figures are for standard currents.

2. Inductive loads have a power factor of 0.4 min. (AC) and a time constant of 7 ms max. (DC).

3. Lamp load has an inrush current of 10 times the steady-state current.

4. Motor load has an inrush current of 6 times the steady-state current.
5. For PC loads, use the microload models.

Inrush current	NC	30 A max. (15 A max. (see note))
	NO	20 A max. (10 A max. (see note))

Note: Only for high-sensitivity overtravel models.

Microload Models

Rated voltage	Resistive load
125 VAC	0.1 A
30 VDC	

Operation within the three zones illustrated in the following diagram will produce optimum performance.

Recommended Load Range: 5 to 30 VDC, 0.5 to 100 mA

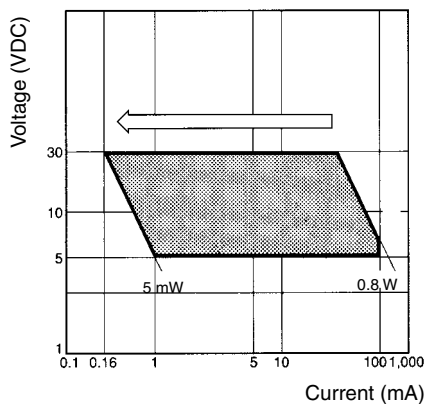

Ground Terminal Models

WL -
1 2

- 1: Type of actuator
- 2: Conduit opening size

The models differ depending on the size of the case's conduit thread.

Model	Conduit opening size
G1	G 1/2
G	Pg 13.5
Y	M20
TS	1/2-14NPT

Contact Form

Standard (WL) / Microload (WL01) Models

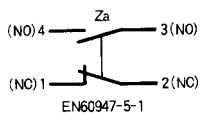
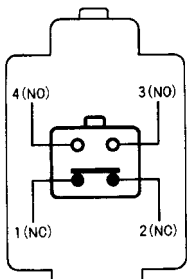

■ Approved Standard Ratings

UL/CSA

Standard Models: A600

Rated voltage	Carry current	Current		Volt-amperes	
		Make	Break	Make	Break
120 VAC	10 A	60 A	6 A	7,200 VA	720 VA
240 VAC		30 A	3 A		
480 VAC		15 A	1.5 A		
600 VAC		12 A	1.2 A		

Microload Models:
0.1 A 125 VAC, 0.1 A 30 VDC

TÜV (EN60947-5-1)

(Only Ground Terminal Models are Approved)

Model	Category/rating	Thermal current	Indicator
WL□-□	AC-15 2 A/250 V DC12 2 A/48 V	10 A	---
WL01□-□	AC-14 0.1 A/125 V DC12 0.1 A/48 V	0.5 A	---
WL□-□LE	AC-15 2 A/250 V	10 A	Neon lamp
WL01□-□LE	AC-14 0.1 A/125 V	0.5 A	Neon lamp
WL□-□LD	AC-15 2 A/115 V DC12 2 A/48 V	10 A	LED
WL01□-□LD	AC-14 0.1 A/115 V DC12 0.1 A/48 V	0.5 A	LED

Note: As an example, AC-15 2 A/250 V means the following:

Application category	AC-15
Rated operating current (Ie)	2 A
Rated operating voltage (Ue)	250 V

■ Characteristics

Degree of protection	IP67
Life expectancy (see note 3)	Mechanical: 15,000,000 operations min. (see note 4) Electrical: 750,000 operations min. (see note 5)
Operating speed	1 mm to 1 m/s (for WLCA2)
Operating frequency	Mechanical: 120 operations/minute min. Electrical: 30 operations/minute min.
Rated frequency	50/60 Hz
Insulation resistance	100 M Ω min. (at 500 VDC)
Contact resistance	25 m Ω max. (initial value)
Dielectric strength	1,000 VAC (600 VAC), 50/60 Hz for 1 min between non-continuous terminals. 2,200 VAC, 50/60 Hz for 1 min/Uimp 2.5 kV non-current-carrying metal part and ground. 2,200 VAC, 50/60 Hz for 1 min Uimp 2.5 kV between each terminal and non-current-carrying metal part.
Rated insulation voltage (U _i)	250 V (EN60947-5-1)
Switching overvoltage	1,000 V max. (EN60947-5-1)
Pollution degree (operating environment)	3 (EN60947-5-1)
Short-circuit protective device (SCPD)	10 A, fuse type gG or gI (IEC269)
Conditional short-circuit current	100 A (EN60947-5-1)
Conventional enclosed thermal current (I _{the})	10 A, 0.5 A (EN60947-5-1)
Protection against electric shock	Class I
Vibration resistance	10 to 55 Hz, 1.5-mm double amplitude (see note 6)
Shock resistance	Destruction: 1,000 m/s ² min. Malfunction: 300 m/s ² min. (see note 6)
Ambient temperature	Operating: -10°C to 80°C (with no icing) (see note 7)
Ambient humidity	Operating: 95% max.
Weight	Approx. 275 g (in the case of WLCA2)

- Note:**
- The above figures are initial values.
 - The figures in parentheses for dielectric strength, are those for the overtravel (high-sensitivity) model.
 - Life expectancy values are calculated at an operating temperature of 5°C to 35°C, and an operating humidity of 40% to 70%. Contact your OMRON sales representative for more detailed information on other operating environments.
 - 10,000,000 operations min. for general, high-sensitivity, and flexible rod overtravel models.
 - 500,000 operations min. for high-precision and outdoor specifications models. All microload models however, are 1,000,000 operations min.
 - Except the flexible rod models.
 - For low temperature models this is -40°C to 40°C (no icing). For heat-resistive models the range is +5°C to 120°C.

Engineering Data

Electrical Life Expectancy

Operating temperature: 5°C to 30°C

Operating humidity: 40% to 70%.

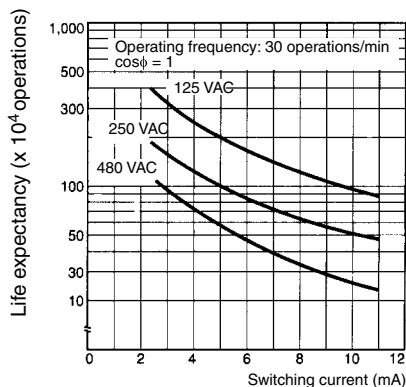

Standard Models

■ Dimensions/Operating Characteristics

- Note:** 1. Rotating Lever Models: For all models WL□ indicates a standard model and WL01□ indicates a microload model.
2. Unless otherwise indicated, a tolerance of ± 0.4 mm applies to all dimensions.

Roller Lever

WLCA2
WL01CA2

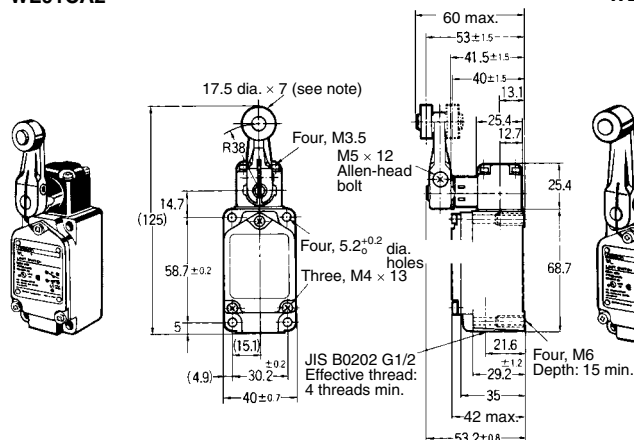

Note: Stainless sintered roller

Roller Lever

WLCA2-7
WL01CA2-7

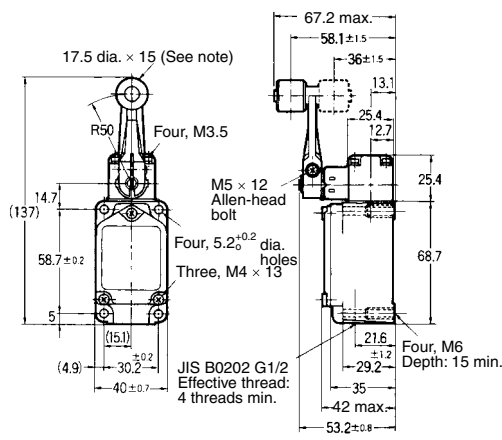

Note: Stainless steel roller

Roller Lever

WLCA2-8
WL01CA2-8

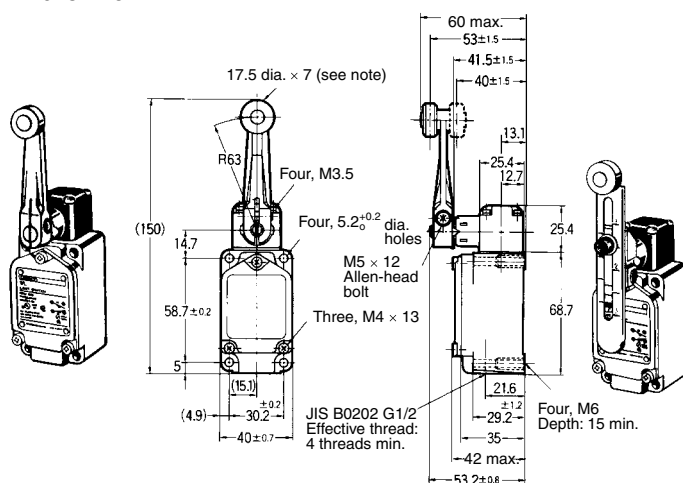

Note: Stainless sintered roller

Adjustable Roller Lever

WLCA12
WL01CA12

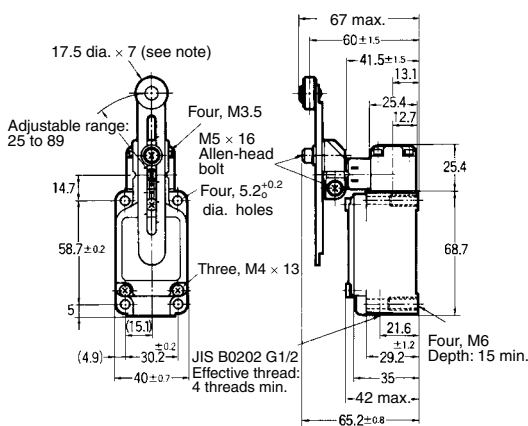

Note: Stainless sintered roller

Operating characteristics	WLCA2 WL01CA2	WLCA2-7 WL01CA2-7	WLCA2-8 WL01CA2-8	WLCA12 WL01CA12 (see note)
Operating force: OF max.	13.34 N	10.2 N	8.04 N	13.34 N
Release force: RF min.	2.23 N	1.67 N	1.34 N	2.23 N
Pretravel: PT	15 \pm 5°	15 \pm 5°	15 \pm 5°	15 \pm 5°
Overtravel: OT min.	30°	30°	30°	30°
Movement differential: MD max.	12°	12°	12°	12°

Note: The operating characteristics for WLCA12 and WL01CA12 are measured at the lever length of 38 mm.

OF and RF for WLCA12, with a lever length of 89 mm.

Operating characteristics	WLCA12, WL01CA12
OF	5.68 N
RF	0.95 N

Rotating Lever Models: For all models WL indicates a standard model and WL01□ indicates a microload model.

Adjustable Rod Lever

WLCL
WL01CL

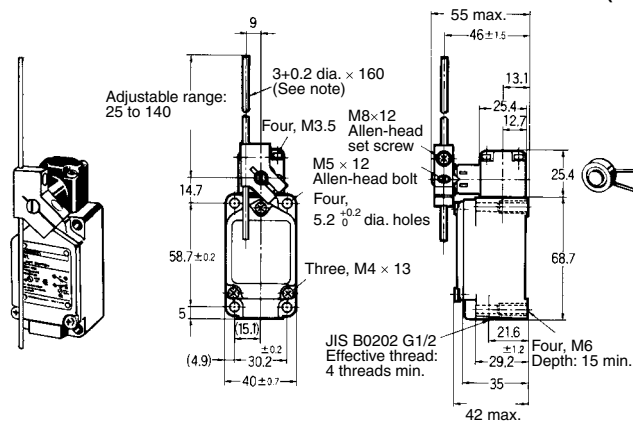

Note: Stainless steel rod

Fork Lever Lock

WLCA32-41 to 44
WL01CA32-41 to 44
(For details see page 35.)

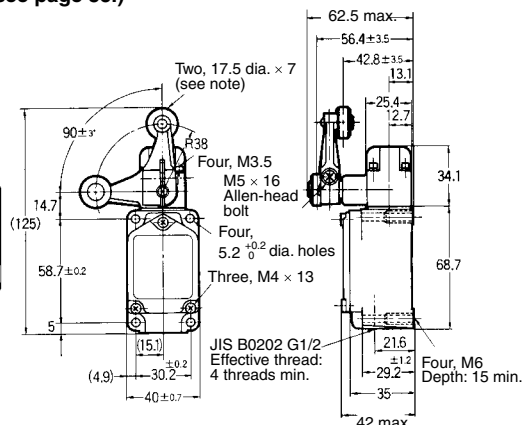

Note: Plastic roller. This illustration shows the external dimensions of the WLCA32-41. (Models WLCA32-041 to -044 have stainless steel rollers.)

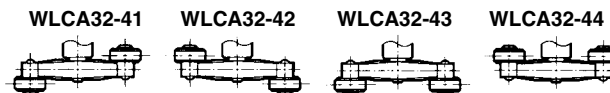

- Note:**
1. Unless otherwise indicated, a tolerance of ±0.4 mm applies to all dimensions.
 2. The fork lever lock is configured so that the dog pushes the lever to reverse the output and this reversed state is maintained even after the dog continues on. If the dog then pushes the lever from the opposite direction, the lever will return to its original position.

Example

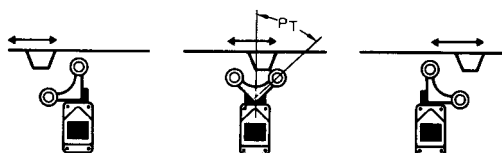

NC terminal: ON NO terminal: ON NO terminal: ON

Operating characteristics	WLCL, WL01CL
Operating force: OF max.	1.39 N
Release force: RF min.	0.27 N
Pretravel: PT	15±5°
Overtravel: OT min.	30°
Movement differential: MD max.	12°

Note: The operating characteristics for WLCA12 and WL01CA12 are measured at the lever length of 140 mm.

Operating characteristics	WLCA32-41 to 44, WL01CA32-41 to 44
Force necessary to reverse the direction of the lever: Max.	11.77 N}
Movement until the lever reverses	50±5°
Movement until switch operation: Max.	55°
Movement after switch operation: Min.	35°

- Note:** 1. Plunger Models: For all models WL□ indicates a standard model and WL01□ indicates a microload model.
2. Unless otherwise indicated, a tolerance of ± 0.4 mm applies to all dimensions.

Top Plunger

WLD
WL01D

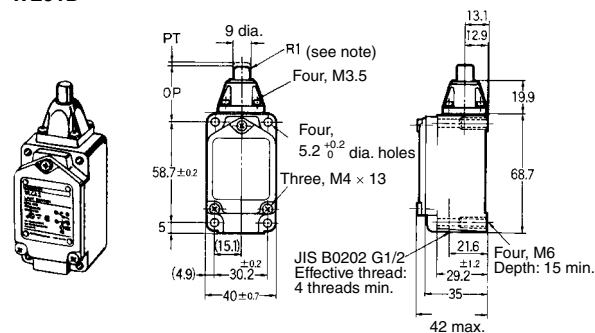

Note: Stainless steel plunger

Horizontal Plunger

WLS
WL01SD

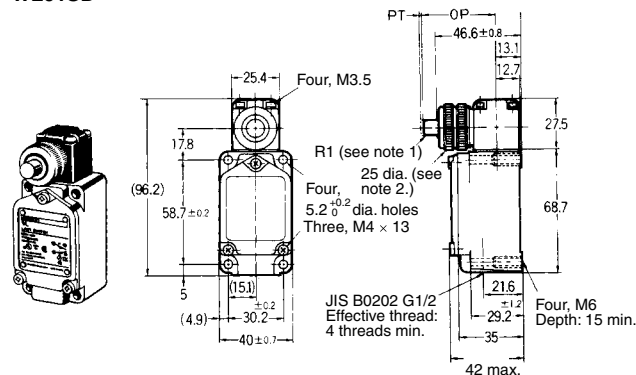

- Note:** 1. Stainless steel plunger
2. Cosmetic nuts.

Top-roller Plunger

WLD2
WL01D2

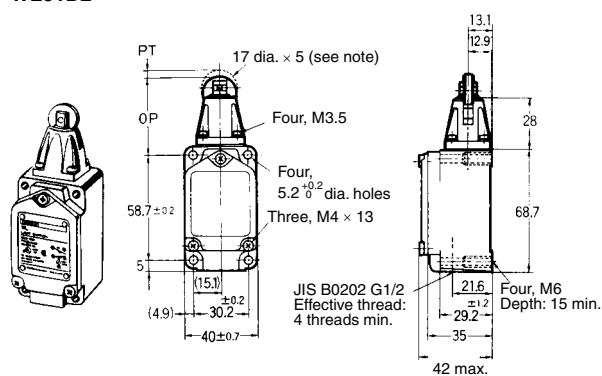

Note: Stainless sintered roller

Horizontal-roller Plunger

WLS2
WL01SD2

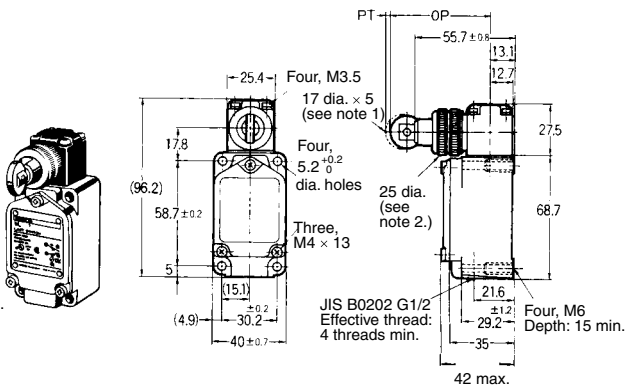

- Note:** 1. Stainless sintered roller
2. Cosmetic nuts
3. The WLS2D1 model, which has the roller rotated by 90° is also available.

Note: Unless otherwise indicated, a tolerance of ± 0.4 mm applies to all dimensions.

Top-ball Plunger

WLD3
WL01D3

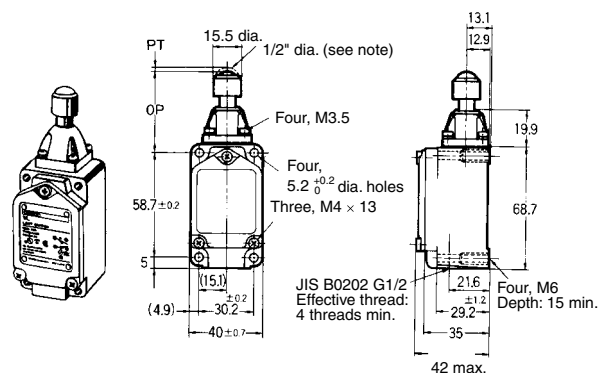

Note: Stainless steel ball

Horizontal-ball Plunger

WLS3
WL01SD3

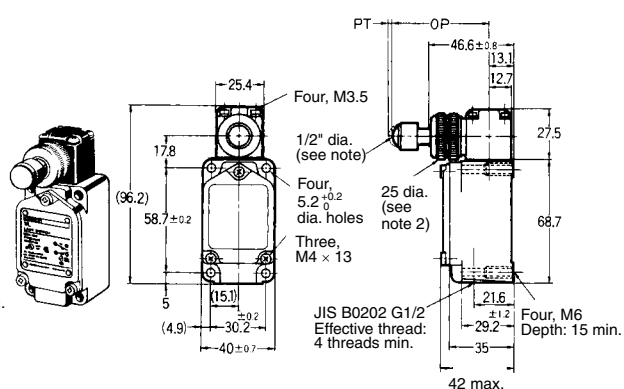

Note: 1. Stainless steel ball
2. Cosmetic nuts

Sealed Top-roller Plunger

WLD28
WL01D28

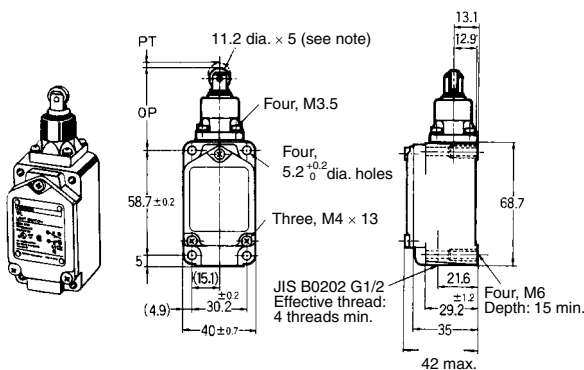

Note: Stainless steel ball

Operating characteristics	WLD WL01D	WLD2 WL01D2	WLD3 WL01D3	WLD28 WL01D28	WLS2 WL01SD2	WLS3 WL01SD3	WLS3 WL01SD
Operating force: OF max.	26.67 N	26.67 N	26.67 N	16.67 N	40.03 N	40.03 N	40.03 N
Release force: RF min.	8.92 N	8.92 N	8.92 N	4.41 N	8.89 N	8.89 N	8.89 N
Pretravel: PT max.	1.7 mm	1.7 mm	1.7 mm	1.7 mm	2.8 mm	2.8 mm	2.8 mm
Overtravel: OT min.	6.4 mm	5.6 mm	4 mm	5.6 mm	5.6 mm	4 mm	6.4 mm
Movement differential: MD max.	1 mm	1 mm	1 mm	1 mm	1 mm	1 mm	1 mm
Operating position: OP	34±0.8 mm	44±0.8 mm	44.5±0.8 mm	44±0.8 mm	54.2±0.8 mm	54.1±0.8 mm	40.6±0.8 mm
Total travel position: TTP max.	29.5 mm	39.5 mm	41 mm	39.5 mm	---	---	---

- Note:** 1. Flexible Rod Models: For all models WL□ indicates a standard model and WL01□ indicates a microload model.
 2. Unless otherwise indicated, a tolerance of ±0.4 mm applies to all dimensions.

Coil Spring

WLNJ
WL01NJ

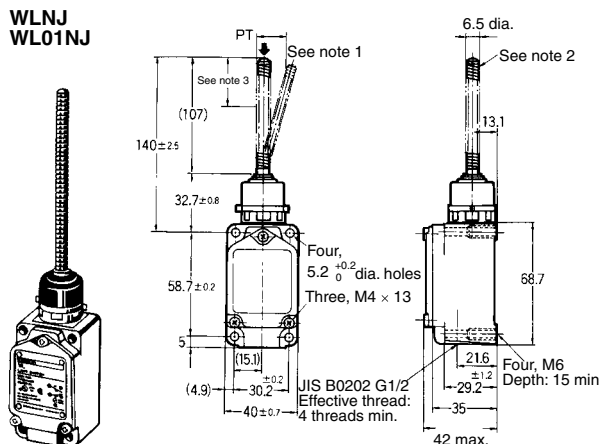

Coil Spring (Multi-wire)

WLNJ-30
WL01NJ-30

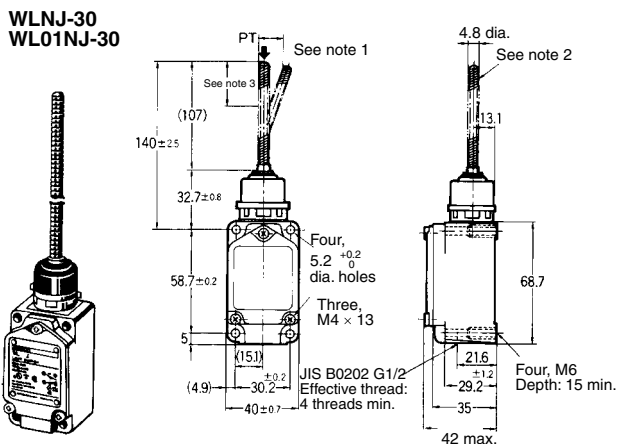

- Note:** 1. The coil spring may be operated from any direction except the axial direction (↓).
 2. Stainless steel coil spring
 3. Optimum operating range of the coil spring is within 1/3 of the entire length from the top end.

- Note:** 1. The coil spring may be operated from any direction except the axial direction (↓).
 2. Piano wire coil
 3. Optimum operating range of the coil spring is within 1/3 of the entire length from the top end.

Coil Spring (Resin Rod)

WLNJ-2
WL01NJ-2

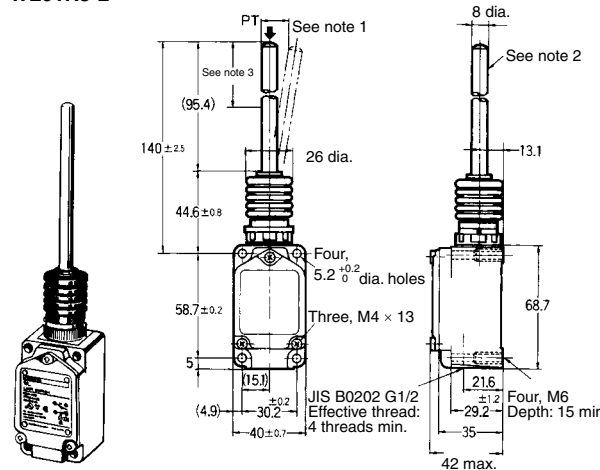

Steel Wire

WLNJ-S2
WL01NJ-S2

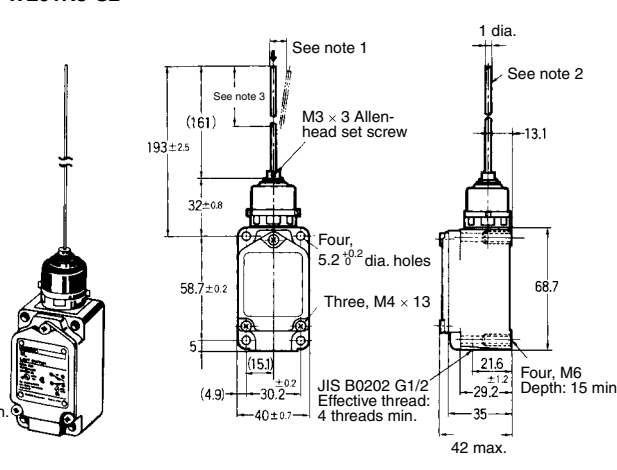

- Note:** 1. The coil spring may be operated from any direction except the axial direction (↓).
 2. Polyamide resin rod
 3. Optimum operating range of the rod is within 1/3 of the entire length from the top end.

- Note:** 1. The coil spring may be operated from any direction except the axial direction (↓).
 2. Stainless steel wire
 3. Optimum operating range of the wire is within 1/3 of the entire length from the top end.

Operating characteristics	WLNJ WL01NJ (see note)	WLNJ30 WL01NJ30 (see note)	WLNJ-2 WL01NJ-2 (see note)	WLNJ-S2 WL01NJ-S2 (see note)
Operating force: OF max.	1.47 N	1.47 N	1.47 N	0.28 N
Pretravel: PT	20±10 mm	20±10 mm	40±20 mm	40±20 mm

Note: These values are taken from the top end of the wire or spring.

Overtravel Models

Overtravel models are Limit Switches which are provided with a greater OT to facilitate dog setting.

The overtravel models are classified into three types; general-purpose, high-sensitivity, and models which are capable of one-side 90° operation, the -2N Series.

The -2N Series can also be installed on either side.

Since this model is identical to the standard model in dimensions, both models are interchangeable.

Like the standard model, it is oil-tight, waterproof, and dustproof (complies with IP67).

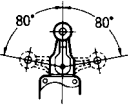
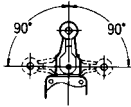
Overtravel Models (1)	Overtravel Models (2)
General-purpose, high sensitivity models	-2N Series
	
Head can be mounted in any of the four directions. The lever operates on either side at 80°. One-side operation is impossible.	The Head can be mounted in two directions, forward and backward. The lever operates on either side at 90°. One side operation is possible.

Overtravel Models (1) General-purpose/High Sensitivity Models

■ Dimensions/Operating Characteristics

- Note:**
1. For all models WL□ indicates a standard model and WL01□ indicates a microload model.
 2. One-side operation is not possible with the general-purpose and high-sensitivity models.
 3. Unless otherwise indicated, a tolerance of ± 0.4 mm applies to all dimensions.

Roller Lever

WLH2
WL01H2
WLG2
WL01G2

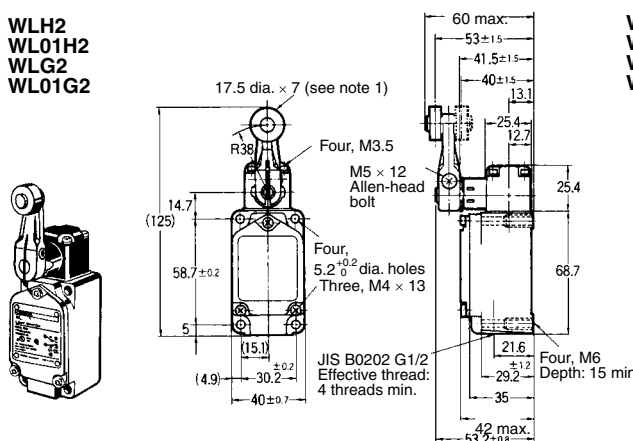

- Note:**
1. Stainless sintered roller
 2. WL□G2 is identical to other models except in the shape of the set position marker plate.
 3. The built-in switch for WLH2 is W-10FB3.
 4. The built-in switch for WLG2 is W-10FB3-8.

Adjustable Rod Lever

WLHL
WL01HL
WLGL
WL01GL

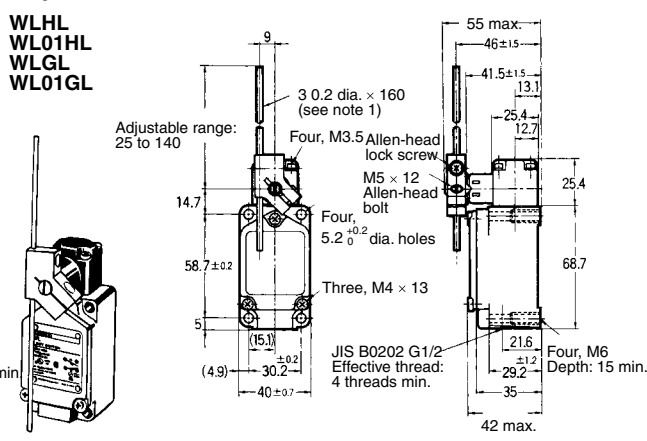

- Note:**
1. WL□GL is identical to other models except in the shape of the set position marker plate.
 2. The built-in switch for WLHL is W-10FB3.
 3. The built-in switch for WLGL is W-10FB3-8.

Adjustable Roller Lever

WLH12
WL01H12
WLG12
WL01G12

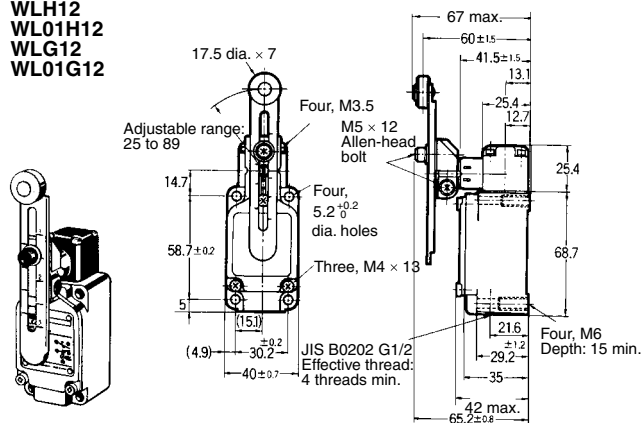

- Note:**
1. Stainless sintered roller
 2. WL□G12 is identical to other models except in the shape of the set position marker plate.
 3. The built-in switch for WLH12 is W-10FB3.
 4. The built-in switch for WLG12 is W-10FB3-8.

Operating characteristics	WLH2 WL01H2	WLG2 WL01G2	WLH12 WL01H12 (see note 1)	WLG12 WL01G12 (see note 1)	WLHL WL01HL (see note 2)	WLGL WL01GL (see note 2)
Operating force: OF max.	9.81 N	9.81 N	9.81 N	9.81 N	2.84 N	2.84 N
Release force: RF min.	0.98 N	0.98 N	0.98 N	0.98 N	0.25 N	0.25 N
Pretravel: PT	15 \pm 5°	10° ⁺² ₋₁	15 \pm 5°	10° ⁺² ₋₁	15 \pm 5°	10° ⁺² ₋₁
Overtravel: OT min.	55°	65°	55°	65°	55°	65°
Movement differential: MD max.	12°	7°	12°	7°	12°	7°

- Note:**
1. The operating characteristics of WLH12, WL01HL12, WLG12, and WL01G12 are measured at the lever length of 38 mm.
 2. The operating characteristics of WLHL, WL01HL, WLGL, and WL01GL are measured at the rod length of 140 mm.

OF and RF for WLH12 and WL01H12, with a lever length of 89 mm.

Operating characteristics	WLH12, WL01H12	WLG12, WL01G12
OF	4.18 N	4.18 N
RF	0.42 N	0.42 N

- Note:** 1. For all models WL□ indicates a standard model and WL01□ indicates a microload model.
2. Unless otherwise indicated, a tolerance of ± 0.4 mm applies to all dimensions.

Adjustable Rod Lever

WLHAL4
WL01HAL4

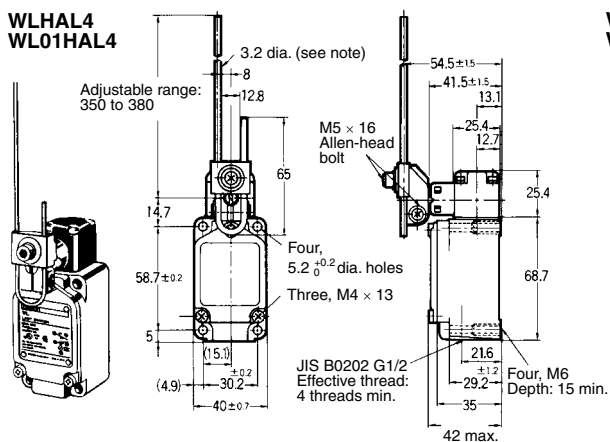

Note: Stainless steel rod

Rod Spring Lever

WLHAL5
WL01HAL5

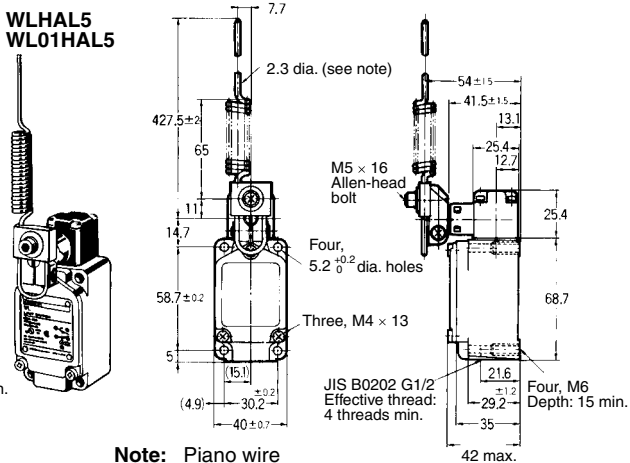

Note: Piano wire

Operating characteristics	WLHAL4 WL01HAL4 (see note 2)	WLHAL5 WL01HAL5
Operating force: OF max.	0.98 N	0.90 N
Release force: RF min.	0.15 N	0.09 N
Pretravel: PT	$15 \pm 5^\circ$	$15 \pm 5^\circ$
Overtravel: OT min.	55°	55°
Movement differential: MD max.	12°	12°

- Note:** 1. With WLHAL4, WL01HAL4, WLHAL5, and WL01HAL5, the actuator's tare is large, so depending on the installation direction, they may not be properly reset. Always install so that the actuator is facing downwards.
2. The operating characteristics of WLHAL4, and WL01HAL4 are measured at the rod length of 380 mm.

Overtravel Models (2)

-2N Series

-2N Series (90° operation on one side is possible by simply changing the direction of the cam.)

■ Dimensions/Operating Characteristics

- Note:**
1. For all models WL□ indicates a standard model and WL01□ indicates a microload model.
 2. With the -2N Series, 90° operation on one side is possible by simply changing the direction of the cam.
 3. Unless otherwise indicated, a tolerance of ± 0.4 mm applies to all dimensions.

Roller Lever

WLCA2-2N
WL01CA2-2N

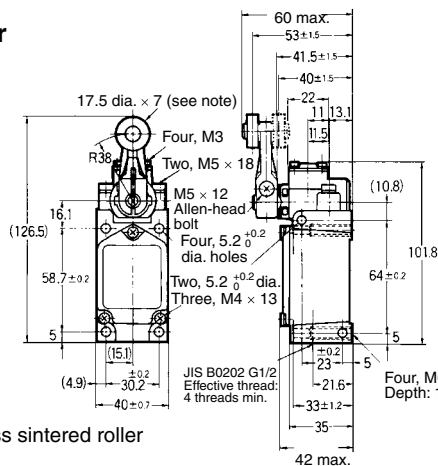
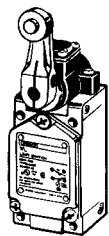

Note: Stainless sintered roller

Adjustable Roller Lever

WLCA12-2N
WL01CA12-2N

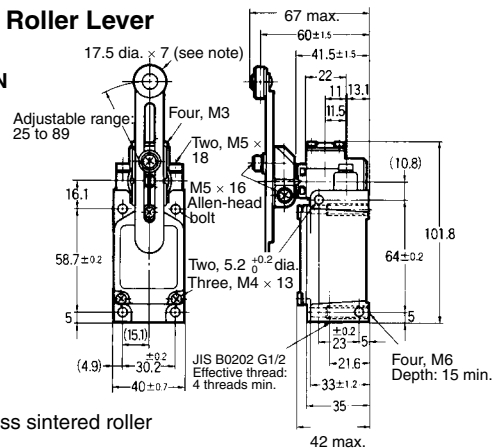
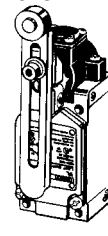

Note: Stainless sintered roller

Adjustable Rod Lever

WLCL-2N
WL01CL-2N

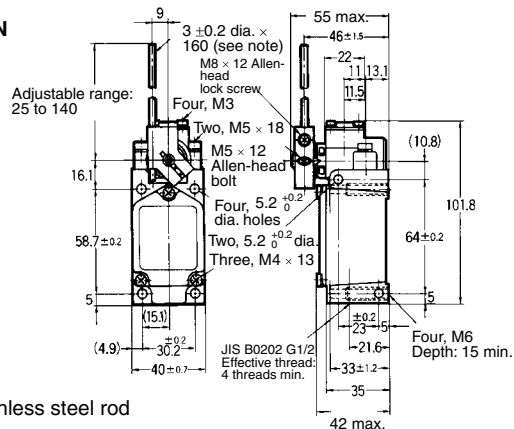
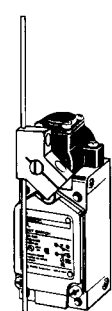

Note: Stainless steel rod

Operating characteristics	WLCA2-2N WL01CA2-2N	WLCA12-2N WL01CA12-2N (see note 1)	WLCL-2N WL01CL-2N (see note 2)
Operating force: OF max.	9.61 N	9.61 N	2.84 N
Release force: RF min.	1.18 N	1.18 N	0.25 N
Pretravel: PT max.	20°	20°	20°
Overtravel: OT min.	70°	70°	70°
Movement differential: MD max.	10°	10°	10°

- Note:**
1. The operating characteristics of WLCA12-2N and WL01CA12-2N are measured at the lever length of 38 mm.
 2. The operating characteristics of WLCL-2N and WL01CL-2N are measured at the rod length of 140 mm.

OF and RF for WLCA12-2N and WL01CA12-2N, with a lever length of 89 mm.

Operating characteristics	WLCA12-2N, WL01CA12-2N
OF	4.10 N
RF	0.50 N

Cam direction changing procedure

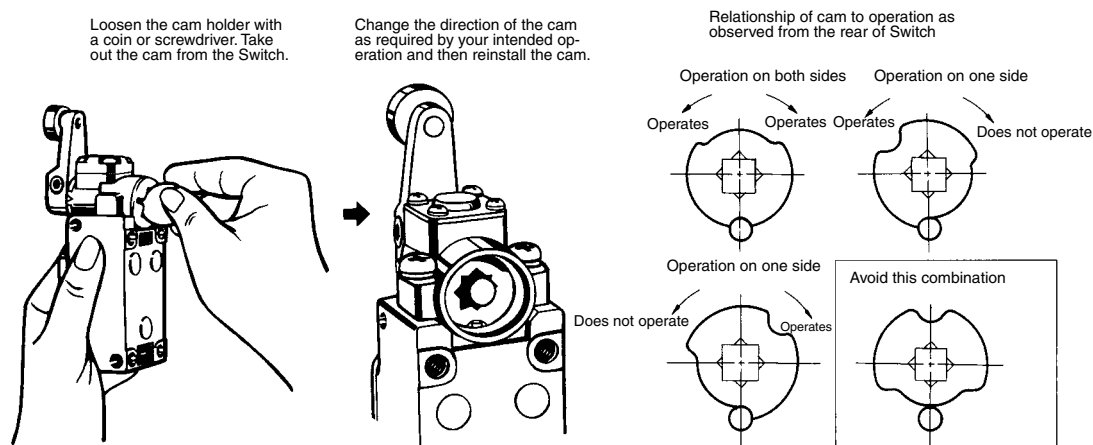

High-precision Models

The high-precision models feature a pretravel of 5° (as compared with 15° for the standard models) and a repeat accuracy twice as great as standard models. The high-precision models are ideal for positioning control of machine tools.

■ Dimensions/Operating Characteristics

For all models WL□ indicates a standard model and WL01□ indicates a microload model.

Note: Unless otherwise indicated, a tolerance of ± 0.4 mm applies to all dimensions.

Roller Lever

WLGA2
WL01GA2

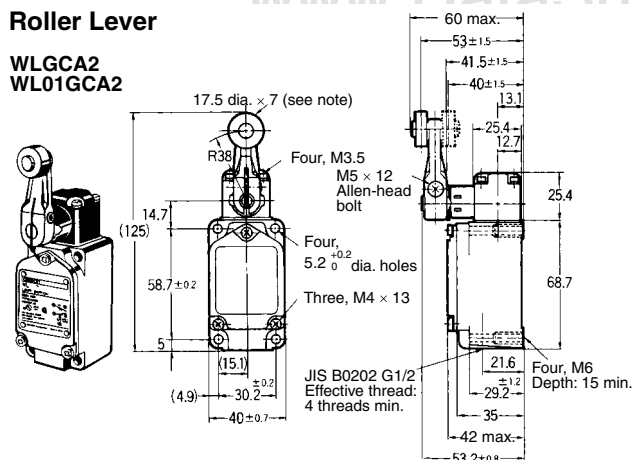

Note: Stainless sintered roller

Operating characteristics	WLGA2 WL01GA2
Operating force: OF max.	13.34 N
Release force: RF min.	1.47 N
Pretravel: PT	$5^\circ \begin{smallmatrix} +2 \\ 0 \end{smallmatrix}$
Overtravel: OT min.	40°
Movement differential: MD max.	3°

Connector Models

The connector models allow easy maintenance.

■ Dimensions/Operating Characteristics

Note: Unless otherwise indicated, a tolerance of ± 0.4 mm applies to all dimensions.

High-sensitivity

WLG2-□LDK13□
WL01G2-□LDK13□

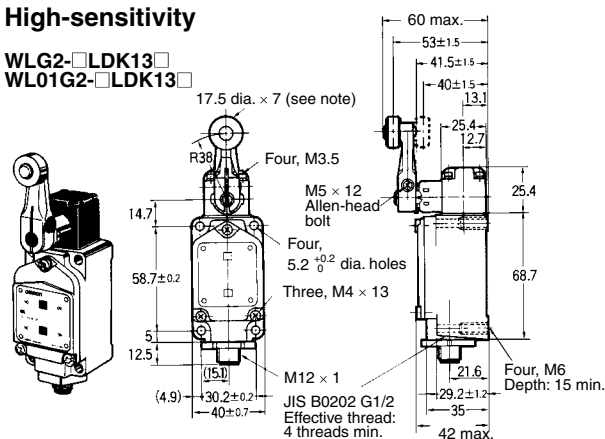

Note: Stainless steel roller

Connector Pin Arrangement

Built in switch terminal No.	Pin NO.
3 (NO)	3
4 (NO)	4

Operating characteristics	WLG2-□LDK13□ WL01G2-□LDK13□
Operating force: OF max.	9.81 N
Release force: RF min.	0.98 N
Pretravel: PT	10° ⁺² ₋₁
Overtravel: OT min.	65°
Movement differential: MD max.	7°
Total travel	80°±5°

High-sensitivity

WLG2-□LDK43□
WL01G2-□LDK43□

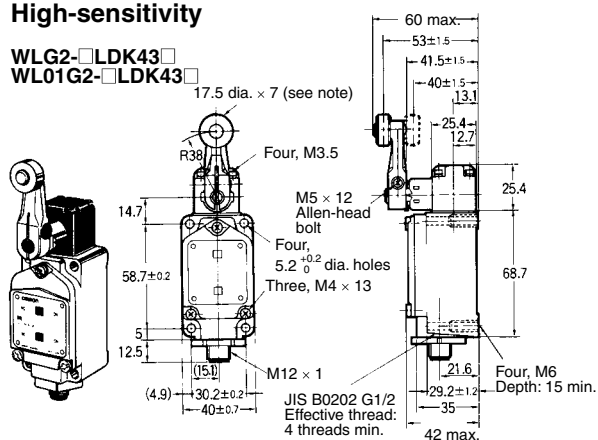

Note: 1. Stainless steel roller
2. The indicator is wired on the NO side.

Connector Pin Arrangement

Built in switch terminal No.	Pin NO.
1 (NC)	1
1 (NC)	2
3 (NO)	3
4 (NO)	4

Operating characteristics	WLG2-□LDK13□ WL01G2-□LDK13□
Operating force: OF max.	9.81 N
Release force: RF min.	0.98 N
Pretravel: PT	10° ⁺² ₋₁
Overtravel: OT min.	65°
Movement differential: MD max.	7°
Total travel	80°±5°

Actuators

■ Dimensions (Levers Only)

Lever: Only rotating lever models are illustrated.

WL-1A100 Standard Lever

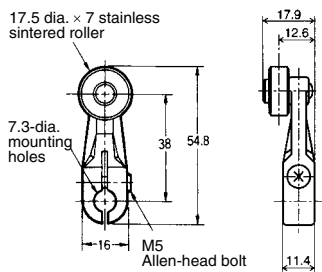

WL-1A115 Resin Roller

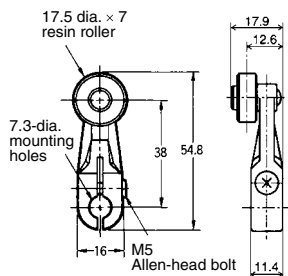

WL-1A400 Bearing Roller

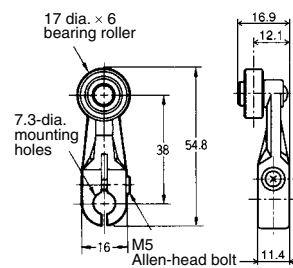

WL-1A118 Nylon Roller: Roller Width: 30 mm

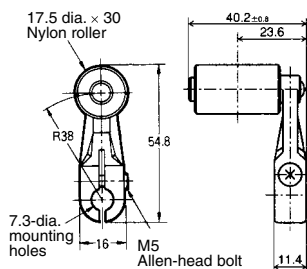

WL-1A105 Double Nut

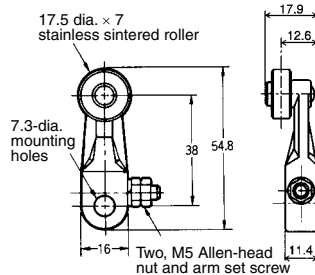

WL-1A103S Spatter Prevention

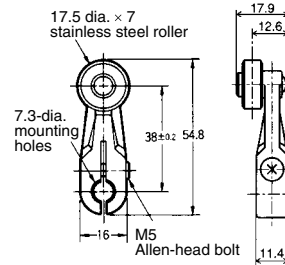

WL-1A200 Lever Length: 50 Roller Width: 15

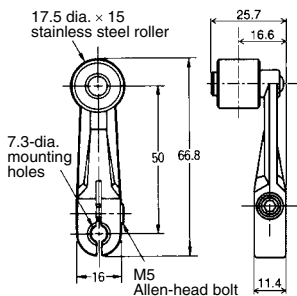

WL-1A300 Lever Length: 63

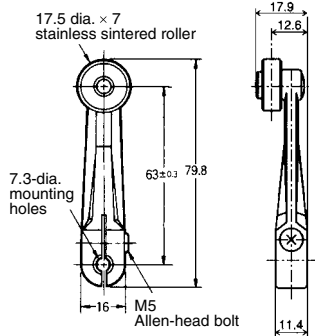

WL-2A100

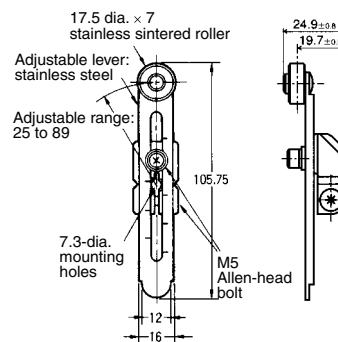

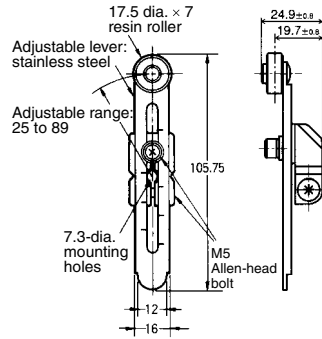
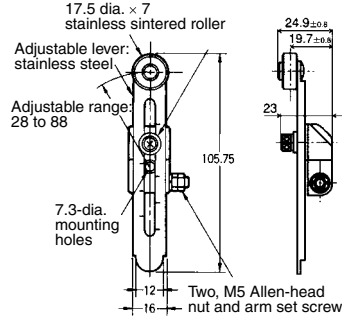
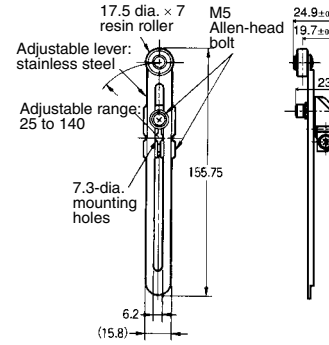
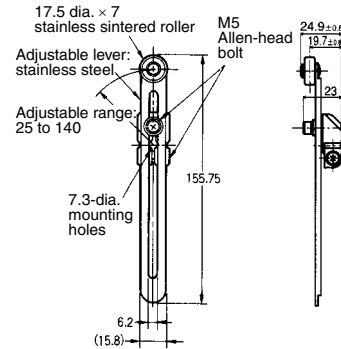
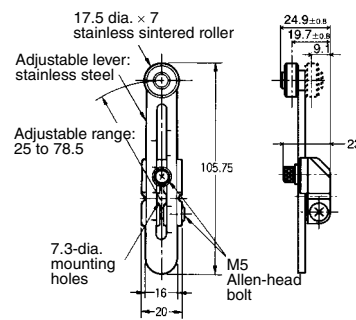
**WL-2A111
Resin Roller****WL-2A107
Double Nut****WL-2A108
Resin Roller****WL-2A122****WL-2A106**

Note: Can be installed on the rear side.

Note: Unless otherwise indicated, a tolerance of ± 0.4 mm applies to all dimensions.

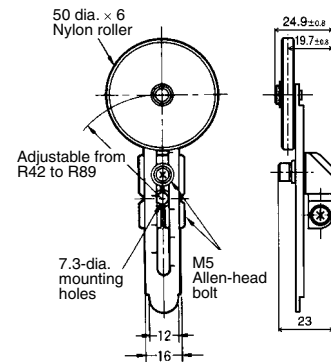
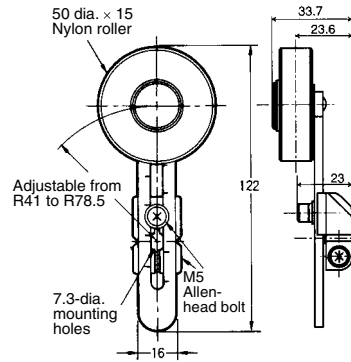
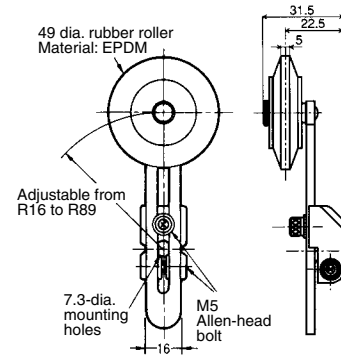
WL-2A104**WL-2A110****WL-2A105**

WL-1A106

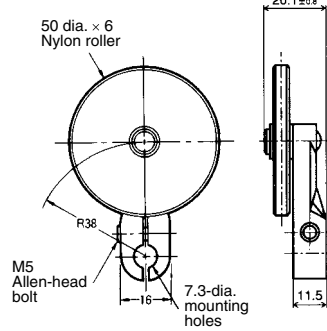

WL-1A110

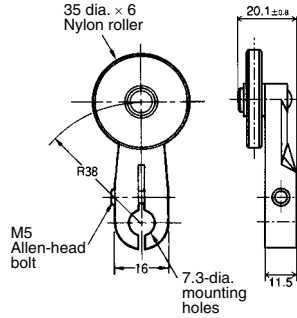

WL-4A100

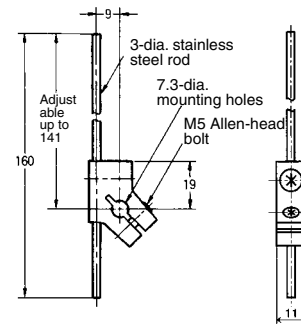

WL-4A201

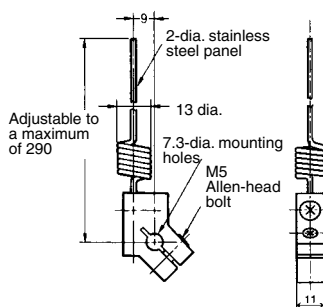

WL-3A100

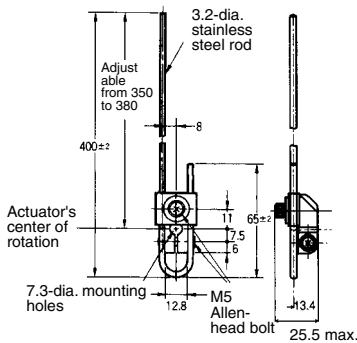
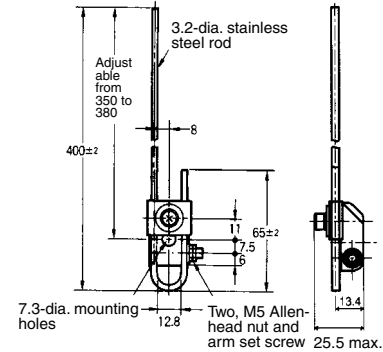
WL-3A106
Double Nut

WL-3A108

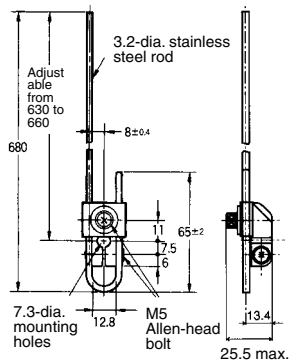

WL-3A200

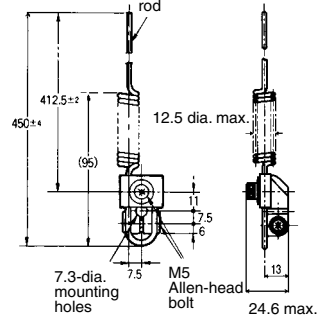

WL-3A203

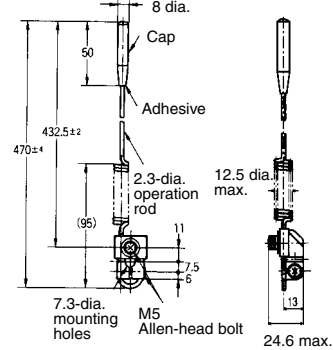

WL-4A112

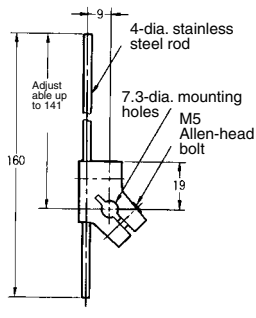

WL-2A129

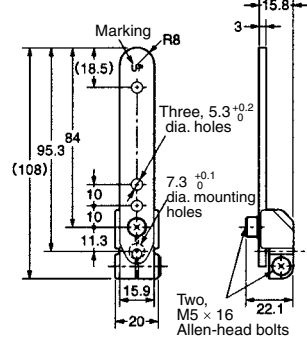

Note: When using the adjustable roller (rod) lever, make sure that the lever is facing downwards. Use caution, as telegraphing (the Switch turns ON and OFF repeatedly due to inertia) may occur.

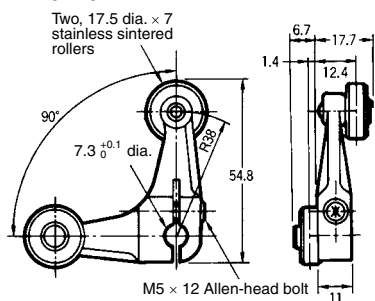
WL-5A101

WL-5A100 has a plastic roller

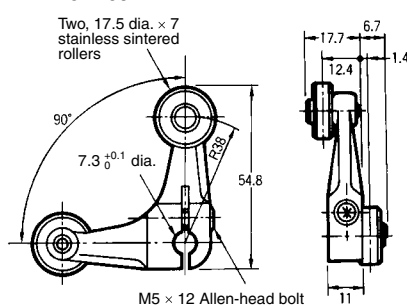



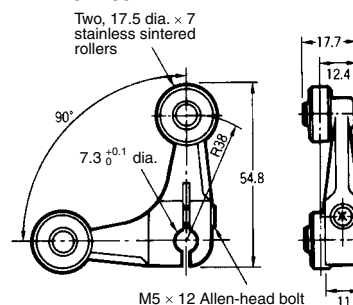

WL-5A103

WL-5A102 has a plastic roller

WL-5A105

WL-5A104 has a plastic roller

■ Head Models

Actuators	Set model	Head model	Head model without lever
Roller lever 	WLCA2	WL-1H1100	WLRCA2
	WLGCA2	WL-1H1100-1 (see note)	WLRGCA2
	WLG2	WL-2H1100	WLRG2
	WLH2	WL-2H1100-1 (see note)	WLRH2
	WLCA2-2N	WL-6H1100	WLRCA2-2N
Adjustable roller lever 	WLCA12	WL-1H2100	WLRCA2
	WLG12	WL-2H2100	WLRG2
	WLH12	WL-2H2100-1 (see note)	WLRH2
	WLCA12-2N	WL-6H2100	WLRCA2-2N
Adjustable rod lever 	WLCL	WL-4H4100	WLRCL
	WLGL	WL-2H4100	WLRG2
	WLCL-2N	WL-6H4100	WLRCA2-2N
Top plunger 	WLD	WL-7H100	---
	WLD2	WL-7H200	---
	WLD3	WL-7H300	---
	WLD28	WL-7H400	---
Horizontal plunger 	WLSD	WL-8H100	---
	WLSD2	WL-8H200	---
	WLSD3	WL-8H300	---
Fork lever lock 	WLCA32-41	WL-5H5100	WLRCA32
Coil spring 	WLNJ	WL-9H100	---
	WLNJ-30	WL-9H200	---
	WLNJ-2	WL-9H300	---
	WLNJ-S2	WL-9H400	---

Note: For the model number of Heads without lever, simply remove the numbers after WL-□H. For example, WL-1H1100 becomes WL-1H. WLH2 and WLH12 however, become WL-2H-1, and WLGCA2 becomes WL-1H-1. Other Head models are available, but must be ordered separately.

Environment-resistant Models

Spatter-prevention Models

These models are most effective in an arc welding line or places where cutting powder is spattered.



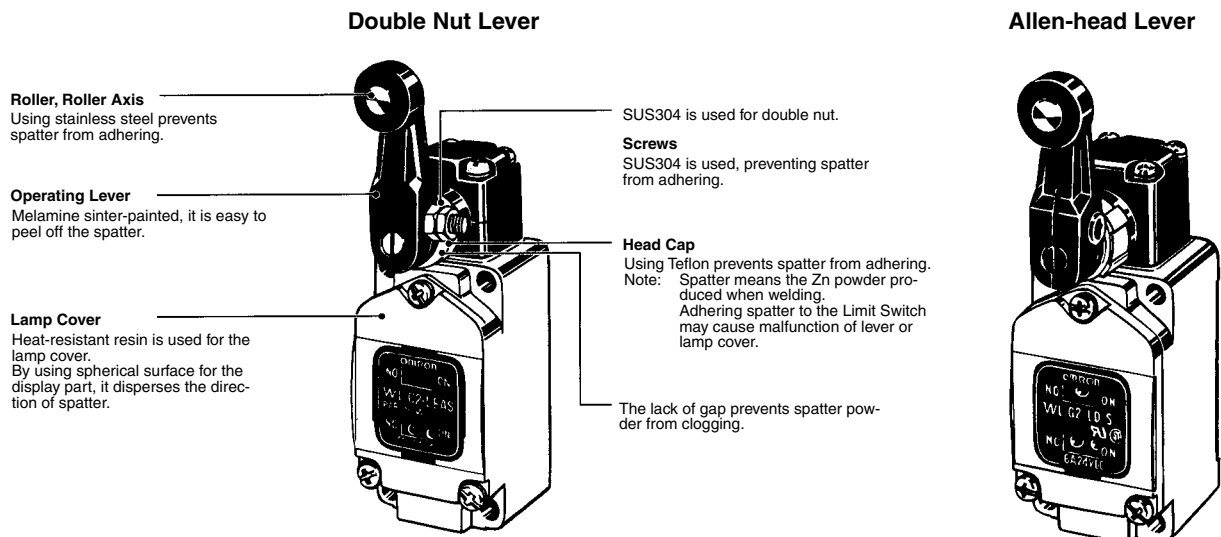

■ Nomenclature

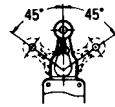

■ List of Models

Rotating Lever Models

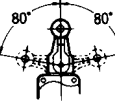
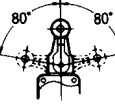
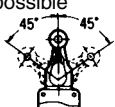
Standard Models

Type	Total travel (TT)	Actuators	Neon lamp		LED	
			125 VAC	250 VAC	10 to 115 VAC/DC	
			Approx. 0.6 mA	Approx. 1.9 mA	Approx. 1.0 mA	
Standard	One-side operation is possible 	Double nut lever 	WLCA2-LEAS		WLCA2-LDAS	
		Allen-head lever 	WLCA2-LES		WLCA2-LDS	
Over-travel	General One-side operation is impossible 	Double nut lever	WLH2-LEAS		WLH2-LDAS	
		Allen-head lever	WLH2-LES		WLH2-LDS	
	High-sensitivity	One-side operation is impossible 	Double nut lever	WLG2-LEAS		WLG2-LDAS
			Allen-head lever	WLG2-LES		WLG2-LDS
High-precision	One-side operation is possible 	Double nut lever 	WLGA2-LEAS		WLGA2-LDAS	
		Allen-head lever 	WLGA2-LES		WLGA2-LDS	

Note: Consult your OMRON representative for the microload WL01□ models.

Plunger Models

Standard Models

Actuator	Neon lamp		LED
	125 VAC	250 VAC	10 to 115 VAC/DC
	Approx. 0.6 mA	Approx. 1.9 mA	Approx. 1.0 mA
Seal top-roller plunger 	WLD28-LES		WLD28-LDS

■ Ratings

Model	Rated current	Non-inductive load				Inductive load			
		Resistive load		Lamp load		Inductive load		Motor load	
		NC	NO	NC	NO	NC	NO	NC	NO
WLCA2-LE□	125 VAC	10 A		3 A	1.5 A	10 A		5 A	2.5 A
WLH2-LE□	250 VAC	10 A		2 A	1 A	10 A		3 A	1.5 A
WLGCA2-LE□	125 VDC	0.8 A		0.2 A	0.2 A	0.8 A		0.2 A	0.2 A
WLG2-LE□	250 VDC	0.4 A		0.1 A	0.1 A	0.4 A		0.1 A	0.1 A
WLD28-LES	115 VAC	10 A		3 A	1.5 A	10 A		5 A	2.5 A
WLCA2-LD□	12 VDC	10 A		6 A	3 A	10 A		6 A	
WLH2-LD□	24 VDC	6 A		4 A	3 A	6 A		4 A	
WLGCA2-LD□	48 VDC	3 A		2 A	1.5 A	3 A		2 A	
WLG2-LD□									
WLD28-LD□									

- Note:**
1. The above figures are for standard currents.
 2. Inductive loads have a power factor of 0.4 min. (AC) and a time constant of 7 ms max. (DC).
 3. Lamp load has an inrush current of 10 times the steady-state current.
 4. Motor load has an inrush current of 6 times the steady-state current.

Inrush current	NC	30 A max.
	NO	20 A max.
Operating temperature	-10°C to 80°C (with no icing)	
Operating humidity	95% max.	

■ Contact Form

Standard Model

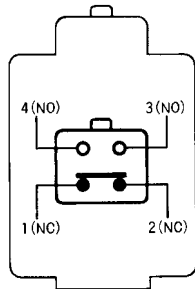

■ Approved Standard Ratings

UL/CSA

LE (Neon Lamp) A300

Rated voltage	Carry current	Current		Volt-amperes	
		Make	Break	Make	Break
120 VAC	10 A	60 A	6 A	7,200 VA	720 VA
240 VAC		30 A	3 A		

LD (LED)

Rated voltage	Carry current
115 VAC	10 A
115 VDC	0.8 A

■ Dimensions/Operating Characteristics

Roller Lever

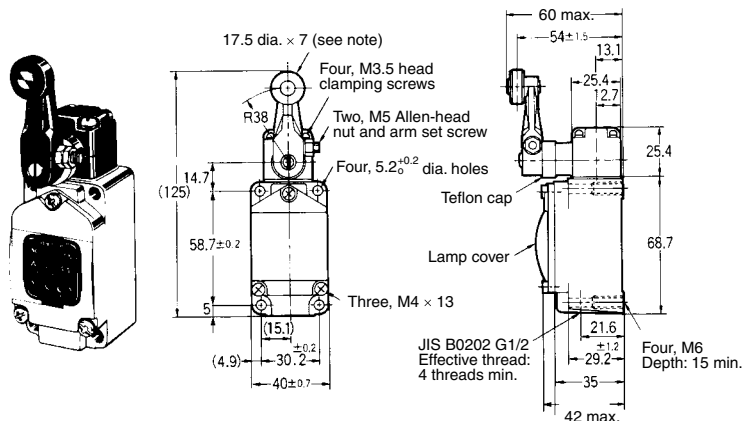

Note: Stainless steel roller

Operating characteristics	Standard	Overtravel models		High-precision
		General	High-sensitivity	
Operating force: OF max.	13.34 N	9.81 N	9.81 N	13.34 N
Release force: RF min.	2.23 N	0.98 N	0.98 N	1.47 N
Pretravel: PT	15°±5°	15°±5°	10° ^{+2°} _{-1°}	5° ^{+2°} _{-0°}
Overtravel: OT min.	30°	55°	65°	40°
Movement differential: MD max.	12°	12°	7°	3°

Seal Top-roller Plunger

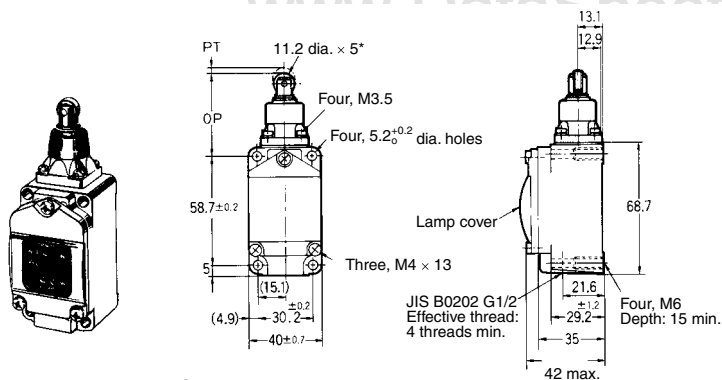

Note: Stainless steel roller





Operating characteristics	WLD28-L□S
Operating force: OF max.	16.67 N
Release force: RF min.	4.41 N
Pretravel: PT max.	1.7 mm
Overtravel: OT min.	5.6 mm
Movement differential: MD max.	1 mm
Operating position: OP	44±0.8 mm
Total travel position: TTP max.	39.5 mm

Note: Unless otherwise indicated, a tolerance of ±0.4 mm applies to all dimensions.

■ Spatter-prevention Parts

All parts of the Switch have spatter-prevention properties, so be sure to use the following products for maintenance of Spatter-prevention Limit Switches.

Levers/Lamp-equipped Covers

Type	Without lever 	Complete Head (lever with Head) 	Double nut lever 	Allen-head lever 	Lamp-equipped cover 
Model	Add an "R" to the product number to order. E.g.: WL□CA2-LES	WL-1H1100S (in case of WLCA2-□, WLGCA2-□) WL-2H1100S (in case of WLH2-□, WLG2-□)	WL-1A105S (forward and backward lever)	WL-1A103S (forward and backward lever)	WL-LES (Neon Lamp) WL-LDS (LED)

Switches Without Lever

WLRCA2-LES, WLRCA2-LDS
WLRH2-LES, WLRH2-LDS, WLRG2-LES
WLRG2-LDS
WLRGCA2-LES, WLRGCA2-LDS

Airtight, Hermetic Seal, Low-temperature, Heat-resistive, Corrosion-proof, and Weather-resistant Models

Using the general-purpose model, six types of environment-resistant models can be created to meet a variety of difficult operating conditions. Select the model most appropriate to your operating environment.

■ Nomenclature Example

Airtight Built-in Switch

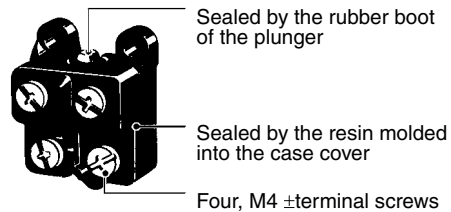

Hermetic Seal Model

The lead wires are sealed to the Limit Switch with resin, providing a hermetically sealed construction.

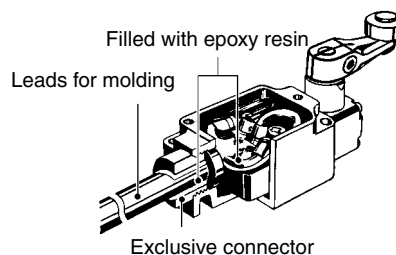

■ Models

Type		Usage	Environment-resistant construction			Appropriate models	
WL□-55	Airtight seal	For use in locations subject to splashes of water and anti-coolant	Uses the W-10FB3-55 Airtight Built-in Switch. (See note 2.)			All models except the low-temperature and heat-resistive models. (See note 3.)	
WL□-139	Hermetic seal (molded terminals and anti-coolant models)		General-purpose built-in switch	Connection lead wires: Standard 5-m VCT (vinyl cabtire cable) cable attached. Finished diameter: 11.5 mm, 4-core.	The case cover and conduit opening are molded from epoxy resin. The cover cannot be removed.	All models except the low-temperature and heat-resistive models. (See note 4.)	
WL□-140			Hermetically-sealed built-in switch	Connection lead wires: Standard 5-m VCT cable, with high flexibility and good anti-oil properties attached. Finished diameter: 11.5 mm, 4-core.	The case cover, cover box and conduit opening are molded from epoxy resin. The cover cannot be removed (140, 141, RP40, and RP60). The Head opening is protected from cutting powder. (WL□-141)		
WL□-141							
WL□-RP40							The connector can be removed, so it is possible to use flexible wires in the cable.
WL□-RP60							Rubber parts are made from fluorine rubber.
WL□-TC	Low-temperature	Can be used at a temperature of -40°C (The operating temperature range is -40°C to 40°C), but cannot withstand icing.	Uses the general-purpose built-in switch. Silicone rubber is used for rubber parts such as the O-ring, gasket, etc.			All models except airtight, hermetic, heat-resistive, corrosion-proof, or lamp-equipped models.	
WL□-TH	Heat-resistive	Can be used in temperatures of 120°C (The operating temperature range is 5°C to 120°C).	Uses a special built-in switch made from heat-resistant resin. Silicone rubber is used for rubber parts such as the O-ring, gasket etc.			All models except airtight, hermetic, low-temperature, corrosion-proof, lamp-equipped, nylon roller (WLCA2-26N), seal roller models, and resin rod (WLNJ-2) models.	
WL□-RP	Corrosion-proof	For use in locations subject to corrosive gases and chemicals.	Diecast parts such as the switch box are made of corrosion-proof aluminum. Rubber sealing parts are made of fluorine rubber which aids in resisting oil, chemicals and adverse weather conditions. Exposed nuts and screws (except the actuator section) are made of stainless steel. Moving and rotary parts such as rollers are made of sintered stainless steel or stainless steel.			All models except overtravel model (-2N), fork lever lock models (WLCA32-41 to -43), low-temperature, heat-resistive, and lamp-equipped models.	
WL□-P1	Outdoor specifications	For use in parking lots and other such outdoor locations.	Rubber parts are made from silicone rubber, which has a high-tolerance to deterioration over time, and changes in temperature. Rollers are made of stainless steel to improve corrosion resistance. Exposed nuts and screws are made of stainless steel.			Only the general-purpose overtravel models (WLH2/12), the overtravel high-sensitivity models (WLG2/12) and some standard models (e.g., WLCA2) can be used. Excluding heat-resistive models.	

- Note:**
1. Consult your OMRON representative for the microload WL01□ models.
 2. Use the SC Connector for the conduit opening.
 3. The actuator can be created using the standard model.
 4. The actuator can be created using the standard model. For WL-□141, only WLG2, WLCA2, and WLGCA2 can be used.

■ Dimensions/Operating Characteristics

The dimensions and operating characteristics are the same as general-purpose, environment-resistant models.

■ Ratings/Characteristics

See pages 38 to 41.

■ Contact Form

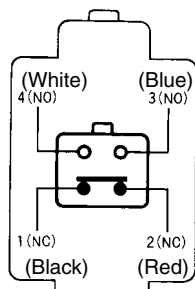

■ Approved Standard Ratings

Contact your OMRON representative for details of approved models.

■ Ordering Information

Use the following as a guide when ordering environment-resistant models.

E.g.: For a hermetic model of WLCA2

WLCA2 -	55
↑	↑
Standard	Specifications No.

An additional catalog is available for outdoor specifications models.

Lamp-equipped Models

The operating status of the Switch can be checked using a neon lamp or LED indicator.

Circuit checks and troubleshooting errors are easy done.

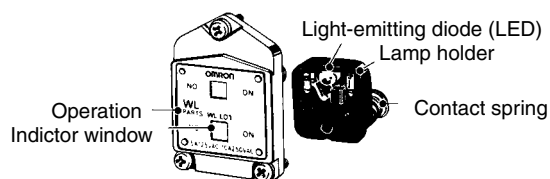

The built-in switch's terminal screws are used to connect the lamp terminal (indicator cover). Since the connection spring (coil spring) is used for this connection, it will not be necessary to connect to the lamp terminal. When a ground terminal is provided however, lead wire method must be used.

WL-LD has a built-in rectifier stack, so it will not be necessary to change the polarity.

The indicator cover is molded from diecast aluminum and has outstanding sealing properties. Furthermore, regardless of whether the power is connected or not, the operating status is shown (operating or not operating), and indicators can be

switched from light-ON when operating and light-ON when not operating, by simply rotating the lamp holder by 180°. (Molded terminals do not have this switching capacity.)

The lamp-equipped models are ideal in locations using a conveyor belt where items need to be checked, or locations that are difficult to inspect for faults.

Light-ON when Operating

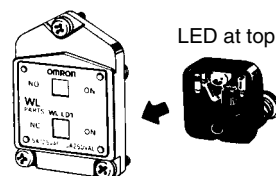

Light-ON when Not Operating

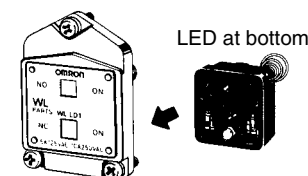

■ Models/Ratings

Operating characteristics	Rated voltage	Leakage current	Lamp-equipped Switch	Lamp-equipped cover only
Neon lamp	125 VAC	Approx. 0.6 mA	WL□-LE (see note 1.)	WL-LE
	250 VAC	Approx. 1.9 mA		
LED	10 to 115 VAC/VDC	Approx. 1 mA	WL□-LD (see note 1.)	WL-LD

Note: 1. In the model number, □ indicates the actuator number. For example, CA2, D, NJ, etc.

2. The default setting is "light-ON when not operating." Turn the lamp holder by 180° to change the setting to "light-ON when operating."

■ Operation

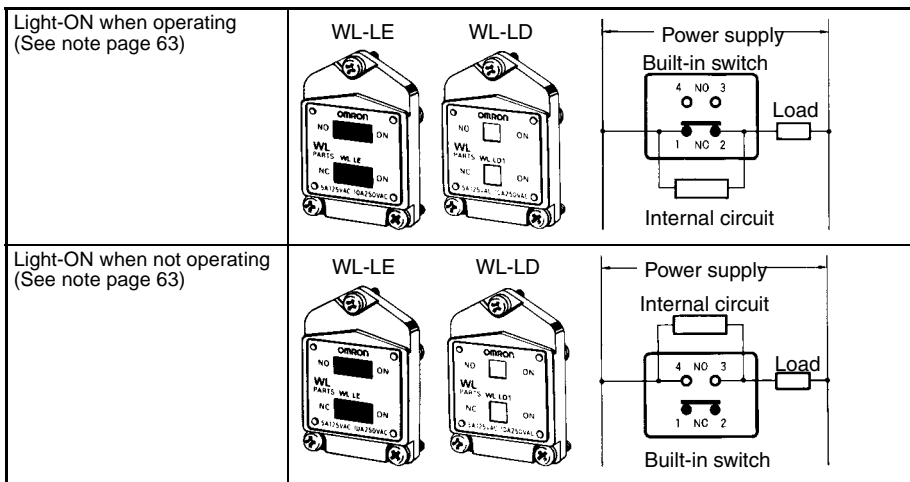

- Note:**
1. Light-ON when operating means that the lamp lights when the Limit Switch contacts (NC) release, or when the actuator rotates or is pushed down.
 2. Light-ON when not operating means the lamp remains lit when the actuator is free, or when the Limit Switch contacts (NO) close when the actuator rotates or is pushed down.

■ Ordering Information

When ordering general-purpose indicator-equipped models insert the specifications number at the end of the basic model number.
 E.g.: When a neon lamp is installed in a General-purpose/Standard Roller Lever Switch (WLCA2).

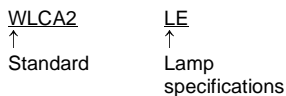

When ordering indicator-equipped molded terminal models, insert the specifications number at the end of the standard model number.
 E.g.: When a Neon Lamp (WL-LE) is installed in a general-purpose molded terminal model (WLCA2-139).

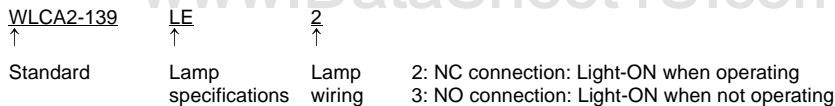

Note: The indicator cover cannot be replaced on the molded terminals. In all cases the indicator does not light when the load is ON.

■ Dimensions/Operating Characteristics

Roller Lever

WLCA2-LE

Note: Unless otherwise indicated, a tolerance of ±0.4 mm applies to all dimensions.

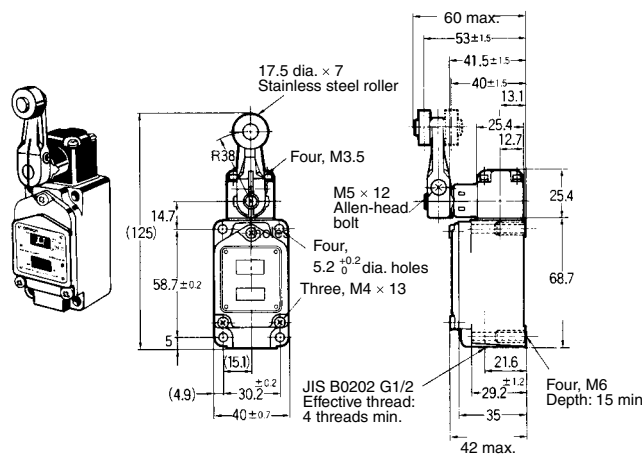

Note: Stainless steel roller

OF max.	13.34 N
RF min.	2.23 N
PT	15°±5°
OT min.	30°
MD max.	12°

■ Internal Circuits

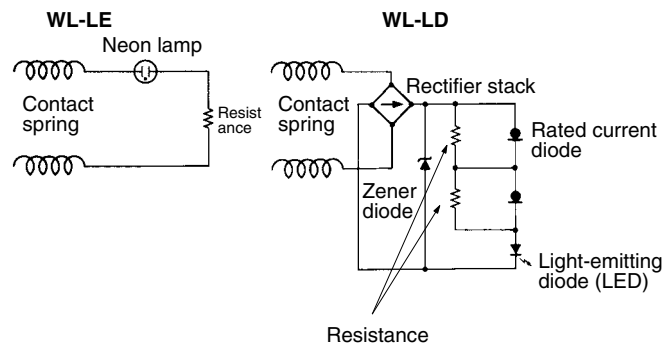

www.DataSheet4U.com

Sensor I/O Connector Models

A reduction in the amount of wiring and parts makes maintenance easy and reduced wiring mistakes, in addition it's already compact size for fitting into areas of limited space.

Ordering Information

Item		Standard	Overtravel	High sensitivity
Actuators	Rotating lever	Yes	Yes	Yes
	Plunger	Yes	---	---
Load	Standard load (SPST-NO/SPST-NC)	Yes		
	Microload (SPST-NO/SPST-NC)	Yes		
High-precision models WL-□55		Yes		
Spatter-prevention models (See note 3.)		Yes		
Lamp		Yes		

- Note:**
- Standard Models: For standard models only one-side operation at an angle of 45° is possible.
Overtravel Models: Only one-side operation at an angle of 80° is possible. One-side operation only is not possible.
High-precision Models: Only one-side operation at an angle of 45° is possible, and pretravel (PT) is 5°, as opposed to 15° for standard models.
 - For information other than that listed at the above, contact your OMRON representative.
 - The spatter-prevention models are only available as pre-wired connectors.

Models

Direct-wired Connectors

Type	2-core (NO)	4-core
Lamp-equipped	WL□-LDK13	WL□-LDK43
Double-seal	WL□-55LDK13	WL□-55LDK43

- Note:**
- In the model number, □ indicates the actuator number. For example, Overtravel Model WLG2-LDK13.
 - The lamp is set to "light-ON when not operating" (NO connection).

Pre-wired Connectors

Type	2-core (NO)	2-core (NC)	4-core	3-core (NO)
Lamp-equipped	WL□-LD-M1J	WL□-LD-M1JB	WL□-LD-DGJ03	WL□-LD-DK1EJ03
Double-seal	WL□-55LD-M1J	WL□-55LD-M1JB	WL□-55LD-DGJ3	WL□-55LD-DK1EJ03

- Note:**
- In the model number, □ indicates the actuator number. For example, Overtravel Model WLG2-LD-M1J.
 - The lamp is set to "light-ON when not operating" (NO connection).

Model Number Legend

WL - □ □ - □ LD □
 1 2 3 4

1. Electrical Rating

Blank: Standard
 01: Microload

2. Actuator Type

CA2: Roller lever: Standard
 GCA2: Roller lever: High-precision
 H2: Roller lever: Overtravel, general-purpose
 G2: Roller lever: Overtravel, high-sensitivity
 D2: Plunger: Top-roller plunger
 D28: Plunger: Top-roller plunger, sealed

3. Built-in Switch Type

Blank: Standard
 55: Hermetically sealed

4. Wiring Specifications

K13A: Direct-wired Connector
 (2-core: AC, NO wiring, connector pins No. 3, 4)
 K13: Direct-wired Connector
 (2-core: DC, NO wiring, connector pins No. 3, 4)
 K43A: Direct-wired Connector (4-core: AC)
 K43: Direct-wired Connector (4-core: DC)
 -M1J: Pre-wired Connector*
 (2-core: DC, NO wiring, connector pins No. 3, 4)
 -M1GJ: Pre-wired Connector*
 (2-core: DC, NO wiring, connector pins No. 1, 4)
 -M1JB: Pre-wired Connector*
 (2-core: DC, NC wiring, connector pins No. 3, 2)
 -AGJ03: Pre-wired Connector* (4-core, AC)
 -DGJ03: Pre-wired Connector* (4-core, DC)
 -DK1EJ03: Pre-wired Connector*
 (3-core: DC, NO wiring, connector pins No. 2, 3, 4)

Note: *With 0.3-m cable attached.

Direct-wired Connector

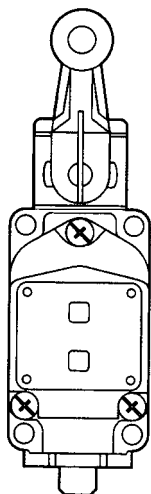

Pre-wired Connector

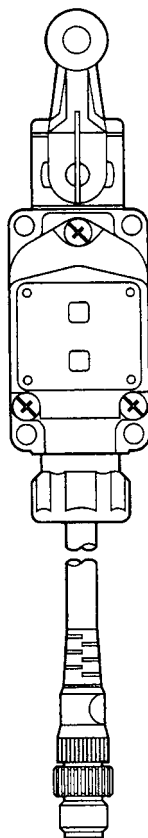

Spatter-prevention Models

WL - - S

1 2 3 4 5

1. Electrical Rating

Blank: Standard
01: Microload

2. Actuator Type

CA2: Roller lever: Standard
GCA2: Roller lever: High-precision
H2: Roller lever: Overtravel, general-purpose
G2: Roller lever: Overtravel, high-sensitivity
D28: Plunger: Top-roller plunger, sealed

3. Built-in Switch Type

Blank: Standard
55: Hermetically sealed

4. Indicator Lamp

Blank: None
LD: LED indicator lamp (AC/DC common)
LE: Neon Lamp

5. Wiring Specifications

-M1J-1: Pre-wired Connector*
(2-core: DC, NO wiring, connector pins No. 3, 4)
-M1GJ-1: Pre-wired Connector*
(2-core: DC, NO wiring, connector pins No. 1, 4)
-DGJS03: Pre-wired Connector* (4 core, DC)

Note: *With 0.3-m cable attached.

■ Wiring Specifications

Direct-wired Connector				Pre-wired Connector									
2-core		4-core		2-core						4-core		3-core	
K13 (DC) K13A (AC)		K43 (DC) K43A (AC)		M1J (DC)		M1GJ (DC)		M1JB (DC)		DGJ03 (DC) AGJ03 (AC)		DK1EJ03 (DC)	
Built-in switch	Con- nector	Built-in switch	Con- nector	Built-in switch	Con- nector	Built-in switch	Con- nector	Built-in switch	Con- nector	Built-in switch	Con- nector	Built-in switch	Con- nector
1 (NC)	---	1 (NC)	1	1 (NC)	---	1 (NC)	---	1 (NC)	3	1 (NC)	1	1 (NC)	---
2 (NC)	---	2 (NC)	2	2 (NC)	---	2 (NC)	---	2 (NC)	2	2 (NC)	2	2 (NC)	2
3 (NO)	3	3 (NO)	3	3 (NO)	3	3 (NO)	1	3 (NO)	---	3 (NO)	3	3 (NO)	3
4 (NO)	4	4 (NO)	4	4 (NO)	4	4 (NO)	4	4 (NO)	---	4 (NO)	4	4 (NO)	4

■ Ratings

General-purpose Ratings (Lamp-equipped)

Type	Rated voltage	Non-inductive load				Inductive load			
		Resistive load		Lamp load		Inductive load		Motor load	
		NC	NO	NC	NO	NC	NO	NC	NO
For DC	12 VDC	1 A	1 A	1 A	1 A	1 A	1 A	1 A	1 A
	24 VDC	1 A	1 A	1 A	1 A	1 A	1 A	1 A	1 A
	48 VDC	1 A	1 A	1 A	1 A	1 A	1 A	1 A	1 A
	115 VDC	0.8 A	0.8 A	0.2 A	0.2 A	0.8 A	0.8 A	0.2 A	0.2 A
For AC	115 VAC	1 A	1 A	1 A	1 A	1 A	1 A	1 A	1 A

- Note:**
- The above figures are for standard currents.
 - Inductive loads have a power factor of 0.4 min. (AC) and a time constant of 7 ms max. (DC).
 - Lamp load has an inrush current of 10 times the steady-state current.
 - Motor load has an inrush current of 6 times the steady-state current.

■ Dimensions

Roller Lever Models

Standard Model (WLCA2), High-precision Model (WLGCA2), Overtravel Model (WLH2), and Overtravel High-sensitivity Model (WLG2)

- Note:**
- For the WLG2 model, only the dimensions for the set position marker plate change.
 - Unless otherwise indicated, a tolerance of ± 0.4 mm applies to all dimensions.
 - The above diagram is for a lamp-equipped model.

Direct-wired Connector Models

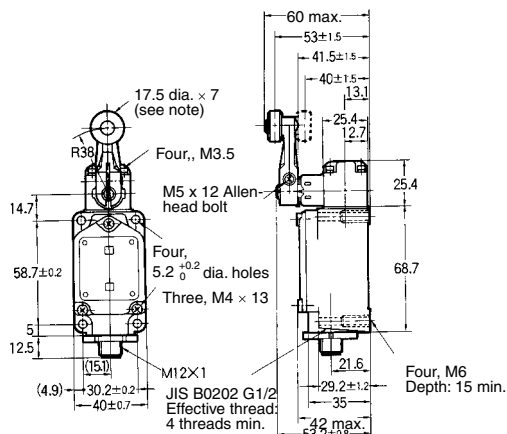

Note: Stainless sintered roller

Pre-wired Connector Models

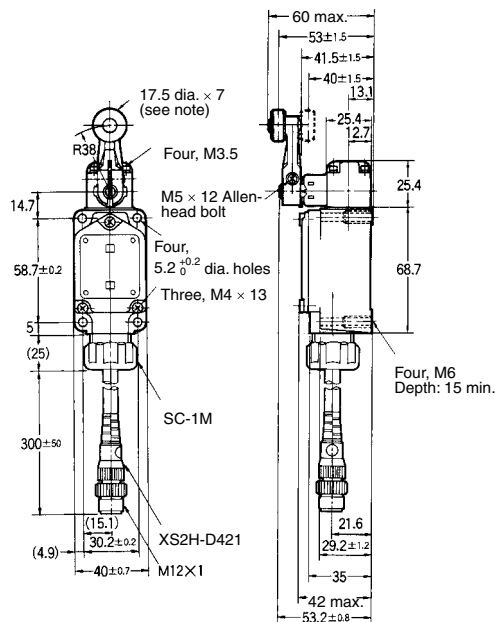

Operating characteristics	Roller lever/Standard model	Roller lever/High precision model	Roller lever/Overtravel model	Roller lever/Overtravel high sensitivity model
Operating force: OF max.	13.34 N	13.34 N	9.81 N	9.81 N
Release force: RF min.	2.23 N	1.47 N	0.98 N	0.98 N
Pretravel: PT	15±5°	5 ^{+2°} _{-0°}	15±5°	10 ^{+2°} _{-1°}
Overtravel: OT min.	30°	40°	55°	65°
Movement differential: MD max.	12°	3°	12°	7°

Top-roller Plunger

WLD2

- Note:** 1. Unless otherwise indicated, a tolerance of ± 0.4 mm applies to all dimensions.
2. The above diagram is for a lamp-equipped model.

Direct-wired Connector Models

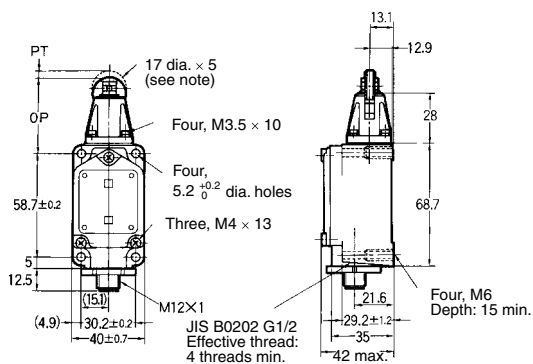

Note: Stainless sintered roller

Pre-wired Connector Models

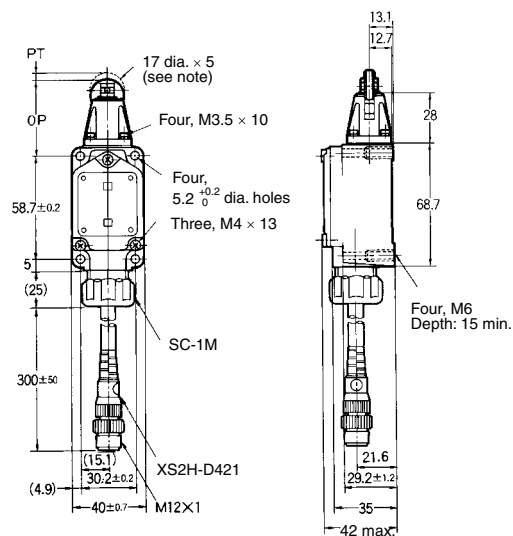

Operating characteristics	Top-roller plunger actuator
Operating force: OF max.	26.67 N
Release force: RF min.	8.92 N
Pretravel: PT max.	1.7 mm
Overtravel: OT min.	5.6 mm
Movement differential: MD max.	1 mm
Operating position: OP	44 ± 0.8 mm
Total travel position: TTP max.	39.5 mm

Sealed Top-roller Plunger

WLD28

- Note:** 1. Unless otherwise indicated, a tolerance of ± 0.4 mm applies to all dimensions.
2. The above diagram is for a lamp-equipped model.

Direct-wired Connector Models

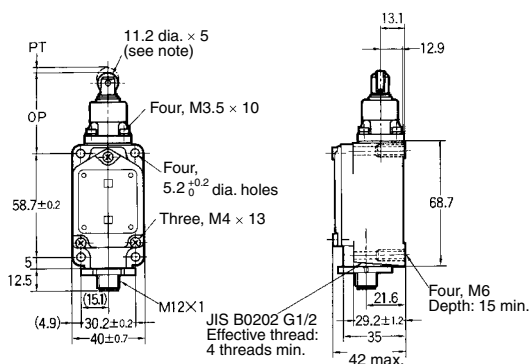

Note: Stainless sintered roller

Pre-wired Connector Models

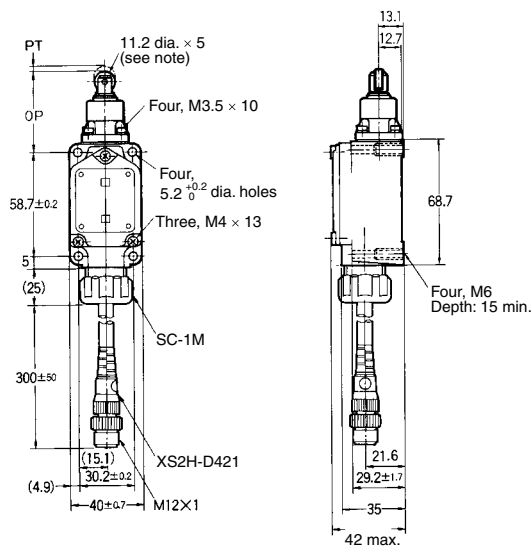

Operating characteristics	Sealed top-roller plunger actuator
Operating force: OF max.	16.67 N
Release force: RF min.	4.41 N
Pretravel: PT max.	1.7 mm
Overtravel: OT min.	5.6 mm
Movement differential: MD max.	1 mm
Operating position: OP	44 ± 0.8 mm
Total travel position: TTP max.	39.5 mm

■ Application Variations

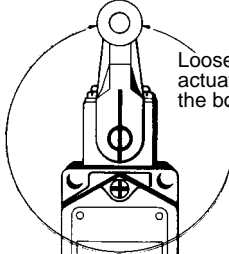
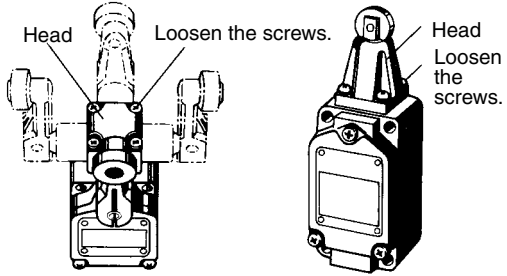
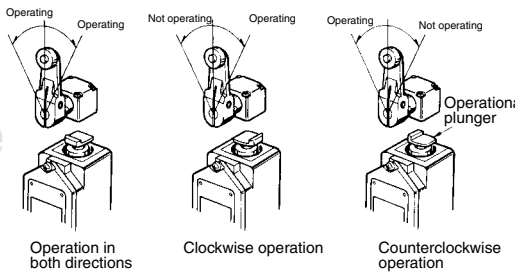
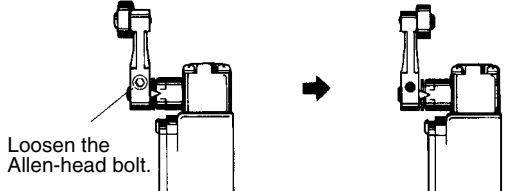
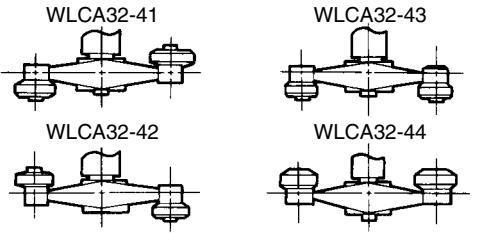
Item	Appropriate model/actuator	Details
<p>Changing the installation position of the actuator</p> <p>By loosening the Allen-head bolt on the actuator lever, the position of the actuator can be set anywhere within the 360°. With Lamp-equipped Switches, the actuator lever comes in contact with the top of the lamp cover, so use caution when rotating and setting the lever. When the lever only moves forwards and backwards, it will not contact the lamp cover.</p>	<p>Roller Levers: WLCA2, WL01CA2, WLH2, WL01H2, WLG2, WL01G2</p> <p>Adjustable Roller Levers: WLCA12, WL01CA12, WLH12, WL01H12, WLG12, WL01G12</p> <p>Adjustable Rod Levers: WLCL, WL01CL, WLHL, WL01HL, WLGL, WL01GL</p>	 <p>Loosen the M5 · 12 bolt, set the actuator's position and then tighten the bolt again.</p>
<p>Changing the orientation of the Head</p> <p>By removing the screws in the four corners of the Head, the Head can be set in any of the four directions. Be sure to change the plunger for internal operations at the same time. (The operational plunger does not need to be changed on overtravel general-purpose and high-sensitivity models.) The roller plunger can be set in either two positions at 90°. WLCA2-2N and WL01CA2-2N can only be set in either the forward or backward direction.</p>	<p>Roller Levers: WLCA□, WL01CA□, WLGCA□</p> <p>Adjustable Rod Levers: WLCL, WL01CL</p> <p>Horizontal Plungers: WLSD□, WL01SD□</p> <p>Roller Plungers: WLD2, WL01D2</p> <p>Sealed Roller Plungers: WLD28, WL01D28.</p> <p>Note: Does not include -RP60 Series or -141 Series.</p>	 <p>Head Loosen the screws.</p> <p>Head Loosen the screws.</p>
<p>Changing the operating direction</p> <p>By removing the Head on models which can operate on one-side only, and then changing the direction of the operational plunger, one of three operating directions can be selected. In the case of overtravel models, as noted on page 51, by loosening the rubber holder using either a coin or a flat-blade screwdriver, and changing the direction of the internal rubber section, one of three operating directions can be selected.</p> <p>The tightening torque for the screws on the Head is 0.78 to 0.88 N · m. (8 to 9 kg · cm)</p>	<p>Roller Levers: WLCA□, WL01CA□</p> <p>Adjustable Roller Levers: WLCA12, WL01CA12</p> <p>Adjustable Rod Levers: WLCL, WL01CL</p> <p>Overtravel Models: WLCA□-2N, WL01CA□-2N</p> <p>Note: The diagram at the right is not correct for the overtravel -2N models.</p>	<p>The output of the Switch will be changed, regardless of which direction the lever is pushed.</p> <p>The output of the Switch will only be changed when the lever is pushed in one direction.</p>  <p>Operating Not operating Operating Operating Not operating</p> <p>Operational plunger</p> <p>Operation in both directions Clockwise operation Counterclockwise operation</p> <p>For details on overtravel -2N models, refer to page 50.</p>
<p>Installing the roller on the inside</p> <p>By installing the roller lever in the opposite direction, the roller can be installed on the inside. (Set so that operation can be completed within a 180° level range.)</p>	<p>Roller Levers: WLCA□, WL01CA□, except for the adjustable roller levers.</p> <p>Fork Lever Locks: WLCA32-4□, WL01CA32-4□</p>	 <p>Loosen the Allen-head bolt.</p>
<p>Selecting the roller position</p> <p>There are four types of fork lever lock for use depending on the roller position.</p>	<p>Fork Lever Locks: WLCA32-4□, WL01CA32-4□</p>	 <p>WLCA32-41 WLCA32-43</p> <p>WLCA32-42 WLCA32-44</p>

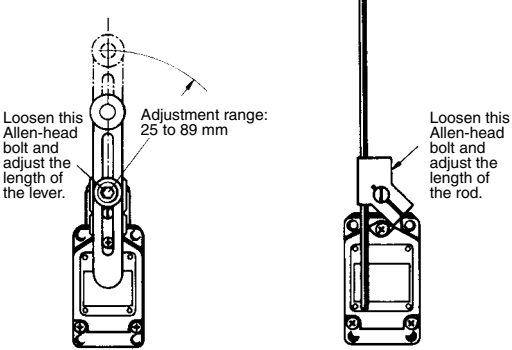
Item	Appropriate model/actuator	Details
<p>Adjusting the length of the rod or lever</p> <p>The length of the rod or lever can be adjusted by loosening the Allen-head bolt.</p>	<p>Adjustable Roller Levers: WLCA12, WL01CA12 etc.</p> <p>Adjustable Rod Levers: WLCL, WL01CL etc.</p>	<p>WLCA12 etc.</p>  <p>Loosen this Allen-head bolt and adjust the length of the lever.</p> <p>Adjustment range: 25 to 89 mm</p> <p>Loosen this Allen-head bolt and adjust the length of the rod.</p>

Precautions

Cautions

When a rod or wired-type actuator is used, do not touch the top end of the actuator. Doing so may result in injury.
Applicable models: WLHAL5 and WL01HAL5 Rod Spring Levers and WLNJ-S2 and WL01NJ-S2 Steel-wire Actuators.

Correct Use

A short-circuit may cause damage to the Switch, so insert a circuit breaker fuse, of 1.5 to 2 times the rated current, in parallel with the Switch. In order to meet EN approval ratings, use a 10-A fuse that corresponds to IEC269, either a gI or gG.

When wiring terminal screws, use M4 round crimp terminals and tighten screws to the recommended torque. Wiring with broken wires, or the incorrect crimp terminals, or not tightening screws to the recommended torque can lead to short-circuits, leakage current, and fire.

When performing internal wiring there is a chance of short-circuit, leakage current, or fire, so be sure to protect the inside of the Switch from splashes of oil or water, corrosive gases, and cutting powder.

Using an inappropriate connector or assembling Switches incorrectly (assembly, tightening torque) can result in malfunction, leakage current, or fire, so be sure to read the instruction manual thoroughly beforehand.

Even when the connector is assembled and set correctly, the end of the cable and the inside of the Switch may come in contact. This can lead to malfunction, leakage current, or fire, so be sure to protect the end of the cable from splashes of oil or water and corrosive gases.

Environmental Precautions

When the Switch is used in locations subject to splashes of water or oil, the material of the seal, which ensures the sealing properties of the Switch, may undergo changes in shape and quality. This is due to deterioration (including expansion and contraction), and may result in reduced performance, ineffective return, and ineffective sealing (leading to ineffective contact, insulation, leakage current, and fire). Confirm the possible effects of the operating environment on the Switch before use.

Built-in Switch

Do not remove or replace the built-in switch. If the position of the built-in switch moves, it can cause reduced performance, and if the insulation sheet moves (separator), the insulation may become ineffective.

Correct Tightening Torque

If screws are too loose they can lead to an early malfunction of the Switch, so ensure that all screws are tightened using the correct torque.

No.	Type	Torque
①	Head mounting screw	0.78 to 0.88 N • m
②	Cover mounting screw	1.18 to 1.37 N • m
③	Allen-head bolt (for securing the lever)	4.90 to 5.88 N • m
④	Terminal screw	0.59 to 0.78 N • m
⑤	Connector	1.77 to 2.16 N • m
⑥	Main Unit screws	4.90 to 5.88 N • m

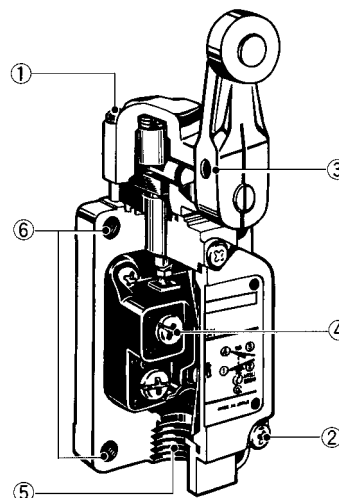

In particular, when changing the direction of the Head, make sure that all screws are tightened again to the correct torque. Do not allow foreign objects to fall into the Switch.

Installing the Switch

To install the Switch, make a mounting panel, as shown in the following diagram, and tighten screws using the correct torque.

Standard/Overtravel model	Overtravel model (side installation)
<p>Mounting holes</p> <p>Four, $5.2^{+0.2}_0$ dia. holes</p>	<p>Mounting holes</p> <p>Two, $5.2^{+0.2}_0$ dia. holes</p>

Connectors

Either the easy-to-use Allen-head nut or the SC Connector can be used as connectors. To ensure high-sealing properties, use the SC Connector. (Refer to page 25 to 28.) (SC-1M to -5M and others.)

Wiring

Use 1.25-mm lead wires and M4-insulation covered crimp terminals for wiring.

Crimp Terminal External Dimensions

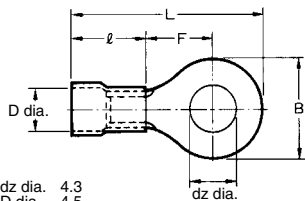

dz dia.	4.3
D dia.	4.5
B:	8.5
L:	21.0
F:	7.8
dz	9.0 (mm)

Wiring Method

Switch Box Section

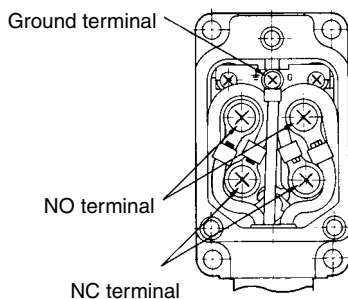

Note: The ground terminal is only installed on models with ground terminals.

Rotating Lever Set Position

All rotating lever models, except the fork lever lock, have a set position marker plate. (See page 38.) After operation, set the indicator needle on the marker plate so that is in the convex section of the bearing.

Terminal Plate

By using a short circuit plate, as shown in the following diagram, the Switch can be fabricated into a single-polarity double-break model. When ordering specify WL Terminal Plate (product code: WL-9662F).

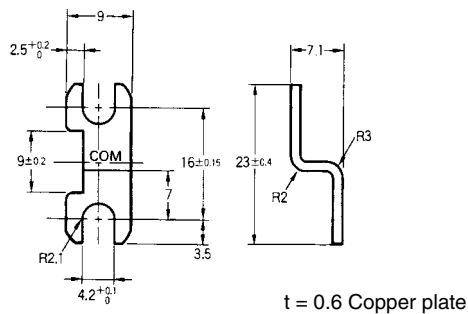

www.DataSheet4U.com

ALL DIMENSIONS SHOWN ARE IN MILLIMETERS.

To convert millimeters into inches, multiply by 0.03937. To convert grams into ounces, multiply by 0.03527.

Cat. No. C001-E1-12