

802.11b/g/n + BT2.1 + FM Radio 3 in One SiP Module



Data Sheet Setp 23 2009 Rev 2.3

www.usi.com.tw

Product Requirement of WM-BN-BM-01 WLAN +BT+FM 3 in One Module

CONFIDENTIAL

All rights are reserved by USI. No part of this technical document can be reproduced in any form without permission of USI

802.11b/g/n Wireless LAN + BT + FM 3 in One SiP Module V2.3

Introduction

The 802.11b/g/n + BT + FM receiver Wireless SiP module WM-BN-BM-01 which refers as “SiP 3 in One module” is a small size module that provides full function of 802.11b/g/n (draft n), Bluetooth class 2.1 and FM Receiver in a tiny module via 66 pins LGA Foot Print.

This multi- functionality and board to board physical interface provides SDIO/SPI interface for WiFi, UART for Bluetooth and FM transceiver.

The small size & low profile physical design make it easier for system design to enable high performance wireless connectivity without space constrain. The low power consumption and excellent radio performance make it the best solution for OEM customers who require embedded 802.11b/g/n Wi-Fi + Bluetooth features, such as, Wireless PDA, Smart phone, MP3, PMP, slim type Notebook, VoIP phone etc.

The module is based on Broadcom 4329 chipset which is a WiFi+BT+FM Transceiver SOC. The Radio architecture & high integration MAC/BB chip provide excellent sensitivity with rich system performance. The module is designed as single antenna for WiFi and Bluetooth for the application of small size hand held device.

In addition to WEP 64/128, WPA and TKIP, AES, CCX is supported to provide the latest security requirement on your network.

For the software and driver development, USI provides extensive technical document and reference software code for the system integration under the agreement of Broadcom International Ltd.

Hardware evaluation kit and development utilities will be released base on listed OS and processors to OEM customers.

Features

- Lead Free design which supporting Green design requirement, RoHS Compliance.
- The module can support Halogen Free
- Support single Antenna for WiFi and Bluetooth
- Small size suitable for low volume system integration.
- Low power consumption & excellent power management performance extend battery life.
- 2.412-2.484 GHz two SKUs for worldwide market.
- Easy for integration into mobile and handheld device with flexible system configuration and antenna design.
- Supports per packet Rx Antenna diversity



802.11b/g/n Wireless LAN + BT + FM 3 in One SiP Module V2.3

Change Sheet					
Rev.	Date	Description of change			Approval & Date
		Page	Par	Change(s)	
1.0	04/20/09	All	All	Draft version for Review	Jason Tsai
1.1	06/10/09	11,29		BT spec update Recommended Footprint update	Jason Tsai
1.3	07/01/09	All	5.2, 5.3	Power consumption, add Power topology for WM-BN-BM-01, update WLAN specific	Jason Tsai
1.4	07/27/09	11,12,29	5.4, 5.6, 8	WLAN spect update: power level of 11n change to 17dBm, BT spec update: sensitivity change to -88dBm as typical, update module top view	Jason Tsai
1.5	08/28/09	2, 9,10, 11,12,29	5.2.1, 5.2.2,5.4, 5.6	Add Halogen Free, Operation voltage, power consumption, WLAN RX spec, BT maximum input level, remove FM RX spec,	Jason Tsai
2.0	09/22/09	35	10.4	Add life cycle	Jason Tsai
2.1	10/15/09	11	5.4	Add hint for CE and FCC requirement	Jason Tsai
2.2	11/25/09	35	10.4	Add the Half-Sine Shock	Jason Tsai/Scarrie
2.3	12/11/09	6, 13	2, 5.7	Update Block Diagram Update Reference Circuit	Jason Tsai/Scarrie

TABLE OF CONTENTS

1. EXECUTIVE SUMMARY	5
2. BLOCK DIAGRAM	6
3. DELIVERABLES	7
4. REFERENCE DOCUMENTS	8
5. TECHNICAL SPECIFICATION	9
5.1. ABSOLUTE MAXIMUM RATING.....	9
5.2. RECOMMENDABLE OPERATION CONDITION.....	9
5.2.1. TEMPERATURE, HUMIDITY	9
5.2.1. VOLTAGE	9
5.3. WIRELESS SPECIFICATIONS	11
5.4. RADIO SPECIFICATIONS 802.11B/G/N.....	11
5.5. RADIO SPECIFICATIONS 802.15 BLUETOOTH.....	12
5.6. BLUETOOTH RADIO CHARACTERISTICS.....	12
5.7. FM SPECIFICATIONS	12
5.8. TIMING DIAGRAM OF INTEFACE.....	14
5.9. DIMENSIONS, WEIGHT AND MOUNTING.....	25
5.9.1. DIMENSIONS.....	25
6. LEGAL, REGULATORY & OTHER TECHNICAL CONSTRAINTS	25
7. PIN OUT AND PIN DESCRIPTION	26
8. RECOMMEND FOOTPRINT	30
9. RECOMMENDED REFLOW PROFILE	31
10. PACKAGE AND STORAGE CONDITION	32

CONFIDENTIAL

802.11b/g/n Wireless LAN + BT + FM 3 in One SiP Module V2.3

1. EXECUTIVE SUMMARY

The WM-BN-BM-01 module - is one of the product families in USI's product offering, targeting for system integration requiring a smaller form factor. It also provides the standard migration to high data rate to USI's current SIP customers.

The purpose of this document is to define the product specification for 802.11b/g/n (draft n) WiFi + BT 2.1 +FM module WM-BN-BM-01. **All the data in this document is based on Broadcom 4329 data sheet and other documents provided from Broadcom. The data will be updated after implementing the measurement of the module.**

This product is designated for use in embedded applications mainly in the mobile device, which required small size and high data rate wireless connectivity. The application such as, Wireless PDA, slim type Notebook, Media Adapter, Barcode scanner, mini-Printer, VoIP phone, Data storage device could be the potential application for wireless WM-BN-BM-01.

CONFIDENTIAL

802.11b/g/n Wireless LAN + BT + FM 3 in One SiP Module V2.3

2. BLOCK DIAGRAM

The WM-BN-BM-01 module is designed based on Broadcom 4329 chipset solution. It supports generic SPI (G-SPI), SDIO interface to connect the WLAN to the host processor. High speed UART is available to connect the Bluetooth2.1 + EDR and FM to the host processor. A Bluetooth co-existence interface is supported for external, co-located Bluetooth devices. Antenna diversity should add one SPDT switch outside module and control by module.

A simplified block diagram of the WM-BN-BM-01 module is depicted in the Fig. below.

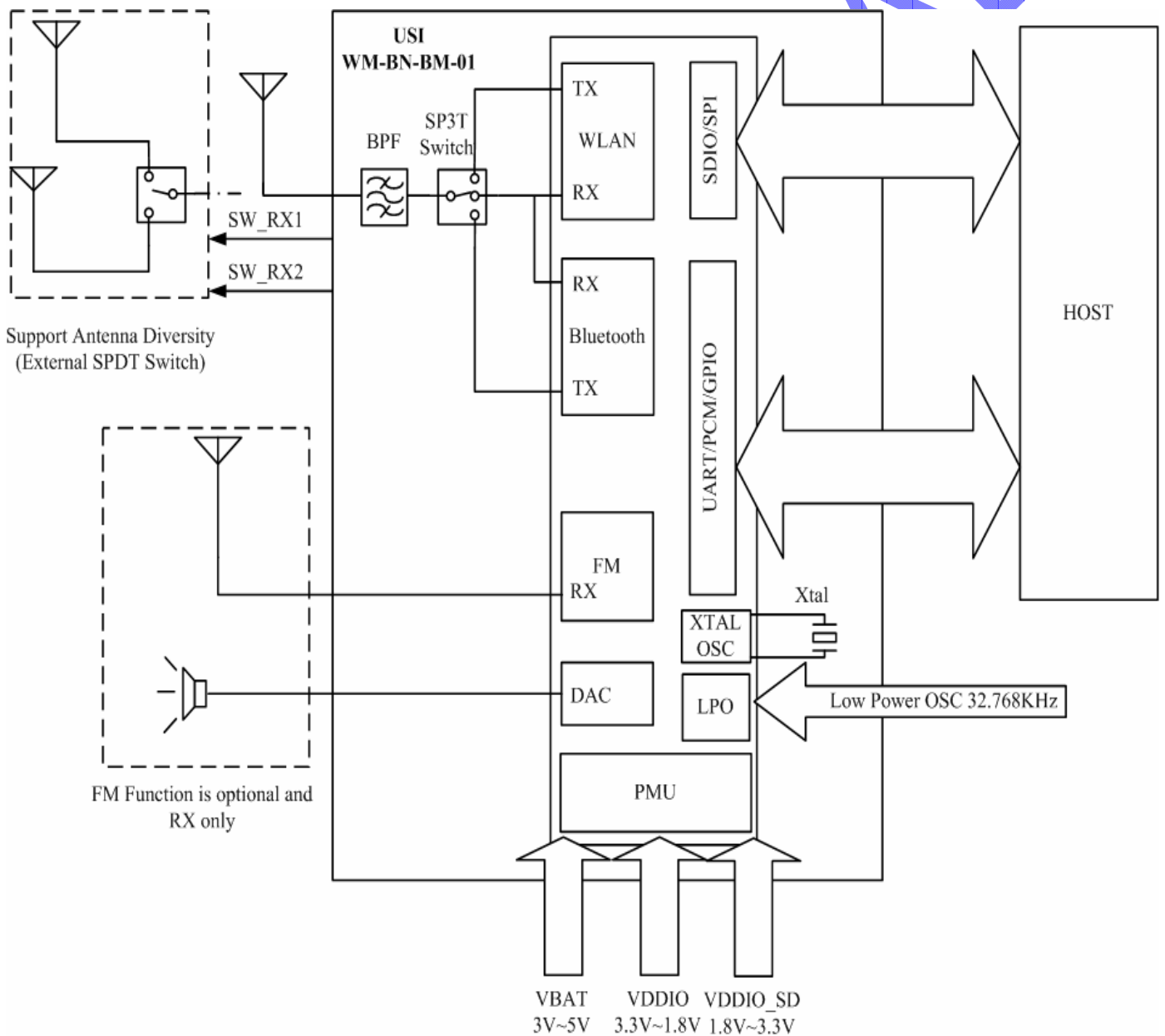

802.11b/g/n Wireless LAN + BT + FM 3 in One SiP Module V2.3

3. DELIVERABLES

The following products and software will be part of the product.

- ✚ WM-BN-BM-01 Module with packaging
- ✚ Evaluation kits (with SDIO / SPI interface)
- ✚ Software utility which supporting customer for integration, performance test and homologation. Capable of testing, loading (firmware) and configuring (MAC, CIS) for the WM-BN-BM-01 module.
- ✚ Unit Test / Qualification report
- ✚ Product Specifications.
- ✚ Agency certification pre-test report base on adapter boards

CONFIDENTIAL

802.11b/g/n Wireless LAN + BT + FM 3 in One SiP Module V2.3

4. REFERENCE DOCUMENTS

C.I.S.P.R. Pub. 22	"Limits and methods of measurement of radio interference characteristics of information technology equipment." International Special Committee on Radio Interference (C.I.S.P.R.), Third Edition, 1997.
CB Bulletin No. 96A	"Adherence to IEC Standards: "Requirements for IEC 950, 2 nd Edition and Amendments 1 (1991), 2(1993), 3 (1995) and 4(1996). Product Categories: Meas, Med, Off, Tron." IEC System for Conformity Testing to Standards for Safety of Electrical Equipment (IECEE), April 2000.
CFR 47, Part 15-B	"Unintentional Radiators". Title 47 of the Code of Federal Regulations, Part 15, FCC Rules, Radio Frequency Devices, Subpart B.
CFR 47, Part 15-C	"Intentional Radiators". Title 47 of the Code of Federal Regulations, Part 15, FCC Rules, Subpart C. URL: http://www.access.gpo.gov/nara/cfr/waisidx_98/47cfr15_98.html
CSA C22.2 No. 950-95	"Safety of Information Technology Equipment including Electrical Business Equipment, Third Edition." Canadian Standards Association, 1995, including revised pages through July 1997.
EN 60 950	"Safety of Information Technology Equipment Including Electrical Business Equipment." European Committee for Electrotechnical Standardization (CENELEC), 1996, (IEC 950, Second Edition, including Amendment 1, 2, 3 and 4).
IEC 950	"Safety of Information Technology Equipment Including Electrical Business Equipment." European Committee for Electrotechnical Standardization, Intentional Electrotechnical Commission. 1991, Second Edition, including Amendments 1, 2, 3, and 4.
IEEE 802.11	"Wireless LAN Medium Access Control (MAC) And Physical Layer (PHY) Specifications." Institute of Electrical and Electronics Engineers. 1999.

802.11b/g/n Wireless LAN + BT + FM 3 in One SiP Module V2.3

5. TECHNICAL SPECIFICATION

5.1. ABSOLUTE MAXIMUM RATING

Supply Power	Max +3.6 Volt	
Non Operating Temperature	- 40° to 85° Celsius	
Voltage ripple	+/- 2%	Max. Values not exceeding Operating voltage

5.2. RECOMMENDABLE OPERATION CONDITION

5.2.1. TEMPERATURE, HUMIDITY

The WM-BN-BM-01 module has to withstand the operational requirements as listed in the table below.

Operating Temperature	-20° to 70° Celsius	
Humidity range	Max 95%	Non condensing, relative humidity

5.2.1. VOLTAGE

Power supply for the WM-BN-BM-01 module will be provided by the host via the power pins

Symbol	Parameter	Min	Typ	Max	Unit
VBAT	3.3V Power Supply	2.8 ^a	3.3	5.0	V
VDDIO^b	Host Interface Power Supply	1.62	1.8	1.98	V
		2.97	3.3	3.63	V
VDDIO_SD	Host Interface Power Supply	1.62	1.8	1.98	V
		2.97	3.3	3.63	V

- ◆ a: 2.8V is the minimum voltage to keep PA performance of TX path
- ◆ b: I/O interface DC level depends on VDDIO

802.11b/g/n Wireless LAN + BT + FM 3 in One SiP Module V2.3

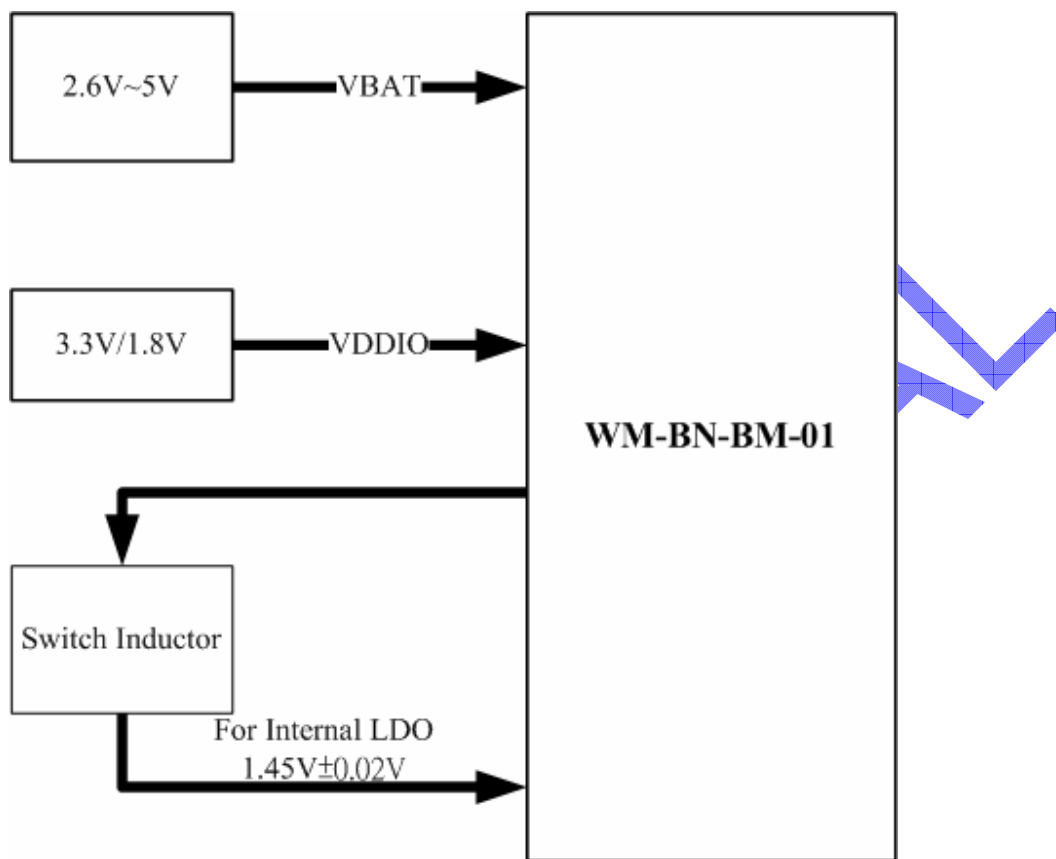

Power Topology of WM-BN-BM-01

5.2.2. Power consumption

Power consumption		Typical	Max
WiFi	Tx @ 17dBm output power @ 25C (11b)	275mA	290mA
	Tx @ 17dBm output power @ 25C (11g)	220mA	270mA
	TX@17dBm output power @ 25C (11n)	220mA	270mA
	Rx @25C (11b)	77mA	90mA
	Rx @25C (11g)	77mA	90mA
BT	Tx @ 10dBm output power @ 25C	50mA	60mA
	Rx (multi-sensitivity)@25C	40mA	50mA

Condition: VBAT=3.6V, VDDIO=3.3V, WL_BT_REG_ON=H, WL_RST_ON=H, BT_RST_ON=H

802.11b/g/n Wireless LAN + BT + FM 3 in One SiP Module V2.3

5.3. WIRELESS SPECIFICATIONS

The WM-BN-BM-01 module complies with the following features and standards;

Features	Description
WLAN Standards	IEEE 802 Part 11b/g/n (802.11b/g/n ^a)
Bluetooth	Bluetooth™ 2.1 compliance
Antenna Port	Support Single Antenna for WiFi and BT
Frequency Band	2.400 GHz – 2.484 GHz

◆ a: 802.11n in this module only support HT20

5.4. RADIO SPECIFICATIONS 802.11B/G/N

Features	Description
Frequency Band	2.4000 GHz – 2.497 GHz (2.4 GHz ISM Band)
Number of selectable Sub channels	14 channels
Modulation	OFDM, DSSS (Direct Sequence Spread Spectrum), DBPSK, DQPSK, CCK, 16QAM, 64QAM
Supported rates	1,2, 5.5,11,6,9,12,24,36,48,54 Mbps
Maximum receive level	-10dBm (with PER < 8%)
Output Power	17 dBm +2.0/-2.0 dBm for 802.11b 15 dBm +2.0/-2.0 dBm for 802.11g 15 dBm +2.0/-2.0 dBm for 802.11n
Wide-Band Noise	-160 dBm/Hz (max.)@869 MHz~960 MHz -160 dBm/Hz (max.)@1800 MHz~1990 MHz -154 dBm/Hz (max.)@2110 MHz~2170MHz

Hint: For CE request, 17dB can pass the test, For FCC request, it needs lower power to 15dBm to pass the test only in channel 1 effect 2390MHz in 11n HT20

Receiver Characteristics (3.3V, 25 degree C)	Typical	Max.	Unit
PER <8%, Rx Sensitivity @ 1 Mbps	-94	-92	dBm
PER <8%, Rx Sensitivity @ 11 Mbps	-88	-86	dBm
PER <10% Rx Sensitivity @ 6 Mbps	-88	-86	dBm
PER <10%, Rx Sensitivity @ 54 Mbps	-74	-73	dBm
PER <10%, Rx Sensitivity @ MCS0	-90	-87	dBm
PER <10%, Rx Sensitivity @ MCS7	-72	-71	dBm

All rights are reserved by USI. No part of this technical document can be reproduced in any form without permission of USI

802.11b/g/n Wireless LAN + BT + FM 3 in One SiP Module V2.3

5.5. RADIO SPECIFICATIONS 802.15 BLUETOOTH

The Radio specification is compliant with the Bluetooth™ 2.1 + EDR specification

Features	Description
Frequency Band	2400 MHz ~ 2483.5 MHz
Number of Channels	79 channels
Modulation	FHSS (Frequency Hopping Spread Spectrum) , GFSK
Antenna Port	Single Antenna for WiFi and BT

5.6. BLUETOOTH RADIO CHARACTERISTICS

Features	Description		
	Max.	Typical	Min.
Maximum Receive Level	-	-	-20dBm
Output Power	15dBm	10.5dBm	9.5dBm
Sensitivity	-87dBm	-88 dBm	-90dBm
EDR Sensitivity	-80dBm	-82dBm	-85dBm
Wide-Band Noise	-160 dBm/Hz (max.)@869 MHz~960 MHz -160 dBm/Hz (max.)@1800 MHz~1990 MHz -154 dBm/Hz (max.)@2110 MHz~ 2170MHz		

5.7. FM SPECIFICATIONS

FM RX

TBD

802.11b/g/n Wireless LAN + BT + FM 3 in One SiP Module V2.3

5.8. TIMING DIAGRAM OF INTEFACE CONTROL SIGNAL TIMING DIAGRAMS

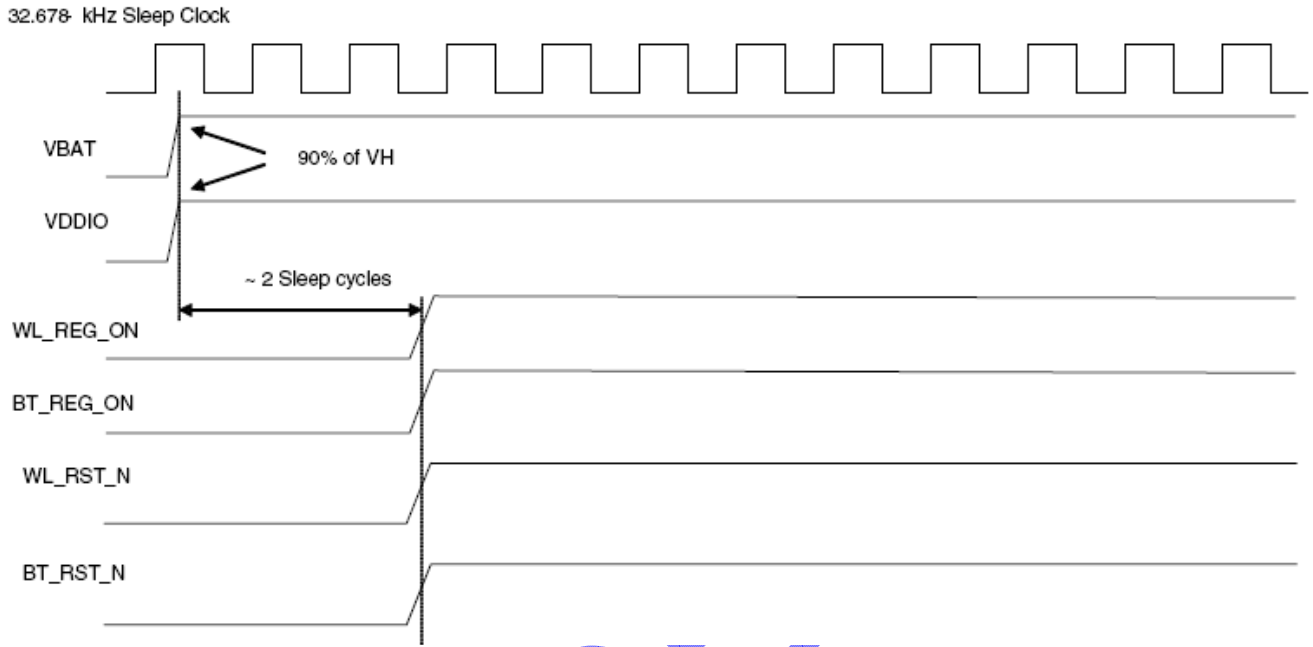

WLAN: ON, BT: ON

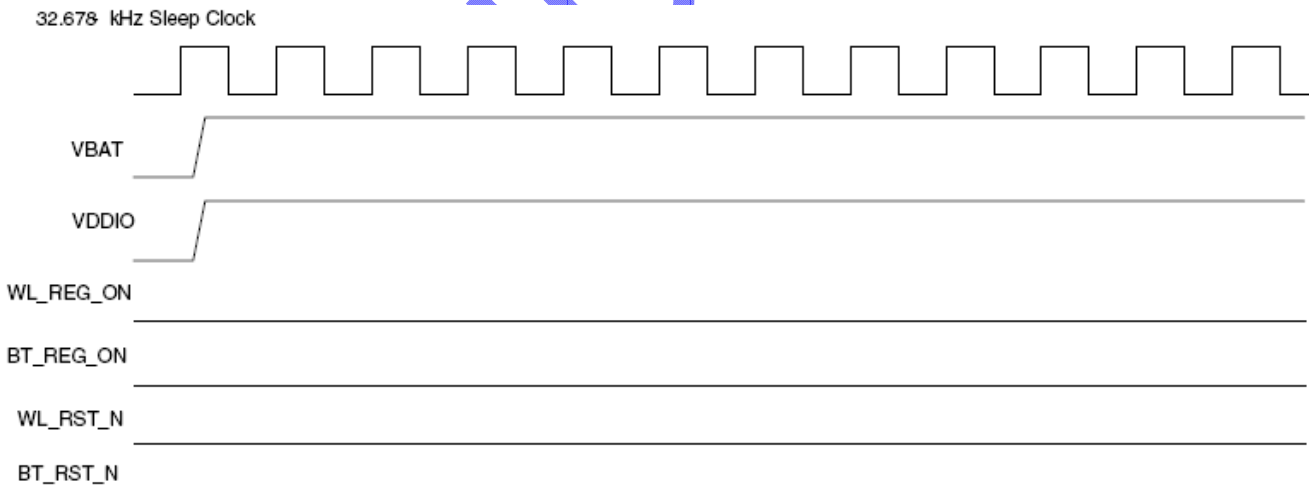

WLAN: OFF, BT: OFF

802.11b/g/n Wireless LAN + BT + FM 3 in One SiP Module V2.3

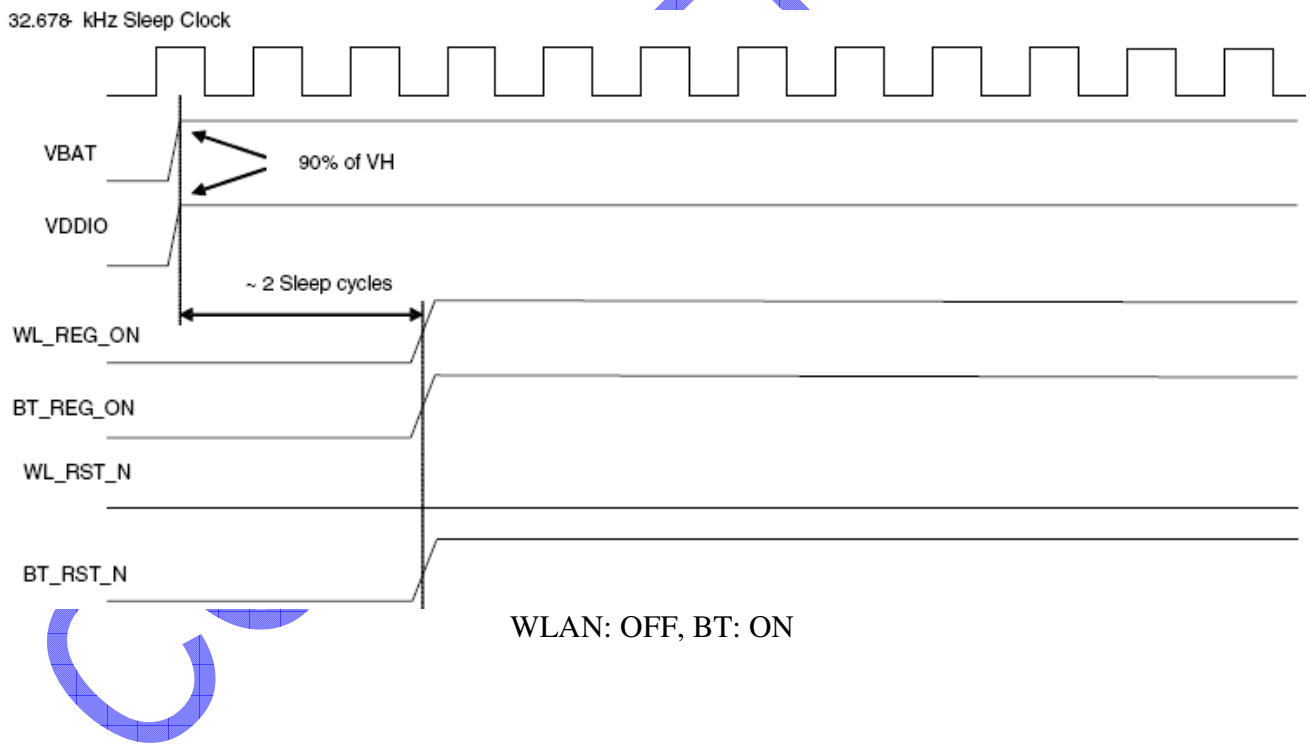
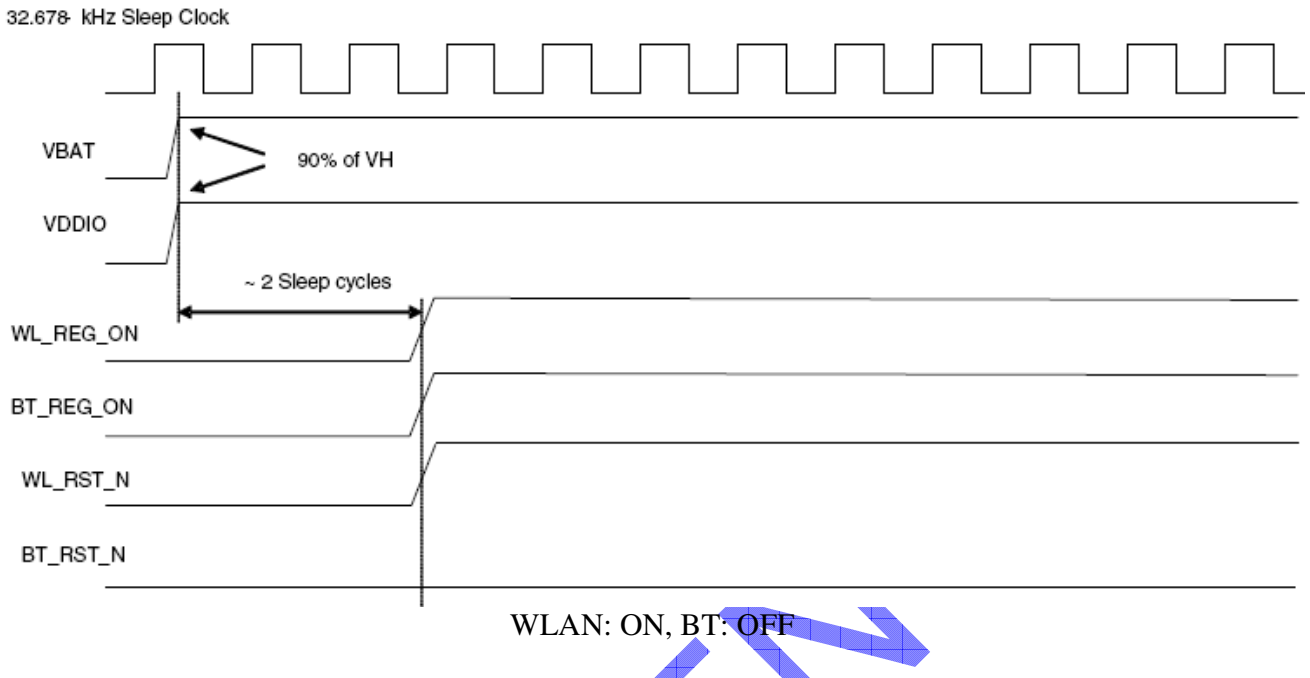

SDIO TIMING

SDIO timing in default mode

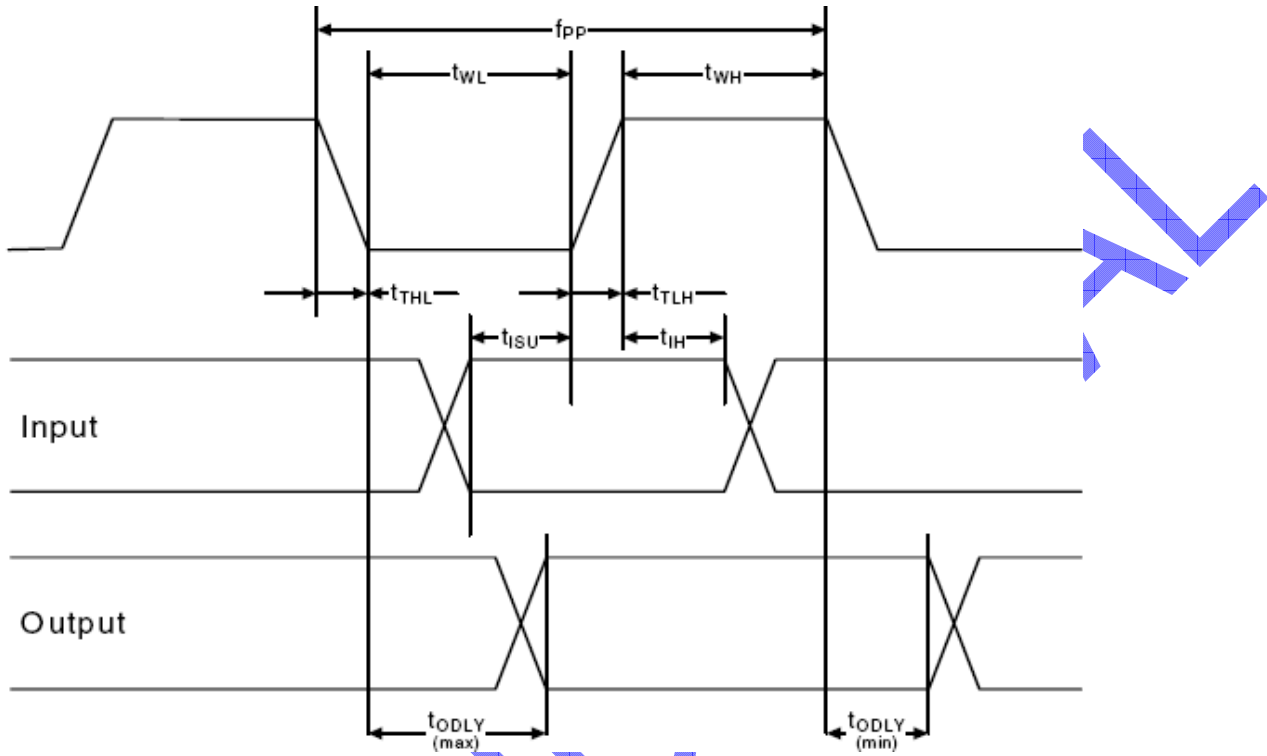

SDIO Bus Timing Parameters (Default Mode)

Parameter	Symbol	Min	Typical	Max	Unit
Clock CLK (All values are referred to min. VIH and max. VIL)					
Frequency--Data Transfer Mode	f_{PP}	0	-	25	MHz
Frequency--Identification Mode	f_{OD}	0	-	400	kHz
Clock Low Time	t_{WL}	10	-	-	ns
Clock High Time	t_{WH}	10	-	-	ns
Clock Rise time	t_{TLH}	-	-	10	ns
Clock Low Time	t_{THL}	-	-	10	ns
Inputs: CMD, DAT (referenced to CLK)					
Input Setup Time	t_{ISU}	5	-	-	ns
Input Hold Time	t_{IH}	5	-	-	ns
Outputs: CMD, DAT (referenced to CLK)					
Output Delay time--Data Transfer Mode	t_{ODLY}	0	-	14	ns
Output Delay time--Identification Mode	t_{ODLY}	0	-	50	ns

802.11b/g/n Wireless LAN + BT + FM 3 in One SiP Module V2.3

SDIO timing in High-Speed Mode

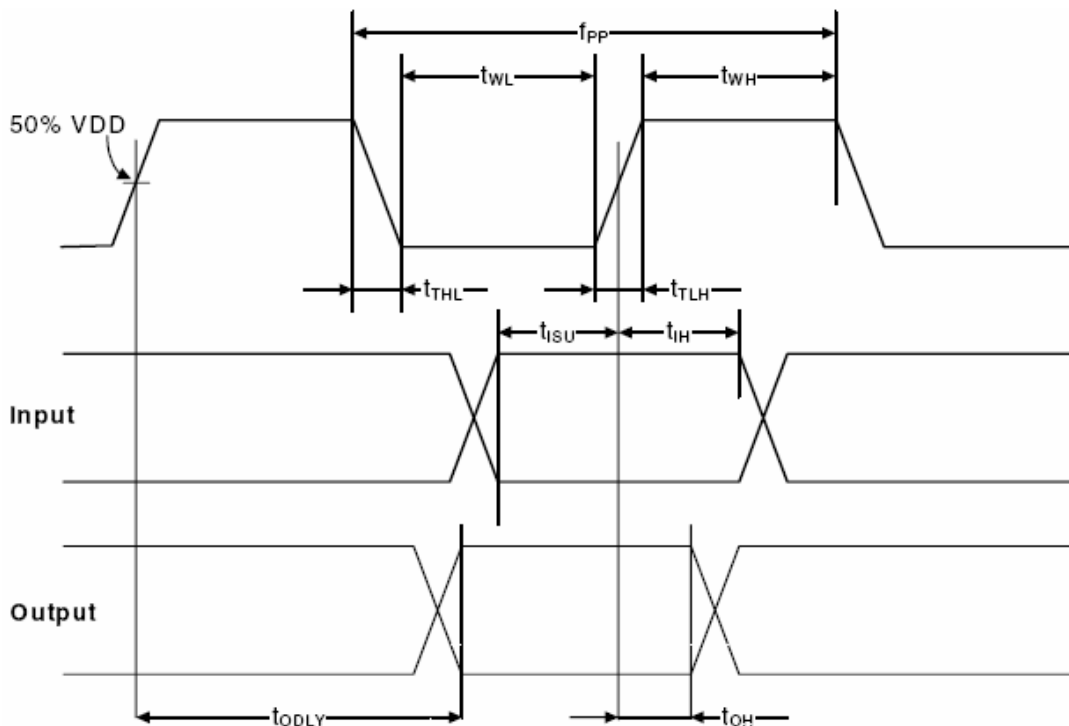

SDIO Bus Timing Parameters (High-Speed Mode)

Parameter	Symbol	Min	Typical	Max	Unit
Clock CLK (all values are referred to min. VIH and max. VIL)					
Frequency--Data Transfer Mode	f _{PP}	0	-	50	MHz
Frequency--Identification Mode	f _{OD}	0	-	400	kHz
Clock Low Time	t _{WL}	7	-	-	ns
Clock High Time	t _{WH}	7	-	-	ns
Clock Rise time	t _{TLH}	-	-	3	ns
Clock Low Time	t _{TLH}	-	-	3	ns
Inputs: CMD, DAT (referenced to CLK)					
Input Setup Time	t _{ISU}	6	-	-	ns
Input Hold Time	t _{IH}	2	-	-	ns
Outputs: CMD, DAT (referenced to CLK)					
Output Delay time--Data Transfer Mode	t _{ODLY}	-	-	14	ns
Output Hold time	t _{OH}	2.5	-	-	ns
Total System Capacitance (each line)	CL	-	-	40	pF

UART Timing

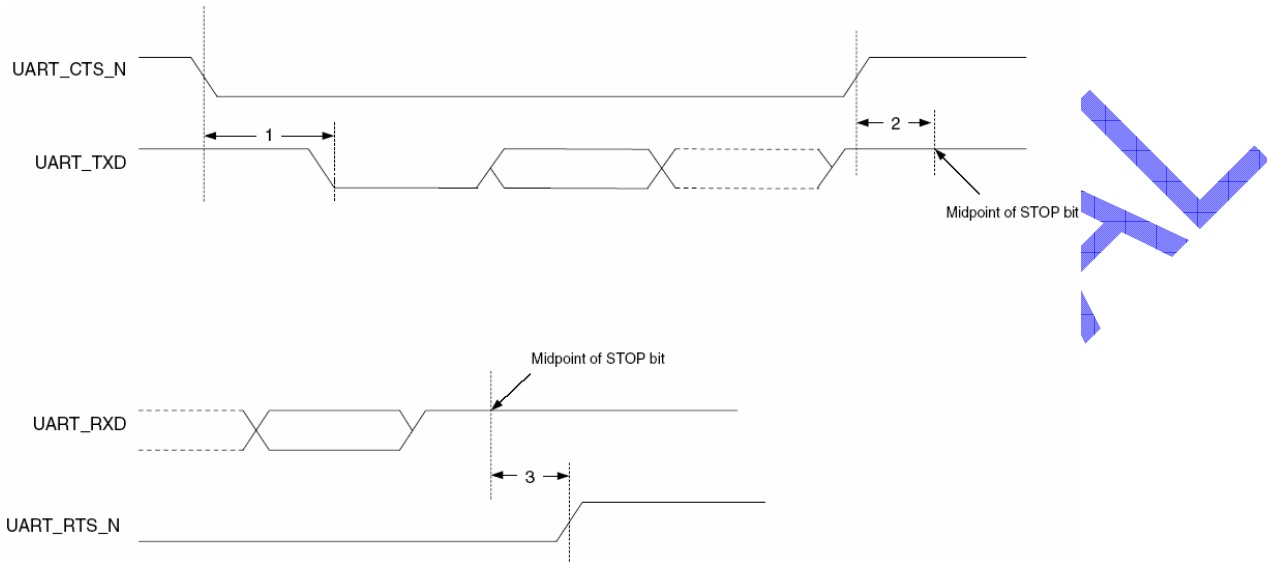

Reference	Description	Min	Typ	Max	Unit
1	Delay time, BT_UART_CTS_N low to UART_TXD valid	-	-	24	Baudout cycles
2	Setup time, BT_UART_CTS_N high before midpoint of stop bit	-	-	10	ns
3	Delay time, midpoint of stop bit to BT_UART_RTS_N high	-	-	2	Baudout cycles

PCM INTERFACE TIMING

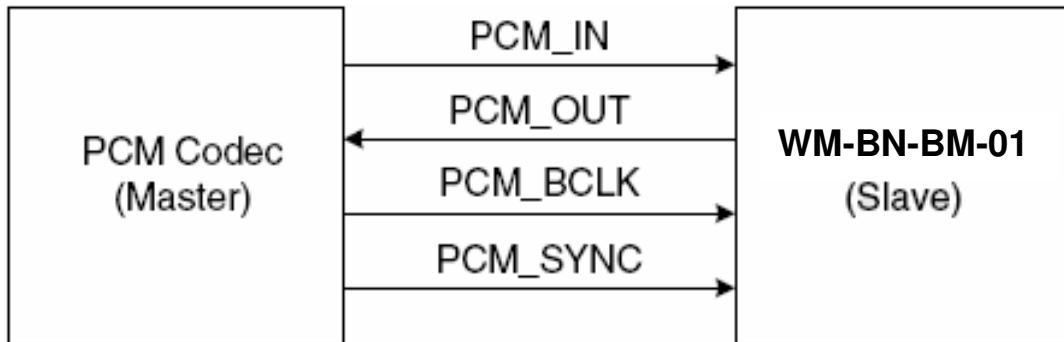

PCM Interface Slave Mode

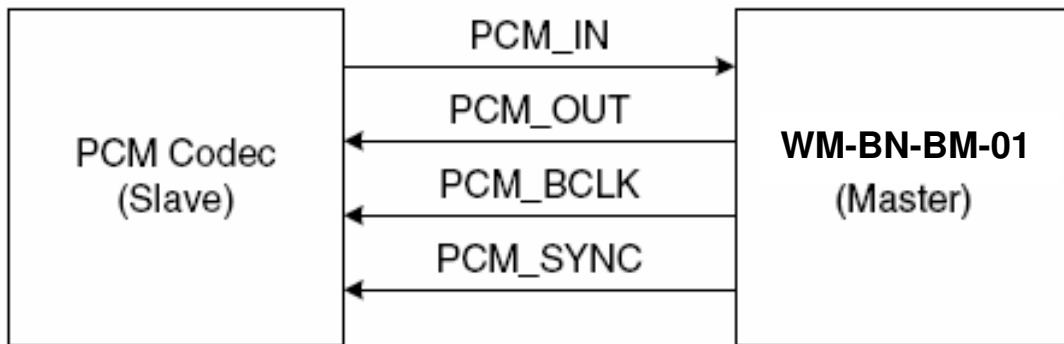

PCM Interface Master Mode

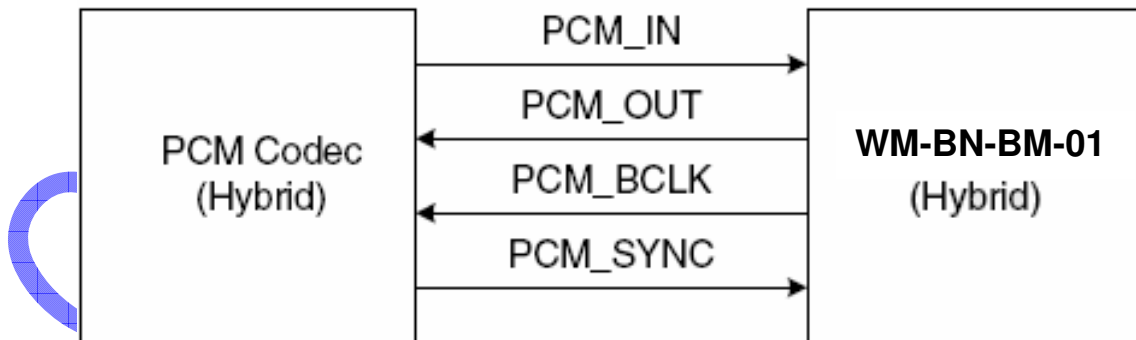

802.11b/g/n Wireless LAN + BT + FM 3 in One SiP Module V2.3

Short Frame Sync, Master Mode

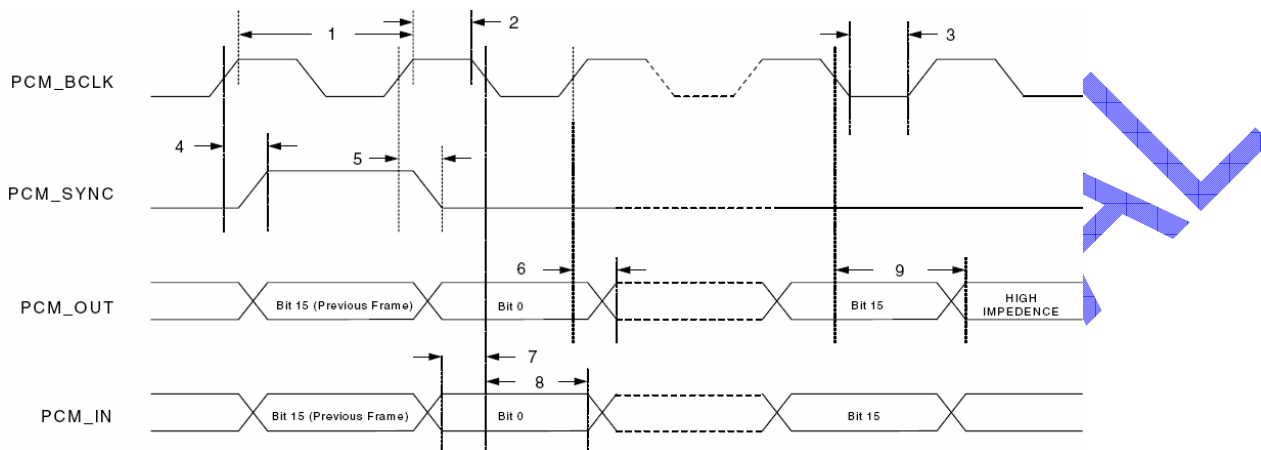

Reference	Description	Min	Typ	Max	Unit
1	PCM bit clock frequency	128	-	2048	kHz
2	PCM bit clock high time	128	-	-	ns
3	PCM bit clock low time	209	-	-	ns
4	Delay from BT_PCM_CLK rising edge to BT_PCM_SYNC high	-	-	50	ns
5	Delay from BT_PCM_CLK rising edge to BT_PCM_SYNC low	-	-	50	ns
6	Delay from BT_PCM_CLK rising edge to data valid on BT_PCM_OUT	-	-	50	ns
7	Setup time for BT_PCM_IN before BT_PCM_CLK falling edge	50	-	-	ns
8	Hold time for BT_PCM_IN after BT_PCM_CLK falling edge	10	-	-	ns
9	Delay from falling edge of BT_PCM_CLK during last bit period to BT_PCM_OUT becoming high impedance	-	-	50	ns

802.11b/g/n Wireless LAN + BT + FM 3 in One SiP Module V2.3

Short Frame Sync, Slave Mode

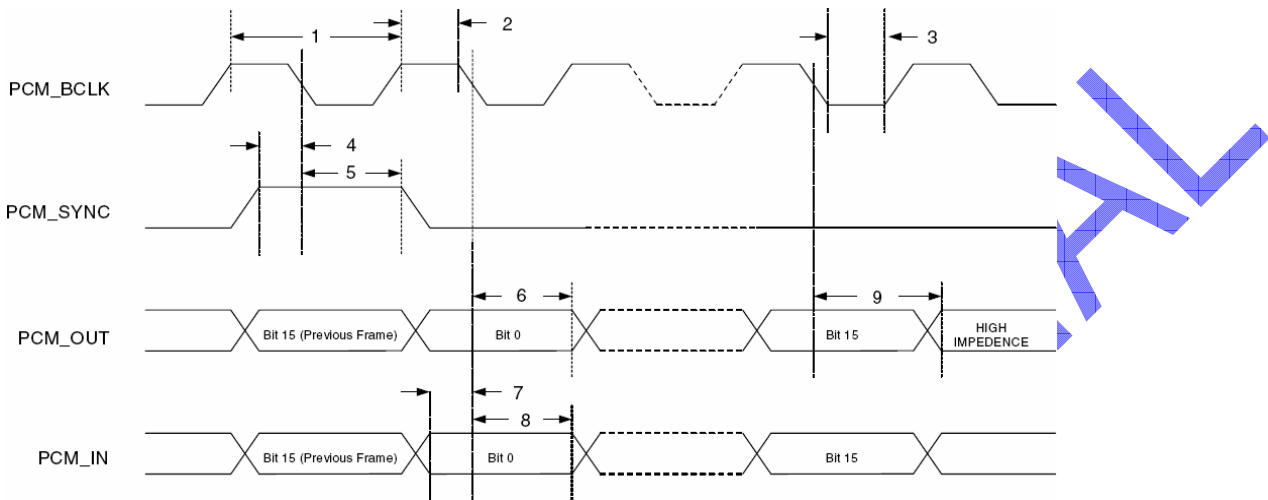

Reference	Description	Min	Typ	Max	Unit
1	PCM bit clock frequency	128	-	2048	kHz
2	PCM bit clock high time	209	-	-	ns
3	PCM bit clock low time	209	-	-	ns
4	Setup time for BT_PCM_SYNC before falling edge of BT_PCM_BCLK	50	-	-	ns
5	Hold time for BT_PCM_SYNC after falling edge of BT_PCM_CLK	10	-	-	ns
6	Hold time of BT_PCM_OUT after BT_PCM_CLK falling edge	-	-	175	ns
7	Setup time for BT_PCM_IN before BT_PCM_CLK falling edge	50	-	-	ns
8	Hold time for BT_PCM_IN after BT_PCM_CLK falling edge	10	-	-	ns
9	Delay from falling edge of BT_PCM_CLK during last bit period to BT_PCM_OUT becoming high impedance	-	-	100	ns

802.11b/g/n Wireless LAN + BT + FM 3 in One SiP Module V2.3

Long Frame Sync, Master Mode

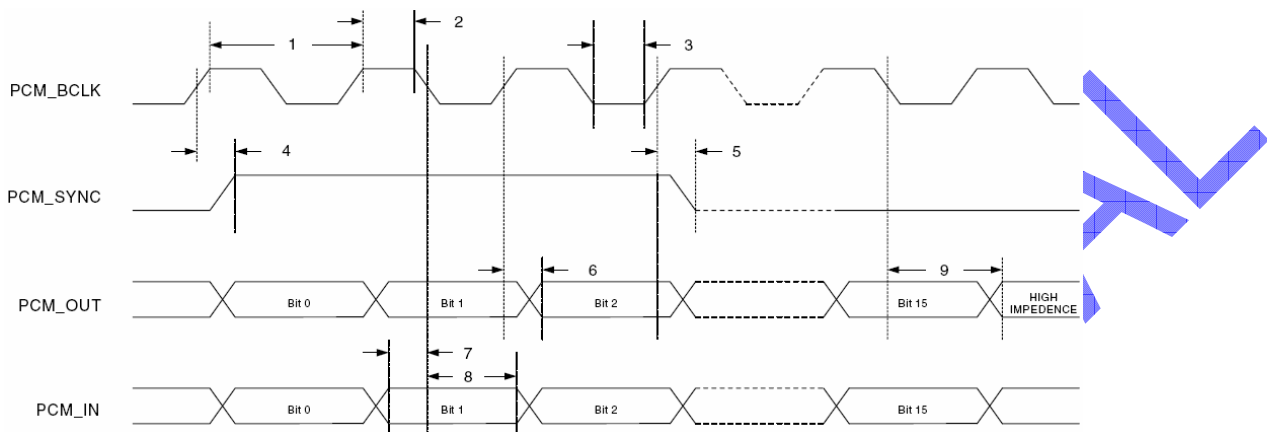

Reference	Description	Min	Typ	Max	Unit
1	PCM bit clock frequency	128	-	2048	kHz
2	PCM bit clock high time	209	-	-	ns
3	PCM bit clock low time	209	-	-	ns
4	Delay from BT_PCM_CLK rising edge to BT_PCM_SYNC high	-	-	50	ns
5	Delay from BT_PCM_CLK rising edge to BT_PCM_SYNC low	-	-	50	ns
6	Delay from BT_PCM_CLK rising edge to data valid on BT_PCM_OUT	-	-	50	ns
7	Setup time for BT_PCM_IN before BT_PCM_CLK falling edge	50	-	-	ns
8	Hold time for BT_PCM_IN after BT_PCM_CLK falling edge	10	-	-	ns
9	Delay from falling edge of BT_PCM_CLK during last bit period to BT_PCM_OUT becoming high impedance	-	-	50	ns

802.11b/g/n Wireless LAN + BT + FM 3 in One SiP Module V2.3

Long Frame Sync, Slave Mode

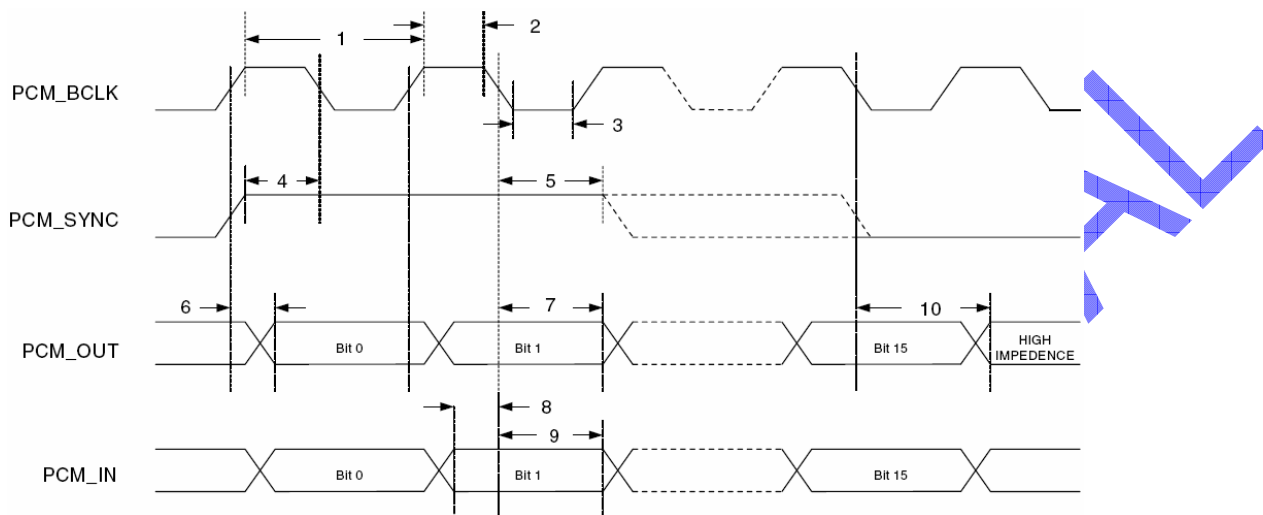

Reference	Description	Min	Typ	Max	Unit
1	PCM bit clock frequency	128	–	2048	kHz
2	PCM bit clock high time	209	–	–	ns
3	PCM bit clock low time	209	–	–	ns
4	Setup time for BT_PCM_SYNC before falling edge of BT_PCM_CLK during first bit	50	–	–	ns
5	Hold time for BT_PCM_SYNC after falling edge of BT_PCM_CLK during second bit period. (BT_PCM_SYNC may go low any time from second bit period to last bit period)	10	–	–	ns
6	Delay from rising edge of BT_PCM_CLK or BT_PCM_SYNC (whichever is later) to data valid for first bit on BT_PCM_OUT	–	–	50	ns
7	Hold time of BT_PCM_OUT after BT_PCM_CLK falling edge	–	–	175	ns
8	Setup time for BT_PCM_IN before BT_PCM_CLK falling edge	50	–	–	ns
9	Hold time for BT_PCM_IN after BT_PCM_CLK falling edge	10	–	–	ns
10	Delay from falling edge of BT_PCM_CLK or BT_PCM_SYNC (whichever is later) during last bit in slot to BT_PCM_OUT becoming high impedance	–	–	100	ns

802.11b/g/n Wireless LAN + BT + FM 3 in One SiP Module V2.3

Module Interface during Sleep mode

WM-BN-BM-01 During Sleep					
Reset/Control	I/O Type	I/O	Pull R	I/O	Pull R
BT_RST_N	Digital	Input	None		
WL_RST_N (WLAN_ENABLE)	Digital	Input	PD		
BT_GPIO_0 (BT_WAKE)	Digital	Input	None		
BT_GPIO_1 (UART_WAKEUP) Digital	None	Output (low)	None		
UART					
BT_UART_RXD	Digital	Input	None		
BT_UART_TXD	Digital	Output (high)	None		
BT_UART_CTS_N	Digital	Input	None		
BT_UART_RTS_N	Digital	Output (high)	None		
SPI (WLAN)					
SPI_SDI	Digital	Input	None		
SPI_SDO	Digital	Output	None		
SPI_CLK	Digital	Input	None		
SPI_CS	Digital	Input	None		
SPI_IRQ	Digital	Output	None		
SDIO (WLAN)					
SDIO_CLK	Digital	Input	None		
SDIO_CMD	Digital	Bidirectional	PU		
SDIO_DATA0	Digital	Bidirectional	PU		
SDIO_DATA1	Digital	Bidirectional	PU		
SDIO_DATA2	Digital	Bidirectional	PU		
SDIO_DATA3	Digital	Bidirectional	PU		
Clock					
XTAL_PU (CLK_REQ)	Digital	-	-		
WRF_EXTREFIN (32.768 kHz LPO Clock)	CLK	Input	None		
OSCIN (Ref Clock)	CLK	Input	None		
4-Wire (PCM)		Master Mode		Slave Mode	
BT_PCM_IN	Digital	Input	None	Input	None
BT_PCM_OUT	Digital	High Z	None	High Z	None
BT_PCM_CLK	Digital	Output (low)	None	Input	None
BT_PCM_SYNC	Digital	Output (low)	None	Input	None

PD: Pull Down, PU: Pull UP

802.11b/g/n Wireless LAN + BT + FM 3 in One SiP Module V2.3

5.9. DIMENSIONS, WEIGHT AND MOUNTING

The following paragraphs provide the requirements for the size, weight and mounting of the WM-BN-BM-01 module.

5.9.1. DIMENSIONS

The size and thickness of the WM-BN-BM-01 module is 10 mm (W) x 10 mm (L) x 1.3 mm (H) (Including Metal Shielding)

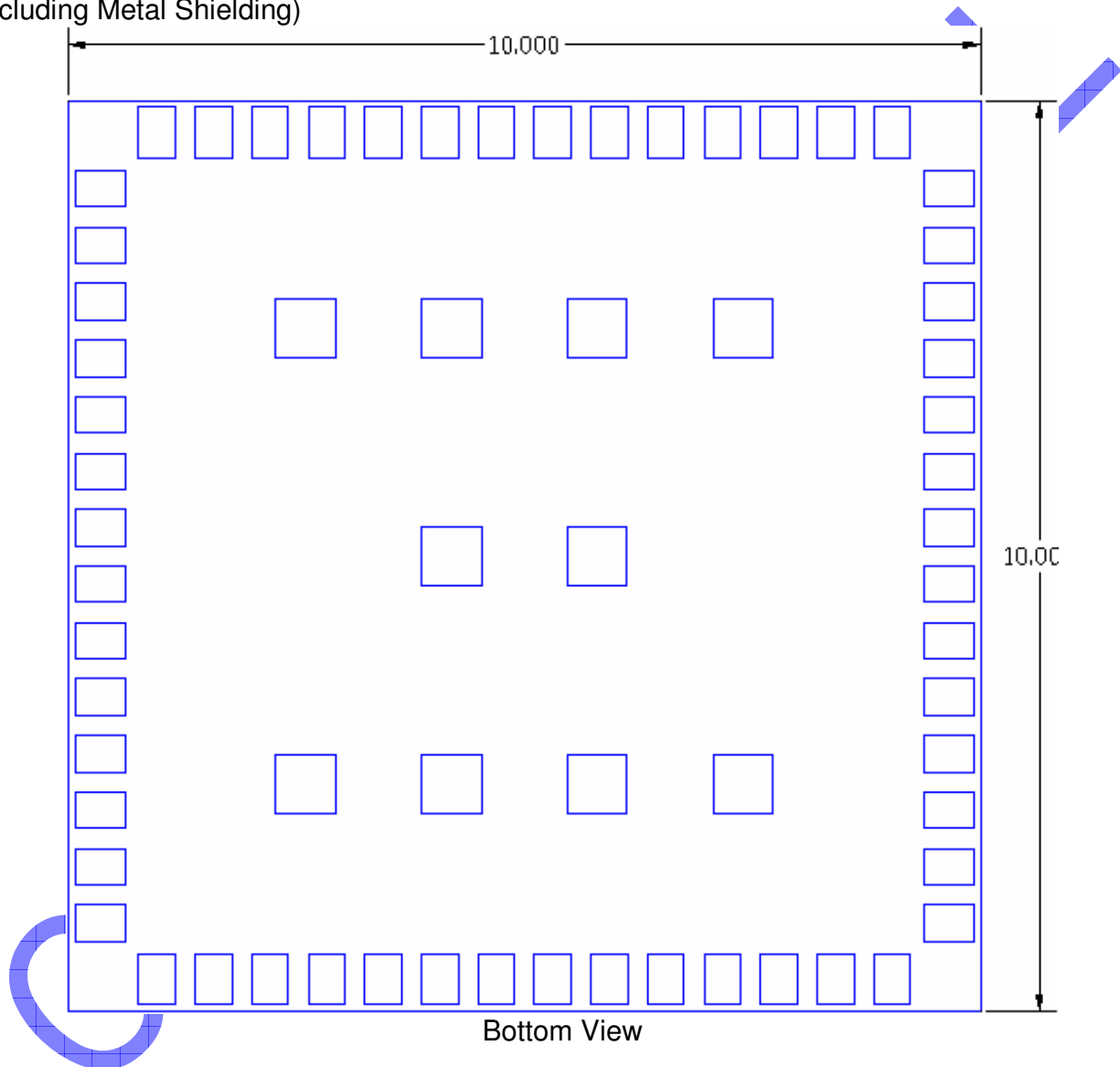

6. LEGAL, REGULATORY & OTHER TECHNICAL CONSTRAINTS

The WM-BN-BM-01 module is pre-tested to ensure that all requirements met as set forth in the following sections.

Final certification (module certification) requires the antenna of targeted system with a lead-time of 6 weeks. The product deliverable shall be a pre-tested WM-BN-BM-01 module. No module level certification on WM-BN-BM-01 module.

802.11b/g/n Wireless LAN + BT + FM 3 in One SiP Module V2.3

7. PIN OUT AND PIN DESCRIPTION

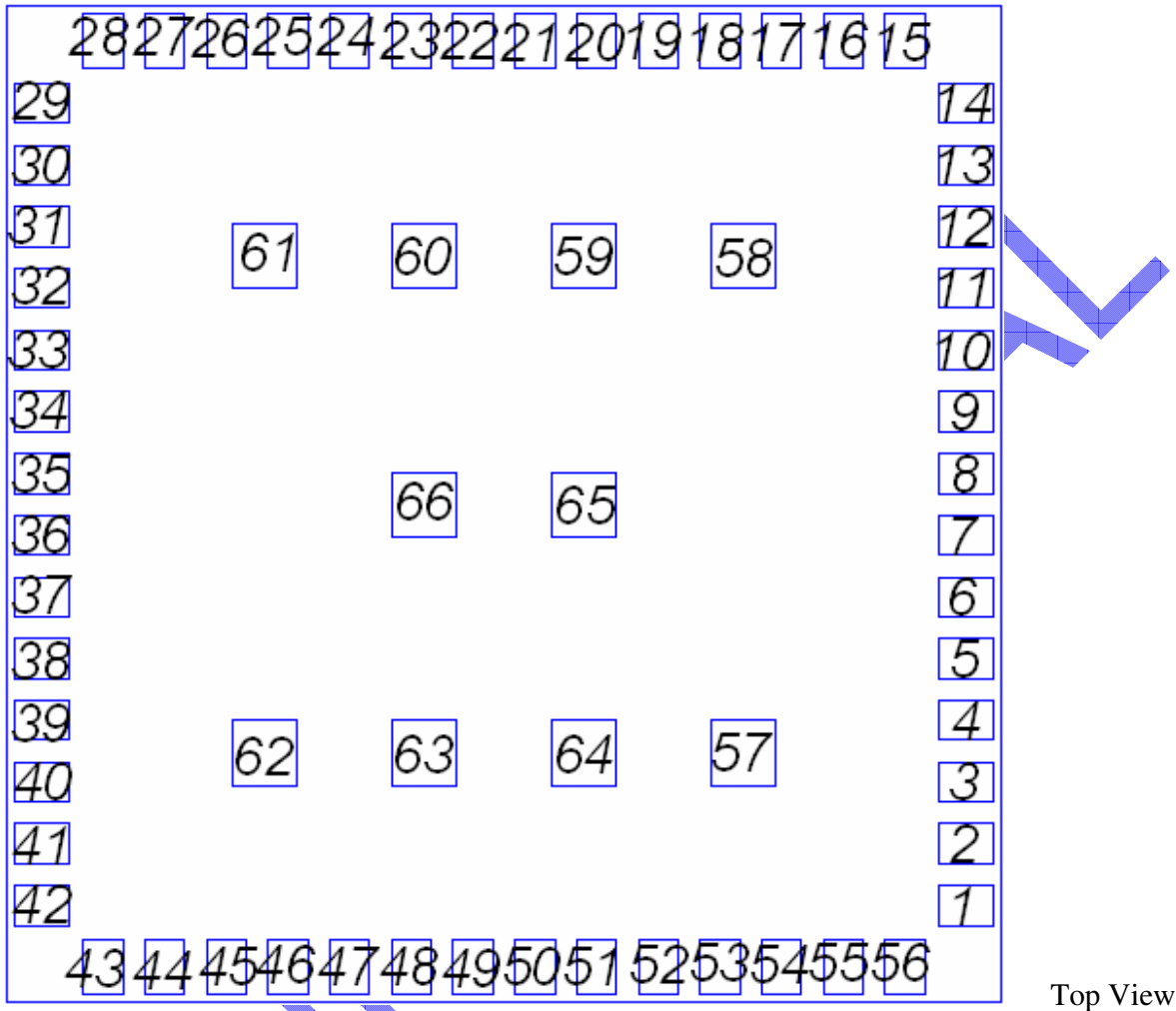

Pin Description

Pin-Number	Pin-Define	Type	Description
1	GND	I	Ground
2	GND	I	Ground
3	SW_RX2	O	Control signal for Antenna Diversity RF2
4	SW_RX1	O	Control signal for Antenna Diversity RF1
5	TDO	I	For debug only
6	TAG_TRST_N	I	For debug only
7	WL_RST_N	I	Low asserting reset for WLAN core
8	TCK	I	For debug only
9	TMS	I	For debug only

All rights are reserved by USI. No part of this technical document can be reproduced in any form without permission of USI

802.11b/g/n Wireless LAN + BT + FM 3 in One SiP Module V2.3

10	WL_GPIO_1	O	<p>HOST_WAKE</p> <p>Host wake up: Signal from the module to the host indicating that the module requires attention.</p> <ul style="list-style-type: none"> • Asserted: Host device must wake-up or remain awake. • Deasserted: Host device may sleep when sleep criteria are met. <p>The polarity of this signal is software configurable and can be asserted high or low.</p>
11	WL_GPIO_0	I	<p>WLAN_WAKE</p> <p>WLAN device wake-up: Signal from the host to the module indicating that the host requires attention.</p> <ul style="list-style-type: none"> • Asserted: WLAN device must wake-up or remain awake. • Deasserted: WLAN device may sleep when sleep criteria are met. <p>The polarity of this signal is software configurable and can be asserted high or low.</p>
12	TDI	I	For debug only
13	VDDIO	I	Digital I/O supply (1.8V~ 3.3V)
14	XTAL_PU	O	Crystal circuit/reference clock enable (programmable polarity, default is active high)
15	SDIO_CLK	I/O	SDIO clock. This pin has an internal weak pull-up resistor.
16	VDDIO_SD	I	Digital I/O supply (1.8V~ 3.3V)
17	SDIO_D0	I/O	SDIO data 0. This pin has an internal weak pull-up resistor.
18	SDIO_D2	I/O	SDIO data 2. This pin has an internal weak pull-up resistor.
19	SDIO_CMD	I/O	SDIO command. This pin has an internal weak pull-up resistor.
20	SDIO_D3	I/O	SDIO data 3. This pin has an internal weak pull-up resistor.
21	SDIO_D1	I/O	SDIO data 1. This pin has an internal weak pull-up resistor.
22	BT_GPIO0	I	<p>BT_WAKE</p> <p>Bluetooth device wake-up: Signal from the host to the module indicating that the host requires attention.</p> <ul style="list-style-type: none"> • Asserted: Bluetooth device must wake-up or remain awake. • Deasserted: Bluetooth device may sleep when sleep criteria are met. <p>The polarity of this signal is software configurable and can be asserted high or low.</p>
23	BT_GPIO1	O	HOST_WAKE

802.11b/g/n Wireless LAN + BT + FM 3 in One SiP Module V2.3

			<p>Host wake up. Signal from the module to the host indicating that the module requires attention.</p> <ul style="list-style-type: none"> • Asserted: Host device must wake-up or remain awake. • Deasserted: Host device may sleep when sleep criteria are met. <p>The polarity of this signal is software configurable and can be asserted high or low.</p>
24	BT_PCM_SYNC	I/O	PCM sync signal, can be master (output) or slave (input)
25	BT_PCM_CLK	I/O	PCM clock, can be master (output) or slave (input)
26	GND	I	Ground
27	VBAT	I	Battery supply input (2.8V~5V)
28	VBAT	I	Battery supply input (2.8V~5V)
29	VIN_IP2LDO-L	O	Connect to Boost L (3.3uH is required)
30	VIN_IP2LDO	I	Connect to Boost L (3.3uH is required)
31	WL_BT_REG_ON	I	Used by PMU (along with WL_REG_ON) to decide whether or not to power down internal BCM4329 regulators. If both BT_REG_ON and WL_REG_ON are low then the regulators will be disabled.
32	BT_UART_RXD	I/O	Bluetooth UART Serial Input. Serial data input for the HCI UART Interface.
33	BT_UART_TXD	I/O	Bluetooth UART Serial Output. Serial data output for the HCI UART Interface.
34	GND	I	Ground
35	GND	I	Ground
36	WRF_EXTREFIN	I	32.768kHz external reference clock input
37	GND	I	Ground
38	FM_AUDIO_OUT1	O	FM analog audio output channel 1
39	FM_AUDIO_OUT_R	O	FM analog audio output channel 2
40	GND	I	Ground
41	GND	I	Ground
42	GND	I	Ground
43	FM_RXP	I	FM radio RF antenna Port
44	FM_RXN	I	FM radio RF antenna Port
45	GND	I	Ground
46	GND	I	Ground

802.11b/g/n Wireless LAN + BT + FM 3 in One SiP Module V2.3

47	GND	I	Ground
48	GND	I	Ground
49	BT_UART_RTS_N	I/O	Bluetooth UART Request to Send. Active-low request-to-send signal for the HCI UART interface.
50	BT_PCM_IN	I/O	PCM data input
51	BT_UART_CTS_N	I/O	Bluetooth UART Clear to Send. Active-low clear-to-send signal for the HCI UART interface.
52	BT_PCM_OUT	I/O	PCM data output
53	BT_RST_N	I	Low asserting reset for BT core
54	GND	I	Ground
55	GND	I	Ground
56	ANT	I/O	Antenna port for WLAN and Bluetooth
57~66	GND	I	Ground

CONFIDENTIAL

802.11b/g/n Wireless LAN + BT + FM 3 in One SiP Module V2.3

8. RECOMMEND FOOTPRINT

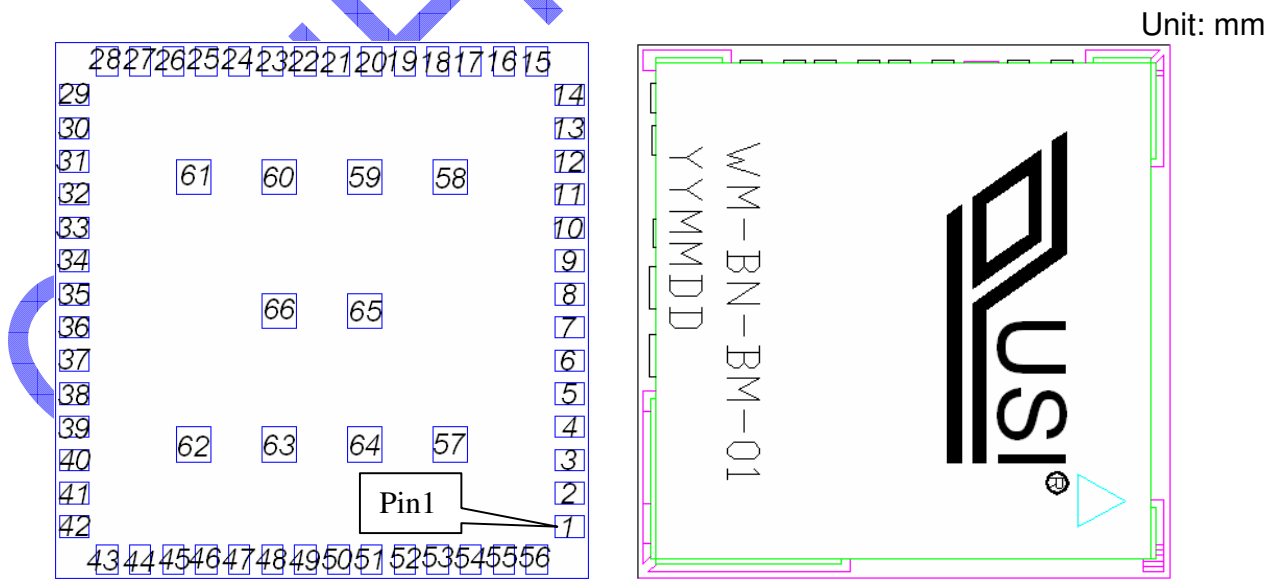
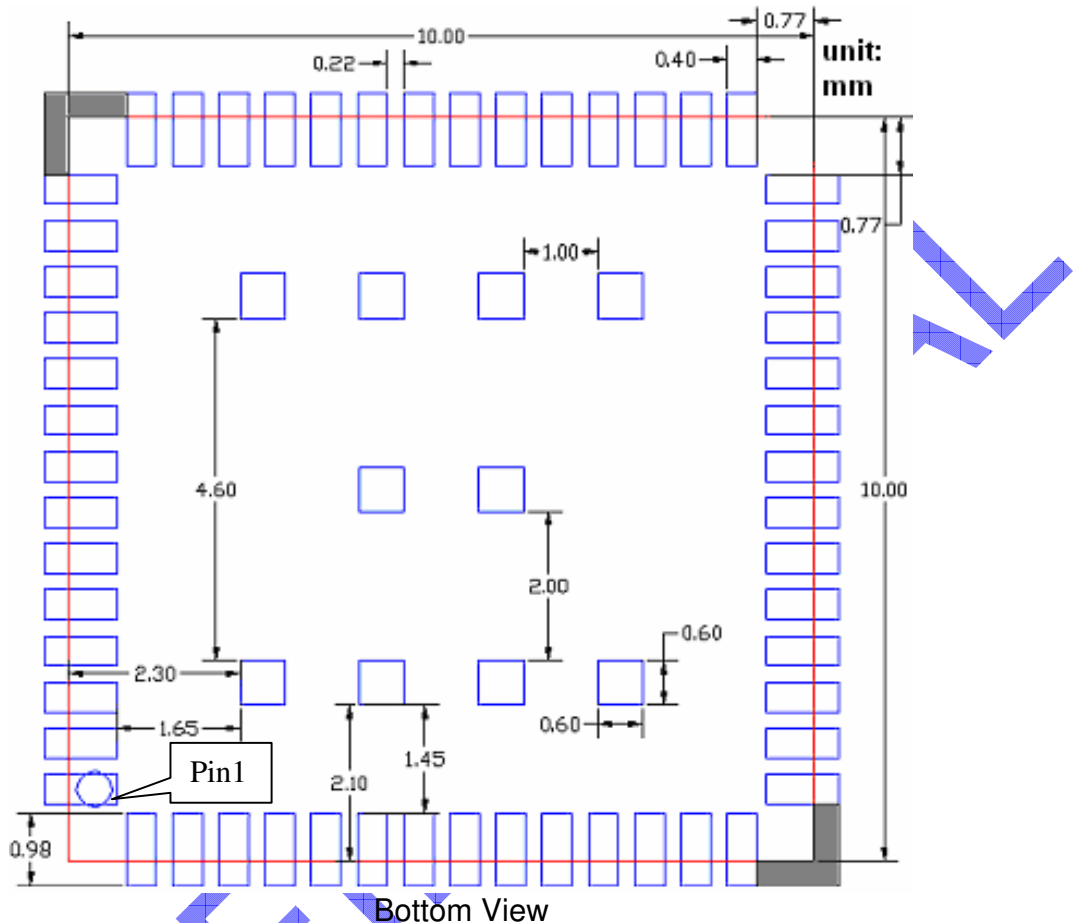

TOP View

9. RECOMMENDED REFLOW PROFILE

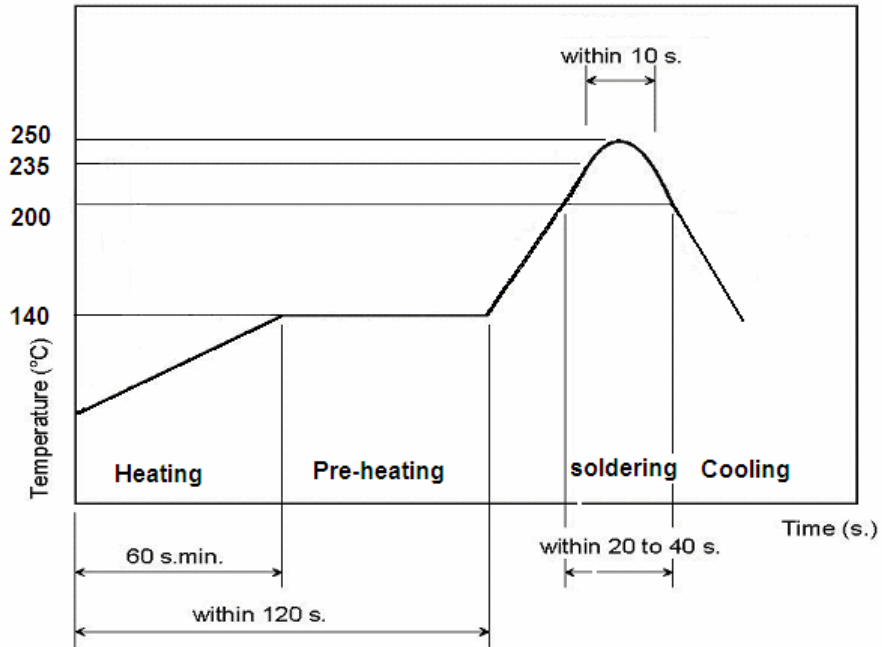

CONFIDENTIAL



10. PACKAGE AND STORAGE CONDITION

10.1 Package Dimension

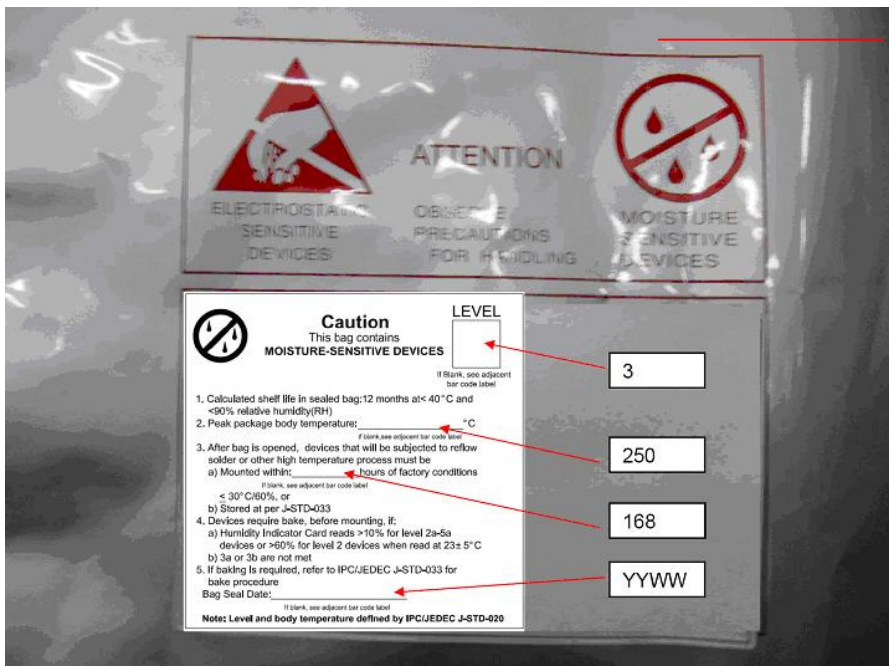

10.2 ESD Level

Note:

1. Surface Resistivity:
Interior: $10^9 \sim 10^{11} \Omega/\text{SQUARE}$
EXTERIOR: $10^8 \sim 10^{12} \Omega/\text{SQUARE}$
2. Dimension: 475*420mm
3. Tolerance: +5,0mm
4. Color:
Background : Gray
Text : Red

802.11b/g/n Wireless LAN + BT + FM 3 in One SiP Module V2.3

10.3 Tap/Reel Dimension

Embossed carrier tape	Top cover tape	Each Item Size						
		W \pm 0.15m/m	W \pm 0.15m/m	A	B \pm 0.5	D \pm 1.0	C \pm 0.2	N \pm 1.0
8	5.3/5.5	330	2.2	20.2	13	100	8.5	13.1
12	9.3	330	2.2	20.2	13	100	12.5	17.1
16	13.3	330	2.2	20.2	13	100	16.5	21.1
24	21.3	330	2.2	20.2	13	100	24.5	29.1
32	25.5	330	2.2	20.2	13	100	32.5	37.1
44	37.5	330	2.2	20.2	13	100	44.5	49.1
56	49.5	330	2.2	20.2	13	100	56.5	61.1



USI P/N:59-730113-02

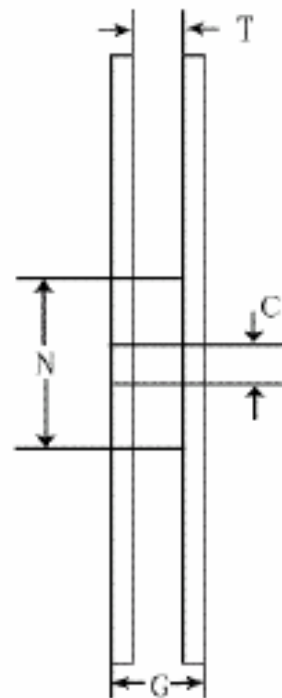
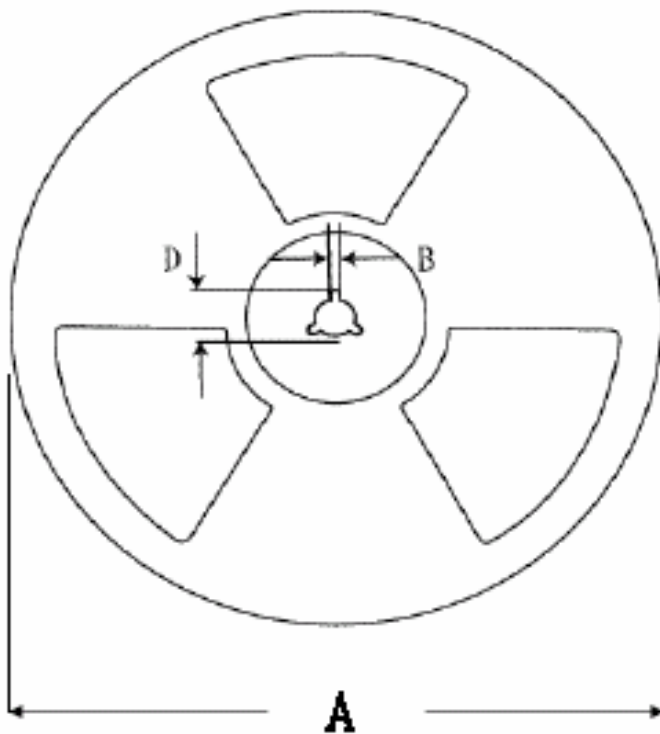

802.11b/g/n Wireless LAN + BT + FM 3 in One SiP Module V2.3

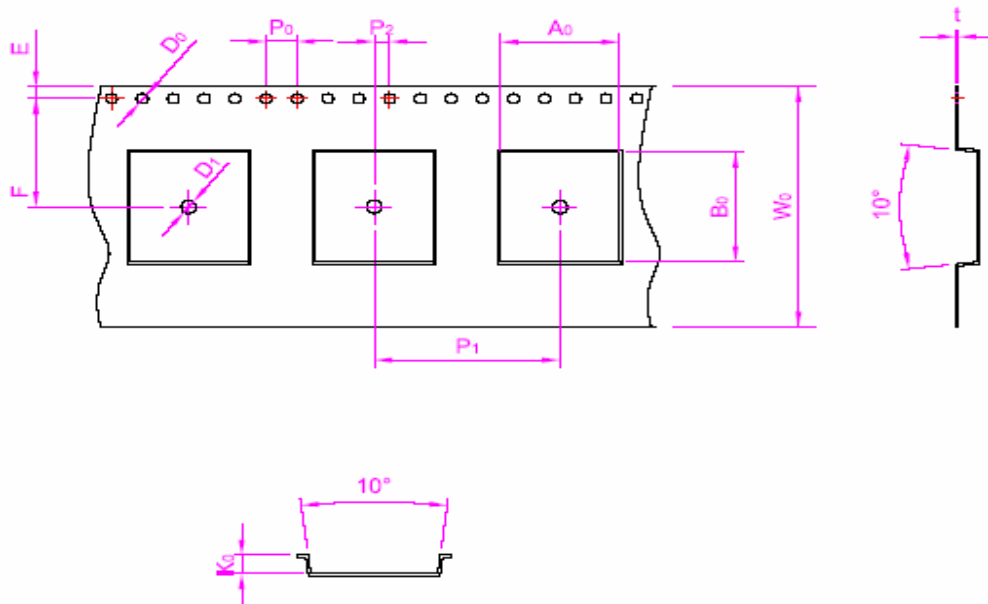

ITEM	A_0	B_0	D_0	D_1	E	F	K_0
SPEC	9.9 ± 0.1	9.9 ± 0.1	$1.50 \pm 0.1 / -0$	$1.5 \pm 0.1 / -0$	1.75 ± 0.1	11.5 ± 0.1	1.95 ± 0.1
ITEM	K_1	P_0	P_1	P_2	$P_0 \times 10$	t	W_0
SPEC		4.00 ± 0.1	12.0 ± 0.1	2.00 ± 0.1	Cumulative Tolerance ± 0.2	0.40 ± 0.05	24 ± 0.3

Length leader / trailer tape:

Leader tape: ≥ 550 mm which includes ≥ 100 mm of carrier tape with empty compartments and covered with tape; remaining part might be of cover tape only.

Trailer tape: ≥ 160 mm with empty compartments and covered with tape.

NOTES:

1. Material: Conductive Polystyrene (Recycle)

2. Color: Black

3. Surface resistance: 10^6 Ohms/square 以下

3. Cumulative tolerance per 10 pitches (P_0) is ± 0.2 mm.

4. Carrier camber shall be not more than 1mm per 100mm, noncumulative over 250mm

5. A_0 & B_0 are measured on the plane by 0.3 mm above the bottom of the pocket.

6. K_0 is measured from the inside bottom of the pocket to the top surface of the carrier.

7. Pocket position relative to sprocket hold is measured as true position of pocket, not sprocket hold.

802.11b/g/n Wireless LAN + BT + FM 3 in One SiP Module V2.3

10.4 MSL Level / Storage Condition



CAUTION
This bag contains
MOISTURE-SENSITIVE DEVICES

LEVEL

3

If Blank, see adjacent bar code label

1. Calculated Shelf life in sealed bag: 12 months at < 40°C and < 90%Relative humidity (RH)

2. Peak package body temperature 250 °C
If Blank, see adjacent bar code label

3. After bag is opened, Devices that will be subjected to reflow solder or other high temperature process must

(a) Mounted within: 168 hrs. Of factory conditions ≤ 30°C/60% RH, OR
If Blank, see adjacent bar code label

(b) Stored at < 10°C RH.

4. Devices require bake, before mounting, it:

(a) Humidity indicator Card is >10% when read at 23±5°C

(b) 3a or 3b not met.

5. If baking is required, Devices may be baked for 24 hrs at 125±5°C
Note: If device containers cannot be subjected to high temperature
Or shorter bake times are desired. Reference IPC/JEDEC J-STD-033 for bake procedure
Bag Seal Date: _____ Note: Level and body temperature defined by IPC/JEDEC J-STD-020
If Blank, see adjacent bar code label

Half-Sine Shock
Sustained for Mechanical Shock under 2000G
Life cycle: 2.5 years

Broadcom is Trademark of 3rd Party.

For Additional information, please contact the following:

Universal Scientific Industrial Co., Ltd.

Headquarters

141, Lane 351, Taiping Road, Sec. 1, Tsao-Tuen, Taiwan,

[Http://www.usi.com.tw](http://www.usi.com.tw)

Tel: + 886-49-2350876, 2325876

Fax: +886-49-3439561, 2337360,2351093

E-mail: usi@ms.usi.com.tw
