

Bottom Port Analog Silicon Microphone

DESCRIPTION

The WM7132P is a low-profile silicon analog microphone. It offers high Signal to Noise Ratio (SNR) and low power consumption and is suited to a wide variety of consumer applications.

The WM7132P incorporates Cirrus proprietary CMOS/MEMS membrane technology, offering high reliability and high performance in a miniature, low-profile package. The WM7132P is designed to withstand the high temperatures associated with automated flow solder assembly processes. (Note that conventional microphones can be damaged by this process.)

The WM7132P Bottom Port microphone offers matched performance to the WM7121P Top Port microphone. The matched characteristics enable highly accurate sound pick-up in opposite directions, suitable for noise cancellation and other DSP algorithms.

The WM7132P offers a tight tolerance on the microphone sensitivity, giving reduced variation between parts. This removes the need for in-line production calibration of part-to-part microphone variations.

FEATURES

- High SNR (65dB)
- Low variation in sensitivity (± 1 dB tolerance)
- Matched pair with Top Port microphone WM7121P
 - Matched sensitivity, roll-off, and phase response
- Low current consumption (190 μ A)
- Analog output
- Bottom Port LGA Package
- 1.5V to 3.7V supply

APPLICATIONS

- Mobile phone handsets
- Portable media players
- Digital still cameras
- Digital video cameras
- Bluetooth headsets
- Portable navigation devices
- Portable games consoles

BLOCK DIAGRAM

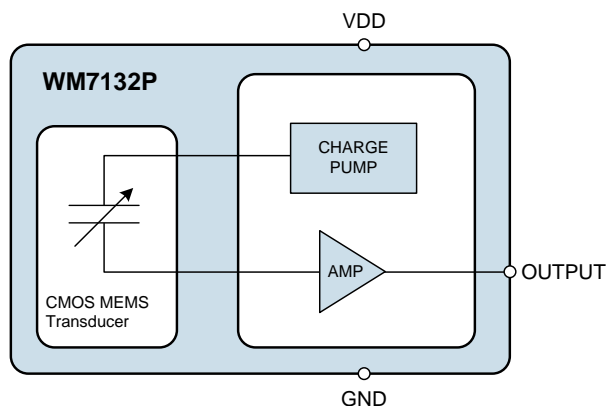

3D VIEW

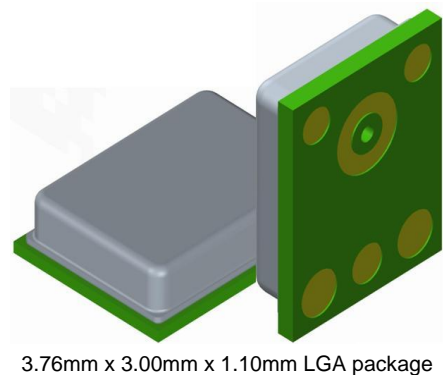
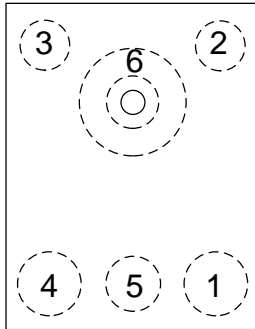

TABLE OF CONTENTS

DESCRIPTION	1
FEATURES	1
APPLICATIONS	1
BLOCK DIAGRAM	1
3D VIEW	1
TABLE OF CONTENTS	2
PIN CONFIGURATION	3
PIN DESCRIPTION	3
ORDERING INFORMATION	3
ABSOLUTE MAXIMUM RATINGS	4
IMPORTANT ASSEMBLY GUIDELINES	4
RECOMMENDED OPERATING CONDITIONS	4
ACOUSTIC AND ELECTRICAL CHARACTERISTICS	5
TERMINOLOGY	5
TYPICAL PERFORMANCE	6
APPLICATIONS INFORMATION	7
RECOMMENDED EXTERNAL COMPONENTS	7
OPTIMISED SYSTEM RF DESIGN	7
CONNECTION TO A CIRRUS AUDIO CODEC	8
MATCHED MICROPHONE PAIRS	8
PCB LAND PATTERN AND PASTE STENCIL	9
PACKAGE DIMENSIONS	10
IMPORTANT NOTICE	11
REVISION HISTORY	12

PIN CONFIGURATION

Top View

PIN DESCRIPTION

PIN	NAME	TYPE	DESCRIPTION
1	OUTPUT	Analog Output	Microphone analog output signal
2	GND	Supply	Analog ground
3	GND	Supply	Analog ground
4	VDD	Supply	Analog supply
5	GND	Supply	Analog ground
6	GND	Supply	Analog ground

ORDERING INFORMATION

ORDER CODE	TEMPERATURE RANGE	PACKAGE	MOISTURE SENSITIVITY LEVEL	PEAK SOLDERING TEMPERATURE
WM7132PIMSE/RV	-40 to +100°C	LGA (tape and reel)	MSL2A	+260°C

Note:

Reel quantity = 5000

All devices are Pb-free and Halogen free.

ABSOLUTE MAXIMUM RATINGS

Absolute Maximum Ratings are stress ratings only. Permanent damage to the device may be caused by continuously operating at or beyond these limits. Device functional operating limits and guaranteed performance specifications are given under Electrical Characteristics at the test conditions specified.



ESD Sensitive Device. This device is manufactured on a CMOS process. It is therefore generically susceptible to damage from excessive static voltages. Proper ESD precautions must be taken during handling and storage of this device.

Cirrus tests its package types according to IPC/JEDEC J-STD-020 for Moisture Sensitivity to determine acceptable storage conditions prior to surface mount assembly. These levels are:

MSL1 = unlimited floor life at <30°C / 85% Relative Humidity. Not normally stored in moisture barrier bag.

MSL2 = out of bag storage for 1 year at <30°C / 60% Relative Humidity. Supplied in moisture barrier bag.

MSL2A = out of bag storage for 4 weeks at <30°C / 60% Relative Humidity. Supplied in moisture barrier bag.

MSL3 = out of bag storage for 168 hours at <30°C / 60% Relative Humidity. Supplied in moisture barrier bag.

The Moisture Sensitivity Level for each package type is specified in Ordering Information.

CONDITION	MIN	MAX
Supply Voltage (VDD)	-0.3V	+4.2V
Operating temperature range, T _A	-40°C	+100°C
Storage temperature prior to soldering	30°C max / 60% RH max	
Storage temperature after soldering	-40°C	+100°C

IMPORTANT ASSEMBLY GUIDELINES

Do not put a vacuum over the port hole of the microphone. Placing a vacuum over the port hole can damage the device.

Do not board wash the microphone after a re-flow process. Board washing and the associated cleaning agents can damage the device. Do not expose to ultrasonic cleaning methods.

Do not use a vapour phase re-flow process. The vapour can damage the device.

Please refer to application note WAN0273 (MEMS MIC Assembly and Handling Guidelines) for further assembly and handling guidelines.

RECOMMENDED OPERATING CONDITIONS

PARAMETER	SYMBOL	MIN	TYP	MAX	UNIT
Analog Supply Range	VDD	1.5		3.7	V
Ground	GND		0		V

ACOUSTIC AND ELECTRICAL CHARACTERISTICS

Test Conditions: VDD=2.1V, 1kHz test signal, T_A = 25°C, unless otherwise stated.

PARAMETER	SYMBOL	TEST CONDITIONS	MIN	TYP	MAX	UNIT
Directivity			Omni-directional			
Polarity		Positive sound pressure	Positive output voltage			
Sensitivity	S	94dB SPL	-39	-38	-37	dBV
Acoustic Overload		No Load, THD < 10%		126		dB SPL
Total Harmonic Distortion	THD	100dB SPL		0.1	1	%
		114dB SPL		0.2		
		122 dB SPL		1		
Signal to Noise Ratio	SNR	A-weighted		65		dB
Dynamic Range	DR	A-weighted		93		dB
Frequency Response		-3dB low frequency		62		Hz
		+3dB high frequency		12500		
Frequency Response Flatness		200Hz to 6kHz	-1		+1	dB
Acoustic Noise Floor		A-weighted		29		dB SPL
Electrical Noise Floor		A-weighted		-103		dBV
Power Supply Rejection Ratio	PSRR	217Hz sine wave, 100mV (peak-peak)		53		dB
Power Supply Rejection	PSR	217Hz square wave, 100mV (peak-peak)		-79		dBV
Current Consumption	I _{VDD}			190	240	μA
Output DC Impedance	Z _{OUT}			55	150	Ω

TERMINOLOGY

1. Sensitivity (dBV) - Sensitivity is a measure of the microphone output response to the acoustic pressure of a 1kHz 94dB SPL (1Pa RMS) sine wave.
2. Total Harmonic Distortion (%) – THD is the ratio of the RMS sum of the harmonic distortion products in the specified bandwidth (see note below) relative to the amplitude of the fundamental (ie. test frequency) output.
3. Signal-to-Noise Ratio (dB) – SNR is a measure of the difference in level between the output response of a 1kHz 94dB SPL sine wave and the idle noise output.
4. Dynamic Range (dB) – DR is the ratio of the 1% THD microphone output level (in response to a sine wave input) and the idle noise output level.
5. All performance measurements are carried out within a 20Hz to 20kHz bandwidth and, where noted, an A-weighted filter. Failure to use these filters will result in higher THD and lower SNR values than are found in the Acoustic and Electrical Characteristics. The low pass filter removes out of band noise.

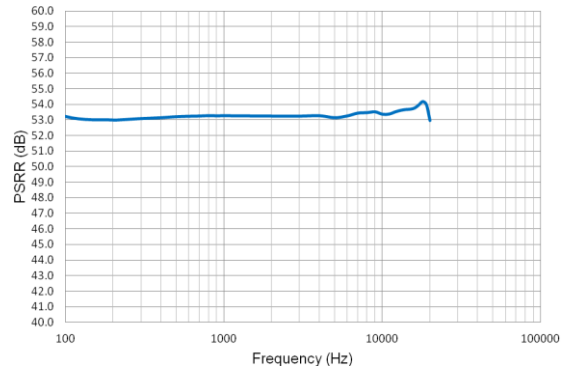
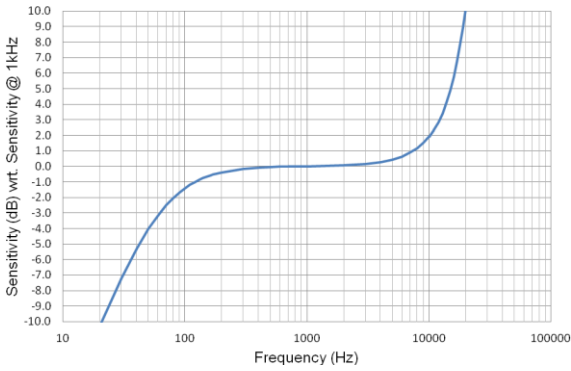
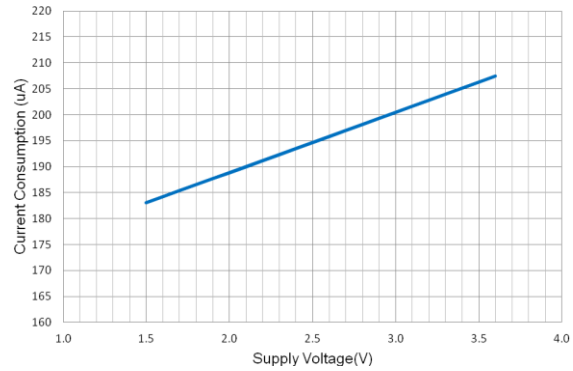
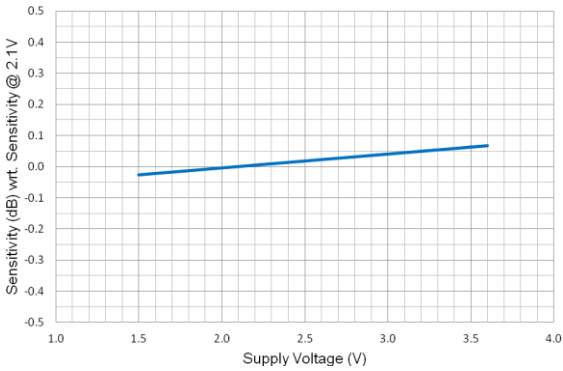
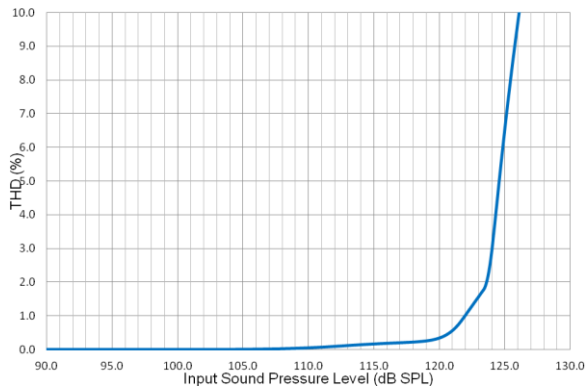
TYPICAL PERFORMANCE

Sensitivity vs. Frequency
PSRR vs. Frequency

Sensitivity vs. Supply Voltage
Current Consumption vs. Supply Voltage

THD vs. Sound Pressure Level

APPLICATIONS INFORMATION
RECOMMENDED EXTERNAL COMPONENTS

Figure 1 WM7132P Recommended External Components

A DC-blocking output capacitor is required on the OUTPUT pin, as illustrated in Figure 1. A single capacitor is required for a single-ended connection. The capacitor must be correctly selected as it affects the cut-off frequency of the output path. A low cut-off frequency is desirable as it means there is no significant filtering of the audio bandwidth.

The 3dB cut-off frequency of the output path is given by the equation below, where C is the output capacitance and R is the input resistance of the other circuit.

$$\text{3dB filter roll-off frequency} = \frac{1}{2\pi RC}$$

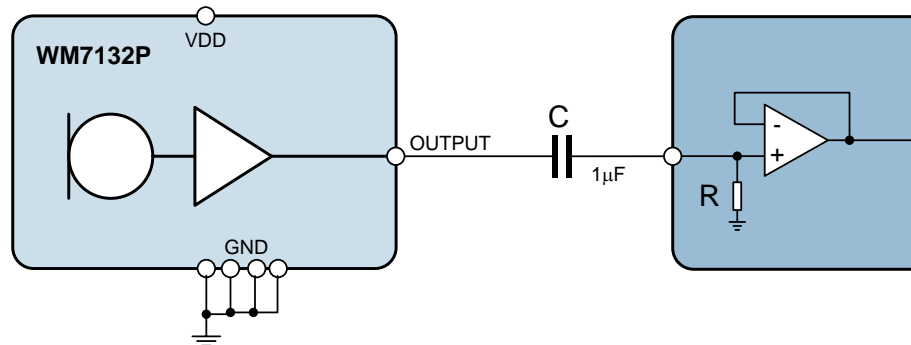
A typical recommended configuration, with 1µF DC-blocking capacitor and 20kΩ minimum input circuit impedance, gives a 3dB cut-off frequency of 10Hz or less. Tantalum electrolytic capacitors are particularly suitable for the DC-blocking components as they offer high stability in a small package size.

OPTIMISED SYSTEM RF DESIGN

For optimised RF design please refer to document WAN0278 (Recommended PCB Layout for Microphone RF Immunity in Mobile Cell Phone Applications) for further information.

CONNECTION TO A CIRRUS AUDIO CODEC

Cirrus provides a range of audio CODECs incorporating an analog microphone input interface; these support connection to silicon microphones such as the WM7132P.

The recommended connection of a WM7132P silicon microphone is illustrated in Figure 2 (for single-ended mode) and Figure 3 (for pseudo-differential mode).

A DC blocking capacitor is required, as described in the previous section. A 2.2µF decoupling capacitor is also recommended; this should be positioned close to the VDD pin of the WM7132P.

Further information on Cirrus audio CODECs is provided in the respective product datasheet, which is available from the Cirrus website.

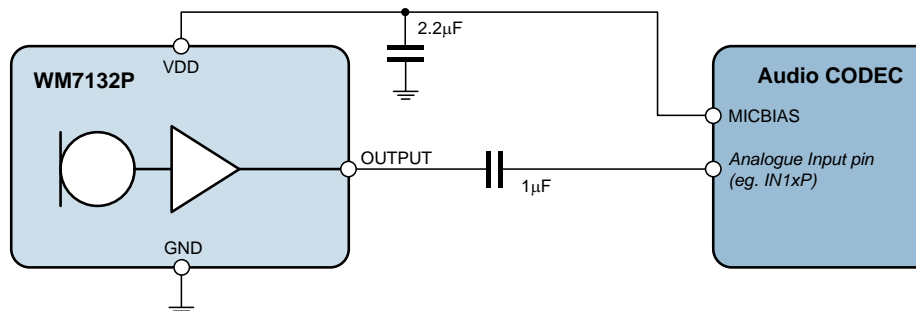

Figure 2 WM7132P Silicon Microphone Single-ended Connection

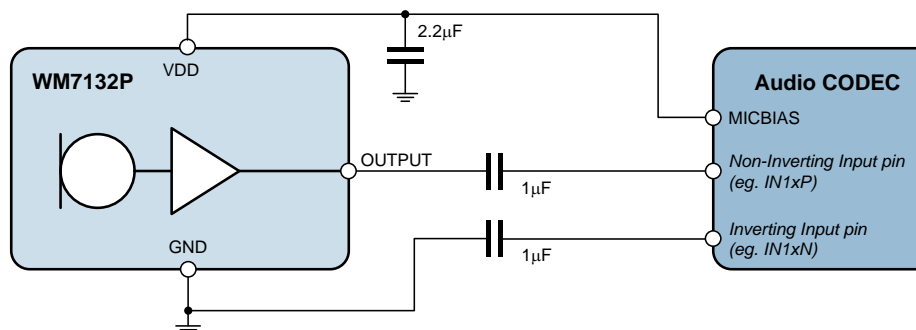

Figure 3 WM7132P Silicon Microphone Pseudo-differential Connection

MATCHED MICROPHONE PAIRS

The WM7132P Bottom Port microphone offers matched performance to the WM7121P Top Port microphone.

Matched microphone pairs are ideal for accurate sound pick-up from opposite directions in slim, low-profile applications. For best acoustic matching, the Top Port and Bottom Port microphones should be positioned close together, on the same side of the PCB.

The WM7132P and WM7121P microphones offer matched sensitivity, low-frequency roll-off, and phase response characteristics, enabling simplified system design when using these complementary devices.

PCB LAND PATTERN AND PASTE STENCIL

The recommended PCB Land Pattern and Paste Stencil for the WM7132P microphone are shown in Figure 4 and Figure 5.

See also Application Note WAN0284 (General Design Considerations for MEMS Microphones) for further details of PCB footprint design.

Full definition of the package dimensions is provided in the "Package Dimensions" section.

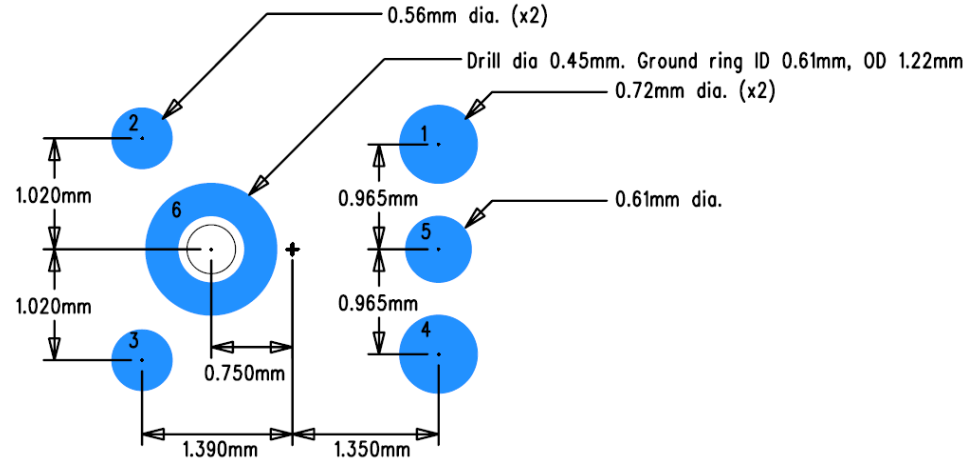

Figure 4 DM88 - PCB Land Pattern, Top View

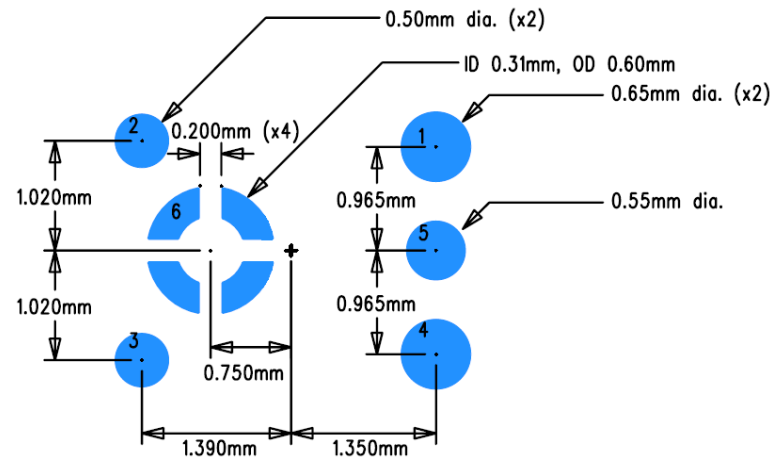
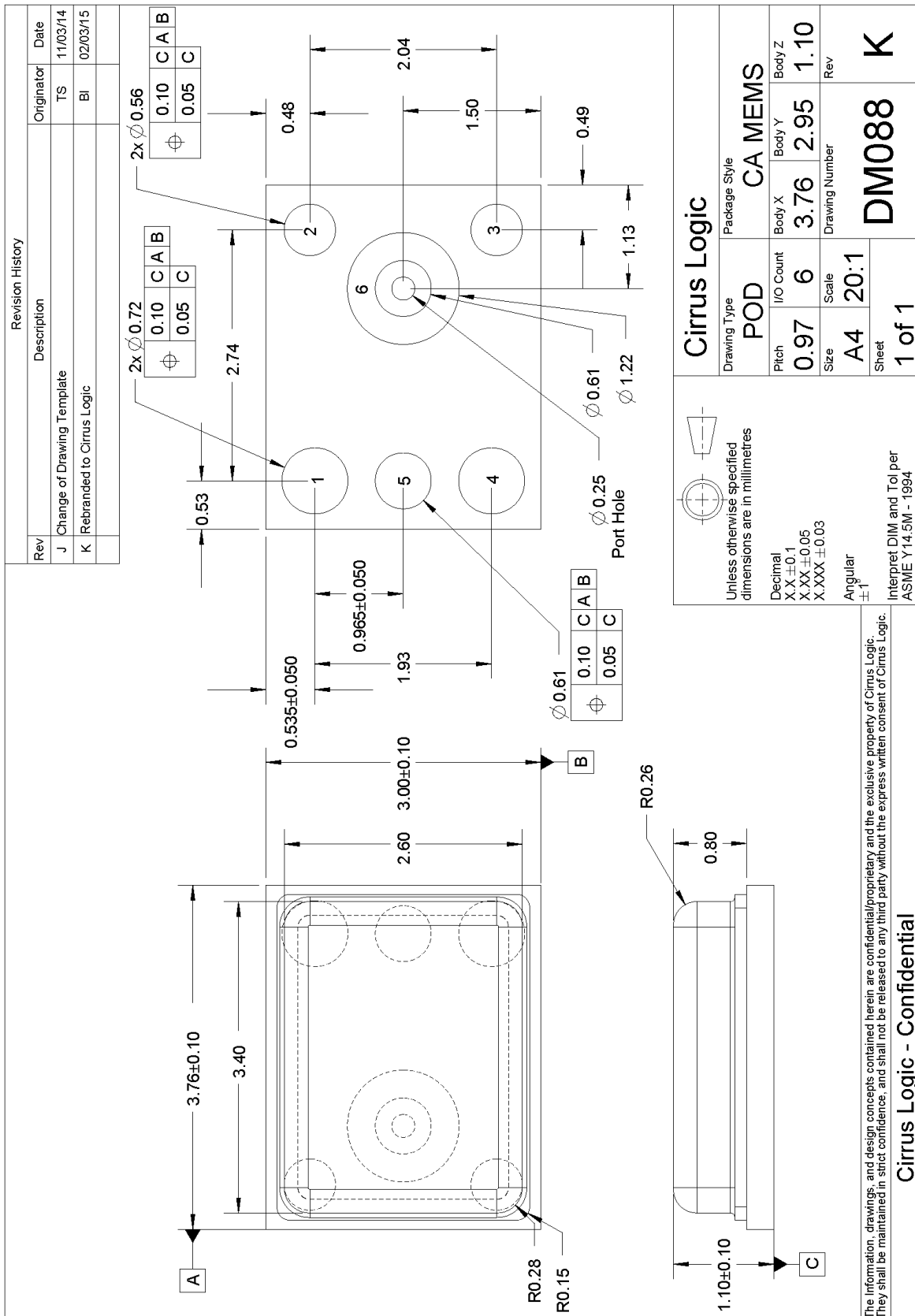

Figure 5 DM88 - Paste Stencil Pattern, Top View

PACKAGE DIMENSIONS



IMPORTANT NOTICE

Contacting Cirrus Logic Support

For all product questions and inquiries, contact a Cirrus Logic Sales Representative.

To find one nearest you, go to www.cirrus.com.

The products and services of Cirrus Logic International (UK) Limited; Cirrus Logic, Inc.; and other companies in the Cirrus Logic group (collectively either "Cirrus" or "Cirrus Logic") are sold subject to Cirrus's terms and conditions of sale supplied at the time of order acknowledgement, including those pertaining to warranty, indemnification, and limitation of liability. Software is provided pursuant to applicable license terms. Cirrus reserves the right to make changes to its products and specifications or to discontinue any product or service without notice. Customers should therefore obtain the latest version of relevant information from Cirrus to verify that the information is current and complete. Testing and other quality control techniques are utilized to the extent Cirrus deems necessary. Specific testing of all parameters of each device is not necessarily performed. In order to minimize risks associated with customer applications, the customer must use adequate design and operating safeguards to minimize inherent or procedural hazards. Cirrus is not liable for applications assistance or customer product design. The customer is solely responsible for its selection and use of Cirrus products.

CERTAIN APPLICATIONS USING SEMICONDUCTOR PRODUCTS MAY INVOLVE POTENTIAL RISKS OF DEATH, PERSONAL INJURY, OR SEVERE PROPERTY OR ENVIRONMENTAL DAMAGE ("CRITICAL APPLICATIONS"). CIRRUS PRODUCTS ARE NOT DESIGNED, AUTHORIZED OR WARRANTED FOR USE IN PRODUCTS SURGICALLY IMPLANTED INTO THE BODY, AUTOMOTIVE SAFETY OR SECURITY DEVICES, NUCLEAR SYSTEMS, LIFE SUPPORT PRODUCTS OR OTHER CRITICAL APPLICATIONS. INCLUSION OF CIRRUS PRODUCTS IN SUCH APPLICATIONS IS UNDERSTOOD TO BE FULLY AT THE CUSTOMER'S RISK AND CIRRUS DISCLAIMS AND MAKES NO WARRANTY, EXPRESS, STATUTORY OR IMPLIED, INCLUDING THE IMPLIED WARRANTIES OF MERCHANTABILITY AND FITNESS FOR PARTICULAR PURPOSE, WITH REGARD TO ANY CIRRUS PRODUCT THAT IS USED IN SUCH A MANNER. IF THE CUSTOMER OR CUSTOMER'S CUSTOMER USES OR PERMITS THE USE OF CIRRUS PRODUCTS IN CRITICAL APPLICATIONS, CUSTOMER AGREES, BY SUCH USE, TO FULLY INDEMNIFY CIRRUS, ITS OFFICERS, DIRECTORS, EMPLOYEES, DISTRIBUTORS AND OTHER AGENTS FROM ANY AND ALL LIABILITY, INCLUDING ATTORNEYS' FEES AND COSTS, THAT MAY RESULT FROM OR ARISE IN CONNECTION WITH THESE USES.

This document is the property of Cirrus and by furnishing this information, Cirrus grants no license, express or implied, under any patents, mask work rights, copyrights, trademarks, trade secrets or other intellectual property rights. Any provision or publication of any third party's products or services does not constitute Cirrus's approval, license, warranty or endorsement thereof. Cirrus gives consent for copies to be made of the information contained herein only for use within your organization with respect to Cirrus integrated circuits or other products of Cirrus, and only if the reproduction is without alteration and is accompanied by all associated copyright, proprietary and other notices and conditions (including this notice). This consent does not extend to other copying such as copying for general distribution, advertising or promotional purposes, or for creating any work for resale. This document and its information is provided "AS IS" without warranty of any kind (express or implied). All statutory warranties and conditions are excluded to the fullest extent possible. No responsibility is assumed by Cirrus for the use of information herein, including use of this information as the basis for manufacture or sale of any items, or for infringement of patents or other rights of third parties. Cirrus Logic, Cirrus, the Cirrus Logic logo design and SoundClear are among the trademarks of Cirrus. Other brand and product names may be trademarks or service marks of their respective owners.

Copyright © 2014–2015 Cirrus Logic, Inc. All rights reserved.

REVISION HISTORY

DATE	REV	DESCRIPTION OF CHANGES	PAGE	CHANGED BY
26/02/14	1.0	First Release		IS
25/03/14	2.0	Formatting and miscellaneous updates throughout document Electrical Characteristics updated Package Outline Drawing updated	1-9 5 10	PH
13/06/14	3.0	Electrical Characteristics updated Typical Performance graphs added PCB Stencil drawings updated	5 6 9	PH
13/03/15	4.0	Package Outline Drawing updated		PH