

24-bit, 192kHz Stereo CODEC with 5 Channel I/P Multiplexer

DESCRIPTION

The WM8776 is a high performance, stereo audio CODEC with five channel input selector. The WM8776 is ideal for surround sound processing applications for home hi-fi, DVD-RW and other audio visual equipment.

A stereo 24-bit multi-bit sigma delta ADC is used with a five stereo channel input mixer. Each ADC channel has programmable gain control with automatic level control. Digital audio output word lengths from 16-32 bits and sampling rates from 32kHz to 96kHz are supported.

A stereo 24-bit multi-bit sigma delta DAC is used with digital audio input word lengths from 16-32 bits and sampling rates from 32kHz to 192kHz. The DAC has an input mixer allowing an external analogue signal to be mixed with the DAC signal. There are also Headphone and line outputs, with volume controls for the headphones.

The WM8776 supports fully independent sample rates for the ADC and DAC. The audio data interface supports I²S, left justified, right justified and DSP formats.

The device is controlled in software via a 2 or 3 wire serial interface, selected by the MODE pin, which provides access to all features including channel selection, volume controls, mutes, and de-emphasis facilities.

The device is available in a 48-pin TQFP package.

BLOCK DIAGRAM

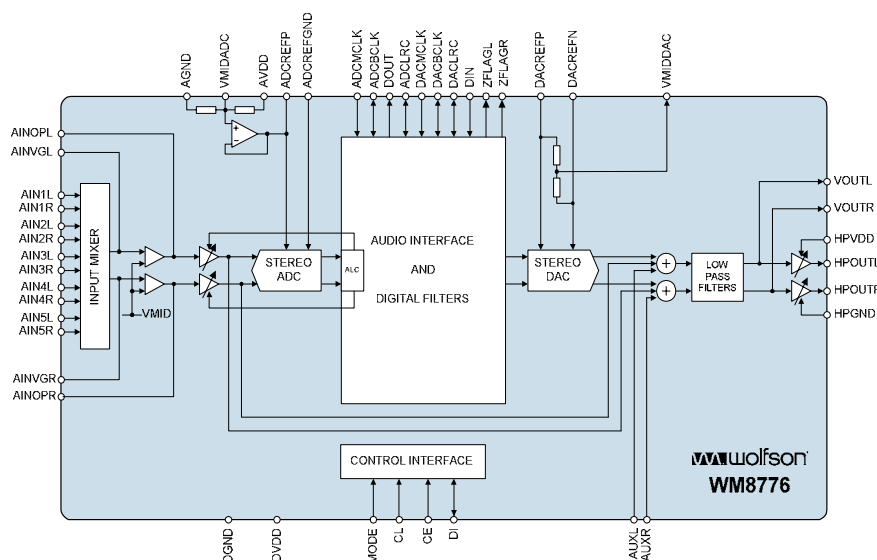

FEATURES

- Audio Performance
 - 108dB SNR ('A' weighted @ 48kHz) DAC
 - 102dB SNR ('A' weighted @ 48kHz) ADC
- DAC Sampling Frequency: 32kHz – 192kHz
- ADC Sampling Frequency: 32kHz – 96kHz
- Five stereo ADC inputs with analogue gain adjust from +24dB to –21dB in 0.5dB steps
- Programmable Limiter or Automatic Level Control (ALC)
- Stereo DAC with independent analogue and digital volume controls
- Stereo Headphone and Line Output
- 3-Wire SPI Compatible or 2-Wire Software Serial Control Interface
- Master or Slave Clocking Mode
- Programmable Audio Data Interface Modes
 - I²S, Left, Right Justified or DSP
 - 16/20/24/32 bit Word Lengths
- Analogue Bypass Path Feature
- Selectable AUX input to the volume controls
- 2.7V to 5.5V Analogue, 2.7V to 3.6V Digital supply Operation

APPLICATIONS

- Surround Sound AV Processors and Hi-Fi systems
- DVD-RW

TABLE OF CONTENTS

| | |
|--|-----------|
| DESCRIPTION | 1 |
| FEATURES..... | 1 |
| APPLICATIONS | 1 |
| BLOCK DIAGRAM | 1 |
| TABLE OF CONTENTS | 2 |
| PIN CONFIGURATION..... | 3 |
| ORDERING INFORMATION | 3 |
| PIN DESCRIPTION | 4 |
| ABSOLUTE MAXIMUM RATINGS..... | 5 |
| ELECTRICAL CHARACTERISTICS | 6 |
| TERMINOLOGY | 7 |
| MASTER CLOCK TIMING..... | 9 |
| DIGITAL AUDIO INTERFACE – MASTER MODE | 10 |
| DIGITAL AUDIO INTERFACE – SLAVE MODE | 11 |
| 3-WIRE MPU INTERFACE TIMING | 12 |
| CONTROL INTERFACE TIMING – 2-WIRE MODE | 13 |
| INTERNAL POWER ON RESET CIRCUIT | 14 |
| DEVICE DESCRIPTION..... | 16 |
| INTRODUCTION..... | 16 |
| AUDIO DATA SAMPLING RATES..... | 17 |
| ZERO DETECT | 18 |
| POWERDOWN MODES | 18 |
| DIGITAL AUDIO INTERFACE | 19 |
| CONTROL INTERFACE OPERATION..... | 23 |
| CONTROL INTERFACE REGISTERS | 25 |
| LIMITER / AUTOMATIC LEVEL CONTROL (ALC)..... | 34 |
| REGISTER MAP | 41 |
| DIGITAL FILTER CHARACTERISTICS | 49 |
| DAC FILTER RESPONSES..... | 49 |
| ADC FILTER RESPONSES..... | 50 |
| ADC HIGH PASS FILTER | 51 |
| DIGITAL DE-EMPHASIS CHARACTERISTICS..... | 52 |
| APPLICATIONS INFORMATION | 53 |
| EXTERNAL CIRCUIT CONFIGURATION | 53 |
| RECOMMENDED EXTERNAL COMPONENTS | 54 |
| PACKAGE DIMENSIONS | 56 |
| PACKAGE DIMENSIONS | 56 |
| IMPORTANT NOTICE | 57 |
| ADDRESS:..... | 57 |

PIN CONFIGURATION

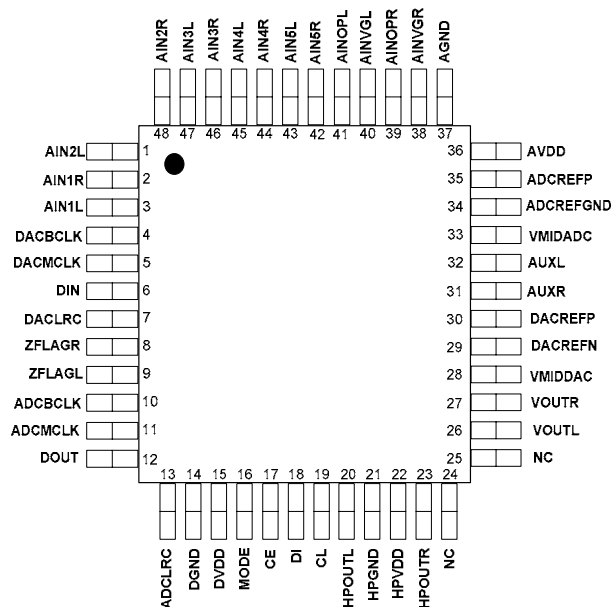

ORDERING INFORMATION

| DEVICE | TEMPERATURE RANGE | PACKAGE | MOISTURE SENSITIVITY LEVEL | PEAK SOLDERING TEMPERATURE |
|---------------|-------------------|--------------------------------------|----------------------------|----------------------------|
| WM8776SEFT/V | -25 to +85°C | 48-pin TQFP (Pb-free) | MSL2 (drybagged) | 260°C |
| WM8776SEFT/RV | -25 to +85°C | 48-pin TQFP (Pb-free, tape and reel) | MSL2 (drybagged) | 260°C |

Note:

Reel quantity = 2,200

PIN DESCRIPTION

| PIN | NAME | TYPE | DESCRIPTION |
|-----|-----------|----------------------|--|
| 1 | AIN2L | Analogue Input | Channel 2 left input multiplexor virtual ground |
| 2 | AIN1R | Analogue Input | Channel 1 right input multiplexor virtual ground |
| 3 | AIN1L | Analogue Input | Channel 1 left input multiplexor virtual ground |
| 4 | DACBCLK | Digital input/output | DAC audio interface bit clock |
| 5 | DACMCLK | Digital input | Master DAC clock; 256, 384, 512 or 768fs (fs = word clock frequency) |
| 6 | DIN | Digital Input | DAC data input |
| 7 | DACLRC | Digital input/output | DAC left/right word clock |
| 8 | ZFLAGR | Open Drain output | DAC Right Zero Flag output (external pull-up resistor required) |
| 9 | ZFLAGL | Open Drain output | DAC Left Zero Flag output (external pull-up resistor required) |
| 10 | ADCBCLK | Digital input/output | ADC audio interface bit clock |
| 11 | ADCMCLK | Digital input | ADC audio interface master clock |
| 12 | DOUT | Digital output | ADC data output |
| 13 | ADCLRC | Digital input/output | ADC left/right word clock |
| 14 | DGND | Supply | Digital negative supply |
| 15 | DVDD | Supply | Digital positive supply |
| 16 | MODE | Digital input | Control interface mode select |
| 17 | CE | Digital input | Serial interface Latch signal |
| 18 | DI | Digital input | Serial interface data |
| 19 | CL | Digital input | Serial interface clock |
| 20 | HPOUTL | Analogue Output | Headphone left channel output |
| 21 | HPGND | Supply | Headphone negative supply |
| 22 | HPVDD | Supply | Headphone positive supply |
| 23 | HPOUTR | Analogue Output | Headphone right channel output |
| 24 | NC | Not bonded | |
| 25 | NC | Not bonded | |
| 26 | VOUTL | Analogue output | DAC channel left output |
| 27 | VOUTR | Analogue output | DAC channel right output |
| 28 | VMIDDAC | Analogue output | DAC midrail decoupling pin ; 10uF external decoupling |
| 29 | DACREFN | Analogue input | DAC negative reference input |
| 30 | DACREFP | Analogue input | DAC positive reference input |
| 31 | AUXR | Analogue input | DAC mixer right channel input |
| 32 | AUXL | Analogue input | DAC mixer left channel input |
| 33 | VMIDADC | Analogue Output | ADC midrail divider decoupling pin; 10uF external decoupling |
| 34 | ADCREFGND | Supply | ADC negative supply and substrate connection |
| 35 | ADCREFP | Analogue Output | ADC positive reference decoupling pin; 10uF external decoupling |
| 36 | AVDD | Supply | Analogue positive supply |
| 37 | AGND | Supply | Analogue negative supply and subVstrate connection |
| 38 | AINVGR | Analogue Input | Right channel multiplexor virtual ground |
| 39 | AINOPR | Analogue Output | Right channel multiplexor output |
| 40 | AINVGL | Analogue Input | Left channel multiplexor virtual ground |
| 41 | AINOPL | Analogue Output | Left channel multiplexor output |
| 42 | AIN5R | Analogue Input | Channel 5 right input multiplexor virtual ground |
| 43 | AIN5L | Analogue Input | Channel 5 left input multiplexor virtual ground |
| 44 | AIN4R | Analogue Input | Channel 4 right input multiplexor virtual ground |
| 45 | AIN4L | Analogue Input | Channel 4 left input multiplexor virtual ground |
| 46 | AIN3R | Analogue Input | Channel 3 right input multiplexor virtual ground |
| 47 | AIN3L | Analogue Input | Channel 3 left input multiplexor virtual ground |
| 48 | AIN2R | Analogue Input | Channel 2 right input multiplexor virtual ground |

Note : Digital input pins have Schmitt trigger input buffers.

ABSOLUTE MAXIMUM RATINGS

Absolute Maximum Ratings are stress ratings only. Permanent damage to the device may be caused by continuously operating at or beyond these limits. Device functional operating limits and guaranteed performance specifications are given under Electrical Characteristics at the test conditions specified.



ESD Sensitive Device. This device is manufactured on a CMOS process. It is therefore generically susceptible to damage from excessive static voltages. Proper ESD precautions must be taken during handling and storage of this device.

Wolfson tests its package types according to IPC/JEDEC J-STD-020B for Moisture Sensitivity to determine acceptable storage conditions prior to surface mount assembly. These levels are:

MSL1 = unlimited floor life at <30°C / 85% Relative Humidity. Not normally stored in moisture barrier bag.

MSL2 = out of bag storage for 1 year at <30°C / 60% Relative Humidity. Supplied in moisture barrier bag.

MSL3 = out of bag storage for 168 hours at <30°C / 60% Relative Humidity. Supplied in moisture barrier bag.

The Moisture Sensitivity Level for each package type is specified in Ordering Information.

| CONDITION | MIN | MAX |
|---|------------|-------------|
| Digital supply voltage | -0.3V | +3.63V |
| Analogue supply voltage | -0.3V | +7V |
| Voltage range digital inputs (MCLK, DIN, ADCLRC, DACLRC, ADCBCLK, DACBCLK, DI, CL, CE and MODE) | DGND -0.3V | DVDD + 0.3V |
| Voltage range analogue inputs | AGND -0.3V | AVDD +0.3V |
| Master Clock Frequency | | 37MHz |
| Operating temperature range, T _A | -25°C | +85°C |
| Storage temperature | -65°C | +150°C |

Notes:

- Analogue and digital grounds must always be within 0.3V of each other.

RECOMMENDED OPERATING CONDITIONS

| PARAMETER | SYMBOL | TEST CONDITIONS | MIN | TYP | MAX | UNIT |
|-------------------------|--------------------------------|-----------------|------|-----|------|------|
| Digital supply range | DVDD | | 2.7 | | 3.6 | V |
| Analogue supply range | AVDD, HPVDD, DACREFP | | 2.7 | | 5.5 | V |
| Ground | AGND, DGND, DACREFN, ADCREFGND | | | 0 | | V |
| Difference DGND to AGND | | | -0.3 | 0 | +0.3 | V |

Note: digital supply DVDD must never be more than 0.3V greater than AVDD.

ELECTRICAL CHARACTERISTICS

Test Conditions

AVDD = 5V, DVDD = 3.3V, AGND = 0V, DGND = 0V, T_A = +25°C, fs = 48kHz, MCLK = 256fs unless otherwise stated.

| PARAMETER | SYMBOL | TEST CONDITIONS | MIN | TYP | MAX | UNIT |
|---|-------------------|---|------------|--------------|------------|------------------|
| Digital Logic Levels (TTL Levels) | | | | | | |
| Input LOW level | V _{IL} | | | | 0.8 | V |
| Input HIGH level | V _{IH} | | 2.0 | | | V |
| Output LOW | V _{OL} | I _{OL} =1mA | | | 0.1 x DVDD | V |
| Output HIGH | V _{OH} | I _{OH} =1mA | 0.9 x DVDD | | | V |
| Analogue Reference Levels | | | | | | |
| Reference voltage | V _{VMID} | | | AVDD/2 | | V |
| Potential divider resistance | R _{VMID} | | | 50k | | Ω |
| DAC Performance (Load = 10k Ω, 50pF) | | | | | | |
| 0dBfs Full scale output voltage | | | | 1.0 x AVDD/5 | | V _{rms} |
| SNR (Note 1,2) | | A-weighted, @ fs = 48kHz | 102 | 108 | | dB |
| SNR (Note 1,2) | | A-weighted @ fs = 96kHz | | 108 | | dB |
| Dynamic Range (Note 2) | DNR | A-weighted, -60dB full scale input | | 108 | | dB |
| Total Harmonic Distortion (THD) | | 1kHz, 0dBfs | | -97 | -90 | dB |
| DAC channel separation | | | | 100 | | dB |
| Power Supply Rejection Ratio | PSRR | 1kHz 100mVpp | | 50 | | dB |
| | | 20Hz to 20kHz 100mVpp | | 45 | | dB |
| Headphone Buffer | | | | | | |
| Maximum Output voltage | | | | 0.9 | | V _{rms} |
| Max Output Power (Note 4) | P _o | R _L = 32 Ω | | 25 | | mW |
| | | R _L = 16 Ω | | 50 | | mW |
| SNR (Note 1,2) | | A-weighted | 85 | 92 | | dB |
| Headphone analogue Volume Gain Step Size | | | 0.5 | 1 | 1.5 | dB |
| Headphone analogue Volume Gain Range | | 1kHz Input | -73 | | +6 | dB |
| Headphone analogue Volume Mute Attenuation | | 1kHz Input, 0dB gain | | 100 | | dB |
| Total Harmonic Distortion | THD | 1kHz, R _L = 32Ω @ P _o = 10mW rms | | -80 0.01 | -60 0.1 | dB % |
| | | 1kHz, R _L = 32Ω @ P _o = 20mW rms | | -77 0.014 | -55 1.0 | dB % |
| Power Supply Rejection Ratio | PSRR | 20Hz to 20kHz, without supply decoupling | | -40 | | dB |
| ADC Performance | | | | | | |
| Input Signal Level (0dB) | | | | 1.0 x AVDD/5 | | V _{rms} |
| SNR (Note 1,2) | | A-weighted, 0dB gain @ fs = 48kHz | 97 | 102 | | dB |
| SNR (Note 1,2) | | A-weighted, 0dB gain @ fs = 96kHz 64 x OSR | | 100 | | dB |
| Dynamic Range (note 2) | | A-weighted, -60dB full scale input | | 102 | | dB |
| Total Harmonic Distortion (THD) | | 1kHz, 0dBfs | | -92 | | dB |

Test ConditionsAVDD = 5V, DVDD = 3.3V, AGND = 0V, DGND = 0V, T_A = +25°C, fs = 48kHz, MCLK = 256fs unless otherwise stated.

| | | | | | | |
|---|------|--------------------------|------|-----------------|-------|------|
| | | 1kHz, -1dBfs | | -95 | -85 | dB |
| ADC Channel Separation | | 1kHz Input | | 90 | | dB |
| Programmable Gain Step Size | | | 0.25 | 0.5 | 0.75 | dB |
| Programmable Gain Range (Analogue) | | 1kHz Input | -21 | | +24 | dB |
| Programmable Gain Range (Digital) | | 1kHz Input | -103 | | -21.5 | dB |
| Analogue Mute Attenuation (Note 6) | | 1kHz Input, 0dB gain | | 76 | | dB |
| Power Supply Rejection Ratio | PSRR | 1kHz 100mVpp | | 50 | | dB |
| | | 20Hz to 20kHz 100mVpp | | 45 | | dB |
| Analogue Input (AIN) to Analogue output (VOUT) (Load=10kΩ, 50pF, gain = 0dB) Bypass Mode | | | | | | |
| 0dB Full scale output voltage | | | | 1.0 x AVDD/5 | | Vrms |
| SNR (Note 1) | | | 99 | 103 | | dB |
| THD | | 1kHz, 0dB | | -93 | | dB |
| | | 1kHz, -3dB | | -95 | | dB |
| Power Supply Rejection Ratio | PSRR | 1kHz 100mVpp | | 50 | | dB |
| | | 20Hz to 20kHz 100mVpp | | 45 | | dB |
| Mute Attenuation | | 1kHz, 0dB | | 100 | | dB |
| Supply Current | | | | | | |
| Analogue supply current | | AVDD = 5V | | 48 | | mA |
| Digital supply current | | DVDD = 3.3V | | 8 | | mA |
| Aux Input (AUX/L/R) to Analogue output (VOUT L/R) (Load=10kΩ, 50pF, gain = 0dB) | | | | | | |
| SNR | | | | 108 | | dB |
| THD | | | | -95 | | dB |

Notes:

- Ratio of output level with 1kHz full scale input, to the output level with all zeros into the digital input, measured 'A' weighted.
- All performance measurements done with 20kHz low pass filter, and where noted an A-weight filter. Failure to use such a filter will result in higher THD+N and lower SNR and Dynamic Range readings than are found in the Electrical Characteristics. The low pass filter removes out of band noise; although it is not audible it may affect dynamic specification values.
- VMIID decoupled with 10uF and 0.1uF capacitors (smaller values may result in reduced performance).
- Harmonic distortion on the headphone output decreases with output power.
- All performance measurement done using certain timings conditions (Please refer to section 'Digital Audio Interface').
- A full digital MUTE can be achieved if the ADC gain (LAG/RAG) is set to minimum.

TERMINOLOGY

- Signal-to-noise ratio (dB) - SNR is a measure of the difference in level between the full scale output and the output with no signal applied. (No Auto-zero or Automute function is employed in achieving these results).
- Dynamic range (dB) - DNR is a measure of the difference between the highest and lowest portions of a signal. Normally a THD+N measurement at 60dB below full scale. The measured signal is then corrected by adding the 60dB to it. (e.g. THD+N @ -60dB = -32dB, DR = 92dB).
- THD+N (dB) - THD+N is a ratio, of the rms values, of (Noise + Distortion)/Signal.
- Stop band attenuation (dB) - Is the degree to which the frequency spectrum is attenuated (outside audio band).

-
5. Channel Separation (dB) - Also known as Cross-Talk. This is a measure of the amount one channel is isolated from the other. Normally measured by sending a full scale signal down one channel and measuring the other.
 6. Pass-Band Ripple - Any variation of the frequency response in the pass-band region.

MASTER CLOCK TIMING

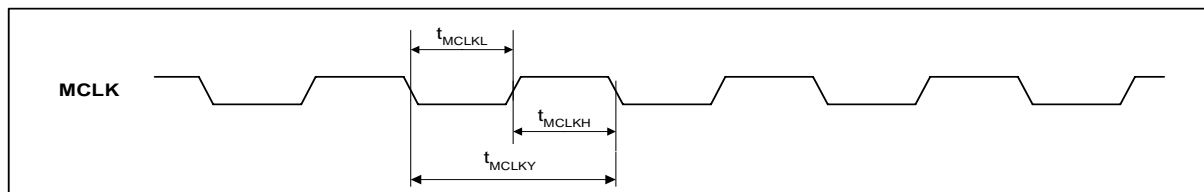

Figure 1 Master Clock Timing Requirements

Test Conditions

AVDD = 5V, DVDD = 3.3V, AGND = 0V, DGND = 0V, $T_A = +25^\circ\text{C}$, $f_s = 48\text{kHz}$, ADC/DACMCLK = 256fs unless otherwise stated.

| PARAMETER | SYMBOL | TEST CONDITIONS | MIN | TYP | MAX | UNIT |
|---|-------------|-----------------------|-------|-----|-------|---------------|
| System Clock Timing Information | | | | | | |
| ADC/DACMCLK System clock pulse width high | t_{MCLKH} | | 11 | | | ns |
| ADC/DACMCLK System clock pulse width low | t_{MCLKL} | | 11 | | | ns |
| ADC/DACMCLK System clock cycle time | t_{MCLKY} | | 28 | | 1000 | ns |
| ADC/DACMCLK Duty cycle | | | 40:60 | | 60:40 | |
| Power-saving mode activated | | After MCLK stopped | 2 | | 10 | μs |
| Normal mode resumed | | After MCLK re-started | 0.5 | | 1 | MCLK cycle |

Table 1 Master Clock Timing Requirements

Note:

If MCLK period is longer than maximum specified above, power-saving mode is entered and DACs are powered down with internal digital audio filters being reset. In this power-saving mode, all registers will retain their values and can be accessed in the normal manner through the control interface. Once MCLK is restored, the DACs are automatically powered up, but a write to the volume update register bit is required to restore the correct volume settings.

DIGITAL AUDIO INTERFACE – MASTER MODE

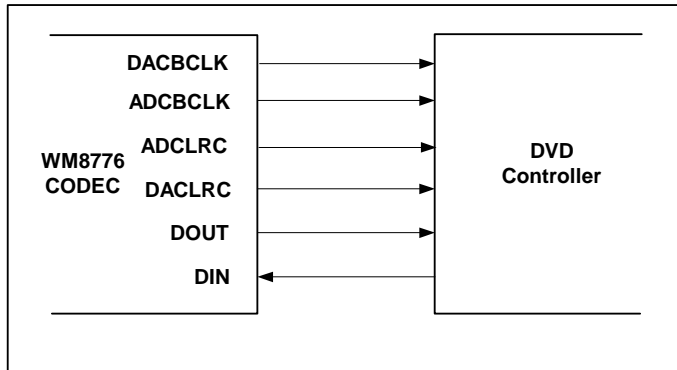

Figure 2 Audio Interface - Master Mode

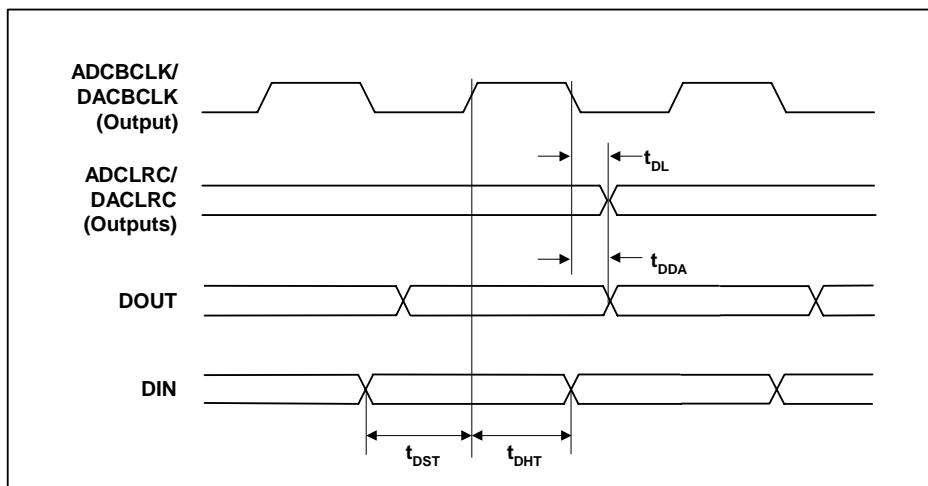

Figure 3 Digital Audio Data Timing – Master Mode

Test Conditions

AVDD = 5V, DVDD = 3.3V, AGND, DGND = 0V, TA = +25°C, Master Mode, fs = 48kHz, ADC/DACMCLK = 256fs unless otherwise stated.

| PARAMETER | SYMBOL | TEST CONDITIONS | MIN | TYP | MAX | UNIT |
|--|------------------|-----------------|-----|-----|-----|------|
| Audio Data Input Timing Information | | | | | | |
| ADC/DACLRC propagation delay from ADC/DACBCLK falling edge | t _{DL} | | 0 | | 10 | ns |
| DOUT propagation delay from ADCBCLK falling edge | t _{DDA} | | 0 | | 10 | ns |
| DIN setup time to DACBCLK rising edge | t _{DST} | | 10 | | | ns |
| DIN hold time from DACBCLK rising edge | t _{DHT} | | 10 | | | ns |

Table 2 Digital Audio Data Timing – Master Mode

DIGITAL AUDIO INTERFACE – SLAVE MODE

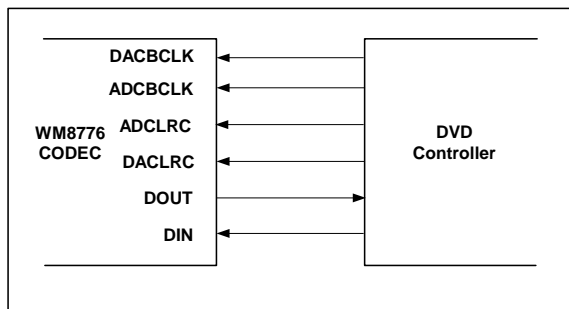

Figure 4 Audio Interface – Slave Mode

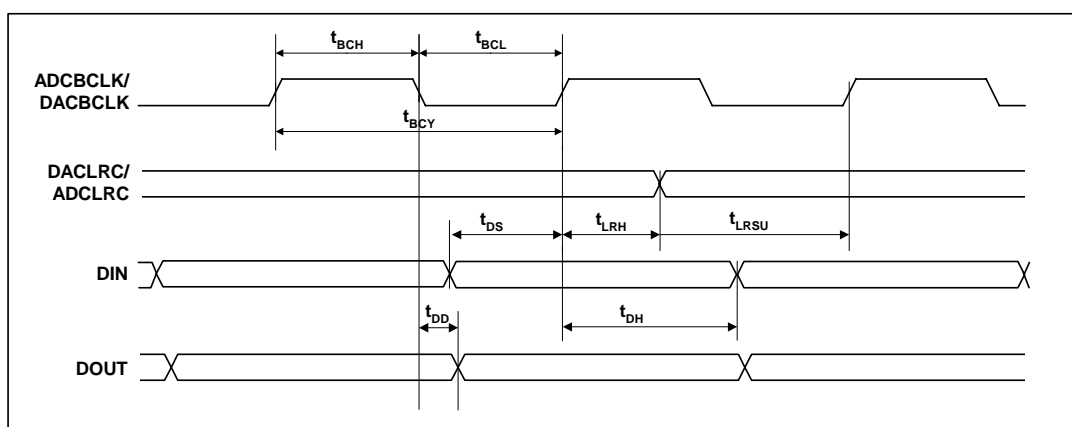

Figure 5 Digital Audio Data Timing – Slave Mode

Test Conditions

AVDD = 5V, DVDD = 3.3V, AGND = 0V, DGND = 0V, T_A = +25°C, Slave Mode, fs = 48kHz, ADC/DACMCLK = 256fs unless otherwise stated.

| PARAMETER | SYMBOL | TEST CONDITIONS | MIN | TYP | MAX | UNIT |
|--|-------------------|-----------------|-----|-----|-----|------|
| Audio Data Input Timing Information | | | | | | |
| ADC/DACBCLK cycle time | t _{BCY} | | 50 | | | ns |
| ADC/DACBCLK pulse width high | t _{BCH} | | 20 | | | ns |
| ADC/DACBCLK pulse width low | t _{BCL} | | 20 | | | ns |
| DACLRC/ADCLRC set-up time to ADC/DACBCLK rising edge | t _{LRSU} | | 10 | | | ns |
| DACLRC/ADCLRC hold time from ADC/DACBCLK rising edge | t _{LRH} | | 10 | | | ns |
| DIN set-up time to DACBCLK rising edge | t _{DS} | | 10 | | | ns |
| DIN hold time from DACBCLK rising edge | t _{DH} | | 10 | | | ns |
| DOUT propagation delay from ADCBCLK falling edge | t _{DD} | | 0 | | 10 | ns |

Table 3 Digital Audio Data Timing – Slave Mode

Note: ADCLRC and DACLRC should be synchronous with MCLK, although the WM8776 interface is tolerant of phase variations or jitter on these signals.

3-WIRE MPU INTERFACE TIMING

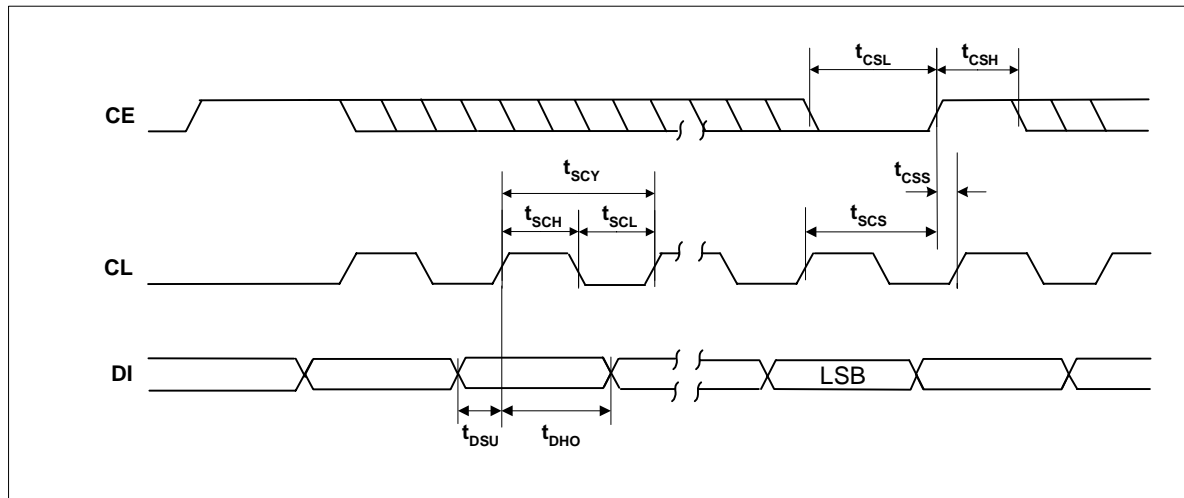

Figure 6 SPI Compatible (3-wire) Control Interface Input Timing (MODE=1)

| Test Conditions | | | | | |
|---|------------------|-----|-----|-----|------|
| AVDD = 5V, DVDD = 3.3V, AGND, DGND = 0V, T _A = +25°C, f _s = 48kHz, MCLK = 256fs unless otherwise stated | | | | | |
| PARAMETER | SYMBOL | MIN | TYP | MAX | UNIT |
| CL rising edge to CE rising edge | t _{SCS} | 60 | | | ns |
| CL pulse cycle time | t _{SCY} | 80 | | | ns |
| CL pulse width low | t _{SCL} | 30 | | | ns |
| CL pulse width high | t _{SCH} | 30 | | | ns |
| DI to CL set-up time | t _{DSU} | 20 | | | ns |
| CL to DI hold time | t _{DHO} | 20 | | | ns |
| CE pulse width low | t _{CSL} | 20 | | | ns |
| CE pulse width high | t _{CSH} | 20 | | | ns |
| CE rising to CL rising | t _{CSS} | 20 | | | ns |

Table 4 3-wire SPI Compatible Control Interface Input Timing Information

CONTROL INTERFACE TIMING – 2-WIRE MODE

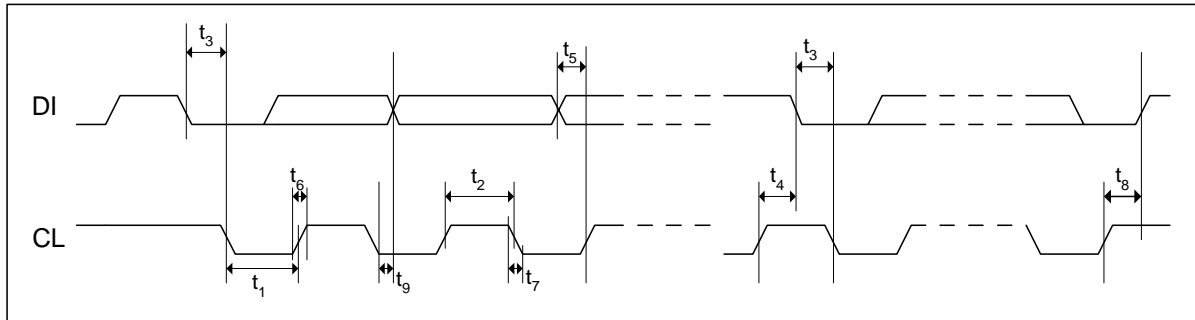

Figure 7 Control Interface Timing – 2-Wire Serial Control Mode (MODE=0)

Test Conditions

AVDD = 5V, DVDD = 3.3V, AGND, DGND = 0V, $T_A = +25^\circ\text{C}$, $f_s = 48\text{kHz}$, MCLK = 256fs unless otherwise stated

| PARAMETER | SYMBOL | MIN | TYP | MAX | UNIT |
|---|----------|-----|-----|-----|------|
| Program Register Input Information | | | | | |
| CL Frequency | | 0 | | 526 | kHz |
| CL Low Pulse-Width | t_1 | 1.3 | | | us |
| CL High Pulse-Width | t_2 | 600 | | | ns |
| Hold Time (Start Condition) | t_3 | 600 | | | ns |
| Setup Time (Start Condition) | t_4 | 600 | | | ns |
| Data Setup Time | t_5 | 100 | | | ns |
| DI, CL Rise Time | t_6 | | | 300 | ns |
| DI, CL Fall Time | t_7 | | | 300 | ns |
| Setup Time (Stop Condition) | t_8 | 600 | | | ns |
| Data Hold Time | t_9 | | | 900 | ns |
| Pulse width of spikes that will be suppressed | t_{ps} | 0 | | 5 | ns |

Table 5 2-wire Control Interface Timing Information

INTERNAL POWER ON RESET CIRCUIT

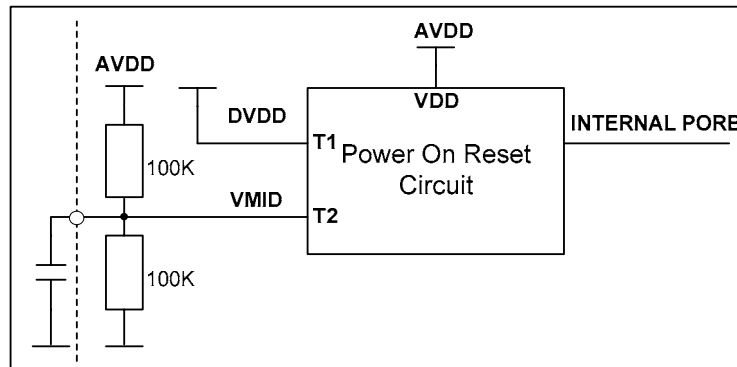

Figure 8 Internal Power on Reset Circuit Schematic

The WM8776 includes an internal Power on Reset Circuit which is used reset the digital logic into a default state after power up.

Figure 8 shows a schematic of the internal POR circuit. The POR circuit is powered from AVDD. The circuit monitors DVDD and VMID and asserts PORB low if DVDD or VMID are below the minimum threshold V_{por_off} .

On power up, the POR circuit requires AVDD to be present to operate. PORB is asserted low until AVDD and DVDD and VMID are established. When AVDD, DVDD, and VMID have been established, PORB is released high, all registers are in their default state and writes to the digital interface may take place.

On power down, PORB is asserted low whenever DVDD or VMID drop below the minimum threshold V_{por_off} .

If AVDD is removed at any time, the internal Power on Reset circuit is powered down and PORB will follow AVDD.

In most applications the time required for the device to release PORB high will be determined by the charge time of the VMID node.

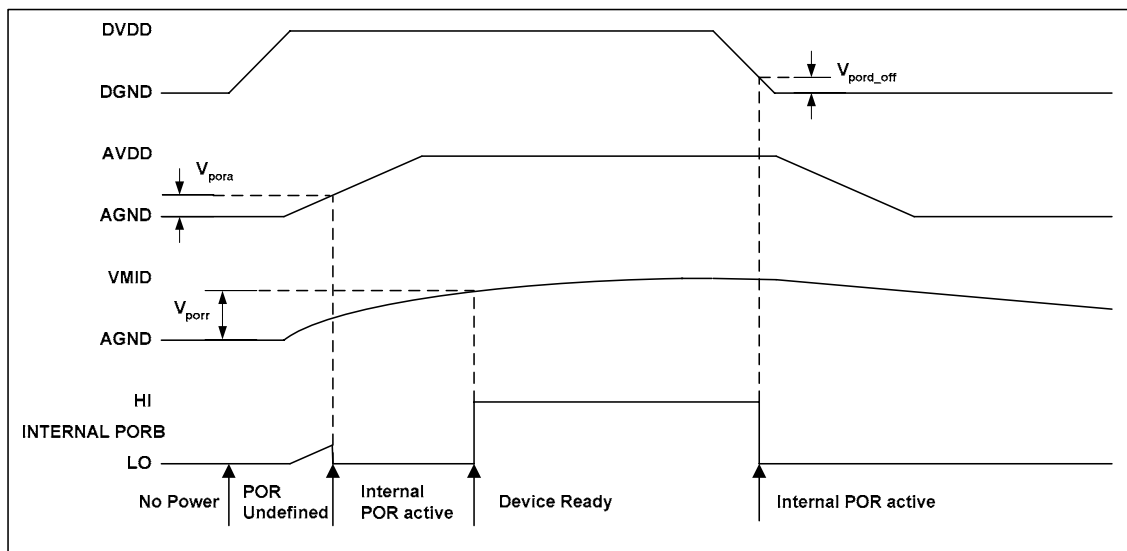

Figure 9 Typical Power up Sequence where DVDD is Powered before AVDD

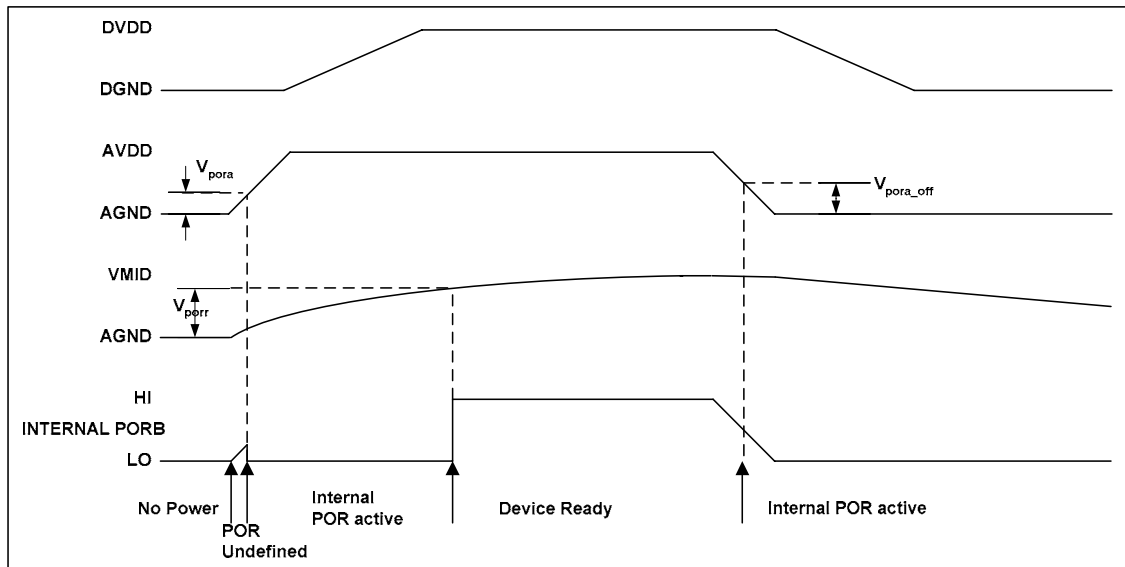

Figure 10 Typical Power up Sequence where AVDD is Powered before DVDD

Typical POR Operation (typical values, not tested)

| SYMBOL | MIN | TYP | MAX | UNIT |
|-----------------|-----|-----|-----|------|
| V_{pora} | 0.5 | 0.7 | 1.0 | V |
| V_{porr} | 0.5 | 0.7 | 1.1 | V |
| V_{pora_off} | 1.0 | 1.4 | 2.0 | V |
| V_{pord_off} | 0.6 | 0.8 | 1.0 | V |

In a real application the designer is unlikely to have control of the relative power up sequence of AVDD and DVDD. Using the POR circuit to monitor VMID ensures a reasonable delay between applying power to the device and Device Ready.

Figure 9 and Figure 10 show typical power up scenarios in a real system. Both AVDD and DVDD must be established and VMID must have reached the threshold V_{porr} before the device is ready and can be written to. Any writes to the device before Device Ready will be ignored.

Figure 9 shows DVDD powering up before AVDD. Figure 10 shows AVDD powering up before DVDD. In both cases, the time from applying power to Device Ready is dominated by the charge time of VMID.

A 10uF cap is recommended for decoupling on VMID. The charge time for VMID will dominate the time required for the device to become ready after power is applied. The time required for VMID to reach the threshold is a function of the VMID resistor string and the decoupling capacitor. The Resistor string has a typical equivalent resistance of 50kΩ (+/-20%). Assuming a 10uF capacitor, the time required for VMID to reach threshold of 1V is approx 110ms.

DEVICE DESCRIPTION

INTRODUCTION

WM8776 is a complete 2-channel DAC, 2-channel ADC audio CODEC, with flexible input multiplexor including digital interpolation and decimation filters, multi-bit sigma delta stereo ADC, and switched capacitor multi-bit sigma delta DACs with analogue volume controls on each channel and output smoothing filters. It is available in a single package and controlled by either a 3-wire or 2-wire software interface. The 3-wire interface is compatible with the SPI standard.

An analogue bypass path option is available, to allow stereo analogue signals from any of the 5 stereo inputs to be sent to the stereo outputs via the main volume controls. This allows a purely analogue input to analogue output high quality signal path to be implemented if required.

The DAC and ADC have separate left/right clocks, bit clocks, master clocks and data I/Os. The Audio Interface may be configured to operate in either master or slave mode. In Slave mode ADCLRC, DACLRC, ADCBCLK and DACBCLK are all inputs. In Master mode ADCLRC, DACLRC, ADCBCLK and DACBCLK are outputs.

The input multiplexor to the ADC is configured to allow large signal levels to be input to the ADC, using external resistors to reduce the amplitude of larger signals to within the normal operating range of the ADC. The ADC has an analogue input PGA and a digital gain control, accessed by one register write. The input PGA allows input signals to be gained up to +24dB and attenuated down to -21dB in 0.5dB steps. The digital gain control allows attenuation from -21.5dB to -103dB in 0.5dB steps. This allows the user maximum flexibility in the use of the ADC.

The DAC has its own digital volume control, which is adjustable between 0dB and -127.5dB in 0.5dB steps. There is also an analogue volume control on the headphone outputs, which is adjustable between +6dB and -73dB in 1dB steps. The analogue and digital volume controls may be operated independently. In addition a zero cross detect circuit is provided for both analogue and digital volume controls. When analogue volume zero-cross detection is enabled the attenuation values are only updated when the input signal to the gain stage is close to the analogue ground level. The digital volume control detects a transition through the zero point before updating the volume. This minimises audible clicks and 'zipper' noise as the gain values change.

The DAC output incorporates an input selector and mixer allowing a signal to be either switched into the signal path in place of the DAC signal or mixed with the DAC signal before the volume control. Use of external resistors allows larger input levels to be accepted by the device, giving maximum user flexibility.

Internal functionality is controlled by CE, CL, DI and MODE input pins. The MODE pin determines which of the two control interface modes is selected.

Operation using system clock of 128fs, 192fs, 256fs, 384fs, 512fs or 768fs is provided. In Slave mode selection between clock rates is automatically controlled. In master mode the master clock to sample rate ratio is set by control bits ADCRATE and DACRATE. ADC and DAC may run at different rates and have their own bit clocks and master clocks.

The audio data interface supports right, left and I²S interface formats along with a highly flexible DSP serial port interface.

AUDIO DATA SAMPLING RATES

In a typical digital audio system there is only one central clock source producing a reference clock to which all audio data processing is synchronised. This clock is often referred to as the audio system's Master Clock. The WM8776 uses separate master clocks for the ADC and DAC. The external master system clocks can be applied directly through the ADCMCLK and DACMCLK input pins with no software configuration necessary. In a system where there are a number of possible sources for the reference clock it is recommended that the clock source with the lowest jitter be used to optimise the performance of the ADC and DAC.

The master clock for WM8776 supports DAC and ADC audio sampling rates from 256fs to 768fs, where fs is the audio sampling frequency (DACLRC or ADCLRC) typically 32kHz, 44.1kHz, 48kHz or 96kHz (the DAC also supports operation at 128fs and 192fs and 192kHz sample rate). The master clock is used to operate the digital filters and the noise shaping circuits.

In Slave mode the WM8776 has a master detection circuit that automatically determines the relationship between the master clock frequency and the sampling rate (to within +/- 32 system clocks). If there is a greater than 32 clocks error the interface is disabled and maintains the output level at the last sample. The master clock should be synchronised with ADCLRC/DACLRC for optimal performance, although the WM8776 is tolerant of phase variations or jitter on this clock. Table 6 shows the typical master clock frequency inputs for the WM8776.

The signal processing for the WM8776 typically operates at an oversampling rate of 128fs for both ADC and DAC. The exception to this for the DAC is for operation with a 128/192fs system clock, e.g. for 192kHz operation where the oversampling rate is 64fs. For ADC operation at 96kHz it is recommended that the user set the ADCOSR bit. This changes the ADC signal processing oversample rate to 64fs.

| SAMPLING RATE (DACLRC/ ADCLRC) | System Clock Frequency (MHz) | | | | | |
|--------------------------------------|------------------------------|--------|-------------|-------------|-------------|-------------|
| | 128fs | 192fs | 256fs | 384fs | 512fs | 768fs |
| | DAC ONLY | | | | | |
| 32kHz | 4.096 | 6.144 | 8.192 | 12.288 | 16.384 | 24.576 |
| 44.1kHz | 5.6448 | 8.467 | 11.2896 | 16.9340 | 22.5792 | 33.8688 |
| 48kHz | 6.144 | 9.216 | 12.288 | 18.432 | 24.576 | 36.864 |
| 96kHz | 12.288 | 18.432 | 24.576 | 36.864 | Unavailable | Unavailable |
| 192kHz | 24.576 | 36.864 | Unavailable | Unavailable | Unavailable | Unavailable |

Table 6 System Clock Frequencies Versus Sampling Rate

In Master mode DACBCLK, ADCBCLK, DACLRC and ADCLRC are generated by the WM8776. The frequencies of ADCLRC and DACLRC are set by setting the required ratio of DACMCLK to DACLRC and ADCMCLK to ADCLRC using the DACRATE and ADCRATE control bits (Table 7).

| ADCRATE[2:0]/ DACRATE[2:0] | ADCMCLK/DACMCLK: ADCLRC/DACLRC RATIO |
|-------------------------------|--|
| 000 | 128fs (DAC Only) |
| 001 | 192fs (DAC Only) |
| 010 | 256fs |
| 011 | 384fs |
| 100 | 512fs |
| 101 | 768fs |

Table 7 Master Mode MCLK:ADCLRC/DACLRC Ratio Select

Table 8 shows the settings for ADCRATE and DACRATE for common sample rates and ADCMCLK/DACMCLK frequencies.

| SAMPLING RATE (DACLRC/ ADCLRC) | System Clock Frequency (MHz) | | | | | |
|--------------------------------------|------------------------------|-----------------|-----------------------------|-----------------------------|-----------------------------|-----------------------------|
| | 128fs | 192fs | 256fs | 384fs | 512fs | 768fs |
| | DACRATE =000 | DACRATE =001 | ADCRATE/ DACRATE =010 | ADCRATE/ DACRATE =011 | ADCRATE/ DACRATE =100 | ADCRATE/ DACRATE =101 |
| 32kHz | 4.096 | 6.144 | 8.192 | 12.288 | 16.384 | 24.576 |
| 44.1kHz | 5.6448 | 8.467 | 11.2896 | 16.9340 | 22.5792 | 33.8688 |
| 48kHz | 6.144 | 9.216 | 12.288 | 18.432 | 24.576 | 36.864 |
| 96kHz | 12.288 | 18.432 | 24.576 | 36.864 | Unavailable | Unavailable |
| 192kHz | 24.576 | 36.864 | Unavailable | Unavailable | Unavailable | Unavailable |

Table 8 Master Mode ADC/DACLRC Frequency Selection

ADCBCLK and DACBCLK are also generated by the WM8776. The frequency of ADCBCLK and DACBCLK depends on the mode of operation.

In 128/192fs modes (DACRATE=000 or 001) BCLK = MCLK/2. In 256/384/512fs modes (ADCRATE/DACRATE=010 or 011 or 100) BCLK = MCLK/4. However if DSP mode is selected as the audio interface mode then BCLK=MCLK. Note that DSP mode cannot be used in 128fs mode for word lengths greater than 16 bits or in 192fs mode for word lengths greater than 24 bits.

ZERO DETECT

The WM8776 has a zero detect circuit for each DAC channel, which detects when 1024 consecutive zero samples have been input. The two zero flag outputs (ZFLAGL and ZFLAGR) may be programmed to output the zero detect signals (see Table 9) that may then be used to control external muting circuits. A '1' on ZFLAGL or ZFLAGR indicates a zero detect. The zero detect may also be used to automatically enable the PGA mute by setting IZD. The zero flag output may be disabled by setting DZFM to 00. The zero flag signal for each DAC channel will only be enabled if it is enabled as an input to the output summing stage.

| DZFM[1:0] | ZFLAGL | ZFLAGR |
|-----------|----------------------|---------------------|
| 00 | Zero flag disabled | Zero flag disabled |
| 01 | Left channel zero | Right channel zero |
| 10 | Both channel zero | Both channel zero |
| 11 | Either channels zero | Either channel zero |

Table 9 Zero Flag Output Select

POWERDOWN MODES

The WM8776 has powerdown control bits allowing specific parts of the WM8776 to be powered off when not being used. The 5-channel input source selector and input buffer may be powered down using control bit AINPD. When AINPD is set all inputs to the source selector (AIN1/R to AIN5/L/R) are switched to a buffered VMIDADC. Control bit ADCPD powers off the ADC and also the ADC input PGAs. The stereo DAC has a separate powerdown control bit, DACPD allowing the DAC and analogue output mixer to be powered off when not in use. This also switches the analogue outputs VOUTL/R to VMIDDAC to maintain a dc level on the output.

Setting AINPD, ADCPD and DACPD will powerdown everything except the references VMIDADC, ADCREF and VMIDDAC. These may be powered down by setting PDWN. Setting PDWN will override all other powerdown control bits. It is recommended that AINPD, HPPD, ADCPD and DACPD are set before setting PDWN. The default is for all blocks to be enabled other than HPPD.

DIGITAL AUDIO INTERFACE

MASTER AND SLAVE MODES

The audio interface operates in either Slave or Master mode, selectable using the MS control bit. In both Master and Slave modes DIN is always an input to the WM8776 and DOUT is always an output. The default is Slave mode.

In Slave mode (MS=0) ADCLRC, DACLRC, ADCBCLK and DACBCLK are inputs to the WM8776 (Figure 11). DIN and DACLRC are sampled by the WM8776 on the rising edge of DACBCLK, ADCLRC is sampled on the rising edge of ADCBCLK. ADC data is output on DOUT and changes on the falling edge of ADCBCLK. By setting control bit BCLKINV the polarity of ADCBCLK and DACBCLK may be reversed so that DIN and DACLRC are sampled on the falling edge of DACBCLK, ADCLRC is sampled on the falling edge of ADCBCLK and DOUT changes on the rising edge of ADCBCLK.

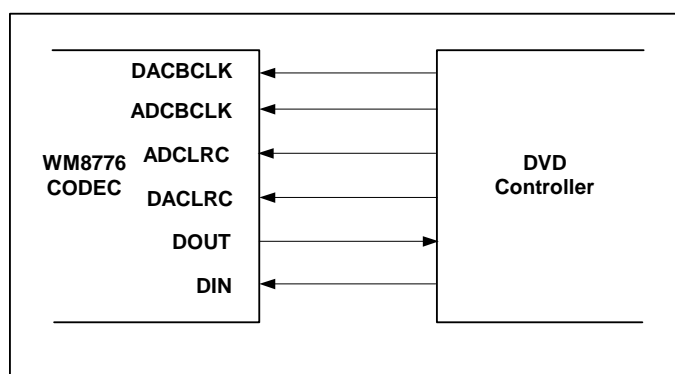

Figure 11 Slave Mode

In Master mode (MS=1) ADCLRC, DACLRC, ADCBCLK and DACBCLK are outputs from the WM8776 (Figure 12). ADCLRC, DACLRC, ADCBCLK and DACBCLK are generated by the WM8776. DIN is sampled by the WM8776 on the rising edge of DACBCLK so the controller must output DAC data that changes on the falling edge of DACBCLK. ADC data is output on DOUT and changes on the falling edge of ADCBCLK. By setting control bit BCLKINV, the polarity of ADCBCLK and DACBCLK may be reversed so that DIN is sampled on the falling edge of DACBCLK and DOUT changes on the rising edge of ADCBCLK.

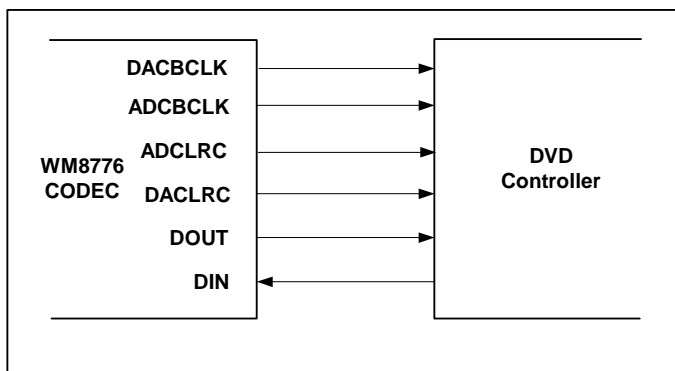

Figure 12 Master Mode

AUDIO INTERFACE FORMATS

Audio data is applied to the internal DAC filters or output from the ADC filters, via the Digital Audio Interface. 5 popular interface formats are supported:

- Left Justified mode
- Right Justified mode
- I²S mode
- DSP mode A
- DSP mode B

All 5 formats send the MSB first and support word lengths of 16, 20, 24 and 32 bits, with the exception of 32 bit right justified mode, which is not supported.

In left justified, right justified and I²S modes, the digital audio interface receives DAC data on the DIN input and outputs ADC data on DOUT. Audio Data for each stereo channel is time multiplexed with ADCLRC/DACLRC indicating whether the left or right channel is present. ADCLRC/DACLRC is also used as a timing reference to indicate the beginning or end of the data words.

In left justified, right justified and I²S modes; the minimum number of BCLKs per DACLRC/ADCLRC period is 2 times the selected word length. ADCLRC/DACLRC must be high for a minimum of word length BCLKs and low for a minimum of word length BCLKs. Any mark to space ratio on ADCLRC/DACLRC is acceptable provided the above requirements are met.

In DSP modes A or B, DACLRC is used as a frame sync signal to identify the MSB of the first word. The minimum number of DACBCLKs per DACLRC period is 2 times the selected word length. Any mark to space ratio is acceptable on DACLRC provided the rising edge is correctly positioned. The ADC data may also be output in DSP modes A or B, with ADCLRC used as a frame sync to identify the MSB of the first word. The minimum number of ADCBCLKs per ADCLRC period is 2 times the selected word length.

LEFT JUSTIFIED MODE

In left justified mode, the MSB of DIN is sampled by the WM8776 on the first rising edge of DACBCLK following a DACLRC transition. The MSB of the ADC data is output on DOUT and changes on the same falling edge of ADCBCLK as ADCLRC and may be sampled on the rising edge of ADCBCLK. ADCLRC and DACLRC are high during the left samples and low during the right samples (Figure 13).

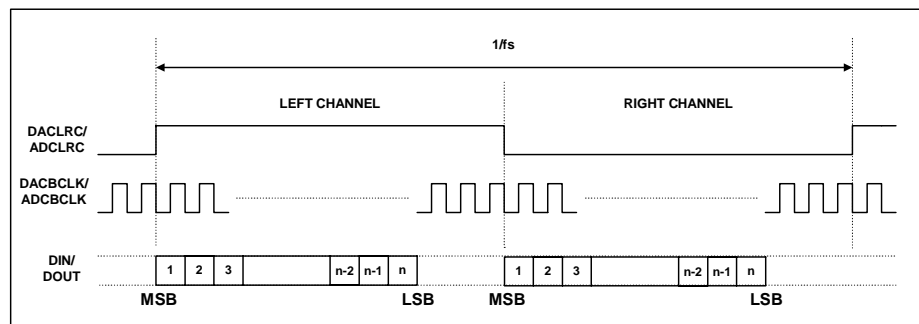

Figure 13 Left Justified Mode Timing Diagram

RIGHT JUSTIFIED MODE

In right justified mode, the LSB of DIN is sampled by the WM8776 on the rising edge of DACBCLK preceding a DACLRC transition. The LSB of the ADC data is output on DOUT and changes on the falling edge of ADCBCLK preceding a ADCLRC transition and may be sampled on the rising edge of ADCBCLK. ADCLRC and DACLRC are high during the left samples and low during the right samples (Figure 14).

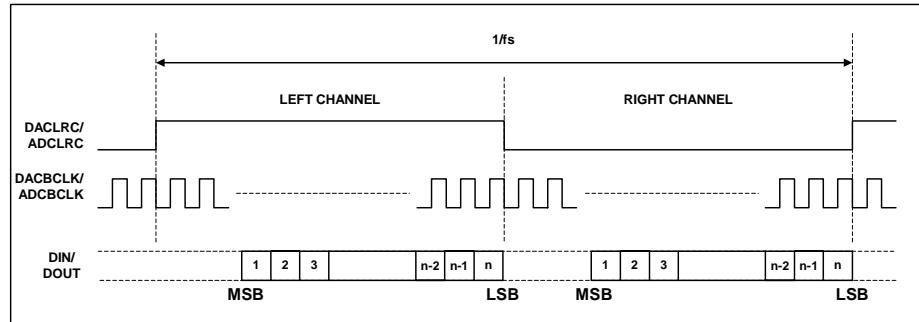

Figure 14 Right Justified Mode Timing Diagram

I²S MODE

In I²S mode, the MSB of DIN is sampled by the WM8776 on the second rising edge of DACBCLK following a DACLRC transition. The MSB of the ADC data is output on DOUT and changes on the first falling edge of ADCBCLK following an ADCLRC transition and may be sampled on the rising edge of ADCBCLK. ADCLRC and DACLRC are low during the left samples and high during the right samples.

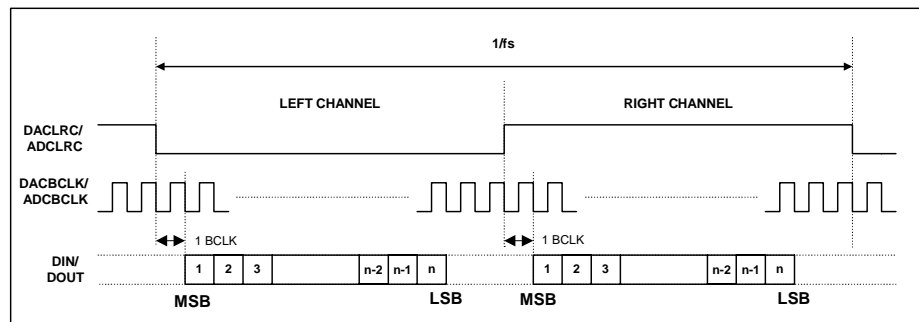

Figure 15 I²S Mode Timing Diagram

DSP MODES

In DSP/PCM mode, the left channel MSB is available on either the 1st (mode B) or 2nd (mode A) rising edge of BCLK (selectable by LRP) following a rising edge of LRC. Right channel data immediately follows left channel data. Depending on word length, BCLK frequency and sample rate, there may be unused BCLK cycles between the LSB of the right channel data and the next sample.

In device master mode, the LRC output will resemble the frame pulse shown in Figure 16 and Figure 17. In device slave mode, Figure 18 and Figure 19, it is possible to use any length of frame pulse less than 1/fs, providing the falling edge of the frame pulse occurs greater than one BCLK period before the rising edge of the next frame pulse.

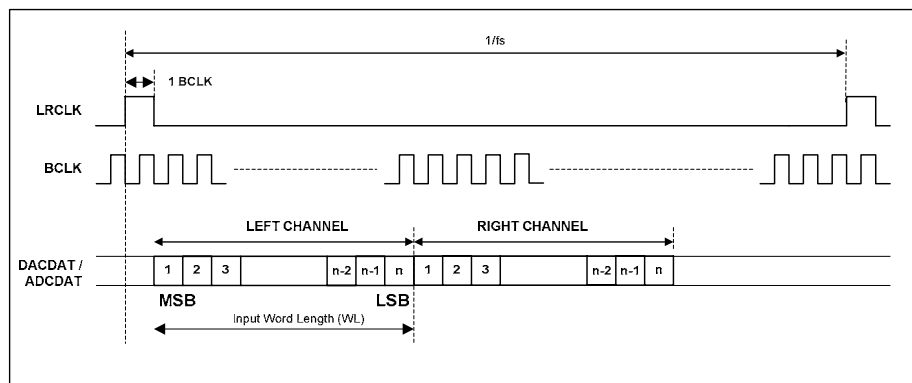

Figure 16 DSP/PCM Mode Audio Interface (mode A, LRP=0, Master)

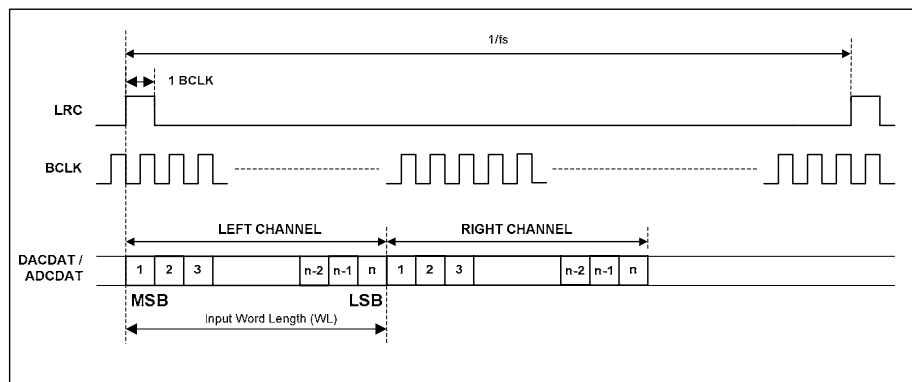

Figure 17 DSP/PCM Mode Audio Interface (mode B, LRP=1, Master)

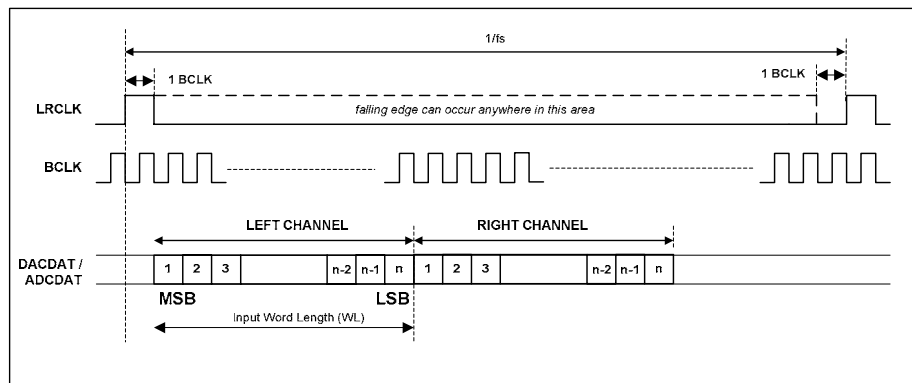

Figure 18 DSP/PCM Mode Audio Interface (mode A, LRP=0, Slave)

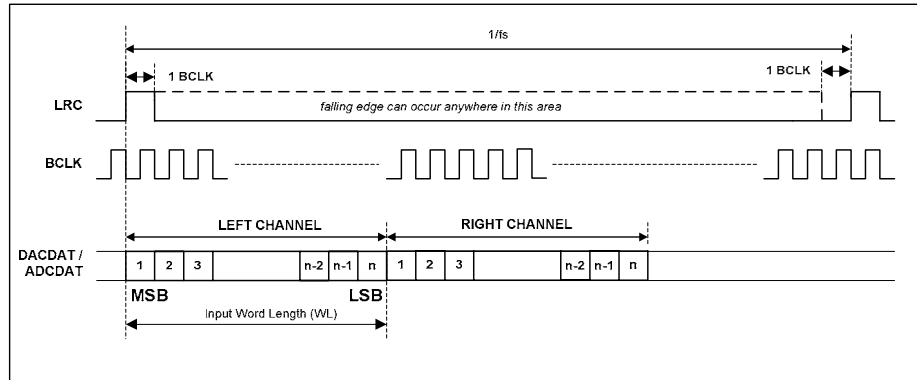

Figure 19 DSP/PCM Mode Audio Interface (mode B, LRP=0, Slave)

CONTROL INTERFACE OPERATION

The WM8776 is controlled by writing to registers through a serial control interface. A control word consists of 16 bits. The first 7 bits (B15 to B9) are address bits that select which control register is accessed. The remaining 9 bits (B8 to B0) are data bits, corresponding to the 9 bits in each control register. The control interface can operate as either a 3-wire or 2-wire MPU interface. The MODE pin selects the interface format, as shown in Table 10. .

| MODE | Control Mode |
|------|------------------|
| 0 | 2 wire interface |
| 1 | 3 wire interface |

Table 10 Control Interface Selection via MODE Pin

3-WIRE (SPI COMPATIBLE) SERIAL CONTROL MODE

In 3-wire mode, every rising edge of CL clocks in one data bit from the DI pin. A rising edge on CE latches in a complete control word consisting of the last 16 bits. The 3-wire interface protocol is shown in Figure 20.

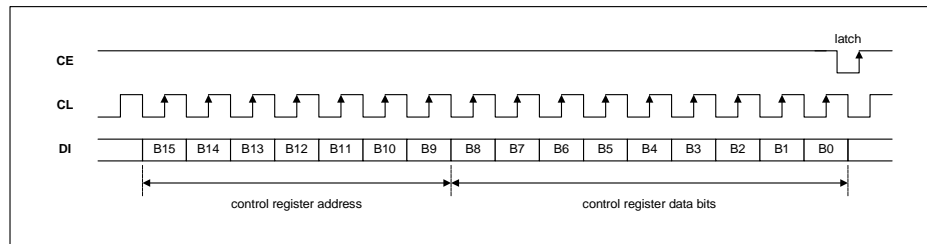

Figure 20 3-wire SPI Compatible Interface

1. B[15:9] are Control Address Bits
2. B[8:0] are Control Data Bits
3. CE is edge sensitive – the data is latched on the rising edge of CE.

2-WIRE SERIAL CONTROL MODE

The WM8776 supports software control via a 2-wire serial bus. Many devices can be controlled by the same bus, and each device has a unique 7-bit address (this is not the same as the 7-bit address of each register in the WM8776).

The WM8776 operates as a slave device only. The controller indicates the start of data transfer with a high to low transition on DI while CL remains high. This indicates that a device address and data will follow. All devices on the 2-wire bus respond to the start condition and shift in the next eight bits on DI (7-bit address + Read/Write bit, MSB first). If the device address received matches the address of the WM8776 and the R/W bit is '0', indicating a write, then the WM8776 responds by pulling DI low on the next clock pulse (ACK). If the address is not recognised or the R/W bit is '1', the WM8776 returns to the idle condition and wait for a new start condition and valid address.

Once the WM8776 has acknowledged a correct address, the controller sends the first byte of control data (B15 to B8, i.e. the WM8776 register address plus the first bit of register data). The WM8776 then acknowledges the first data byte by pulling DI low for one clock pulse. The controller then sends the second byte of control data (B7 to B0, i.e. the remaining 8 bits of register data), and the WM8776 acknowledges again by pulling DI low.

The transfer of data is complete when there is a low to high transition on DI while CL is high. After receiving a complete address and data sequence the WM8776 returns to the idle state and waits for another start condition. If a start or stop condition is detected out of sequence at any point during data transfer (i.e. DI changes while CL is high), the device jumps to the idle condition.

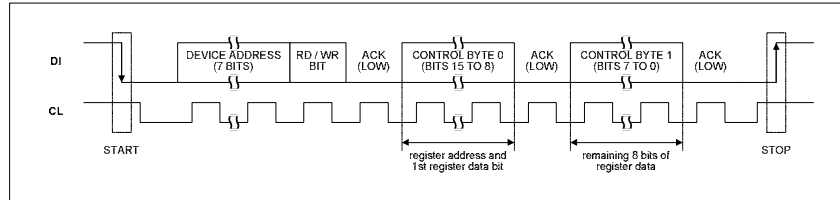

Figure 21 2-wire Serial Interface

1. B[15:9] are Control Address Bits
2. B[8:0] are Control Data Bits

The WM8776 has two possible device addresses, which can be selected using the CE pin.

| CE STATE | DEVICE ADDRESS |
|----------|-------------------|
| Low | 0011010 (0 x 34h) |
| High | 0011011 (0 x 36h) |

Table 11 2-Wire MPU Interface Address Selection

CONTROL INTERFACE REGISTERS

DIGITAL AUDIO INTERFACE CONTROL REGISTER

Interface format is selected via the FMT[1:0] register bits:

| REGISTER ADDRESS | BIT | LABEL | DEFAULT | DESCRIPTION |
|---|-----|-----------------|---------|---|
| R10 (0Ah) 0001010 DAC Interface Control | 1:0 | DACFMT [1:0] | 10 | Interface format Select 00 : right justified mode 01: left justified mode |
| R11 (0Bh) 0001011 ADC Interface Control | 1:0 | ADCFMT [1:0] | 10 | 10: I ² S mode 11: DSP (early or late) mode |

In left justified, right justified or I²S modes, the LRP register bit controls the polarity of ADCLRC/DACLRC. If this bit is set high, the expected polarity of ADCLRC/DACLRC will be the opposite of that shown Figure 13, Figure 14, etc. Note that if this feature is used as a means of swapping the left and right channels, a 1 sample phase difference will be introduced. In DSP modes, the LRP register bit is used to select between early and late modes.

| REGISTER ADDRESS | BIT | LABEL | DEFAULT | DESCRIPTION |
|---|-----|--------|---------|--|
| R10 (0Ah) 0001010 DAC Interface Control | 2 | DACLRP | 0 | In left/right/ I ² S modes: ADCLRC/DACLRC Polarity (normal) 0 : normal ADCLRC/DACLRC polarity 1: inverted ADCLRC/DACLRC polarity |
| R11 (0Bh) 0001011 ADC Interface Control | 2 | ADCLRP | 0 | In DSP mode: 0 : Early DSP mode 1: Late DSP mode |

By default, ADCLRC, DACLRC and DIN are sampled on the rising edge of ADCBCLK and DACBCLK and should ideally change on the falling edge. Data sources that change ADCLRC/DACLRC and DIN on the rising edge of ADCBCLK/DACBCLK can be supported by setting the BCP register bit. Setting BCP to 1 inverts the polarity of BCLK to the inverse of that shown in Figure 13, Figure 14, etc.

| REGISTER ADDRESS | BIT | LABEL | DEFAULT | DESCRIPTION |
|---|-----|--------|---------|--|
| R10 (0Ah) 0001010 DAC Interface Control | 3 | DACBCP | 0 | BCLK Polarity (DSP modes) 0 : normal BCLK polarity 1: inverted BCLK polarity |
| R11 (0Bh) 0001011 ADC Interface Control | 3 | ADCBCP | 0 | |

The WL[1:0] bits are used to control the input word length.

| REGISTER ADDRESS | BIT | LABEL | DEFAULT | DESCRIPTION |
|---|-----|----------------|---------|--|
| R10 (0Ah) 0001010 DAC Interface Control | 5:4 | DACWL [1:0] | 10 | Word Length 00 : 16 bit data 01: 20 bit data |
| R11 (0Bh) 0001011 ADC Interface Control | 5:4 | ADCWL [1:0] | 10 | 10: 24 bit data 11: 32 bit data |

Note: If 32-bit mode is selected in right justified mode, the WM8776 defaults to 24 bits.

In all modes, the data is signed 2's complement. The digital filters always input 24-bit data. If the DAC is programmed to receive 16 or 20 bit data, the WM8776 pads the unused LSBs with zeros. If the DAC is programmed into 32 bit mode, the 8 LSBs are ignored.

Note: In 24 bit I²S mode, any width of 24 bits or less is supported provided that ADCLRC/DACLRC is high for a minimum of 24 BCLKs and low for a minimum of 24 BCLKs.

When operating the ADC digital interface in slave mode, to optimise the performance of the ADC it is recommended that the ADCMCLK and ADCBCLK input signals do not have coinciding rising edges. The ADCMCLK bit provides the option to internally invert the ADCMCLK input signal when the input signals have coinciding rising edges.

| REGISTER ADDRESS | BIT | LABEL | DEFAULT | DESCRIPTION |
|---|-----|---------|---------|---|
| R11 (0Bh) 0001011 Interface Control | 6 | ADCMCLK | 0 | ADCMCLK Polarity 0 : non-inverted 1: inverted |

A number of options are available to control how data from the Digital Audio Interface is applied to the DAC.

MASTER MODES

Control bit ADCMS selects between audio interface Master and Slave Modes for ADC. In ADC Master mode ADCLRC and ADCBCLK are outputs and are generated by the WM8776. In Slave mode ADCLRC and ADCBCLK are inputs to WM8776.

| REGISTER ADDRESS | BIT | LABEL | DEFAULT | DESCRIPTION |
|---|-----|-------|---------|---|
| R12 (0Ch) 0001100 Interface Control | 9 | ADCMS | 0 | Audio Interface Master/Slave Mode select for ADC: 0 : Slave Mode 1: Master Mode |

Control bit DACMS selects between audio interface Master and Slave Modes for the DAC. In DAC Master mode DACLRC and DACBCLK are outputs and are generated by the WM8776. In Slave mode DACLRC and DACBCLK are inputs to WM8776.

| REGISTER ADDRESS | BIT | LABEL | DEFAULT | DESCRIPTION |
|---|-----|-------|---------|---|
| R12 (0Ch) 0001100 Interface Control | 8 | DACMS | 0 | Audio Interface Master/Slave Mode select for DAC: 0 : Slave Mode 1: Master Mode |

MASTER MODE ADCLRC/DACLRC FREQUENCY SELECT

In ADC Master mode the WM8776 generates ADCLRC and ADCBCLK, in DAC master mode the WM8776 generates DACLRC and DACBCLK. These clocks are derived from the master clock (ADCMCLK or DACMCLK). The ratios of ADCMCLK to ADCLRC and DACMCLK to DACLRC are set by ADCRATE and DACRATE respectively.

| REGISTER ADDRESS | BIT | LABEL | DEFAULT | DESCRIPTION |
|---|-----|--------------|---------|---|
| R12 (0Ch) 0001100 ADCLRC and DACLRC frequency select | 2:0 | ADCRATE[2:0] | 010 | Master Mode MCLK:ADCLRC ratio select: 010: 256fs 011: 384fs 100: 512fs 101: 768fs |
| | 6:4 | DACRATE[2:0] | 010 | Master Mode MCLK:DACLRC ratio select: 000: 128fs 001: 192fs 010: 256fs 011: 384fs 100: 512fs 101: 768fs |

ADC OVERSAMPLING RATE SELECT

For ADC operation at 96kHz it is recommended that the user set the ADCOSR bit. This changes the ADC signal processing oversample rate to 64fs.

| REGISTER ADDRESS | BIT | LABEL | DEFAULT | DESCRIPTION |
|---|-----|--------|---------|---|
| R12 (0Ch) 0001100 ADC Oversampling Rate | 3 | ADCOSR | 0 | ADC oversampling rate select 0: 128x oversampling 1: 64x oversampling |

MUTE MODES

Setting MUTE for the DAC will apply a 'soft' mute to the input of the digital filters of the channel muted.

| REGISTER ADDRESS | BIT | LABEL | DEFAULT | DESCRIPTION |
|---------------------------------|-----|-------|---------|--|
| R8 (08h) 0001000 DAC Mute | 0 | DMUTE | 0 | DAC Soft Mute select 0 : Normal Operation 1: Soft mute enabled |

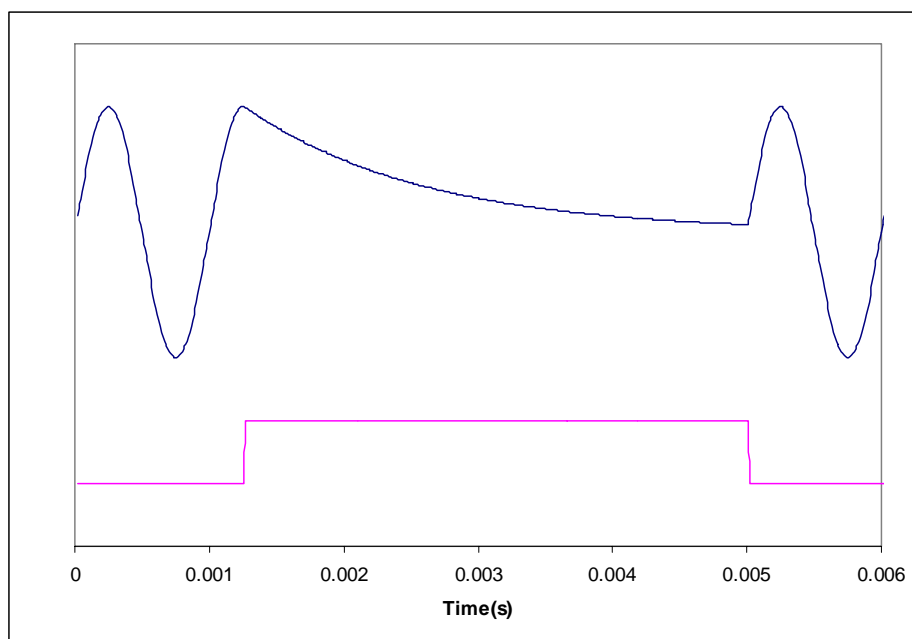

Figure 22 Application and Release of Soft Mute

Figure 22 shows the application and release of DMUTE whilst a full amplitude sinusoid is being played at 48kHz sampling rate. When DMUTE (lower trace) is asserted, the output (upper trace) begins to decay exponentially from the DC level of the last input sample. The output will decay towards V_{MID} with a time constant of approximately 64 input samples. If DMUTE is applied to both channels for 1024 or more input samples the DAC will be muted if IZD is set. When DMUTE is de-asserted, the output will restart immediately from the current input sample.

Note that all other means of muting the DAC: setting the PL[3:0] bits to 0, setting the PDWN bit or setting attenuation to 0 will cause much more abrupt muting of the output.

ADC MUTE

Each ADC channel also has an individual mute control bit, which mutes the input to the ADC PGA. By setting the LRBOOTH bit (reg22, bit 8) both channels can be muted simultaneously.

| REGISTER ADDRESS | BIT | LABEL | DEFAULT | DESCRIPTION |
|--|-----|--------|---------|--|
| R21 (15h) 0010101 ADC Mute Left | 7 | MUTELA | 0 | ADC Mute select 0 : Normal Operation 1: mute ADC left |
| R21 (15h) 0001111 ADC Mute Right | 6 | MUTERA | 0 | ADC Mute select 0 : Normal Operation 1: mute ADC right |

DE-EMPHASIS MODE

The De-emphasis filter for the DAC is enabled under the control of DEEMP.

| REGISTER ADDRESS | BIT | LABEL | DEFAULT | DESCRIPTION |
|---|-----|--------|---------|--|
| R9 (09h) 0001001 DAC De-emphasis Control | 0 | DEEMPH | 0 | De-emphasis mode select: 0 : Normal Mode 1: De-emphasis Mode |

Refer to Figure 35, Figure 36, Figure 37, Figure 38, Figure 39 and Figure 40 for details of the De-Emphasis modes at different sample rates.

POWERDOWN MODE AND ADC/DAC DISABLE

Setting the PDWN register bit immediately powers down the WM8776, including the references, overriding all other powerdown control bits. All trace of the previous input samples is removed, but all control register settings are preserved. When PDWN is cleared, the digital filters will be re-initialised. It is recommended that the 5-channel input mux and buffer, ADC and DAC are powered down before setting PDWN.

| REGISTER ADDRESS | BIT | LABEL | DEFAULT | DESCRIPTION |
|---|-----|-------|---------|--|
| R13 (0Dh) 0001101 Powerdown Control | 0 | PDWN | 0 | Power Down Mode Select: 0 : Normal Mode 1: Power Down Mode |

The ADC, DAC and HEADPHONE PGA'S may also be powered down by setting the ADCD and DACD disable bits. Setting ADCD will disable the ADC and select a low power mode. The ADC digital filters will be reset and will reinitialise when ADCD is reset. The DAC has a separate disable DACD. Setting DACD will disable the DAC, mixer and output PGAs. Resetting DACD will reinitialise the digital filters.

| REGISTER ADDRESS | BIT | LABEL | DEFAULT | DESCRIPTION |
|---|-----|-------|---------|---|
| R13 (0Dh) 0001101 Powerdown Control | 1 | ADCPD | 0 | ADC Powerdown: 0 : Normal Mode 1: Power Down Mode |
| | 2 | DACPD | 0 | DAC Powerdown: 0 : Normal Mode 1: Power Down Mode |
| | 3 | HPPD | 1 | Headphone output/PGA Power down : 0 : HP out enabled 1 : HP out disabled |

The analogue audio inputs and outputs can also be individually powered down by setting the relevant bits in the powerdown register.

| REGISTER ADDRESS | BIT | LABEL | DEFAULT | DESCRIPTION |
|---|-----|-------|---------|--|
| R13 (0Dh) 0001101 Powerdown Control | 6 | AINPD | 0 | Analogue input PGA disable: 0 : Normal Mode 1: Power Down Mode |

DIGITAL ATTENUATOR CONTROL MODE

Setting the ATC register bit causes the left channel attenuation settings to be applied to both left and right channel DACs from the next audio input sample. No update to the attenuation registers is required for ATC to take effect.

| REGISTER ADDRESS | BIT | LABEL | DEFAULT | DESCRIPTION |
|--|-----|-------|---------|--|
| R7 (07h) 0000111 DAC Channel Control | 1 | ATC | 0 | Attenuator Control Mode: 0 : Right channel use Right attenuation 1: Right Channel use Left Attenuation |

INFINITE ZERO DETECT ENABLE

Setting the IZD register bit will enable the internal infinite zero detect function:

| REGISTER ADDRESS | BIT | LABEL | DEFAULT | DESCRIPTION |
|--|-----|-------|---------|---|
| R7 (07h) 0000111 DAC Channel Control | 2 | IZD | 0 | Infinite zero Mute Enable 0 : disable infinite zero mute 1: enable infinite zero Mute |

With IZD enabled, applying 1024 consecutive zero input samples to the DAC will cause both DAC outputs to be muted. Mute will be removed as soon as any channel receives a non-zero input.

DAC OUTPUT CONTROL

The DAC output control word determines how the left and right inputs to the audio Interface are applied to the left and right DACs:

| REGISTER ADDRESS | BIT | LABEL | DEFAULT | DESCRIPTION | | |
|------------------------------------|---------|---------|---------|-------------|-------------|--------------|
| | | | | PL[3:0] | Left Output | Right Output |
| R7 (07h) 0000111 DAC Control | 7:4 | PL[3:0] | 1001 | PL[3:0] | Left Output | Right Output |
| | | | | 0000 | Mute | Mute |
| | | | | 0001 | Left | Mute |
| | | | | 0010 | Right | Mute |
| | | | | 0011 | (L+R)/2 | Mute |
| | | | | 0100 | Mute | Left |
| | | | | 0101 | Left | Left |
| | | | | 0110 | Right | Left |
| | | | | 0111 | (L+R)/2 | Left |
| | | | | 1000 | Mute | Right |
| | | | | 1001 | Left | Right |
| | | | | 1010 | Right | Right |
| | | | | 1011 | (L+R)/2 | Right |
| | | | | 1100 | Mute | (L+R)/2 |
| | | | | 1101 | Left | (L+R)/2 |
| | | | | 1110 | Right | (L+R)/2 |
| 1111 | (L+R)/2 | (L+R)/2 | | | | |

ANALOGUE OUTPUT VOLUME CONTROLS

There are analogue volume controls for the headphone outputs which may be adjusted independently using separate volume control registers.

| REGISTER ADDRESS | BIT | LABEL | DEFAULT | DESCRIPTION |
|--|-----|---------------|---------------|--|
| R0 (00h) 0000000 Analogue Attenuation Headphone Output Left | 6:0 | HPLA[6:0] | 1111001 (0dB) | Attenuation data for Headphone Left channel in 1dB steps. See Table 13 |
| | 7 | HPLZCEN | 0 | Headphone left zero cross detect enable 0: zero cross disabled 1: zero cross enabled |
| | 8 | UPDATE | Not latched | Controls simultaneous update of Headphone Attenuation Latches 0: Store HPLA in intermediate latch (no change to output) 1: Store HPLA and update attenuation on both channels. |
| R1 (01h) 0000001 Analogue Attenuation Headphone Output Right | 6:0 | HPLA[6:0] | 1111001 (0dB) | Attenuation data for Headphone Right channel in 1dB steps. See Table 13 |
| | 7 | HPRZCEN | 0 | Headphone right zero cross detect enable 0: zero cross disabled 1: zero cross enabled |
| | 8 | UPDATE | Not latched | Controls simultaneous update of Headphone Attenuation Latches 0: Store HPRA in intermediate latch (no change to output) 1: Store HPRA and update attenuation on both channels. |
| R2 (02h) 0000010 Headphone Master Analogue Attenuation (both channels) | 6:0 | HPMASTA [6:0] | 1111001 (0dB) | Attenuation data for both Headphone channels in 1dB steps. See Table 13 |
| | 7 | MZCEN | 0 | Master zero cross detect enable 0: zero cross disabled 1: zero cross enabled |
| | 8 | UPDATEA | Not latched | Controls simultaneous update of Attenuation Latches 0: Store gain in intermediate latch (no change to output) 1: Store gain and update attenuation on all channels. |
| R13 (0Dh) 0001101 Power Down | 3 | HPPD | 1 | Headphone output/PGA Power Down 0 : HP out enabled 1 : HP out disabled |

Table 12 Headphone Attenuation Register Map

Each analogue headphone output channel has a PGA which can be used to attenuate the output from that channel. The PGA's can be powered up or down using the HPPD bit. Attenuation is 0dB by default but can be set between +6dB and -73dB in 1dB steps using the two Attenuation control words. The attenuation registers are double latched allowing them to be updated in pairs. Setting the UPDATE bit on an attenuation write to one channel, for example HPOUTL, will cause the pre-latched value in HPOUTR to be applied to the PGA. A master attenuation register is also included, allowing both volume levels to be set to the same value in a single write.

Note: The UPDATE bit is not latched. If UPDATE=0, the Attenuation value will be written to the pre-latch but not applied to the PGA. If UPDATE=1, pre-latched values will be applied from the next input sample. Writing to HPMASTA[6:0] overwrites any values previously sent to HPLA[6:0] and HPRA[6:0].

HEADPHONE OUTPUT PGA ATTENUATION

The analogue output PGAs are controlled by the HPLA and HPRA registers. Register bits MASTA can be used to control attenuation of both channels.

Table 13 shows how the attenuation levels are selected from the 7-bit words.

| HPLA/ HPRA[6:0] | ATTENUATION LEVEL |
|-----------------|-------------------|
| 00(hex) | -∞dB (mute) |
| : | : |
| 2F(hex) | -∞dB (mute) |
| 30(hex) | -73dB |
| : | : |
| 79 (hex) | 0dB (default) |
| : | : |
| 7D(hex) | +4dB |
| 7E(hex) | +5dB |
| 7F(hex) | +6dB |

Table 13 Headphone Volume Control Attenuation Levels

In addition a zero cross detect circuit is provided for the output PGA volume under the control of bit 7 (ZCEN) in the each attenuation register. When ZCEN is set the attenuation values are only updated when the input signal to the gain stage is close to the analogue ground level. This minimises audible clicks and 'zipper' noise as the gain values change. A timeout clock is also provided which will generate an update after a minimum of 131072 master clocks (= ~10.5ms with a master clock of 12.288MHz). The timeout clock may be disabled by setting TOD.

| REGISTER ADDRESS | BIT | LABEL | DEFAULT | DESCRIPTION |
|--|-----|-------|---------|--|
| R7 (07h) 0000111 Timeout Clock Disable | 3 | TOD | 0 | DAC and ADC Analogue Zero cross detect timeout disable 0 : Timeout enabled 1: Timeout disabled |

DAC DIGITAL VOLUME CONTROL

The DAC volume may also be adjusted in the digital domain using independent digital attenuation control registers

| REGISTER ADDRESS | BIT | LABEL | DEFAULT | DESCRIPTION |
|---|-----|-------------|----------------|--|
| R3 (03h) 0000011 Digital Attenuation DACL | 7:0 | LDA[7:0] | 11111111 (0dB) | Digital Attenuation data for Left channel DACL in 0.5dB steps. See Table 14 |
| | 8 | UPDATED | Not latched | Controls simultaneous update of Attenuation Latches 0: Store LDA in intermediate latch (no change to output) 1: Store LDA and update attenuation on both channels |
| R4 (04h) 0000100 Digital Attenuation DACR | 7:0 | RDA[6:0] | 11111111 (0dB) | Digital Attenuation data for Right channel DACR in 0.5dB steps. See Table 14 |
| | 8 | UPDATED | Not latched | Controls simultaneous update of Attenuation Latches 0: Store RDA in intermediate latch (no change to output) 1: Store RDA and update attenuation on both channels. |
| R5 (05h) 0000101 Master Digital Attenuation (both channels) | 7:0 | MASTDA[7:0] | 11111111 (0dB) | Digital Attenuation data for DAC channels in 0.5dB steps. See Table 14 |
| | 8 | UPDATED | Not latched | Controls simultaneous update of Attenuation Latches 0: Store gain in intermediate latch (no change to output) 1: Store gain and update attenuation on channels. |

| L/RDA[7:0] | ATTENUATION LEVEL |
|------------|-------------------|
| 00(hex) | -∞ dB (mute) |
| 01(hex) | -127dB |
| : | : |
| : | : |
| : | : |
| FE(hex) | -0.5dB |
| FF(hex) | 0dB |

Table 14 Digital Volume Control Attenuation Levels

The digital volume control also incorporates a zero cross detect circuit which detects a transition through the zero point before updating the digital volume control with the new volume. This is enabled by control bit DZCEN.

| REGISTER ADDRESS | BIT | LABEL | DEFAULT | DESCRIPTION |
|------------------------------------|-----|-------|---------|--|
| R7 (07h) 0000111 DAC Control | 0 | DZCEN | 0 | DAC Digital Volume Zero Cross Enable: 0: Zero cross detect disabled 1: Zero cross detect enabled |

DAC OUTPUT PHASE

The DAC Phase control word determines whether the output of the DAC is non-inverted or inverted

| REGISTER ADDRESS | BIT | LABEL | DEFAULT | DESCRIPTION | | |
|----------------------------------|-----|---------|---------|-------------|------|------------|
| R6 (06h) 0000110 DAC Phase | 1:0 | PH[1:0] | 00 | Bit | DAC | Phase |
| | | | | 0 | DACL | 1 = invert |
| | | | | 1 | DACR | 1 = invert |

ADC GAIN CONTROL

The ADC has an analogue input PGA and digital gain control for each stereo channel. Both the analogue and digital gains are adjusted by the same register, LAG for the left and RAG for the right. The analogue PGA has a range of +24dB to -21dB in 0.5dB steps. The digital gain control allows further attenuation (after the ADC) from -21.5dB to -103dB in 0.5dB steps. Table 15 shows how the register maps the analogue and digital gains.

| LAG/RAG[7:0] | ATTENUATION LEVEL (AT OUTPUT) | ANALOGUE PGA | DIGITAL ATTENUATION |
|--------------|-------------------------------|--------------|---------------------|
| 00(hex) | -∞ dB (mute) | -21dB | Digital mute |
| 01(hex) | -103dB | -21dB | -82dB |
| : | : | : | : |
| A4(hex) | -21.5dB | -21dB | -0.5dB |
| A5(hex) | -21dB | -21dB | 0dB |
| : | : | : | : |
| CF(hex) | 0dB | 0dB | 0dB |
| : | : | : | : |
| FE(hex) | +23.5dB | +23.5dB | 0dB |
| FF(hex) | +24dB | +24dB | 0dB |

Table 15 Analogue and Digital Gain Mapping for ADC

In addition, a zero cross detect circuit is provided for the input PGA, controlled by bit 8 in each attenuation register. This minimises audible clicks and 'zipper' noise by updating the gain when the signal crosses the zero level.

In addition a zero cross detect circuit is provided for the output PGA volume under the control of bit 7 (ZCEN) in the each attenuation register. When ZCEN is set the attenuation values are only updated when the input signal to the gain stage is close to the analogue ground level. This minimises audible clicks and 'zipper' noise as the gain values change. A timeout clock is also provided which will generate an update after a minimum of 131072 master clocks (= ~10.5ms with a master clock of 12.288MHz). The timeout clock may be disabled by setting TOD.

Left and right inputs may also be independently muted. The LRBOTH control bit allows the user to write the same attenuation value to both left and right volume control registers, saving on software writes. The ADC volume and mute also applies to the bypass signal path.

| REGISTER ADDRESS | BIT | LABEL | DEFAULT | DESCRIPTION |
|---|-----|----------|-------------------|---|
| R14 (0Eh) 0001110 Attenuation ADCL | 7:0 | LAG[7:0] | 11001111 (0dB) | Attenuation data for Left channel ADC gain in 0.5dB steps. See Table 15. |
| | 8 | ZCLA | 0 | Left channel ADC zero cross enable: 0: Zero cross disabled 1: Zero cross enabled |
| R15 (0Fh) 0001111 Attenuation ADCR | 7:0 | RAG[7:0] | 11001111 (0dB) | Attenuation data for right channel ADC gain in 0.5dB steps. See Table 15. |
| | 8 | ZCRA | 0 | Right channel ADC zero cross enable: 0: Zero cross disabled 1: Zero cross enabled |
| R21 (15h) 0010101 ADC Input Mux | 8 | LRBOTH | 0 | Right channel input PGA controlled by left channel register 0 : Right channel uses RAG. 1 : Right channel uses LAG. |
| R21 (15h) 0010101 ADC Input Mux | 7 | MUTELA | 0 | Mute for left channel ADC 0: Mute Off 1: Mute on |
| | 6 | MUTERA | 0 | Mute for right channel ADC 0: Mute Off 1: Mute on |

ADC HIGHPASS FILTER DISABLE

The ADC digital filters contain a digital high pass filter. This defaults to enabled and can be disabled using software control bit ADCHPD.

| REGISTER ADDRESS | BIT | LABEL | DEFAULT | DESCRIPTION |
|-------------------------------------|-----|--------|---------|--|
| R11 (0Bh) 0001011 ADC Control | 8 | ADCHPD | 0 | ADC High pass filter disable: 0: High pass filter enabled 1: High pass filter disabled |

LIMITER / AUTOMATIC LEVEL CONTROL (ALC)

The WM8776 has an automatic pga gain control circuit, which can function as a peak limiter or as an automatic level control (ALC). In peak limiter mode, a digital peak detector detects when the input signal goes above a predefined level and will ramp the pga gain down to prevent the signal becoming too large for the input range of the ADC. When the signal returns to a level below the threshold, the pga gain is slowly returned to its starting level. The peak limiter cannot increase the pga gain above its static level.

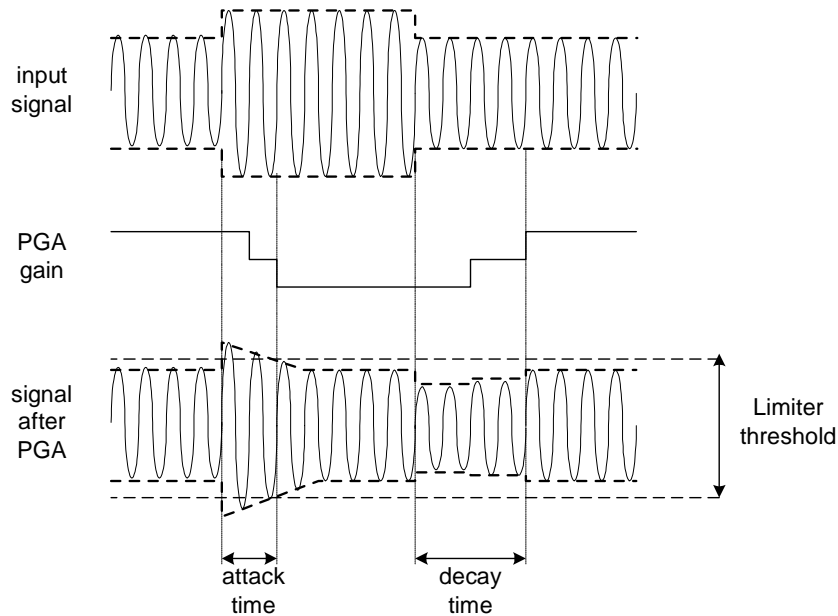

Figure 23 Limiter Operation

In ALC mode, the circuit aims to keep a constant recording volume irrespective of the input signal level. This is achieved by continuously adjusting the PGA gain so that the signal level at the ADC input remains constant. A digital peak detector monitors the ADC output and changes the PGA gain if necessary.

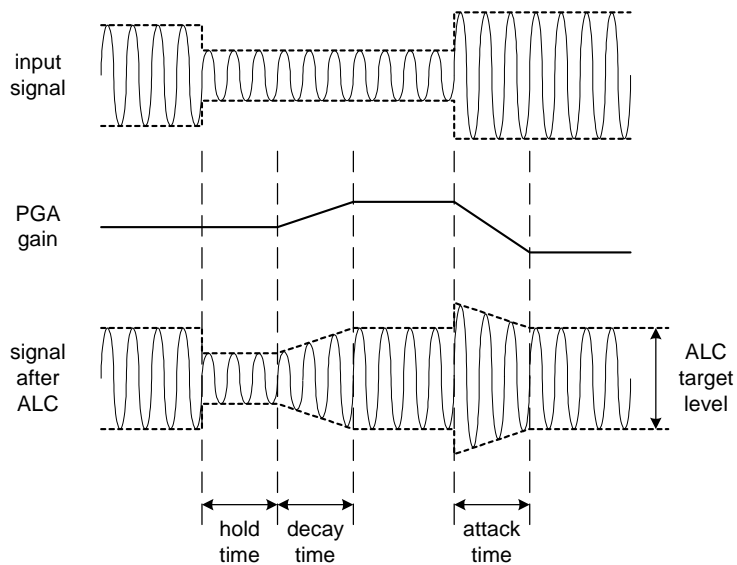

Figure 24 ALC Operation

The gain control circuit is enabled by setting the LCEN control bit. The user can select between Limiter mode and three different ALC modes using the LCSEL control bits.

| REGISTER ADDRESS | BIT | LABEL | DEFAULT | DESCRIPTION |
|---------------------------------------|-----|-------|---------|--|
| R17 (11h) 0010001 ALC Control 2 | 8 | LCEN | 0 | Enable the PGA gain control circuit. 0 = Disabled 1 = Enabled |
| R16 (10h) 0010000 ALC Control 1 | 8:7 | LCSEL | 00 | LC function select 00 = Limiter 01 = ALC Right channel only 10 = ALC Left channel only 11 = ALC Stereo |

The limiter function only operates in stereo, which means that the peak detector takes the maximum of left and right channel peak values, and any new gain setting is applied to both left and right PGAs, so that the stereo image is preserved. However, the ALC function can also be enabled on one channel only. In this case, only one PGA is controlled by the ALC mechanism, while the other channel runs independently with its PGA gain set through the control register.

When enabled, the threshold for the limiter or target level for the ALC is programmed using the LCT control bits. This allows the threshold/target level to be programmed between -1dB and -16dB in 1dB steps.

| REGISTER ADDRESS | BIT | LABEL | DEFAULT | DESCRIPTION |
|---------------------------------------|-----|----------|----------------|--|
| R16 (10h) 0010000 ALC Control 1 | 3:0 | LCT[3:0] | 1011 (-5dB) | Limiter Threshold/ALC target level in 1dB steps. 0000: -16dB FS 0001: -15dB FS ... 1101: -3dB FS 1110: -2dB FS 1111: -1dB FS |

ATTACK AND DECAY TIMES

The limiter and ALC have different attack and decay times which determine their operation. However, the attack and decay times are defined slightly differently for the limiter and for the ALC. DCY and ATK control the decay and attack times, respectively.

Decay time (Gain Ramp-Up). When in ALC mode, this is defined as the time that it takes for the PGA gain to ramp up across 90% of its range (e.g. from -21dB up to +20 dB). When in limiter mode, it is defined as the time it takes for the gain to ramp up by 6dB.

The decay time can be programmed in power-of-two (2^n) steps. For the ALC this gives times from 33.6ms, 67.2ms, 134.4ms etc. to 34.41s. For the limiter this gives times from 1.2ms, 2.4ms etc., up to 1.2288s.

Attack time (Gain Ramp-Down) When in ALC mode, this is defined as the time that it takes for the PGA gain to ramp down across 90% of its range (e.g. from +20dB down to -21dB gain). When in limiter mode, it is defined as the time it takes for the gain to ramp down by 6dB.

The attack time can be programmed in power-of-two (2^n) steps, from 8.4ms, 16.8ms, 33.6ms etc. to 8.6s for the ALC and from 250us, 500us, etc. up to 256ms.

The time it takes for the recording level to return to its target value or static gain value therefore depends on both the attack/decay time and on the gain adjustment required. If the gain adjustment is small, it will be shorter than the attack/decay time.

| REGISTER ADDRESS | BIT | LABEL | DEFAULT | DESCRIPTION | |
|--|-----|-----------|---------|---|---|
| R18 (12h) 0010010 ALC Control 3 | 3:0 | ATK[3:0] | 0010 | LC attack (gain ramp-down) time | |
| | | | | ALC mode 0000: 8.4ms 0001: 16.8ms 0010: 33.6ms... (time doubles with every step) 1010 or higher: 8.6s | Limiter Mode 0000: 250us 0001: 500us... 0010: 1ms (time doubles with every step) 1010 or higher: 256ms |
| | 7:4 | DCY [3:0] | 0011 | LC decay (gain ramp-up) time | |
| | | | | ALC mode 0000: 33.5ms 0001: 67.2ms 0010: 134.4ms(time doubles for every step) 1010 or higher: 34.3ms | Limiter mode 0000: 1.2ms 0001: 2.4ms 0010: 4.8ms(time doubles for every step) 1010 or higher: 1.2288s |

TRANSIENT WINDOW (LIMITER ONLY)

To prevent the limiter responding to short duration high amplitude signals (such as hand-claps in a live performance), the limiter has a programmable transient window preventing it responding to signals above the threshold until their duration exceeds the window period. The Transient window is set in register TRANWIN.

| REGISTER ADDRESS | BIT | LABEL | DEFAULT | DESCRIPTION |
|---|-----|------------------|---------|---|
| R20 (14h) 0010100 Limiter Control | 6:4 | TRANWIN [2:0] | 010 | Length of Transient Window 000: 0us (disabled) 001: 62.5us 010: 125us 111: 4ms |

ZERO CROSS

The PGA has a zero cross detector to prevent gain changes introducing noise to the signal. In ALC mode the register bit ALCZC allows this to be turned off if desired.

| REGISTER ADDRESS | BIT | LABEL | DEFAULT | DESCRIPTION |
|---------------------------------------|-----|-------|-----------------|---|
| R17 (11h) 0010001 ALC Control 2 | 7 | ALCZC | 0 (disabled) | PGA zero cross enable 0 : disabled 1: enabled |

MAXIMUM GAIN (ALC ONLY) AND MAXIMUM ATTENUATION

To prevent low level signals being amplified too much by the ALC, the MAXGAIN register sets the upper limit for the gain. This prevents low level noise being over-amplified. The MAXGAIN register has no effect on the limiter operation.

The MAXATTEN register has different operation for the limiter and for the ALC. For the limiter it defines the maximum attenuation below the static (user programmed) gain. For the ALC, it defines the lower limit for the gain.

| REGISTER ADDRESS | BIT | LABEL | DEFAULT | DESCRIPTION |
|---|-----|----------|----------------|--|
| R16 (10h) 0010000 ALC Control 1 | 6:4 | MAXGAIN | 111 (+24dB) | Set maximum gain for the PGA (ALC only) 111 : +24dB 110 : +20dB(-4dB steps) 010 : +4dB 001 : 0dB 000 : 0dB |
| R20 (14h) 0010100 Limiter Control | 3:0 | MAXATTEN | 0110 | Maximum attenuation of PGA Limiter (attenuation below static) 0011 or lower: -3dB 0100: -4dB (-1dB steps) 1100 or higher: -12dB ALC (lower PGA gain limit) 1010 or lower: -1dB 1011 : -5dB (-4dB steps) 1110 : -17dB 1111 : -21dB |

HOLD TIME (ALC ONLY)

The ALC also has a hold time, which is the time delay between the peak level detected being below target and the PGA gain beginning to ramp up. It can be programmed in power-of-two (2^n) steps, e.g. 2.67ms, 5.33ms, 10.67ms etc. up to 43.7ms. Alternatively, the hold time can also be set to zero. The hold time only applies to gain ramp-up, there is no delay before ramping the gain down when the signal level is above target.

| REGISTER ADDRESS | BIT | LABEL | DEFAULT | DESCRIPTION |
|---------------------------------------|-----|----------|---------|---|
| R17 (11h) 0010001 ALC Control 2 | 3:0 | HLD[3:0] | 0000 | ALC hold time before gain is increased. 0000: 0ms 0001: 2.67ms 0010: 5.33ms ... (time doubles with every step) 1111: 43.691s |

OVERLOAD DETECTOR (ALC ONLY)

To prevent clipping when a large signal occurs just after a period of quiet, the ALC circuit includes an overload detector. If the ADC input signal exceeds 87.5% of full scale (-1.16dB), the PGA gain is ramped down at the maximum attack rate (as when ATK = 0000), until the signal level falls below 87.5% of full scale. This function is automatically enabled whenever the ALC is enabled.

(Note: If ATK = 0000, then the overload detector makes no difference to the operation of the ALC. It is designed to prevent clipping when long attack times are used).

NOISE GATE (ALC ONLY)

When the signal is very quiet and consists mainly of noise, the ALC function may cause “noise pumping”, i.e. loud hissing noise during silence periods. The WM8776 has a noise gate function that prevents noise pumping by comparing the signal level at the AINL1/2/3/4/5 and/or AINR1/2/3/4/5 pins against a noise gate threshold, NGTH. The noise gate cuts in when:

- Signal level at ADC [dB] < NGTH [dB] + PGA gain [dB] + Mic Boost gain [dB]

This is equivalent to:

- Signal level at input pin [dB] < NGTH [dB]

When the noise gate is triggered, the PGA gain is held constant (preventing it from ramping up as it would normally when the signal is quiet).

The table below summarises the noise gate control register. The NGTH control bits set the noise gate threshold with respect to the ADC full-scale range. The threshold is adjusted in 6dB steps. Levels at the extremes of the range may cause inappropriate operation, so care should be taken with set-up of the function. Note that the noise gate only works in conjunction with the ALC function, and always operates on the same channel(s) as the ALC (left, right, both, or none).

| REGISTER ADDRESS | BIT | LABEL | DEFAULT | DESCRIPTION |
|--|-----|-----------|---------|---|
| R19 (13h) 0010011 Noise Gate Control | 0 | NGAT | 0 | Noise gate function enable 1 = enable 0 = disable |
| | 4:2 | NGTH[2:0] | 000 | Noise gate threshold (with respect to ADC output level) 000: -78dBFS 001: -72dBfs ... 6 dB steps 110: -42dBFS 111: -36dBFS |

ADC INPUT MIXER AND POWERDOWN CONTROL

| REGISTER ADDRESS | BIT | LABEL | DEFAULT | DESCRIPTION |
|---|-----|----------|---------|---|
| R21 (15h) 0010101 ADC Input Mux | 4:0 | AMX[4:0] | 00001 | ADC left channel input mixer control bits (see Table 16) |
| R13 (0Dh) 0001101 Powerdown Control | 6 | AINPD | 0 | Input mux and buffer powerdown 0: Input mux and buffer enabled 1: Input mux and buffer powered down |

Register bits AMX[4:0] control the left and right channel inputs into the stereo ADC. The default is AIN1. One bit of AMX is allocated to each stereo input pair to allow the signals to be mixed before being digitised by the ADC. For example, if AMX[4:0] is 00101, the input signal to the ADC will be (AIN1L+AIN3L) on the left channel and (AIN1R+AIN3R) on the right channel.

However if the analogue input buffer is powered down, by setting AINPD, then all 5-channel mixer inputs are switched to buffered VMIDADC.

| AMX[4:0] | LEFT ADC INPUT | RIGHT ADC INPUT |
|----------|----------------|-----------------|
| 00001 | AIN1L | AIN1R |
| 00010 | AIN2L | AIN2R |
| 00100 | AIN3L | AIN3R |
| 01000 | AIN4L | AIN4R |
| 10000 | AIN5L | AIN5R |

Table 16 ADC Input Mixer

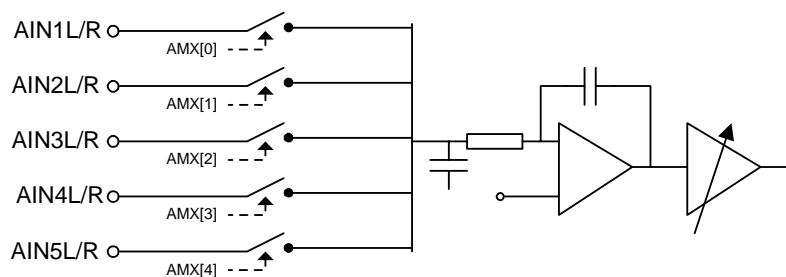

Figure 25 ADC Input Mixer

OUTPUT SELECT AND ENABLE CONTROL

Register bits MX controls the output selection. The output select block consists of a summing stage and an input select switch for each input allowing each signal to be output individually or summed with other signals and output on the analogue output. The default for the output is DAC playback only. VOUT may be selected to output DAC playback, AUX, analogue bypass or a sum of these using the output select controls MX[2:0]. For example, to select sum of DAC and AUX, set MX[2:0] to 011.

The output mixer is powered down with DACD.

| REGISTER ADDRESS | BIT | LABEL | DEFAULT | DESCRIPTION |
|------------------------------------|-----|---------|-----------------------|------------------------------------|
| R22 (16h) 0010110 Output Mux | 2:0 | MX[2:0] | 001 (DAC playback) | VOUT Output select (see Figure 26) |

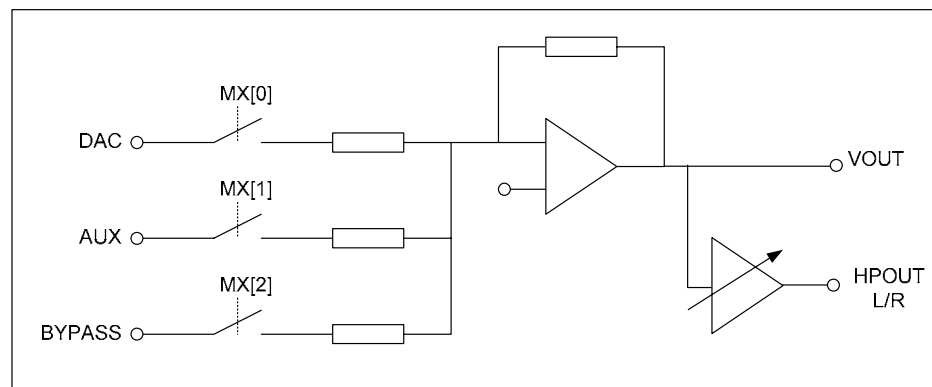

Figure 26 MX[2:0] Output Select

SOFTWARE REGISTER RESET

Writing any value to register 0010111 will cause a register reset, resetting all register bits to their default values.

REGISTER MAP

The complete register map is shown below. The detailed description can be found in the relevant text of the device description. The WM8776 can be configured using the Control Interface. All unused bits should be set to '0'.

| REGISTER | B15 | B14 | B13 | B12 | B11 | B10 | B9 | B8 | B7 | B6 | B5 | B4 | B3 | B2 | B1 | B0 | DEFAULT (HEX) |
|-----------|-----|-----|-----|-----|-----|-----|----|----------------|----------|--------------|------------|---------------|--------------|-------------|-------------|--------|---------------|
| R0 (00h) | 0 | 0 | 0 | 0 | 0 | 0 | 0 | UPDATE | HPLZCEN | HPLA[6:0] | | | | | | 079 | |
| R1 (01h) | 0 | 0 | 0 | 0 | 0 | 0 | 1 | UPDATE | HPRZCEN | HPRA[6:0] | | | | | | 079 | |
| R2 (02h) | 0 | 0 | 0 | 0 | 0 | 1 | 0 | UPDATEA | HPMZCEN | HPMASTA[6:0] | | | | | | 079 | |
| R3 (03h) | 0 | 0 | 0 | 0 | 0 | 1 | 1 | UPDATED | LDA[7:0] | | | | | | OFF | | |
| R4 (04h) | 0 | 0 | 0 | 0 | 1 | 0 | 0 | UPDATED | RDA[7:0] | | | | | | OFF | | |
| R5 (05h) | 0 | 0 | 0 | 0 | 1 | 0 | 1 | UPDATED | MASTDA | | | | | | OFF | | |
| R6 (06h) | 0 | 0 | 0 | 0 | 1 | 1 | 0 | 0 | 0 | 0 | 0 | 0 | 0 | 0 | PHASE[1:0] | | 000 |
| R7 (07h) | 0 | 0 | 0 | 0 | 1 | 1 | 1 | 0 | PL[3:0] | | | TOD | IZD | ATC | DZCEN | 090 | |
| R8 (08h) | 0 | 0 | 0 | 1 | 0 | 0 | 0 | 0 | 0 | 0 | 0 | 0 | 0 | 0 | 0 | DMUTE | 000 |
| R9 (09h) | 0 | 0 | 0 | 1 | 0 | 0 | 1 | 0 | 0 | 0 | 0 | 0 | 0 | DZFM[1:0] | | DEEMPH | 000 |
| R10 (0Ah) | 0 | 0 | 0 | 1 | 0 | 1 | 0 | 0 | 0 | DACWL[1:0] | | DACBCP | DACLR | DACFMT[1:0] | | 022 | |
| R11 (0Bh) | 0 | 0 | 0 | 1 | 0 | 1 | 1 | ADCHPD | 0 | ADCCLK | ADCWL[1:0] | | ADCBCP | ADCLR | ADCFMT[1:0] | | 022 |
| R12 (0Ch) | 0 | 0 | 0 | 1 | 1 | 0 | 0 | ADCMS | DACMS | DACRATE[2:0] | | ADCOSR | ADCRATE[2:0] | | | 022 | |
| R13 (0Dh) | 0 | 0 | 0 | 1 | 1 | 0 | 1 | 0 | 0 | AINPD | 0 | 0 | HPPD | DACPD | ADCPD | PDWN | 008 |
| R14 (0Eh) | 0 | 0 | 0 | 1 | 1 | 1 | 0 | ZCLA | LAG[7:0] | | | | | | 0CF | | |
| R15 (0Fh) | 0 | 0 | 0 | 1 | 1 | 1 | 1 | ZCRA | RAG[7:0] | | | | | | 0CF | | |
| R16 (10h) | 0 | 0 | 1 | 0 | 0 | 0 | 0 | LCSEL[1:0] | | MAXGAIN[2:0] | | LCT[3:0] | | | 07B | | |
| R17 (11h) | 0 | 0 | 1 | 0 | 0 | 0 | 1 | LCEN | ALCZC | 0 | 0 | 0 | HLD[3:0] | | | 000 | |
| R18 (12h) | 0 | 0 | 1 | 0 | 0 | 1 | 0 | FDECAY | DCY[3:0] | | | ATK[3:0] | | | 032 | | |
| R19 (13h) | 0 | 0 | 1 | 0 | 0 | 1 | 1 | 0 | 0 | 0 | 0 | NGTH[2:0] | | 0 | NGAT | 000 | |
| R20 (14h) | 0 | 0 | 1 | 0 | 1 | 0 | 0 | 0 | 1 | TRANWIN[2:0] | | MAXATTEN[3:0] | | | 0A6 | | |
| R21 (15h) | 0 | 0 | 1 | 0 | 1 | 0 | 1 | LRBOTH | MUTELA | MUTERA | 0 | AMX[4:0] | | | 001 | | |
| R22 (16h) | 0 | 0 | 1 | 0 | 1 | 1 | 0 | 0 | 0 | 0 | | | MX[2:0] | | 001 | | |
| R23 (17h) | 0 | 0 | 1 | 0 | 1 | 1 | 1 | SOFTWARE RESET | | | | | | | | | not reset |

| REGISTER ADDRESS | BIT | LABEL | DEFAULT | DESCRIPTION |
|--|-----|--------------|-------------------|---|
| R0 (00h) 0000000 Headphone Analogue Attenuation Headphone Left | 6:0 | HPLA[6:0] | 1111001 (0dB) | Attenuation data for HEADPHONE left channel in 1dB steps. |
| | 7 | HPLZCEN | 0 | Left HEADPHONE zero cross detect enable 0: zero cross disabled 1: zero cross enabled |
| | 8 | UPDATE | Not latched | Controls simultaneous update of all Attenuation Latches 0: Store HPLA in intermediate latch (no change to output) 1: Store HPLA and update attenuation on all channels. |
| R1 (01h) 0000001 Headphone Analogue Attenuation Headphone Right | 6:0 | HPRA[6:0] | 1111001 (0dB) | Attenuation data for Headphone right channel in 1dB steps. |
| | 7 | HPRZCEN | 0 | Right Headphone zero cross detect enable 0: zero cross disabled 1: zero cross enabled |
| | 8 | UPDATE | Not latched | Controls simultaneous update of all Attenuation Latches 0: Store HPRA in intermediate latch (no change to output) 1: Store HPRA and update attenuation on all channels. |
| R2 (02h) 0000010 Headphone Master Analogue Attenuation (All Channels) | 6:0 | HPMASTA[6:0] | 1111001 (0dB) | Attenuation data for all ANALOGUE gains (L and R channels) in 1dB steps. |
| | 7 | MZCEN | 0 | Master zero cross detect enable 0: zero cross disabled 1: zero cross enabled |
| | 8 | UPDATEA | Not latched | Controls simultaneous update of all Attenuation Latches 0: Store gains in intermediate latch (no change to output) 1: Store gains and update attenuation on all channels. |
| R3 (03h) 0000011 Digital Attenuation DACL | 7:0 | LDA1[7:0] | 11111111 (0dB) | Digital Attenuation data for Left channel DACL in 0.5dB steps. |
| | 8 | UPDATED | Not latched | Controls simultaneous update of all Attenuation Latches 0: Store LDA1 in intermediate latch (no change to output) 1: Store LDA1 and update attenuation on all channels |
| R4 (04h) 0000100 Digital Attenuation DACR | 7:0 | RDA1[6:0] | 11111111 (0dB) | Digital Attenuation data for Right channel DACR in 0.5dB steps. |
| | 8 | UPDATED | Not latched | Controls simultaneous update of all Attenuation Latches 0: Store RDA1 in intermediate latch (no change to output) 1: Store RDA1 and update attenuation on all channels. |
| R5 (05h) 0000101 Master Digital Attenuation (All Channels) | 7:0 | MASTDA[7:0] | 11111111 (0dB) | Digital Attenuation data for all DAC channels in 0.5dB steps. |
| | 8 | UPDATED | Not latched | Controls simultaneous update of all Attenuation Latches 0: Store gain in intermediate latch (no change to output) 1: Store gain and update attenuation on all channels. |

| REGISTER ADDRESS | BIT | LABEL | DEFAULT | DESCRIPTION | | | | | | |
|------------------------------------|-----|---------|---------|---|---------------------|-------------|---------------------|---------|-------------|--------------|
| R6 (06h) 0000110 Phase Swaps | 1:0 | PHASE | 00 | Controls phase of DAC outputs (LEFT, RIGHT channel) 0: Sets non inverted output phase 1: inverts phase of DAC output | | | | | | |
| R7 (07h) 0000111 DAC Control | 0 | DZCEN | 0 | DAC Digital Volume Zero Cross Enable: 0: Zero Cross detect disabled 1: Zero Cross detect enabled | | | | | | |
| | 1 | ATC | 0 | Attenuator Control 0: All DACs use attenuations as programmed. 1: Right DAC uses left DAC attenuations | | | | | | |
| | 2 | IZD | 0 | Infinite zero detection circuit control and automute control 0: Infinite zero detect automute disabled 1: Infinite zero detect automute enabled | | | | | | |
| | 3 | TOD | 0 | DAC and ADC Analogue Zero cross detect timeout disable 0 : Timeout enabled 1: Timeout disabled | | | | | | |
| | 7:4 | PL[3:0] | 1001 | DAC Output Control | | | | | | |
| | | | | | PL[3:0] | Left Output | Right Output | PL[3:0] | Left Output | Right Output |
| | | | | | 0000 | Mute | Mute | 1000 | Mute | Right |
| | | | | | 0001 | Left | Mute | 1001 | Left | Right |
| | | | | | 0010 | Right | Mute | 1010 | Right | Right |
| | | | | 0011 | (L+R)/2 | Mute | 1011 | (L+R)/2 | Right | |
| | | | | 0100 | Mute | Left | 1100 | Mute | (L+R)/2 | |
| | | | | 0101 | Left | Left | 1101 | Left | (L+R)/2 | |
| | | | | 0110 | Right | Left | 1110 | Right | (L+R)/2 | |
| | | | | 0111 | (L+R)/2 | Left | 1111 | (L+R)/2 | (L+R)/2 | |
| R8 (08h) 0001000 DAC Mute | 0 | DMUTE | 0 | DAC channel soft mute enables: 0: mute disabled 1: mute enabled | | | | | | |
| R9 (09h) 0001001 DAC Control | 0 | DEEMPH | 0 | De-emphasis mode select: 0 : Normal Mode 1: De-emphasis Mode | | | | | | |
| | 2:1 | DZFM | 00 | DZFM | ZFLAG1 | | ZFLAG2 | | | |
| | | | | 00 | disabled | | disabled | | | |
| | | | | 01 | left channels zero | | right channels zero | | | |
| | | | | 10 | both channels zero | | both channels zero | | | |
| | | | | 11 | either channel zero | | either channel zero | | | |

| REGISTER ADDRESS | BIT | LABEL | DEFAULT | DESCRIPTION |
|---|------------|-------------|---|---|
| R10 (0Ah) 0001010 DAC Interface Control | 1:0 | DACFMT[1:0] | 10 | DAC Interface format select 00: right justified mode 01: left justified mode 10: I ² S mode 11: DSP mode |
| | 2 | DACLRP | 0 | DACLRC Polarity or DSP Early/Late mode select |
| | | | | Left Justified / Right Justified / I ² S 0: Standard DACLRC Polarity 1: Inverted DACLRC Polarity |
| | 3 | DACBCP | 0 | DAC BITCLK Polarity 0: Normal – DIN and DACLRC sampled on rising edge of DACBCLK. 1: Inverted - DIN and DACLRC sampled on falling edge of DACBCLK. |
| 5:4 | DACWL[1:0] | 10 | DAC Input Word Length 00: 16-bit Mode 01: 20-bit Mode 10: 24-bit Mode 11: 32-bit Mode (not supported in right justified mode) | |
| R11 (0Bh) 0001011 ADC Interface Control | 1:0 | ADCFMT[1:0] | 10 | ADC Interface format select 00: right justified mode 01: left justified mode 10: I ² S mode 11: DSP mode |
| | 2 | ADCLRP | 0 | ADCLRC Polarity or DSP Early/Late mode select |
| | | | | Left Justified / Right Justified / I ² S 0: Standard ADCLRC Polarity 1: Inverted ADCLRC Polarity |
| | 3 | ADCBCP | 0 | ADC BITCLK Polarity 0: Normal - ADCLRC sampled on rising edge of ADCBCLK; DOUT changes on falling edge of ADCBCLK. 1: Inverted - ADCLRC sampled on falling edge of ADCBCLK; DOUT changes on rising edge of ADCBCLK. |
| | 5:4 | ADCWL[1:0] | 10 | ADC Input Word Length 00: 16-bit Mode 01: 20-bit Mode 10: 24-bit Mode 11: 32-bit Mode (not supported in right justified mode) |
| | 6 | ADCMCLK | 0 | ADCMCLK Polarity: 0: non-inverted 1: inverted |
| | 8 | ADCHPD | 0 | ADC Highpass Filter Disable: |
| 0: Highpass Filter enabled 1: Highpass Filter disabled | | | | |

| REGISTER ADDRESS | BIT | LABEL | DEFAULT | DESCRIPTION |
|---|--|--------------|----------------|--|
| R12 (0Ch) 0001100 Master Mode Control | 2:0 | ADCRATE[2:0] | 010 | Master Mode ADCMCLK:ADCLRC ratio select: 010: 256fs 011: 384fs 100: 512fs |
| | 3 | ADCOSR | 0 | ADC oversample rate select 0: 128x oversampling 1: 64x oversampling |
| | 6:4 | DACRATE[2:0] | 010 | Master Mode DACMCLK:DACLRC ratio select: 000: 128fs 001: 192fs 010: 256fs 011: 384fs 100: 512fs |
| | 7 | DACMS | 0 | DAC Maser/Slave interface mode select 0: Slave Mode – DACLRC and DACBCLK are inputs 1: Master Mode – DACLRC and DACBCLK are outputs |
| | 8 | ADCMS | 0 | ADC Maser/Slave interface mode select 0: Slave Mode – ADCLRC and ADCBCLK are inputs 1: Master Mode – ADCLRC and ADCBCLK are outputs |
| | R13 (0Dh) 0001101 PWR Down Control | 0 | PDWN | 0 |
| 1 | | ADCPD | 0 | ADC powerdown: 0: ADC enabled 1: ADC disabled |
| 2 | | DACPD | 0 | DAC powerdown 0: DAC enabled 1: DAC disabled |
| 3 | | HPPD | 1 | Headphone Output/PGA's powerdown 0: Headphone out enabled 1: Headphone out disabled |
| 6 | | AINPD | 0 | AINPD powerdown 0: ANALOGUE INPUT enabled 1: ANALOGUE INPUT disabled |
| R14 (0Eh) 0001110 Attenuation ADCL | 7:0 | LAG[7:0] | 11001111 (0dB) | Attenuation data for left channel ADC gain in 0.5dB steps. 00000000 : digital mute 00000001 : -103dB 11001111 : 0dB 11111110 : +23.5dB 11111111 : +24dB |
| | 8 | ZCLA | 0 | Left ADC zero cross enable: 0: Zero cross disabled 1: Zero cross enabled |

| REGISTER ADDRESS | BIT | LABEL | DEFAULT | DESCRIPTION |
|---|-----|--------------|-----------------------|---|
| R15 (0Fh) 0001111 Attenuation ADCR | 7:0 | RAG[7:0] | 11001111 (0dB) | Attenuation data for right channel ADC gain in 0.5dB steps. 00000000 : digital mute 00000001 : -103dB 11001111 : 0dB 11111110 : +23.5dB 11111111 : +24dB |
| | 8 | ZCRA | 0 | Right ADC zero cross enable: 0: Zero cross disabled 1: Zero cross enabled |
| R16 (10h) 0010000 ALC Control 1 | 3:0 | LCT[3:0] | 1011 (-5dB) | Limiter threshold/ALC target level in 1dB steps 0000: -16dB FS 0001: -15dB FS ... 1101: -3dB FS 1110: -2dB FS 1111: -1dB FS |
| | 6:4 | MAXGAIN[2:0] | 111 (+24dB) | Set Maximum Gain of PGA 111 : +24dB 110 : +20dB ...(-4dB steps) 010 : +4dB 001 : 0dB 000 : 0dB |
| | 8:7 | LCSEL[1:0] | 00 (Limiter) | ALC/Limiter function select 00 = Limiter 01 = ALC Right channel only 10 = ALC Left channel only 11 = ALC Stereo (PGA registers unused) |
| R17 (11h) 0010001 ALC Control 2 | 3:0 | HLD[3:0] | 0000 (OFF) | ALC hold time before gain is increased. 0000: OFF 0001: 2.67ms 0010: 5.33ms ... (time doubles with every step) 1111: 43.691s |
| | 7 | ALCZC | 0 (zero cross off) | ALC uses zero cross detection circuit. |
| | 8 | LCEN | 0 | Enable Gain control circuit. 0 = Disable 1 = Enable |

| REGISTER ADDRESS | BIT | LABEL | DEFAULT | DESCRIPTION |
|---|-----|-------------------|---------------------------|--|
| R18 (12h) 0011000 ALC Control 3 | 3:0 | ATK[3:0] | 0010 (33ms/1ms) | ALC/Limiter attack (gain ramp-down) time ALC mode 0000: 8.4ms 0001: 16.8ms 0010: 33.6ms... (time doubles with every step) 1010 or higher: 8.6s Limiter Mode 0000: 250us 0001: 500us... 0010: 1ms (time doubles with every step) 1010 or higher: 256ms |
| | 7:4 | DCY[3:0] | 0011 (268ms/ 9.6ms) | ALC/Limiter decay (gain ramp up) time ALC mode 0000: 33.5ms 0001: 67.2ms 0010: 134.4ms ...(time doubles for every step) 1010 or higher: 34.3ms Limiter mode 0000: 1.2ms 0001: 2.4ms 0010: 4.8ms ...(time doubles for every step) 1010 or higher: 1.2288s |
| R19 (13h) 0010011 Noise Gate Control | 0 | NGAT | 0 | Noise gate enable (ALC only) 0 : disabled 1 : enabled |
| | 4:2 | NGTH [2:0] | 000 | Noise gate threshold 000: -78dBFS 001: -72dBfs ... 6 dB steps 110: -42dBFS 111: -36dBFS |
| R20 (14h) 0010100 Limiter Control | 3:0 | MAXATTEN [3:0] | 0110 | Maximum attenuation of PGA Limiter (attenuation below static) 0011 or lower: -3dB 0100: -4dB (-1dB steps) 1100 or higher: -12dB ALC (lower PGA gain limit) 1010 or lower: -1dB 1011 : -5dB (-4dB steps) 1110 : -17dB 1111 : -21dB |
| | 6:4 | TRANWIN [2:0] | 010 | Length of Transient Window 000: 0us (disabled) 001: 62.5us 010: 125us 111: 4ms |
| R21 (15h) 0010101 ADC Mux Control | 4:0 | AMX[4:0] | 00001 | ADC left channel input mixer control bit AMX[4:0] ADC LEFT IN ADC RIGHT IN 00001 AIN1L AIN1R 00010 AIN2L AIN2L 00100 AIN3L AIN3R 01000 AIN4L AIN4R 10000 AIN5L AIN5R |
| | 6 | MUTERA | 0 | Mute for right channel ADC 0: Mute off 1: Mute on |
| | 7 | MUTELA | 0 | Mute for left channel ADC 0: Mute off 1: Mute on |

| REGISTER ADDRESS | BIT | LABEL | DEFAULT | DESCRIPTION |
|--|-------|---------|-----------|---|
| | 8 | LRBOTH | 0 | Right channel input PGA controlled by left channel register 0 : Right channel uses RAG and MUTERA. 1 : Right channel uses LAG and MUTELA. |
| R22 (16h) 0010110 Output Mux | 2:0 | MX[2:0] | 001 | VOUT Output select (Analogue ByPass Enable / Disable) 001: DAC 010: AUX 100: BYPASS |
| R23 (17h) 0010111 Software Reset | [8:0] | RESET | Not reset | Writing to this register will apply a reset to the device registers. |

DIGITAL FILTER CHARACTERISTICS

| PARAMETER | TEST CONDITIONS | MIN | TYP | MAX | UNIT |
|----------------------|-----------------|----------|-----------|------------|------|
| ADC Filter | | | | | |
| Passband | ± 0.01 dB | 0 | | 0.4535fs | |
| | -6dB | | 0.5fs | | |
| Passband ripple | | | | ± 0.01 | dB |
| Stopband | | 0.5465fs | | | |
| Stopband Attenuation | $f > 0.5465fs$ | -65 | | | dB |
| Group Delay | | | 22 | | fs |
| DAC Filter | | | | | |
| Passband | ± 0.05 dB | | | 0.454fs | |
| | -3dB | | 0.4892 fs | | |
| Passband ripple | | | | ± 0.05 | dB |
| Stopband | | 0.546fs | | | |
| Stopband Attenuation | $f > 0.546fs$ | -60 | | | dB |
| Group Delay | | | 19 | | fs |

Table 17 Digital Filter Characteristics

DAC FILTER RESPONSES

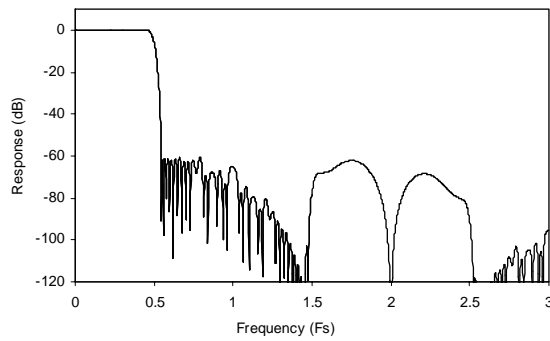

Figure 27 DAC Digital Filter Frequency Response – 44.1, 48 and 96kHz

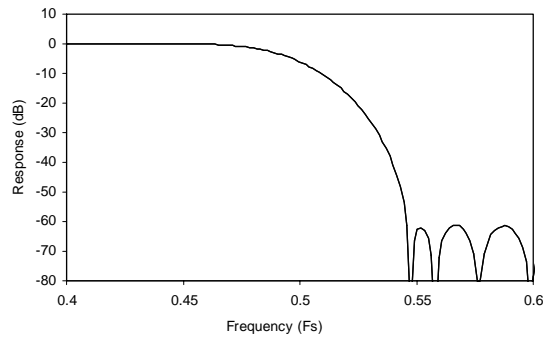

Figure 28 DAC Digital Filter Transition Band – 44.1, 48 and 96kHz

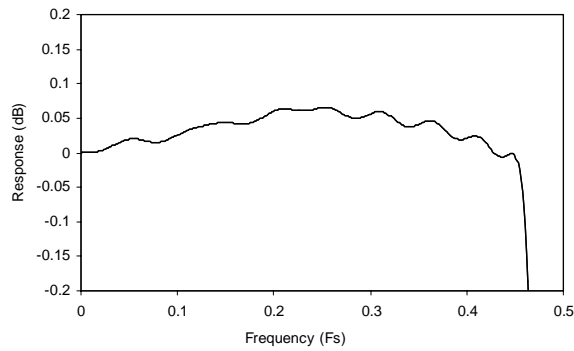

Figure 29 DAC Digital Filter Ripple – 44.1, 48 and 96kHz

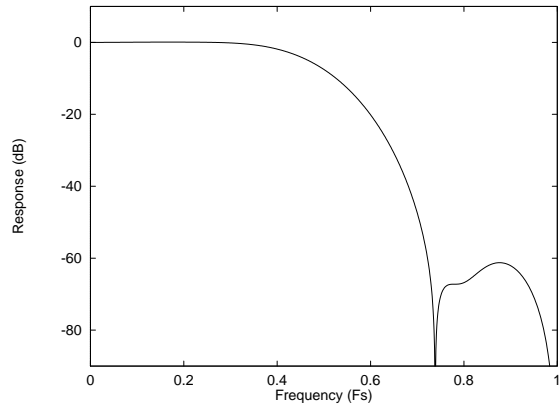

Figure 30 DAC Digital Filter Frequency Response – 192kHz

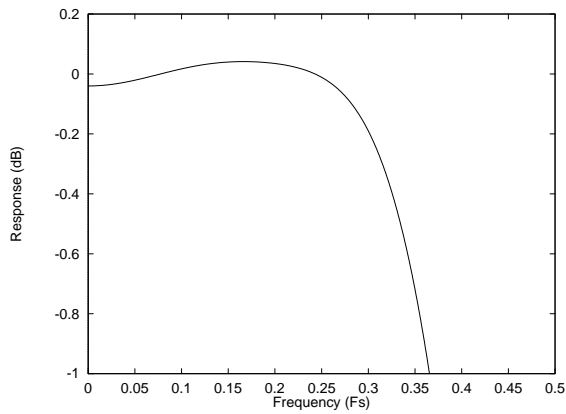

Figure 31 DAC Digital filter Ripple - 192kHz

ADC FILTER RESPONSES

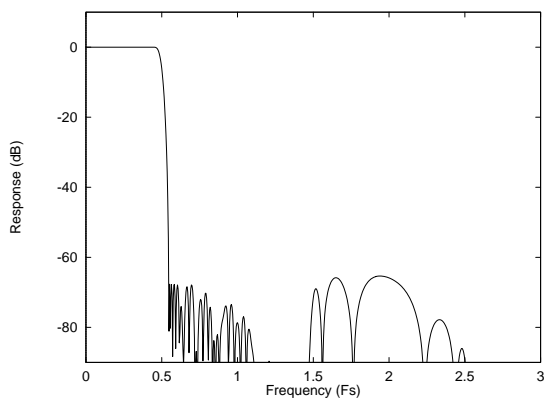

Figure 32 ADC Digital Filter Frequency Response

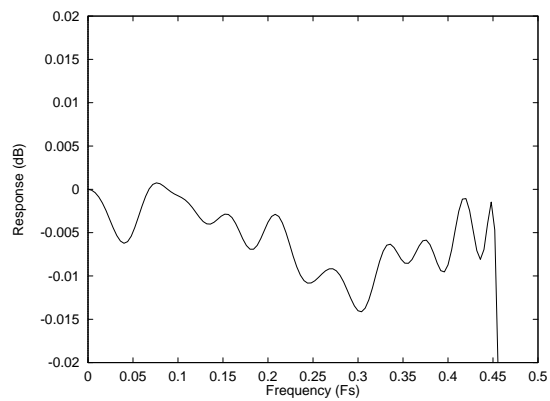

Figure 33 ADC Digital Filter Ripple

ADC HIGH PASS FILTER

The WM8776 has a selectable digital highpass filter to remove DC offsets. The filter response is characterised by the following polynomial.

$$H(z) = \frac{1 - z^{-1}}{1 - 0.9995z^{-1}}$$

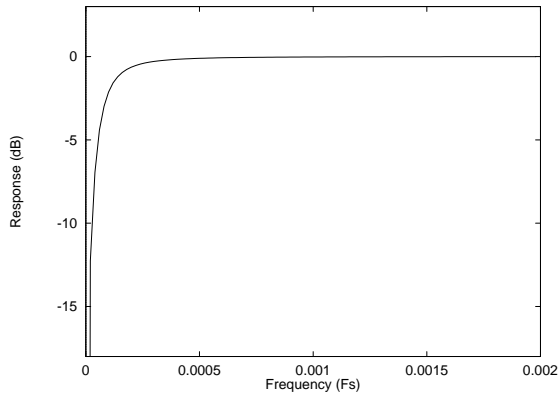

Figure 34 ADC Highpass Filter Response

DIGITAL DE-EMPHASIS CHARACTERISTICS

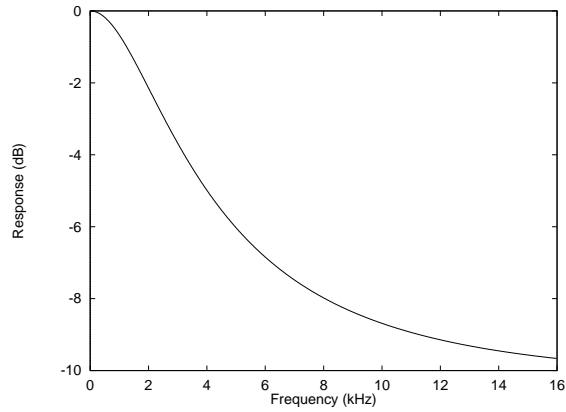

Figure 35 De-Emphasis Frequency Response (32kHz)

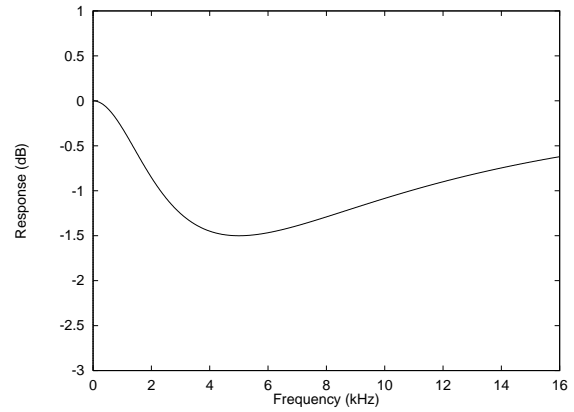

Figure 36 De-Emphasis Error (32kHz)

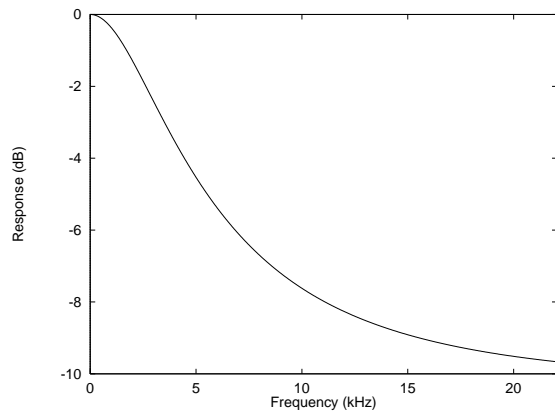

Figure 37 De-Emphasis Frequency Response (44.1kHz)

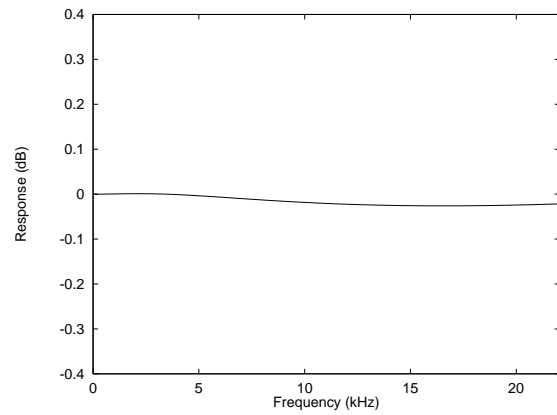

Figure 38 De-Emphasis Error (44.1kHz)

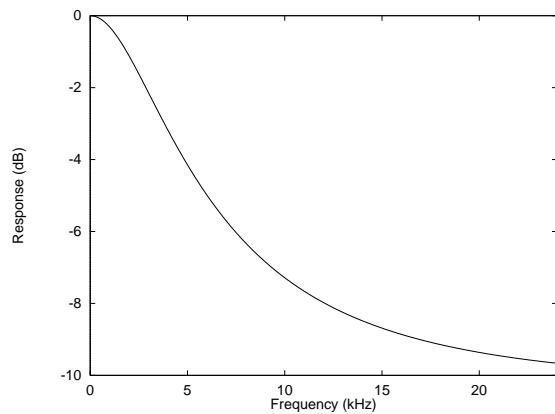

Figure 39 De-Emphasis Frequency Response (48kHz)

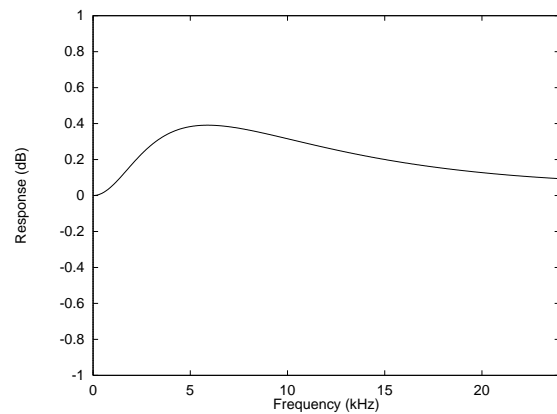

Figure 40 De-Emphasis Error (48kHz)

APPLICATIONS INFORMATION

EXTERNAL CIRCUIT CONFIGURATION

In order to allow the use of 2V rms and larger inputs to the ADC and AUX inputs, a structure is used that uses external resistors to drop these larger voltages. This also increases the robustness of the circuit to external abuse such as ESD pulses. Figure 41 shows the ADC input multiplexor circuit with external components allowing 2Vrms inputs to be applied.

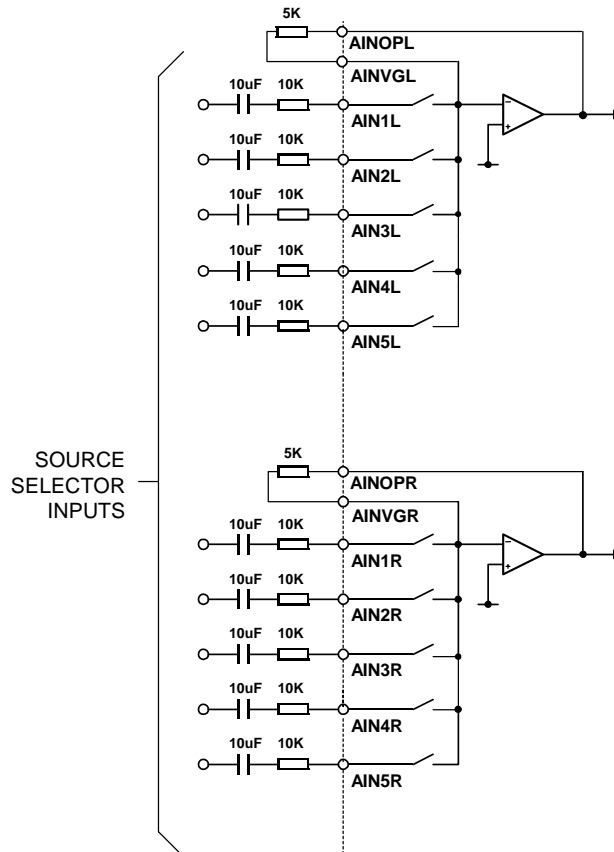

Figure 41 ADC Input Multiplexor Configuration

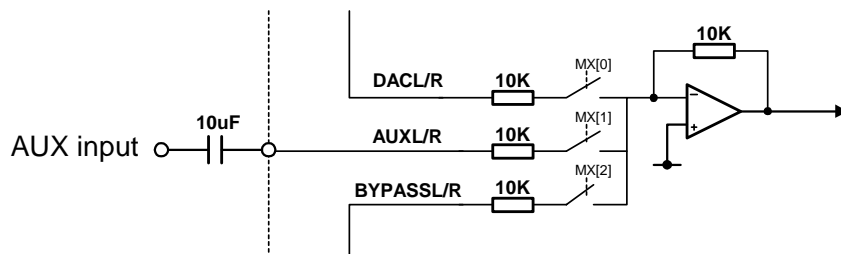

Figure 42 5.1 Channel Input Multiplexor Configuration

RECOMMENDED EXTERNAL COMPONENTS

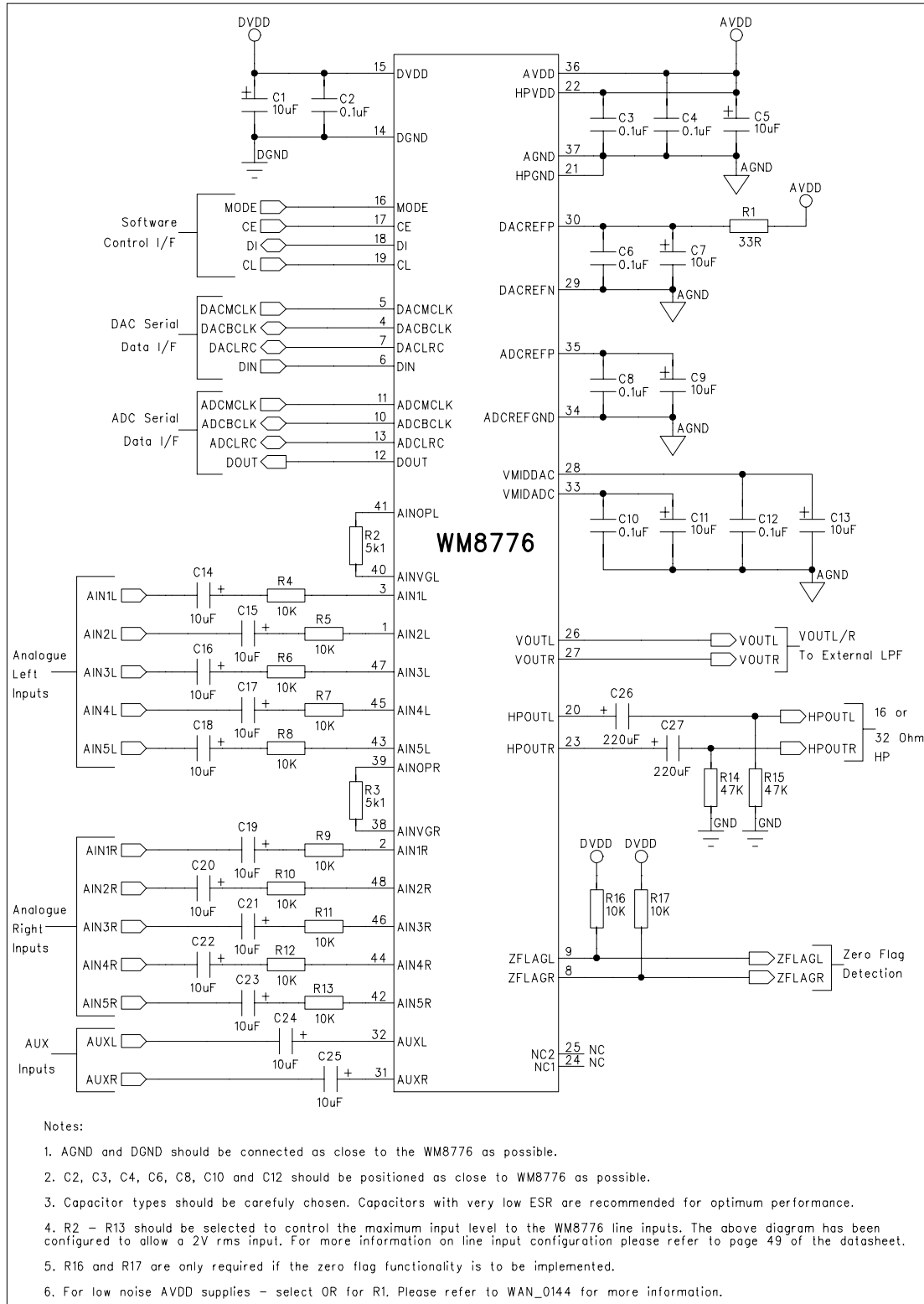

Figure 43 External Component Diagram

It is recommended that a low pass filter be applied to the output from the DAC for hi-fi applications. Typically a second order filter is suitable and provides sufficient attenuation of high frequency components (the unique low order, high bit count multi-bit sigma delta DAC structure used in WM8776 produces much less high frequency output noise). This filter is typically also used to provide the 2x gain needed to provide the standard 2Vrms output level from most consumer equipment. Figure 44 shows a suitable post DAC filter circuit, with 2x gain. Alternative inverting filter architectures might also be used with as good results.

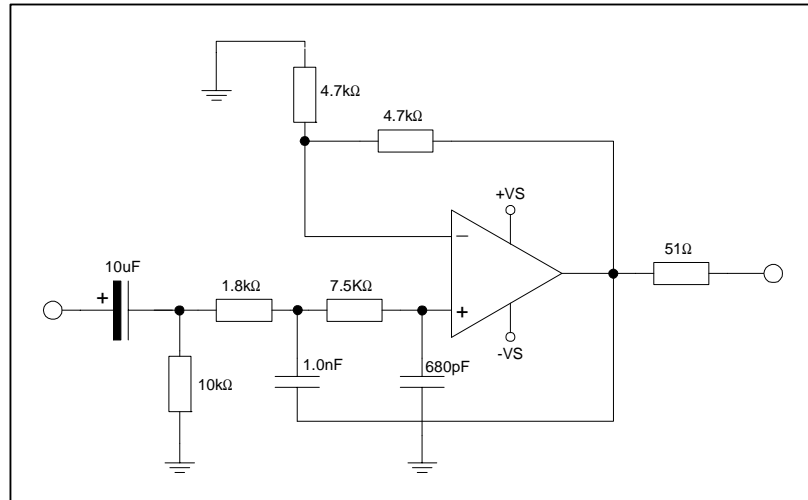
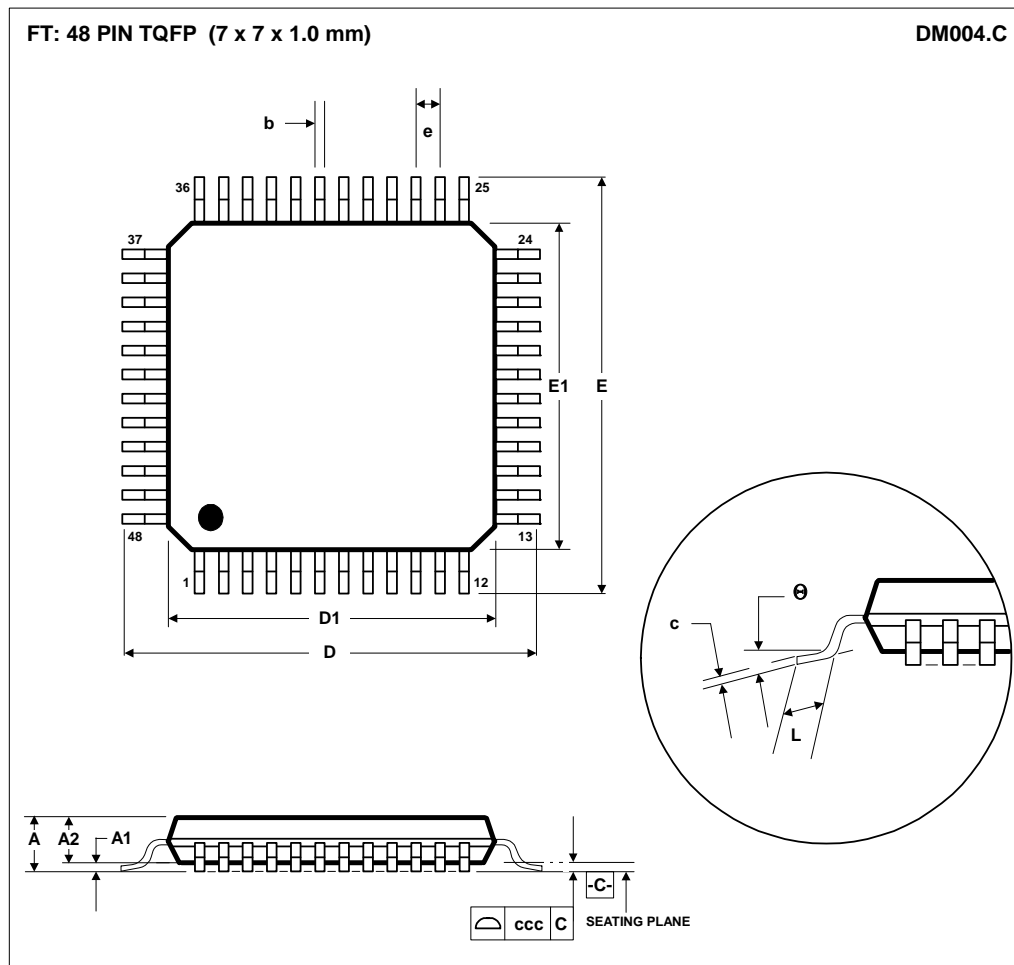

Figure 44 Recommended Post DAC Filter Circuit

PACKAGE DIMENSIONS



| Symbols | Dimensions (mm) | | |
|---------------------------------|------------------|------|------|
| | MIN | NOM | MAX |
| A | ---- | ---- | 1.20 |
| A ₁ | 0.05 | ---- | 0.15 |
| A ₂ | 0.95 | 1.00 | 1.05 |
| b | 0.17 | 0.22 | 0.27 |
| c | 0.09 | ---- | 0.20 |
| D | 9.00 BSC | | |
| D ₁ | 7.00 BSC | | |
| E | 9.00 BSC | | |
| E ₁ | 7.00 BSC | | |
| e | 0.50 BSC | | |
| L | 0.45 | 0.60 | 0.75 |
| θ | 0° | 3.5° | 7° |
| Tolerances of Form and Position | | | |
| ccc | 0.08 | | |
| REF: | JEDEC.95, MS-026 | | |

NOTES:
 A. ALL LINEAR DIMENSIONS ARE IN MILLIMETERS.
 B. THIS DRAWING IS SUBJECT TO CHANGE WITHOUT NOTICE.
 C. BODY DIMENSIONS DO NOT INCLUDE MOLD FLASH OR PROTRUSION, NOT TO EXCEED 0.25MM.
 D. MEETS JEDEC.95 MS-026, VARIATION = ABC. REFER TO THIS SPECIFICATION FOR FURTHER DETAILS.

IMPORTANT NOTICE

Wolfson Microelectronics plc ("Wolfson") products and services are sold subject to Wolfson's terms and conditions of sale, delivery and payment supplied at the time of order acknowledgement.

Wolfson warrants performance of its products to the specifications in effect at the date of shipment. Wolfson reserves the right to make changes to its products and specifications or to discontinue any product or service without notice. Customers should therefore obtain the latest version of relevant information from Wolfson to verify that the information is current.

Testing and other quality control techniques are utilised to the extent Wolfson deems necessary to support its warranty. Specific testing of all parameters of each device is not necessarily performed unless required by law or regulation.

In order to minimise risks associated with customer applications, the customer must use adequate design and operating safeguards to minimise inherent or procedural hazards. Wolfson is not liable for applications assistance or customer product design. The customer is solely responsible for its selection and use of Wolfson products. Wolfson is not liable for such selection or use nor for use of any circuitry other than circuitry entirely embodied in a Wolfson product.

Wolfson's products are not intended for use in life support systems, appliances, nuclear systems or systems where malfunction can reasonably be expected to result in personal injury, death or severe property or environmental damage. Any use of products by the customer for such purposes is at the customer's own risk.

Wolfson does not grant any licence (express or implied) under any patent right, copyright, mask work right or other intellectual property right of Wolfson covering or relating to any combination, machine, or process in which its products or services might be or are used. Any provision or publication of any third party's products or services does not constitute Wolfson's approval, licence, warranty or endorsement thereof. Any third party trade marks contained in this document belong to the respective third party owner.

Reproduction of information from Wolfson datasheets is permissible only if reproduction is without alteration and is accompanied by all associated copyright, proprietary and other notices (including this notice) and conditions. Wolfson is not liable for any unauthorised alteration of such information or for any reliance placed thereon.

Any representations made, warranties given, and/or liabilities accepted by any person which differ from those contained in this datasheet or in Wolfson's standard terms and conditions of sale, delivery and payment are made, given and/or accepted at that person's own risk. Wolfson is not liable for any such representations, warranties or liabilities or for any reliance placed thereon by any person.

ADDRESS:

Wolfson Microelectronics plc
Westfield House
26 Westfield Road
Edinburgh
EH11 2QB
United Kingdom

Tel :: +44 (0)131 272 7000

Fax :: +44 (0)131 272 7001

Email :: sales@wolfsonmicro.com