

## Multimedia AC'97 CODEC with Integrated Touch Screen Controller

### DESCRIPTION

The WM9705 is a high-quality stereo audio codec with an integrated touch screen controller.

The audio section is compliant with the Intel AC'97 Rev 2.2 specification. It performs full-duplex 18-bit codec functions and supports variable sample rates from 8 to 48k samples/s with high signal to noise ratio. Optional AC'97 features include 3D sound enhancement, line-level outputs, stereo buffered headphone outputs, hardware sample rate conversion, primary/secondary mode operation and S/PDIF output. Headphone auto-detect, I<sup>2</sup>S output and headphone buffer on the mono output are included.

Additionally, the WM9705 integrates a complete 4-wire touch screen controller, including on-chip screen drivers, pen-down detection feature, and pressure measurement capability.

A 5-pin digital bi-directional AC-Link serial interface allows transfer of control data and DAC and ADC words to and from the AC'97 controller. The WM9705 is fully operable on 3V or 5V or mixed 3/5V supplies, and is packaged in the industry standard 48-pin TQFP package with 7mm body size, or in a smaller 7 × 7 × 0.9mm QFN.

### BLOCK DIAGRAM

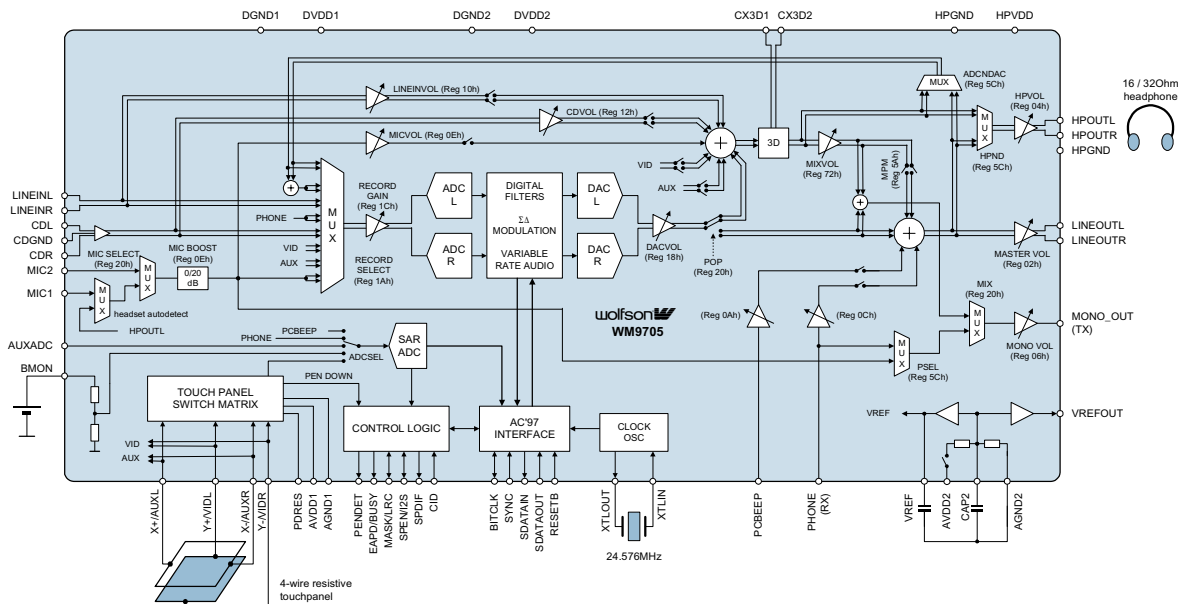

### FEATURES

- AC'97 rev2.2 compliant codec with pen digitiser
- 18-bit stereo audio codecs
- On-chip sample rate conversion
- Multiple channel input mixer
- S/PDIF digital audio output
- Headphone drivers on AUX and MONO outputs
- 4-wire touch screen interface with co-ordinate and pressure measurement, and pen-down detection
- Wake-up from sleep mode on pen down
- 3V to 5V operation
- Extensive power management features including hardware power down option
- Standard AC'97 pinout in 48-pin TQFP package or 48-pin QFN package.

### APPLICATIONS

- Personal Digital Assistants and 'Smartphones'
- PocketPC systems

## TABLE OF CONTENTS

<b>DESCRIPTION .....</b>	<b>1</b>
<b>FEATURES.....</b>	<b>1</b>
<b>APPLICATIONS .....</b>	<b>1</b>
<b>BLOCK DIAGRAM .....</b>	<b>1</b>
<b>TABLE OF CONTENTS .....</b>	<b>2</b>
<b>ORDERING INFORMATION .....</b>	<b>4</b>
<b>ABSOLUTE MAXIMUM RATINGS.....</b>	<b>4</b>
<b>RECOMMENDED OPERATING CONDITIONS .....</b>	<b>5</b>
<b>PIN CONFIGURATION.....</b>	<b>6</b>
<b>PIN DESCRIPTION .....</b>	<b>7</b>
<b>ELECTRICAL CHARACTERISTICS .....</b>	<b>8</b>
<b>POWER CONSUMPTION .....</b>	<b>12</b>
<b>DETAILED TIMING DIAGRAMS .....</b>	<b>13</b>
AC-LINK LOW POWER MODE .....	13
COLD RESET.....	13
WARM RESET .....	14
CLOCK SPECIFICATIONS .....	14
DATA SETUP AND HOLD (50PF EXTERNAL LOAD).....	15
SIGNAL RISE AND FALL TIMES .....	15
<b>DEVICE DESCRIPTION.....</b>	<b>16</b>
INTRODUCTION.....	16
AC'97 FEATURES.....	16
NON - AC'97 FEATURES.....	17
PEN DIGITIZER AND AUXILIARY ADC .....	19
3-D STEREO ENHANCEMENT .....	19
VARIABLE SAMPLE RATE SUPPORT .....	20
SPDIF OR I <sup>2</sup> S DIGITAL AUDIO DATA OUTPUT .....	20
PRIMARY/SECONDARY ID SUPPORT .....	21
HEADPHONE DRIVE AND HEADSET AUTODETECT .....	21
DATA SLOT MAPPING .....	23
AC-LINK DIGITAL SERIAL INTERFACE PROTOCOL .....	23
AC-LINK AUDIO OUTPUT FRAME (SDATAOUT) .....	25
AC-LINK AUDIO INPUT FRAME (SDATAIN) .....	27
AC-LINK LOW POWER MODE .....	29
WAKING UP THE AC-LINK.....	29
SERIAL INTERFACE REGISTER MAP DESCRIPTION.....	30
REGISTER 28H – EXTENDED AUDIO ID.....	34
REGISTER 2AH – EXTENDED AUDIO STATUS AND CONTROL REGISTER.....	35
REGISTER 2CH AND 32H – AUDIO SAMPLE RATE CONTROL REGISTERS.....	35
REGISTERS 3AH – SPDIF CONTROL REGISTER .....	36
VENDOR SPECIFIC REGISTERS (INDEX 5AH - 7AH) .....	36
<b>SERIAL INTERFACE REGISTER MAP .....</b>	<b>39</b>

---

<b>PEN DIGITISER OPERATION .....</b>	<b>40</b>
TIMING OF PEN DIGITISER OPERATIONS.....	41
CONTROL OF PEN DIGITISER FUNCTIONS .....	41
READBCK OF PEN DIGITISER RESULTS.....	42
CONVERSION CONTROL .....	43
PRESSURE MEASUREMENT .....	48
MASK FUNCTION.....	49
STANDBY OPERATION AND WAKE-UP.....	50
AUXILIARY CONVERSIONS.....	51
<b>PACKAGE DIMENSIONS - TQFP.....</b>	<b>53</b>
<b>PACKAGE DIMENSIONS - QFN.....</b>	<b>54</b>
<b>IMPORTANT NOTICE .....</b>	<b>55</b>
ADDRESS:.....	55

**ORDERING INFORMATION**

DEVICE	TEMP. RANGE	PACKAGE	MOISTURE SENSITIVITY LEVEL
XWM9705EFT/V	-25 to 85°C	48-pin TQFP	MSL1
WM9705SEFT/V	-25 to 85°C	48-pin TQFP (lead free)	MSL1
XWM9705EFT/RV	-25 to 85°C	48-pin TQFP (tape and reel)	MSL1
WM9705SEFT/RV	-25 to 85°C	48-pin TQFP (lead free, tape and reel)	MSL1

DEVICE	TEMP. RANGE	PACKAGE	MOISTURE SENSITIVITY LEVEL
XWM9705EFL/V	-25 to 85°C	48-pin QFN	MSL3
WM9705SEFL/V	-25 to 85°C	48-pin QFN (lead free)	MSL3
XWM9705EFL/RV	-25 to 85°C	48-pin QFN (tape and reel)	MSL3
WM9705SEFL/RV	-25 to 85°C	48-pin QFN (lead free, tape and reel)	MSL3

**Note:**

Reel quantity = 2,200

**ABSOLUTE MAXIMUM RATINGS**

Absolute Maximum Ratings are stress ratings only. Permanent damage to the device may be caused by continuously operating at or beyond these limits. Device functional operating limits and guaranteed performance specifications are given under Electrical Characteristics at the test conditions specified.



ESD Sensitive Device. This device is manufactured on a CMOS process. It is therefore generically susceptible to damage from excessive static voltages. Proper ESD precautions must be taken during handling and storage of this device.

Wolfson tests its package types according to IPC/JEDEC J-STD-020B for Moisture Sensitivity to determine acceptable storage conditions prior to surface mount assembly. These levels are:

MSL1 = unlimited floor life at <30°C / 85% Relative Humidity. Not normally stored in moisture barrier bag.

MSL2 = out of bag storage for 1 year at <30°C / 60% Relative Humidity. Supplied in moisture barrier bag.

MSL3 = out of bag storage for 168 hours at <30°C / 60% Relative Humidity. Supplied in moisture barrier bag.

The Moisture Sensitivity Level for each package type is specified in Ordering Information.

**Note:**

The TQFP version is classified as MSL1 and does not require to be drybagged but will be supplied as such, labelled as MSL1.

CONDITION	MIN	MAX
Digital supply voltage	-0.3V	+7V
Analogue supply voltage	-0.3V	+7V
Voltage range digital inputs	DVSS -0.3V	DVDD +0.3V
Voltage range analogue inputs	AVDD -0.3V	AVDD +0.3V
Operating temperature range, T <sub>A</sub>	-25°C	+85°C
Storage temperature after soldering	-65°C	+150°C
Package body temperature (soldering 10 seconds)		+240°C
Package body temperature (soldering 2 minutes)		+183°C

**RECOMMENDED OPERATING CONDITIONS**

PARAMETER	SYMBOL	TEST CONDITIONS	MIN	TYP	MAX	UNIT
Digital supply range	DVDD1, DVDD2		2.7		5.5	V
Analogue supply range	AVDD1, AVDD2		2.7		5.5	V
Digital ground	DGND1, DGND2			0		V
Analogue ground	AGND1, AGND2, HPGND			0		V
Difference AGND to DGND – Note 1			-0.3	0	+0.3	V
Difference AVDD to DVDD – Note 2			-0.3		5.5	V

**Note:**

1. AGND is normally the same as DGND and HPGND
2. AVDD should be greater than or equal to DVDD

PIN CONFIGURATION

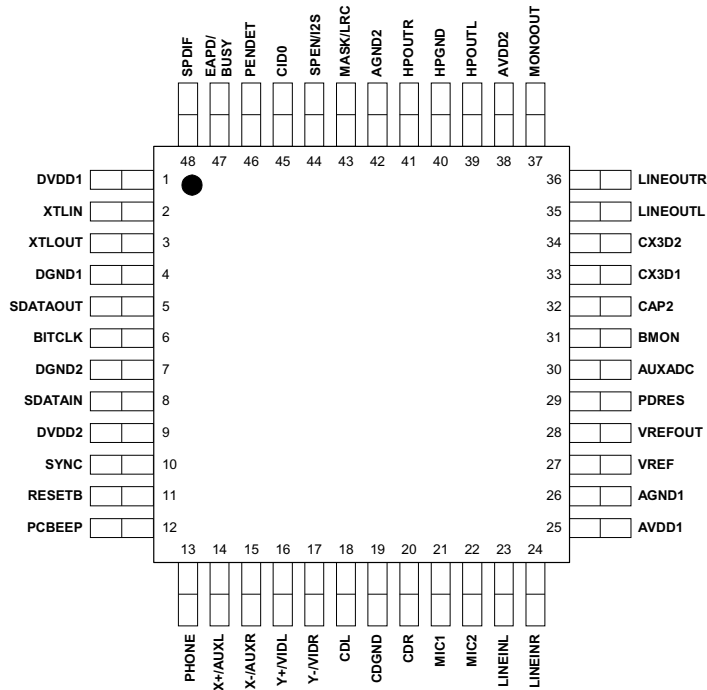

Figure 1 TQFP Pinout

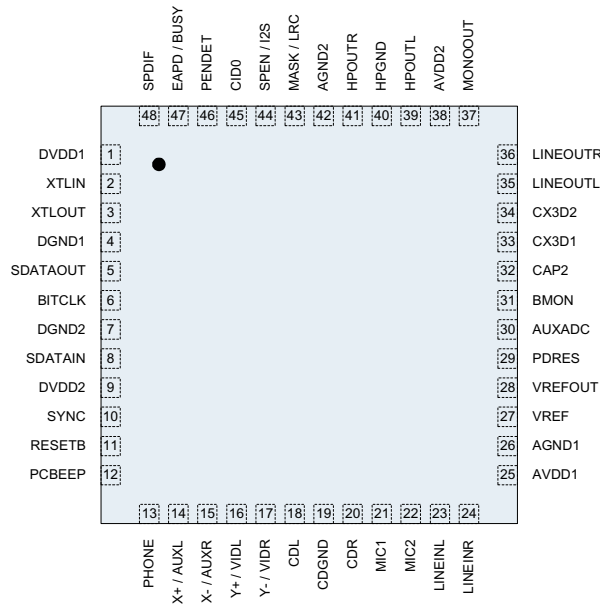

Figure 2 QFN Pinout

## PIN DESCRIPTION

PIN	48 PIN QFN	48 PIN TQFP	TYPE	DESCRIPTION
1	DVDD1	DVDD1	Supply	Digital positive supply
2	XTLIN	XTLIN	Digital input	Clock crystal connection or clock input (XTAL not used)
3	XTLOUT	XTLOUT	Digital output	Clock crystal connection
4	DGND1	DGND1	Supply	Digital ground supply
5	SDATAOUT	SDATAOUT	Digital input	Serial data input
6	BITCLK	BITCLK	Digital output Digital input	Serial interface clock output to AC'97 controller or input from AC'97 primary codec
7	DGND2	DGND2	Supply	Digital ground supply
8	SDATAIN	SDATAIN	Digital output	Serial data output to AC'97 controller
9	DVDD2	DVDD2	Supply	Digital positive supply
10	SYNC	SYNC	Digital input	Serial interface sync pulse from AC'97 controller
11	RESETB	RESETB	Digital input	NOT reset input (active low, resets registers)
12	PCBEEP	PCBEEP	Analogue input	Mixer input, typically for PCBEEP signal (also input to AUX ADC)
13	PHONE	PHONE	Analogue input	PHONE input (also input to AUX ADC)
14	X+/AUXL	X+/AUXL	Analogue I/O	Pen X+ channel screen driver/input. (or AUXL mixer input)
15	X-/AUXR	X-/AUXR	Analogue I/O	Pen X- channel screen driver/input (or AUXR mixer input)
16	Y+/VIDL	Y+/VIDL	Analogue I/O	Pen Y+ channel screen driver/input (or VIDL mixer input)
17	Y-/VIDR	Y-/VIDR	Analogue I/O	Pen Y- channel screen driver/input (or VIDR mixer input)
18	CDL	CDL	Analogue input	Mixer input, typically for CD signal
19	CDGND	CDGND	Analogue input	CD input common mode reference (ground)
20	CDR	CDR	Analogue input	Mixer input, typically for CD signal
21	MIC1	MIC1	Analogue input	Mixer input with extra gain if required – also HSET detect input
22	MIC2	MIC2	Analogue input	Mixer input with extra gain if required
23	LINEINL	LINEINL	Analogue input	Mixer input, typically for LINE signal
24	LINEINR	LINEINR	Analogue input	Mixer input, typically for LINE signal
25	AVDD1	AVDD1	Supply	Analogue positive supply for screen drivers
26	AGND1	AGND1	Supply	Analogue ground supply for screen drivers
27	VREF	VREF	Analogue output	Internal reference (buffered CAP2)
28	VREFOUT	VREFOUT	Analogue output	Reference for microphones (buffered CAP2)
29	PDRES	PDRES	Analogue input	Pen Down Detect Pull-up external resistor connection
30	AUXADC	AUXADC	Analogue input	AUX signal input to digitiser ADC
31	BMON	BMON	Analogue input	Battery input to ADC
32	CAP2	CAP2	Analogue I/O	Reference input/output; pulls to midrail if not overdriven
33	CX3D1	CX3D1	Analogue output	Output pin for 3D difference signal
34	CX3D2	CX3D2	Analogue input	Input pin for 3D difference signal
35	LINEOUTL	LINEOUTL	Analogue output	Main analogue output for left channel
36	LINEOUTR	LINEOUTR	Analogue output	Main analogue output for right channel
37	MONOOUT	MONOOUT	Analogue output	Main mono output
38	AVDD2	AVDD2	Supply	Analogue positive supply
39	HPOUTL	HPOUTL	Analogue output	Left channel line level output (or headphone, or headset mic input)
40	HPGND	HPGND	Supply	Headphone ground supply
41	HPOUTR	HPOUTR	Analogue output	Right channel line level output (or headphone)
42	AGND2	AGND2	Supply	Analogue ground supply
43	MASK/LRC	MASK/LRC	Digital bidir	MASK input signal to delay PEN conversions (or LRCLK output)
44	SPEN/I <sup>2</sup> S	SPEN/I <sup>2</sup> S	Digital bidir	SPDIF hardware enable pin and I <sup>2</sup> S data output
45	CID0	CID0	Digital input	Primary/Secondary ID select (internal pull-up) Hi = Primary
46	PENDET	PENDET	Digital output	Pen Down Detection flag OR Headset detect output
47	EAPD/BUSY	EAPD/BUSY	Digital output	External amplifier powerdown or BUSY output flag from Pen ADC
48	SPDIF	SPDIF	Digital output	S/PDIF output

## ELECTRICAL CHARACTERISTICS

### Test Characteristics:

AVDD = 3.3V, DVDD = 3.3V, 48kHz audio sampling,  $T_A = 25^\circ\text{C}$ , unless otherwise stated.

PARAMETER	SYMBOL	TEST CONDITIONS	MIN	TYP	MAX	UNIT
<b>Digital Logic Levels (DVDD = 3.3V)</b>						
Input LOW level	$V_{IL}$		DGND - 0.3		0.8	V
Input HIGH level	$V_{IH}$		2.2		DVDD + 0.3	V
Output LOW	$V_{OL}$	I Load = 2mA			0.10 x DVDD	V
Output HIGH	$V_{OH}$	I Load = -2mA	0.90 x DVDD			V
<b>Analogue Audio I/O Levels (Input Signals on any audio inputs, Outputs on LINEOUT L, R and MONO and HPOUT L,R)</b>						
Input level		Minimum input impedance = 10k	AGND -100mV		AVDD +100mV	V
Output level to LINEOUT L,R		Into 10k $\Omega$ load	AGND +300mV	Near rail to rail	AVDD -300mV	V
Output level to HPOUT L, HPOUT R and MONOOUT		Into 16 $\Omega$ load	AGND +300mV	Near rail to rail	AVDD -300mV	V
<b>Reference Levels</b>						
Reference input/output	CAP2		0.47 AVDD	0.50 AVDD	0.53 AVDD	V
CAP2 impedance				75		k $\Omega$
Mixer reference	VREF			Buffered CAP2		V
MIC reference	VREFOUT			Buffered CAP2		V
MIDBUFF current source (pins VREF and VREFOUT)		AVDD = 3.3V	5	10		mA
MIDBUFF current sink (pins VREF and VREFOUT)		AVDD = 3.3V	-5	-10		mA
<b>AUDIO DAC to Line-out (10k<math>\Omega</math> load)</b>						
SNR A-weighted (Note 2)			85	91		dB
Full scale output voltage		VREF = 1.65V		0.7		Vrms
Total Harmonic Distortion + Noise	THD+N	-3dBfs input		-84 0.006	-74 0.02	dB %
PSRR		20 to 20kHz, without supply decoupling		-40		dB
<b>AUDIO ADC</b>						
ADC input for full scale output		VREF = 1.65V		0.7		Vrms
Signal to Noise Ratio A-weighted (Note 2)	SNR		80	86		dBfs
Total Harmonic Distortion+Noise	THD+N	-6dBfs input		-79	-72	dB
Power Supply Rejection Ratio	PSRR	20 to 20kHz, without supply decoupling		-40		dB
<b>Digital Filter Characteristics</b>						
Frequency response			20		19,200	Hz
Transition band			19,200		28,800	Hz
Stop band			28,800			Hz
Stop band attenuation		ADC	-74			dB
		DAC	-40			



**Test Characteristics:**AVDD = 3.3V, DVDD = 3.3V, 48kHz audio sampling, T<sub>A</sub> = 25°C, unless otherwise stated.

PARAMETER	SYMBOL	TEST CONDITIONS	MIN	TYP	MAX	UNIT
<b>Mixer Inputs to Line-out (10kΩ load)</b>						
Maximum input voltage			AGND	0.7	AVDD	V <sub>rms</sub>
Maximum output voltage		on LINEOUT		0.7		V <sub>rms</sub>
Signal to Noise Ratio A-weighted (Note 2)	SNR	CD inputs	90	92		dB
		Other inputs	82	93		
Total Harmonic Distortion + Noise -1dBfs input	THD+N	CD and LINE inputs		-87 0.0044	-77 0.014	dB %
		PHONE input		-82 0.008	-71 0.028	
		MIC1 input		-82 0.008	-71 0.028	
		MIC2 input		-90 0.003	-71 0.028	
		PCBEEP input		-78 0.013	-67 0.045	
Input impedance (CD inputs)		At any gain		15		kΩ
Input impedance (other mixer inputs)		At max gain	10	20		kΩ
		At 0db gain	50	100		kΩ
Input impedance MIC inputs		At max gain	10	20		kΩ
		At 0db gain	55	100		kΩ
Power Supply Rejection Ratio	PSRR	20 to 20kHz, without supply decoupling		-40		dB
<b>Headphone Buffer (pins HPOUTL, HPOUR and MONOOUT)</b>						
Maximum output voltage				0.7		V <sub>rms</sub>
Max Output Power (Note 1)	P <sub>O</sub>	RL = 32Ω		30		mW
		RL = 16Ω		40		mW
SNR (Note 2)		A-weighted	85	92		dB
Total Harmonic Distortion + Noise	THD+N	1kHz, R <sub>L</sub> = 32Ω @ P <sub>O</sub> = 10mW rms		-80 0.01		dB %
		1kHz, R <sub>L</sub> = 32Ω @ P <sub>O</sub> = 20mW rms		-77 0.014		dB %
		1kHz, R <sub>L</sub> = 16Ω @ P <sub>O</sub> = 10mW rms		-76dB 0.016		dB %
		1kHz, R <sub>L</sub> = 16Ω @ P <sub>O</sub> = 20mW rms		-75dB 0.018		dB %
Power Supply Rejection Ratio	PSRR	20 to 20kHz, without supply decoupling		-40		dB
<b>Clocks</b>						
Crystal clock				24.576		MHz
BITCLK frequency				12.288		MHz
SYNC frequency				48.0		KHz

**Test Characteristics:**AVDD = 3.3V, DVDD = 3.3V, MCLK = 24.576MHz, T<sub>A</sub> = 25°C, unless otherwise stated.

PARAMETER	SYMBOL	TEST CONDITIONS	MIN	TYP	MAX	UNIT
<b>PEN and AUXILIARY INPUT ADC</b>						
Resolution				12		Bits
Differential non-linearity error	DNL			+/-0.25		LSB
Integral non-linearity error	INL			+/-2		LSB
Offset error				+/-4		LSB
Gain error				+/-4		LSB
Noise				500		μVrms
Conversion time				20.8		μsec
Acquisition time				15		μsec
Throughput rate					48	kHz
Multiplexer settling time				500		nsec
ADC positive reference		X conversion		X+ pin		V
		Y conversion		Y+ pin		
		auxiliary conversion		AVDD1		
ADC negative reference		X conversion		X- pin		V
		Y conversion		Y- pin		
		auxiliary conversion		AGND1		
ADC sampling capacitance				2		pF
AUXADC input range (fullscale)			AGND1		AVDD1	
AUXADC input leakage current				+/-0.5		μA
BMON input range			AGND1		6.5V	
BMON input impedance		at sampling time		30		kΩ
BMON <i>effective</i> input impedance (Note 3)		93.75Hz sample rate		7.7		MΩ
BMON input gain				1/3		
<b>PEN INTERFACE</b>						
Full scale input range				AVDD		V
Absolute input range		Positive input		AVDD		V
		Negative input		0		
Capacitance				5		pF
Leakage current				+/-0.5		μA
Screen switch on resistance				20		Ω
Pressure measurement current		PIL = 0		200		μA
		PIL = 1		400		
External Pen-detect pull up resistor value			1	10	100	kΩ
Pen Detect Comparator Threshold DAC Range	PDDACR		0.1		1.65	V
Pen Detect Comparator Threshold DAC step size	PDDACLSB			0.1		V

**Note:**

1. Harmonic distortion on the headphone output decreases with output power – see Figure 3.
2. SNR is the ratio of 0dB signal amplitude to noise floor with no signal present (all 0s input code to DACs).
3. The input impedance of the BMON input is 30k to ground when the ADC is sampling and hi-Z when it is not. The effective input resistance is calculated dependant on how often the battery is sampled by the user. 7.7MΩ is the effective impedance if the battery is sampled once every 512 frames. For a fuller description of this and information on how to calculate the effect input impedance please see the section on auxiliary conversions on pages 46.
4. ADC sampling capacitance allows the user to calculate the minimum external capacitance required for a stable ADC value.

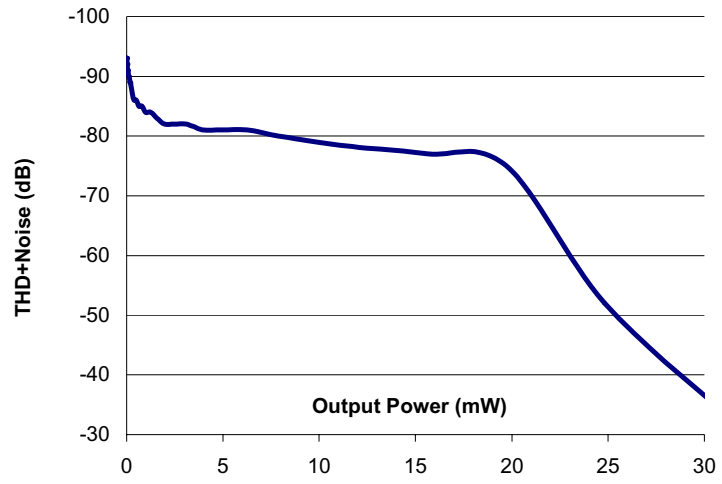

Figure 3 Distortion Versus Power on Headphone Outputs, using 32Ω Load and AVDD = HPVDD = 3.3V

## POWER CONSUMPTION

MODE DESCRIPTION	PR0	PR1	PR2	PR3	PR4	PR5	PR6	EAPD	DIGITISER PD REG 78H (PRP)	RECORD MUX	CURRENT CONSUMPTION		TOTAL POWER (mW)
											AVDD (mA)	DVDD (mA)	
<b>Record and Playback</b>													
Mic Record (note 1)	0	0	0	0	0	0	0	X	00	000L 000R	14.8	14.3	96
Other Input Record	0	0	0	0	0	0	0	X	00	001L 001R	17.7	14.3	105.6
Other Input Record PR6	0	0	0	0	0	0	1	X	00	001L 001R	16.3	14.3	101
Other Input Record PR6 and PR2	0	0	1	0	0	0	1	X	00	001L 001R	10.7	14.3	82.5
Other Input Record PR6 and PR3	0	0	0	1	0	0	1	X	00	001L 001R	0.5	14.1	48.2
<b>Playback Only</b>													
Low Power Playback (note 2)	1	0	1	0	0	0	0	X	00	001L 001R	5.5	11.5	56.1
Playback Only	1	0	0	0	0	0	0	X	00	001L 001R	11.1	11.5	74.6
Playback Only PR6	1	0	0	0	0	0	1	X	00	001L 001R	9.7	11.5	70
Playback Only PR6 and PR2	1	0	1	0	0	0	1	X	00	001L 001R	4.0	11.5	51.2
Playback Only PR6 and PR3	1	0	0	1	0	0	1	X	00	001L 001R	0.4	11.5	39.3
<b>Record Only</b>													
Mic Record (note 1)	0	1	0	0	0	0	0	X	00	000L 000R	12.9	13.3	86.5
Other Input Record	0	1	0	0	0	0	0	X	00	100L 100R	15.8	13.3	96
Other Input Record PR6	0	1	0	0	0	0	1	X	00	100L 100R	14.3	11.3	84.5
Other Input Record PR6 and PR2	0	1	1	0	0	0	1	X	00	100L 100R	7.2	13.3	67.7
Other Input Record PR6 and PR3	0	1	0	1	0	0	1	X	00	100L 100R	0.3	12.9	43.6
<b>Power Down</b>													
Power Down (note 3)	1	1	1	1	1	1	1	X	00	XXXL XXXR	0.0001	0.002	0.007
<b>Pen Digitiser</b>													
Pen Digitiser (Note 4)	1	1	1	1	0	1	1	X	11	XXXL XXXR	0.1	3.6	12.2

**Notes:**

- When the ADC input mux is set to mic input to BOTH ADC channels, (SR2-0 and SL2-0 both set to '0'), one ADC is shared between both channels and the other is powered off to save current. The same digital data is output to both slots.
- The POP bit (reg 20h) also needs to be set for this mode.
- These values are recorded with no external clocks applied to the WM9705.
- Pen active duty cycle is approximately 10%. Average analogue current consumption is approximately 10% of stated figure.

## DETAILED TIMING DIAGRAMS

**Test Characteristics:**

AVDD = 3.3V, DVDD = 3.3V, AGND = 0V ..... $T_A = 0^{\circ}\text{C}$  to  $+70^{\circ}\text{C}$ , unless otherwise stated.

All measurements are taken at 10% to 90% DVDD, unless otherwise stated. All the following timing information is guaranteed, not tested.

### AC-LINK LOW POWER MODE

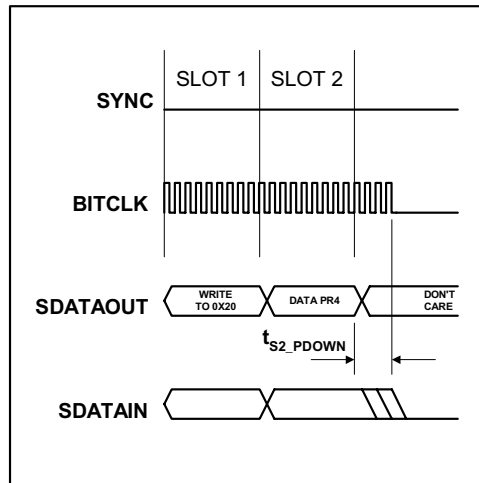

Figure 4 AC-Link Powerdown Timing

PARAMETER	SYMBOL	MIN	TYP	MAX	UNIT
End of slot 2 to BITCLK SDATAIN low	$t_{s2\_PDOW}$			1.0	$\mu\text{s}$

### COLD RESET

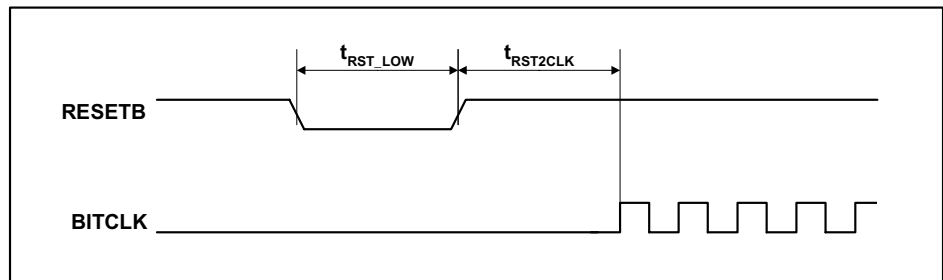

Figure 5 Cold Reset Timing

**Note:**

For correct operation SDATAOUT and SYNC must be held LOW for entire RESETB active low period otherwise the device may enter test mode. See AC'97 specification or Wolfson applications note WAN104 for more details.

PARAMETER	SYMBOL	MIN	TYP	MAX	UNIT
RESETB active low pulse width	$t_{RST\_LOW}$	1.0			$\mu\text{s}$
RESETB inactive to BITCLK startup delay	$t_{RST2CLK}$	162.8			ns

**WARM RESET**

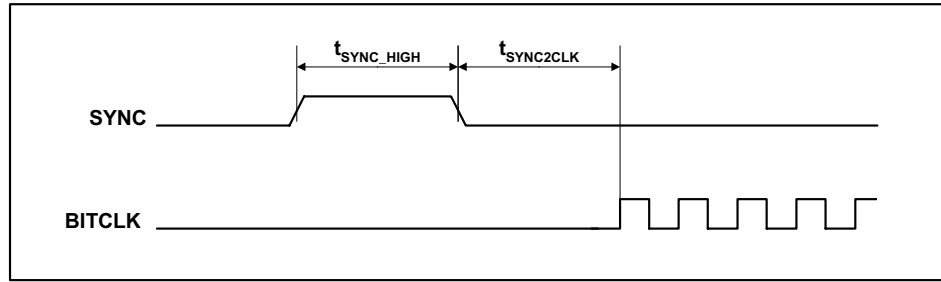

Figure 6 Warm Reset Timing

PARAMETER	SYMBOL	MIN	TYP	MAX	UNIT
SYNC active high pulse width	$t_{\text{SYNC\_HIGH}}$		1.3		$\mu\text{s}$
SYNC inactive to BITCLK startup delay	$t_{\text{SYNC2CLK}}$	162.4			ns

**CLOCK SPECIFICATIONS**

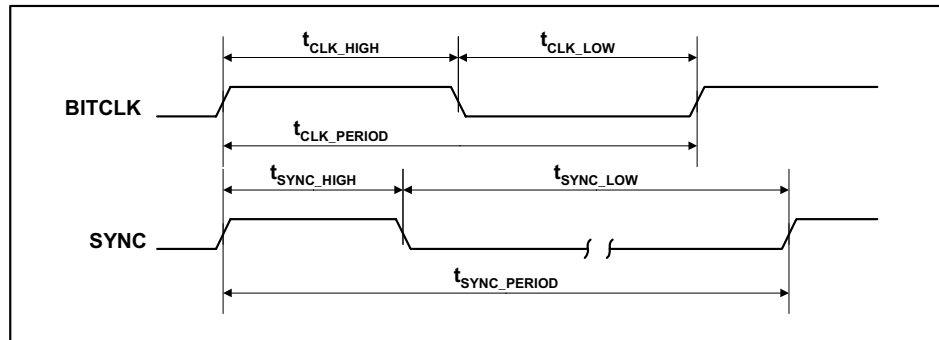

Figure 7 Clock Specifications (50pF External Load)

PARAMETER	SYMBOL	MIN	TYP	MAX	UNIT
BITCLK frequency			12.288		MHz
BITCLK period	$t_{\text{CLK\_PERIOD}}$		81.4		ns
BITCLK output jitter				750	ps
BITCLK high pulse width (Note 1)	$t_{\text{CLK\_HIGH}}$	36	40.7	45	ns
BITCLK low pulse width (Note 1)	$t_{\text{CLK\_LOW}}$	36	40.7	45	ns
SYNC frequency			48.0		kHz
SYNC period	$t_{\text{SYNC\_PERIOD}}$		20.8		$\mu\text{s}$
SYNC high pulse width	$t_{\text{SYNC\_HIGH}}$		1.3		$\mu\text{s}$
SYNC low pulse width	$t_{\text{SYNC\_LOW}}$		19.5		$\mu\text{s}$

**Note:**

Worst case duty cycle restricted to 45/55.

**DATA SETUP AND HOLD (50PF EXTERNAL LOAD)**

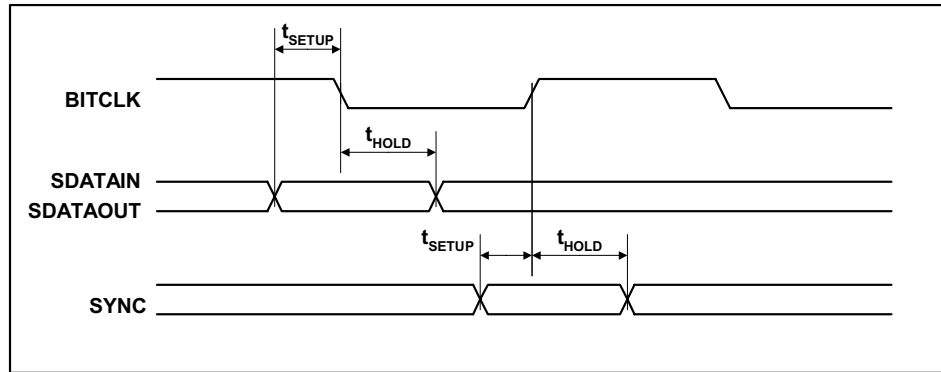

**Figure 8 Data Setup and Hold (50pF External Load)**

**Note:**

Setup and hold time parameters for SDATAIN are with respect to AC'97 Controller.

PARAMETER	SYMBOL	MIN	TYP	MAX	UNIT
Setup to falling edge of BITCLK	$t_{SETUP}$	10			ns
Hold from falling edge of BITCLK	$t_{HOLD}$	10			ns

**SIGNAL RISE AND FALL TIMES**

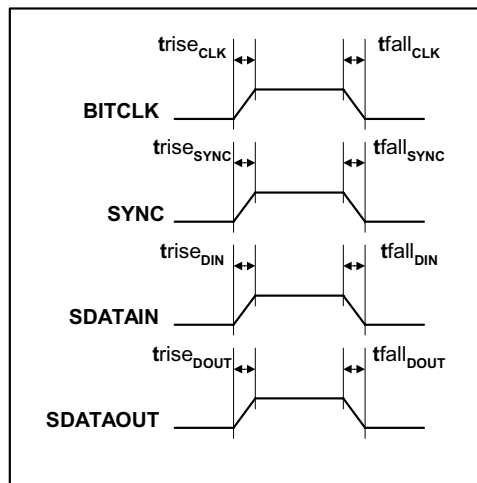

**Figure 9 Signal Rise and Fall Times (50pF External Load)**

PARAMETER	SYMBOL	MIN	TYP	MAX	UNIT
BITCLK rise time	$trise_{CLK}$	2		6	ns
BITCLK fall time	$tfall_{CLK}$	2		6	ns
SYNC rise time	$trise_{SYNC}$	2		6	ns
SYNC fall time	$tfall_{SYNC}$	2		6	ns
SDATAIN rise time	$trise_{DIN}$	2		6	ns
SDATAIN fall time	$tfall_{DIN}$	2		6	ns
SDATAOUT rise time	$trise_{DOUT}$	2		6	ns
SDATAOUT fall time	$tfall_{DOUT}$	2		6	ns

## DEVICE DESCRIPTION

### INTRODUCTION

This specification describes the WM9705 audio codec, which is designed to be software and hardware compatible with the Intel AC'97 rev2.2 component specification. The device is a derivative of the basic AC'97 codec, with added support for resistive touch-screen pen inputs. Variable Rate Audio (VRA) is supported at rates defined in the Intel rev2.1 or rev2.2 specification, and a SPDIF output port is provided which may optionally be used to output the PCM DAC information to external processors. A key feature of operation of the pen digitiser function is the cessation of screen drive activity when the pen is lifted from the screen, so minimising audio performance degradation and reducing power consumption.

WM9705 offers the following features:

Stereo Audio Codec with Intel specified VRA support of different audio sample rates

Pen Digitiser function with 4-wire pen interface and support for pen-down detection, pen pressure measurement and wake-on-pen-down.

Auxiliary ADC inputs for temperature, supply and battery monitoring.

Pen-down flag and ADC BUSY flags, output to pins, and MASK input pin provided to allow delay of pen conversions in event of LCD activity

Optional SPDIF and I<sup>2</sup>S audio outputs (SPDIF output may be hardware enabled so needing no driver support)

Headphone drive capability and optional auto detection of headset or headphone plug in

It is highly recommended that the Intel AC'97 rev2.2 specification be studied in parallel with this document: This specification can be downloaded from the Intel web site.

The WM9705 is fully operable on 3V or 5V or mixed 3/5V supplies, and is packaged in the industry standard 48pin TQFP package with 7mm body size.

Figure 10 shows the functional block diagram including control register bit locations for WM9705.

### AC'97 FEATURES

WM9705 implements the base set of AC'97 rev2.2 features, plus several enhancements:

All rev2.2 specified variable audio sample rates supported

3-D stereo enhancement feature.

Headphone support on AUX outputs (pins 39,41)

Primary/secondary codec operation by pin programming of CID0 pin

SPDIF audio output with rev2.2 compliant control set.



## NON - AC'97 FEATURES

In addition to the AC'97 features offered, WM9705 also supports:

4-wire pen digitiser with integrated screen driver, featuring highly flexible modes of operation, supporting autonomous screen conversions, and auxiliary conversions. Screen X and Y connections driven from AUX and VID stereo input pins, which are still connected.

Headphone drive capability on MONO output, with extra signal routing switch PSEL, allowing PHONE input to be routed to MONO output

Extra switch HPND after the mixer allowing MIX without DAC signal to be output to headphone outputs, and so allowing DAC with no MIX to be output to LINE outputs.

I<sup>2</sup>S audio output capability, in addition to SPDIF output, allowing support of an extra external audio DAC for multi-channel solutions. SPDIF output may be hardware enabled.

Option to route the stereo audio ADC output to the SPDIF and/or I<sup>2</sup>S digital outputs

Auto-detect of headphones or headset plugged into the AUX headphone outputs, with internal routing of microphone signal from the headphone pin to the MIC1 input.

Battery monitoring input BMON that supports direct connection to battery voltages up to 6.5V.

MPM switch allowing mix of DAC + mixer output onto MONOUT and independent mix of DAC + PHONE and/or PCBEEP onto LINEOUT or HPOUT.

Reset powerdown override – holding MASK high in reset overrides the PR bits forcing the WM9705 into a low power mode

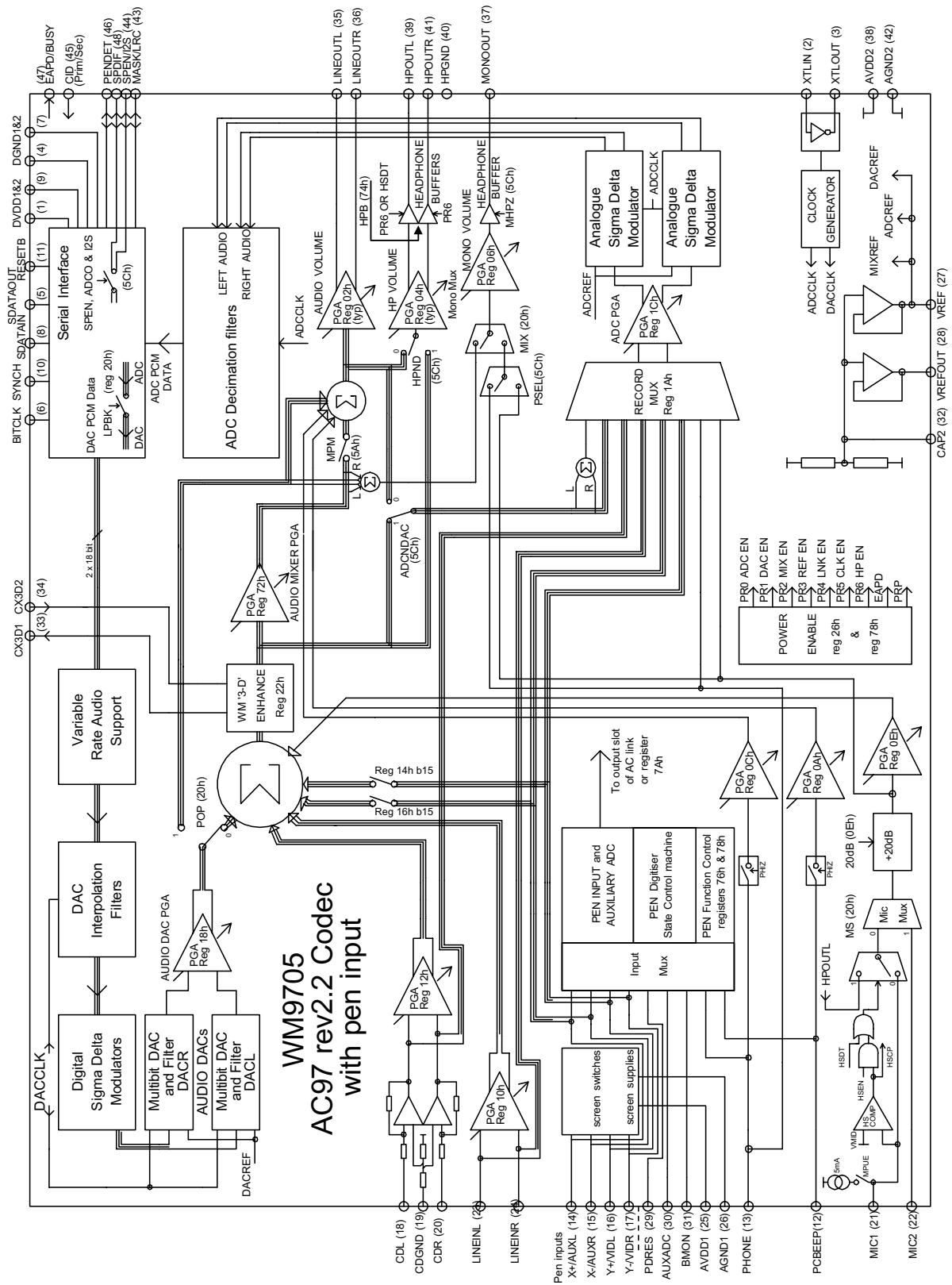

Figure 10 Functional Block Diagram

## PEN DIGITIZER AND AUXILIARY ADC

A 4 wire input pen digitiser function is included on WM9705. This circuit comprises driver circuits to drive typical resistive touch screens of the type used on PDA's, plus a 12 bit resolution ADC to convert pen input values. This ADC may also be used to perform additional auxiliary ADC conversions of the levels present on the AUXADC, BMON, PCBEEP or PHONE pins. A control bit (PHIZ in register 78h) is provided to allow PCBEEP and PHONE inputs to be made high impedance (internally disconnected so signal paths are cut) if required.

Operation of the pen digitiser function is controlled from digitiser control registers 76h and 78h. The ADC conversion result is obtained by reading from the contents of bits [11-0] in register 7Ah, or optionally by enabling the AC link SLOT transfer method, when results are sent back in the AC'97 slot data format. The pen digitiser ADC is a 12bit successive approximation type converter with excellent differential non-linearity performance.

The pen digitiser ADC may be used to convert either pen input data, or the voltages present on the AUXADC, BMON, PCBEEP or PHONE pins. Such functions as battery monitoring or temperature measurement might therefore be implemented.

The following pen digitiser features are available:

Support for wake-on-pen-down

Pen down detection, pressure measurement, auxiliary conversions

MASK conversion delay override or synchronous operation option

SLOT or R/W register data transfer

Programmable screen drive to sample taken delay

Programmable Pen-down detection threshold

Details of pen digitiser operation are available in the Pen Digitiser description section. Note that the pins allocated for X/Y screen connections are those that would normally be used for AUX and VID stereo inputs in a conventional AC '97 codec. In WM9705 these pins remain connected to the MIXER and ADC inputs, and may be used as analogue inputs, with the restriction that gain through the mixer input is fixed at 0dB. The normal MUTE function is provided using bit 15 in the appropriate register. It is recommended that these MUTE bits are left 'mute' whenever the screen is driven. Reading back the registers will report 0dB gain, and the MUTE value as programmed. ADC gain control on the AUX and VID inputs works as normal.

## 3-D STEREO ENHANCEMENT

This device contains a stereo enhancement circuit, designed to optimise the listening experience when the device is used in a typical PC operating environment. That is, with a pair of speakers placed either side of the monitor with little spatial separation. This circuit creates a difference signal by differencing left and right channel playback data, then filters this difference signal using lowpass and highpass filters whose time constants are set using external capacitors connected to the CX3D pins 33 and 34. Typically the values of 100nF and 47nF set highpass and lowpass poles at about 100Hz and 1kHz respectively. This frequency band corresponds to the range over which the ear is most sensitive to directional effects.

The filtered difference signal is gain adjusted by an amount set using the 4-bit value written to Register 22h bits 3 to 0. Value 0h is disable, value Fh is maximum effect. Typically a value of 8h is optimum. The user interface would most typically use a slider type of control to allow the user to adjust the level of enhancement to suit the program material. Bit D13 3D in Register 20h is the overall 3D enable bit. The Reset Register 00h reads back the value 11000 in bits D14 to D10. This corresponds to decimal 24, which is registered with Intel as Wolfson Stereo Enhancement.

Note that the external capacitors setting the filtering poles applied to the difference signal may be adjusted in value, or even replaced with a direct connection between the pins. If such adjustments are made, then the amount of difference signal fed back into the main signal paths may be significant, and can cause large signals which may limit, distort, or overdrive signal paths or speakers. Adjust these values with care, to select the preferred acoustic effect. There is no provision for pseudo-stereo effects. Mono signals will have no enhancement applied (if the signals are in phase and of the same amplitude). Signals from the PCM DAC channels can have stereo

enhancement applied. It can also be bypassed if desired. This function is enabled by setting the bit POP in Register 20h.

## VARIABLE SAMPLE RATE SUPPORT

The DACs and ADCs on this device support all the recommended sample rates specified in the Intel AC'97 rev2.1 and rev2.2 specifications for audio rates. The default rate is 48ks/s. If alternative rates are selected and variable rate audio is enabled (Register 2Ah, bit 0), the AC'97 interface continues to run at 48k words per second, but data is transferred across the link in bursts such that the net sample rate selected is achieved. It is up to the AC'97 Revision 2.1/2 compliant controller to ensure that data is supplied to the AC link, and received from the AC link, at the appropriate rate.

Variable rates are selected by writing to registers 2Ch (DAC) and 32h (ADC). ADC and DAC rates may be set independently, with left and right channels always at the same rate. Note that register 2Ch should only be written to when the DAC is powered ON, similarly register 32h should only be written to when the ADC is powered ON (see register 26h for power control). The device supports on demand sampling. That is, when the DAC signal processing circuits need another sample, a sample request is sent to the controller which must respond with a data sample in the next frame it sends. For example, if a rate of 24ks/s is selected, on average the device will request a sample from the controller every other frame, for each of the stereo DACs. Note that if an unsupported rate is written to one of the rate registers, the rate will default to the nearest rate supported. The Register will then respond, when interrogated, with the supported rate the device has defaulted to.

The WM9705 clocks will scale automatically dependent upon the MCLK frequency, where MCLK is not equal to 24.576MHz. With a 24MHz clock the BCLK frequency expected will be 12MHz and the sampling frequency (SYNCO expected is BCLK/256 = 46.875kHz.

AUDIO SAMPLE RATE	CONTROL VALUE D15-D0
8000	1F40
11025	2B11
16000	3E80
22050	5622
32000	7D000
44100	AC44
48000	BB80

Table 1 Variable Sample Rates Supported

## SPDIF OR I<sup>2</sup>S DIGITAL AUDIO DATA OUTPUT

The WM9705 SPDIF output may be enabled in hardware by holding pin 44 (SPEN) high when RESETB is taken high, or by writing to the SPDIF control bit in register 2Ah. If SPDIF pin 48 is pulled high at start-up by a weak pull-up (e.g. 100k), then SPDIF capability bit in register 28h is set to '0', i.e. no SPDIF capability. This allows for stuffing options, so that when SPDIF external components are not provided, the driver will see 'no SPDIF capability' and 'grey out' the relevant boxes in the control panel.

Additionally the digital audio may be output in I<sup>2</sup>S format using pin 44 (SPEN) as the data output, and outputting a frame clock or LRCLK onto pin 43. The data is clocked onto pin 44 using the regular BITCLK at 256fs, which would also then be used as the MCLK if the data is taken to an external DAC. Operation in this mode is selected by setting bit I<sup>2</sup>S in register 5Ch. A 64fs bitclk is also available and can be output on SPDIF by setting bit I2S64 in register 74h. Note that I<sup>2</sup>S operation is only supported for 48ks/s operation. Hardware selection of SPDIF operation by pulling pin SPEN 'hi' is compatible with I<sup>2</sup>S operation, provided a weak pull-up (circa 100k) was used to hold SPEN high at start-up. The SPEN pin becomes I<sup>2</sup>S data output pin when I<sup>2</sup>S is enabled, and the weak pull-up on this pin is overdriven.

For both SPDIF and I<sup>2</sup>S modes the data that is output may be sent from the WM9705 via the AC link in the same slots as normal DAC data or may be sent in different slots. The output slots that contain the SPDIF/I<sup>2</sup>S data are selected by bits SPSA[1:0] in register 2Ah. WM9705 is compliant with AC'97 rev2.2 specification with regard to slot mapping; therefore the default mode of operation is to output SPDIF or I<sup>2</sup>S data from the next data slots available after the audio data slots currently in use. Alternatively if required, data may be mapped from any of the available slots by selection using SPSA bits. The following table shows the default slot mapping for audio DACs and SPDIF/I<sup>2</sup>S data: (further details in the register description section later).

SPEN STATE AT START-UP	CODEC ID (PIN 45 STRAPPING)	AUDIO DAC SLOT DEFAULT	SPDIF OR I <sup>2</sup> S DATASLOT DEFAULT
'lo' (rev2.2 compliant)	'hi' = ID = 0 = primary	Slots 3 and 4 - front channels	Slots 7 and 8
'lo' (rev2.2 compliant)	'lo' = ID = 1 = secondary	Slots 7 and 8 – surround	Slots 6 and 9
'hi' (WM proprietary)	'hi' = ID = 0 = primary	Slots 3 and 4 - front channels	Slots 3 and 4
'hi' (WM proprietary)	'lo' = ID = 1 = secondary	Slots 7 and 8 – surround	Slots 3 and 4

**Table 2 DAC and SPDIF Slot Mapping Defaults**

However, an exception to the rev2.2 mapping table is made when SPDIF operation is enabled using the SPEN hardware enable pin (being held high at start-up): in this case SPDIF data is immediately output from the DAC primary slots 3 and 4. This allows for driver-less SPDIF operation, where the SPDIF or I<sup>2</sup>S output is simply the data contained in the main audio DAC channels. Channel status and control bits output along with the SPDIF data are as set in the SPDIF control register 3Ah. If required SPDIF data channel slot mapping may be then changed by setting SPSA bits as required. See tables 18, 19 and 20 for further details.

A mode is provided where the output from the ADC is sent out as the SPDIF or I<sup>2</sup>S data as above, rather than the data sent to the DACs over the AC link. This mode is enabled by setting bit ADCO in register 5Ch. ADC data continues to be sent via the AC link to the controller as normal.

WM9705 supports SPDIF and I<sup>2</sup>S data only at the default 48ks/s frame rate. Writing to SPSR bits in register 3Ah any value other than the default 48ks/s rate will result in a fail to write, with the 48ks/s value being returned on subsequent reads of these values.

## PRIMARY/SECONDARY ID SUPPORT

WM9705 supports operation as either a primary or a secondary codec. Configuration of the device as either a primary or as a secondary, is selected by tying the CID0 pin 45 on the package. Fundamentally, a device identified as a primary (ID = 0, CID0 = 'hi') produces BITCLK as an output, whereas a secondary (any other ID) must be provided with BITCLK as an input. This has the obvious implication that if the primary device on an AC link is disabled, the secondary devices cannot function. The AC'97 Revision 2.2 specification defines that the CID0 pin has inverting sense, and are provided with internal weak pull ups. Therefore, if no connections are made to the CID0 pin, then the pin pull hi and an ID = 0 is selected, i.e. primary. External connect to ground (with pull-down from 0 to 10k $\Omega$ ) will select codec ID = '1'.

PIN 45 CID0	ID SELECTED	PRIMARY OR SECONDARY	BITCLK
NC or pull-up	0	Primary	Output
Ground	1	Secondary	Input

**Table 3 Codec ID Selection**

## HEADPHONE DRIVE AND HEADSET AUTODETECT

Headphone drive capability is provided on the HPOUT output pins 39 and 41 (called AUXOUT in AC'97 rev2.2 specification) and also on the MONOOUT output pin 37.

Headphones of impedance typically from 16 $\Omega$  upwards may be connected to these pins. AC coupling with an appropriately sized capacitor is recommended for removal of the mid-rail DC pedestal present on these outputs. AC'97 rev2.2 specification recommends 32 $\Omega$  headphones; if a headphone is connected for use as a headset, where the stereo ear-pieces are driven in parallel, then each capsule must be of minimum 32 $\Omega$  impedance.

In many applications it is desirable to be able to connect either a stereo headphone to the headphone output pins, or a mono headset, comprising ear-piece(s) and a microphone. The microphone signal is sent via the tip connected wire of the typical 3-wire jack. In this event it is desirable to be able to auto-detect the connection of either the headphone or the headset (with microphone). The main characteristic of the headset and microphone compared to the headphone is that the microphone impedance is typically much higher than the headphone capsule (assuming a typical moving coil headphone). Because of this it is possible to connect a weak pull-up to the tip connection of the headphone jack.

When a headphone is connected the low impedance to ground of the headset pulls down the DC level to near ground. If a headset with microphone is plugged in, the high impedance of the microphone does not pull down the DC level on the tip connection, the DC on this pin now rising to near positive supply. This change in DC level is detected, so allowing detection of change from headphone to microphone, (or nothing plugged in of course). When this event is detected, the headphone amplifier that drives the tip connection is turned off, and the signal on this pin is routed instead to the MIC1 input as a microphone input.

This auto-detect comparator is enabled by setting bit HSCMP. The pull-up current is enabled by setting bit MPUEN in register 5Ch and also toggles the interrupt signal on the PENDET pin. When bit HSDT is set the mic1 input is connected to a comparator with a threshold set at mid-rail. When the comparator output is low, then the headphone driver is enabled. When the comparator output goes high (that is the pull-up current multiplied by the external impedance to ground on the mic1 pin is greater than mid-rail), the headphone amplifier is turned off and the mic1 signal is taken internally from the headphone output pin (39).

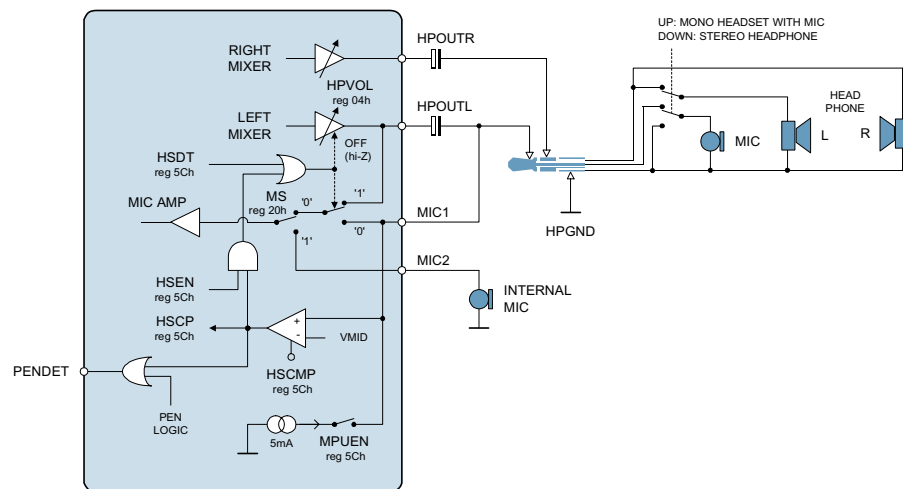

**Figure 10 Headset Autodetect**

Figure 10 shows this function schematically. The output signal from the comparator is accessible by reading bit HSCP in register 5Ch. Auto detect may be used by setting HSEN bit, or external control by using the HSDT bit which is an over-ride that forces the headset tri-state and microphone path switching function to occur.

This function would allow, for example, a stereo headphone to be used that had a microphone in the connecting lead, and a switch. The switch changes the headphone into a mono headset with microphone connected via the tip connection on the jack. If used in a product such as an MP3 capable phone it would allow the user to switch from headphone use to headset use by simply switching a single switch in the headphone cable, so at the same time answering or initiating telephone calls. It may also be possible to use the pull-up current to provide so called 'phantom power' to dynamic microphones with appropriate choice of microphone.

## DATA SLOT MAPPING

DAC data and SPDIF data sent to the device, ADC data sent from the device, can be optionally mapped into alternative slots under control of slot mapping bits located as follows:

SLOT MAPPING DATA TYPE	CONTROL BITS	REGISTER LOCATION
DAC data	DSA[1,0]	28h
SPDIF data	SPSA[1,0]	2Ah
ADC data	ASS[1,0]	5Ch (non-AC'97 feature)

Table 4 Data Slot Mapping Control

Default values and functional behavior are further described in the Serial Interface Register Map description. DAC slot mapping defaults are in Table 2.

## AC-LINK DIGITAL SERIAL INTERFACE PROTOCOL

A digital interface has been provided to control the WM9705 and transfer data to and from it. This serial interface is compatible with the Intel AC'97 specification.

The main control interface functions are:

- Control of analogue gain and signal paths through the mixer
- Bi-directional transfer of ADC and DAC words to and from AC'97 controller
- Selection of power-down modes
- Control of pen digitizer function
- Transfer of pen digitizer information and auxiliary conversion results from the codec

The WM9705 incorporates a 5-pin digital serial interface that links it to the AC'97 controller. AC-link is a bi-directional, fixed rate, serial PCM digital stream. It handles multiple input and output audio streams, as well as control register accesses employing a time division multiplexed (TDM) scheme. The AC-link architecture divides each audio frame into 12 outgoing and 12 incoming data streams, each with 20-bit sample resolution. With a minimum required DAC and ADC resolution of 16-bits, AC'97 may also be implemented with 18 or 20-bit DAC/ADC resolution, given the headroom that the AC-link architecture provides. The WM9705 provides support for 18-bit audio operation.

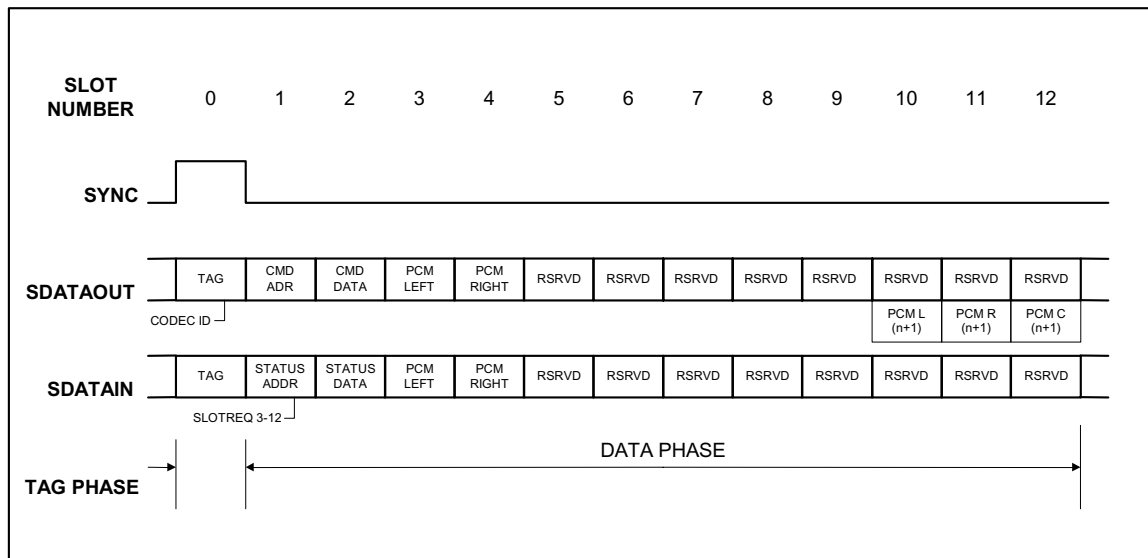

Figure 11 AC'97 Standard Bi-directional Audio Frame

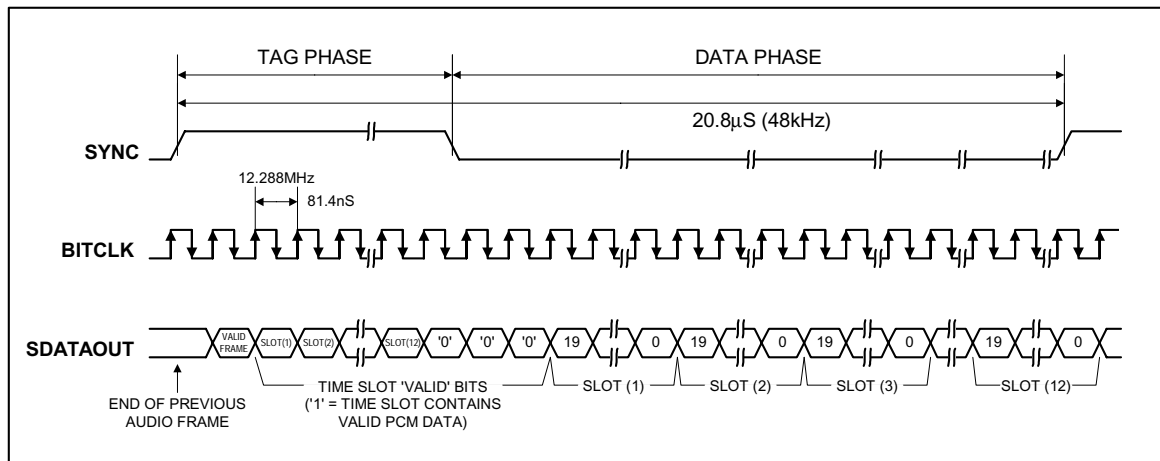

Figure 12 AC-link Audio Output Frame

The datastreams currently defined by the AC'97 specification include:

<b>PCM playback - 2 output slots</b>	2-channel composite PCM output stream
<b>PCM record data - 2 input slots</b>	2-channel composite PCM input stream
<b>Control - 2 output slots</b>	Control Register write port
<b>Status - 2 input slots</b>	Control Register read port
<b>Optional modem line codec output - 1 output slot</b>	Modem line codec DAC input stream
<b>Optional modem line codec input - 1 input slot</b>	Modem line codec ADC output stream
<b>Optional dedicated microphone input - 1 input slot</b>	Dedicated microphone input stream in support of stereo AEC and/or other voice applications.

Synchronisation of all AC-link data transactions is signalled by the WM9705 controller. The WM9705 drives the serial bit clock onto AC-link, which the AC'97 controller then qualifies with a synchronisation signal to construct audio frames.

SYNC, fixed at 48kHz, is derived by dividing down the serial clock (BITCLK). BITCLK, fixed at 12.288MHz, provides the necessary clocking granularity to support 12, 20-bit outgoing and incoming time slots. AC-link serial data is transitioned on each rising edge of BITCLK. The receiver of AC-link data, (WM9705 for outgoing data and AC'97 controller for incoming data), samples each serial bit on the falling edges of BITCLK.

The AC-link protocol provides for a special 16-bit time slot (slot 0) wherein each bit conveys a valid tag for its corresponding time slot within the current audio frame. A 1 in a given bit position of slot 0 indicates that the corresponding time slot within the current audio frame has been assigned to a data stream, and contains valid data. If a slot is tagged invalid, it is the responsibility of the source of the data, (the WM9705 for the input stream, AC'97 controller for the output stream), to stuff all bit positions with 0s during that slot's active time.

SYNC remains high for a total duration of 16 BITCLKs at the beginning of each audio frame.

The portion of the audio frame where SYNC is high is defined as the Tag Phase. The remainder of the audio frame where SYNC is low is defined as the Data Phase. Additionally, for power savings, all clock, sync, and data signals can be halted. This requires that the WM9705 be implemented as a static design to allow its Register contents to remain intact when entering a power savings mode.



## AC-LINK AUDIO OUTPUT FRAME (SDATAOUT)

The audio output frame data streams correspond to the multiplexed bundles of all digital output data targeting the WM9705's DAC inputs, and control registers. As briefly mentioned earlier, each audio output frame supports up to 12 20-bit outgoing data time slots. Slot 0 is a special reserved time slot containing 16-bits, which are used for AC-link protocol infrastructure.

Within slot 0 the first bit is a global bit (SDATAOUT slot 0, bit 15) which flags the validity for the entire audio frame. If the Valid Frame bit is a 1, this indicates that the current audio frame contains at least one time slot of valid data. The next 12-bit positions sampled by the WM9705 indicate which of the corresponding 12 time slots contain valid data.

In this way data streams of differing sample rates can be transmitted across AC-link at its fixed 48kHz audio frame rate. Figure 11 illustrates the time slot based AC-link protocol.

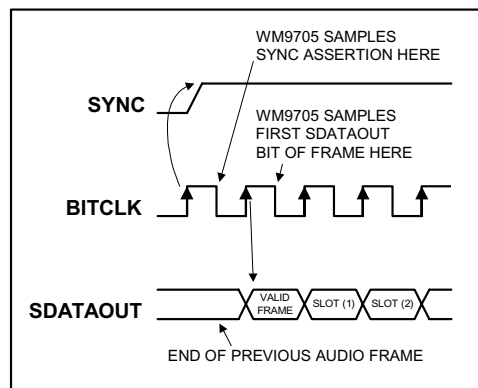

**Figure 13 Start of an Audio Output Frame**

A new audio output frame begins with a low to high transition of SYNC as shown in Figure 13. SYNC is synchronous to the rising edge of BITCLK. On the immediately following falling edge of BITCLK, the WM9705 samples the assertion of SYNC. This falling edge marks the time when both sides of AC-link are aware of the start of a new audio frame. On the next rising edge of BITCLK, AC'97 transitions SDATAOUT into the first bit position of slot 0 (Valid Frame bit). Each new bit position is presented to AC-link on a rising edge of BITCLK, and subsequently sampled by the WM9705 on the following falling edge of BITCLK. This sequence ensures that data transitions and subsequent sample points for both incoming and outgoing data streams are time aligned.

Baseline AC'97 specified audio functionality **MUST ALWAYS** sample rate convert to and from a fixed 48ks/s on the AC'97 controller. This requirement is necessary to ensure that interoperability between the AC'97 controller and the WM9705, among other things, can be guaranteed by definition for baseline specified AC'97 features.

SDATAOUT's composite stream is MSB justified (MSB first) with all non-valid slot bit positions stuffed with 0s by the AC'97 controller.

In the event that there are less than 20 valid bits within an assigned and valid time slot, the AC'97 controller always stuffs all trailing non-valid bit positions of the 20-bit slot with 0s.

As an example, consider an 8-bit sample stream that is being played out to one of the WM9705's DACs. The first 8 bit positions are presented to the DAC (MSB justified) followed by the next 12 bit positions, which are stuffed with 0s by the AC'97 controller. This ensures that regardless of the resolution of the implemented DAC (16, 18 or 20-bit), no DC biasing will be introduced by the least significant bits.

When mono audio sample streams are output from the AC'97 controller, it is necessary that **BOTH** left and right sample stream time slots be filled with the same data.

**SLOT 1: COMMAND ADDRESS PORT**

The command port is used to control features, and monitor status for the WM9705 functions including, but not limited to, mixer settings, and power management (refer to the Serial Interface Register Map). The control interface architecture supports up to 64, 16-bit read/write registers, addressable on even byte boundaries. Only the even Registers (00h, 02h, etc.) are valid, odd Register (01h, 03h, etc.) accesses are discouraged (if supported they should default to the preceding even byte boundary - i.e. a read to 01h will return the 16-bit contents of 00h). The WM9705's control register file is nonetheless readable as well as writeable to provide more robust testability.

Audio output frame slot 1 communicates control register address, and read/write command information to the WM9705.

**COMMAND ADDRESS PORT BIT ASSIGNMENTS**

Bit (19)	Read/write command (1 = read, 0 = write)
Bit (18:12)	Control register index (64 16-bit locations, addressed on even byte boundaries)
Bit (11:0)	Reserved (stuffed with 0s)

The first bit (MSB) sampled by the WM9705 indicates whether the current control transaction is a read or write operation. The following 7 bit positions communicate the targeted control register address. The trailing 12 bit positions within the slot are reserved and must be stuffed with 0s by the AC'97 controller.

**SLOT 2: COMMAND DATA PORT**

The command data port is used to deliver 16-bit control register write data in the event that the current command port operation is a write cycle. (As indicated by slot 1, bit 19).

Bit (19:4)	Control register write data (stuffed with 0s if current operation is a read)
Bit (3:0)	Reserved (stuffed with 0s)

If the current command port operation is a read then the entire time slot must be stuffed with 0s by the AC'97 controller.

**SLOT 3 AND 4: PCM PLAYBACK LEFT AND RIGHT CHANNELS**

Audio output frame slots 3 and 4 are the stereo digital audio left and right playback streams. In a typical Games Compatible PC this data is composed of standard PCM (.wav) output samples digitally mixed (on the AC'97 controller or host processor) with music synthesis output samples. If a sample stream of resolution less than 20-bits is transferred, the AC'97 controller must stuff all trailing non-valid bit positions within this time slot with 0s.

**SLOT 5: OPTIONAL MODEM LINE CODEC**

This data slot is not supported.

**SLOTS 6 AND 9: LFE AND CENTER CHANNEL DATA**

Data in these slots may be mapped onto the audio DACs or output as SPDIF/I<sup>2</sup>S data under control of the mapping bits DSA[1:0] in register 28h and SPSA[1:0] in register 2Ah.

**SLOTS 7 AND 8: SURROUND CHANNEL DATA**

Data in these slots may be mapped onto the audio DACs or output as SPDIF/I<sup>2</sup>S data under control of the mapping bits DSA in register 28h and SPSA in register 2Ah.

**SLOTS 10 AND 11:**

Data in these slots may be mapped onto the audio DACs or output as SPDIF/I<sup>2</sup>S data under control of the mapping bits DSA in register 28h and SPSA in register 2Ah.

**SLOT 12: GPIO**

Data in this slot is not supported.

AC-LINK AUDIO INPUT FRAME (SDATAIN)

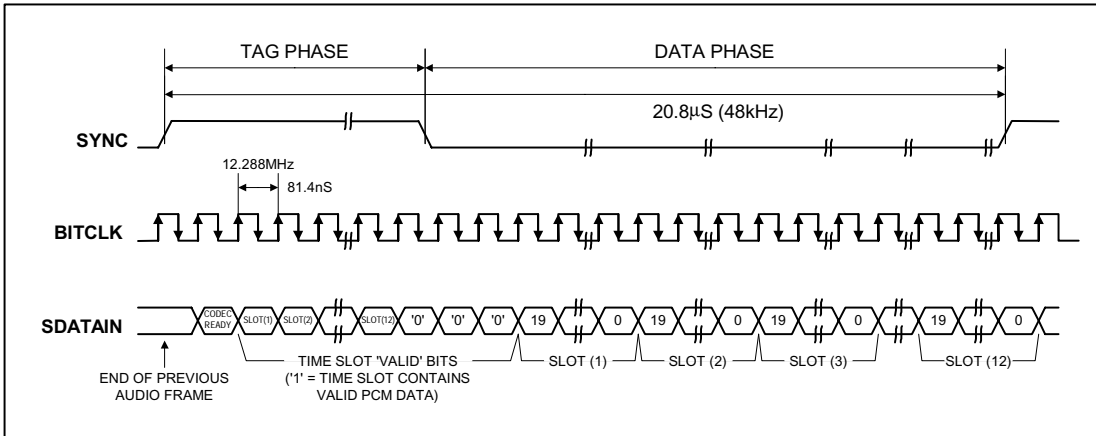

Figure 14 AC-link Audio Input Frame

The audio input frame data streams correspond to the multiplexed bundles of all digital input data targeting the AC'97 controller. As is the case for audio output frame, each AC-link audio input frame consists of 12, 20-bit time slots.

Slot 0 is a special reserved time slot containing 16-bits, which are used for AC-link protocol infrastructure.

Within slot 0 the first bit is a global bit (SDATAIN slot 0, bit 15) which flags whether the WM9705 is in the Codec Ready state or not. If the Codec Ready bit is a 0, this indicates that the WM9705 is not ready for normal operation. This condition is normal following the desertion of power on reset for example, while the WM9705's voltage references settle. When the AC-link Codec Ready indicator bit is a 1, it indicates that the AC-link and the WM9705 control and status registers are in a fully operational state. The AC'97 controller must further probe the Powerdown Control/Status Register to determine exactly which subsections, if any, are ready.

Prior to any attempts at putting the WM9705 into operation the AC'97 controller should poll the first bit in the audio input frame (SDATAIN slot 0, bit 15) for an indication that the WM9705 has gone Codec Ready.

Once the WM9705 is Codec Ready, then the next 12 bit positions sampled by the AC'97 controller indicate which of the corresponding 12 time slots are assigned to input data streams, and that they contain valid data. Figure 14 illustrates the time slot based AC-link protocol.

There are several subsections within the WM9705 that can independently go busy/ready. It is the responsibility of the WM9705 controller to probe more deeply into the WM9705 register file to determine which of the WM9705 subsections are actually ready.

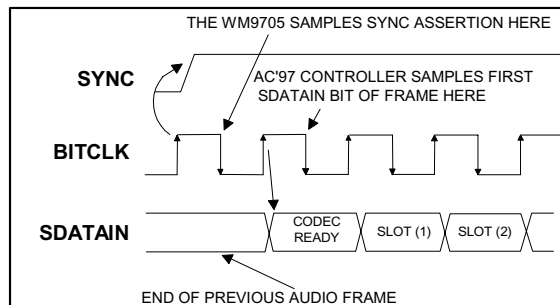

Figure 15 Start of an Audio Input Frame

A new audio input frame begins with a low to high transition of SYNC as shown in Figure 15. SYNC is synchronous to the rising edge of BITCLK. On the immediately following falling edge of BITCLK, the WM9705 samples the assertion of SYNC. This falling edge marks the time when both sides of AC-link are aware of the start of a new audio frame. On the next rising edge of BITCLK, the AC'97 controller transitions SDATAIN into the first bit position of slot 0 (valid frame bit). Each new bit position is presented to AC-link on a rising edge of BITCLK, and subsequently sampled by the AC'97 controller on the following falling edge of BITCLK. This sequence ensures that data transitions and subsequent sample points for both incoming and outgoing data streams are time aligned.

SDATAIN's composite stream is MSB justified (MSB first) with all non-valid bit positions (for assigned and/or unassigned time slots) stuffed with 0's by the WM9705. SDATAIN is sampled on the falling edges of BITCLK.

### SLOT 1: STATUS ADDRESS PORT

The status port is used to monitor status for the WM9705 functions including, but not limited to, mixer settings, and power management.

Audio input frame slot 1 echoes the control register index, for historical reference, for the data to be returned in slot 2. (Assuming that slots 1 and 2 had been tagged valid by the WM9705 during slot 0).

Bit (19)	RESERVED (stuffed with 0s)
Bit (18:12)	Control register index (echo of register index for which data is being returned)
Bit (11:2)	Variable Sample Rate SLOTREQ bits
Bit[1:0]	RESERVED (stuffed with 0s)

**Table 5 Status Address Port Bit Assignments**

The first bit (MSB) generated by the WM9705 is always stuffed with a 0. The following 7 bit positions communicate the associated control register address. The next 10 bits support the AC'97 Rev 2.2 variable sample rate signaling protocol and the trailing 2 bit positions are stuffed with 0s by the codec.

### SLOT 2: STATUS DATA PORT

The status data port delivers 16-bit control register read data.

Bit (19:4)	Control register read data (stuffed with 0s if tagged invalid by WM9705)
Bit (3:0)	RESERVED (stuffed with 0s)

**Table 6 Status Data Port Bit Assignments**

If slot 2 is tagged invalid by the WM9705, then the entire slot will be stuffed with 0s by the WM9705.

### SLOTS 3 AND 4: PCM RECORD LEFT AND RIGHT CHANNELS

Audio input frame slots 3 and 4 are the left and right channel outputs of the WM9705's audio ADC. Note that this data may alternatively be mapped onto slots 6 and 9, or 7 and 8 under control of the mapping bits ASS[1:0] in register 5Ch. The WM9705 sends out its ADC output data (MSB first), and stuffs any trailing non-valid bit positions with 0s to fill out its 20-bit time slot.

### SLOT 5: OPTIONAL MODEM LINE ADC

This slot is not supported by WM9705 in AC'97 compliant mode - this may be determined by the AC'97 controller interrogating the WM9705 Reset Register, 00h. However, Pen ADC data may be output in this slot, selected by SLT[2:0] in register 76h.

### SLOTS 6 AND 9:

These data slots may be utilised by the WM9705 to output audio data under control of the mapping bits ASS[1:0] in register 5Ch, allowing implementation of multi-channel systems. These slots may also be used to output Pen ADC data.

**SLOTS 7 AND 8:**

These data slots may be utilised by the WM9705 to output audio data under control of the mapping bits ASS [1:0] in register 5Ch, allowing implementation of multi-channel systems. These slots may also be used to output Pen ADC data.

**SLOTS 10 AND 11:**

These data slots may be utilised by the WM9705 to output audio data under control of the mapping bits ASS[1:0] in register 5Ch, allowing implementation of multi-channel systems. These slots may also be used to output Pen ADC data.

**SLOT 12:**

Pen digitiser data may be mapped onto this slot as MSB justified words, under control of register 76h. Alternatively pen input data can also be read from register 76h.

**AC-LINK LOW POWER MODE**

The AC-link signals can be placed in a low power mode. When the WM9705's Powerdown Register 26h, is programmed to the appropriate value, both BITCLK and SDATAIN will be brought to, and held at a logic low voltage level.

BITCLK and SDATAIN are transitioned low immediately following the decode of the write to the Powerdown Register (26h) with PR4. When the AC'97 controller driver is at the point where it is ready to program the AC-link into its low power mode, slots 1 and 2 are assumed to be the only valid stream in the audio output frame. At this point in time it is assumed that all sources of audio input have also been neutralised.

The AC'97 controller should also drive SYNC and SDATAOUT low after programming the WM9705 to this low power, halted mode.

Once the WM9705 has been instructed to halt BITCLK, a special wake up protocol must be used to bring the AC-link to the active mode since normal audio output and input frames can not be communicated in the absence of BITCLK.

In addition to the standard AC'97 wake-up protocol, the WM9705 also supports a wake-up after a pen-down status has been determined.

**WAKING UP THE AC-LINK**

There are 3 methods for bringing the AC-link out of a low power, halted mode.

AC-link protocol provides for a Cold WM9705 Reset, a Warm WM9705 Reset and a Pen Down Detect Warm Reset.

The current Powerdown state would ultimately dictate which form of WM9705 reset is appropriate. Unless a cold or register reset (a write to the Reset Register 00h) is performed, wherein the WM9705 registers are initialised to their default values, registers are required to keep state during all Powerdown modes.

Once powered down, re-activation of the AC-link via re-assertion of the SYNC signal must not occur for a minimum of 4 audio frame times following the frame in which the Powerdown was triggered. When AC-link powers up it indicates readiness via the Codec Ready bit (input slot 0, bit 15).

**COLD WM9705 RESET**

A cold reset is achieved by asserting RESETB for the minimum specified time. By driving RESETB low, BITCLK, and SDATAOUT will be activated, or re-activated as the case may be, and all the WM9705 control registers will be initialised to their default power on reset values.

RESETB is an asynchronous WM9705 input.

**WARM WM9705 RESET**

A warm WM9705 reset will re-activate the AC-link without altering the current WM9705 register values. A warm reset is signaled by driving SYNC high for a minimum of 1 $\mu$ s in the absence of BITCLK.

Within normal audio frames SYNC is synchronous to the WM9705 input. However, in the absence of BITCLK, SYNC is treated as an asynchronous input used in the generation of a warm reset to the WM9705. The WM9705 will not respond with the activation of BITCLK until SYNC has been sampled low again by the WM9705. This will preclude the false detection of a new audio frame.

#### PEN DOWN WM9705 WAKE-UP

If pen down is detected when the device is in low power halted mode with PRP[1:0] set to 01 and RPR set to 1, PR4 will be reset and the CODEC will transition SDATAIN from low to high to indicate a wakeup to the controller for it to restart the ACLINK. This wakeup mode is disabled when RPR is set.

#### POWER DOWN DURING WM9705 RESET – HARDWARE POWER DOWN MODE

Note that the normal default condition of WM9705 when RESETB is applied is 'all active'. However, if pin 43 MASK is pulled 'hi' during RESETB active, all PR bits are overridden and the device enters a low power mode. This allows a low power standby mode to be entered without writing to the device, a condition that is desirable for example, if batteries are changed in a PDA. The state of MASK is latched on the rising edge of RESETB and if MASK is 'hi' the device will remain in low power mode until register 26h is written to.

## SERIAL INTERFACE REGISTER MAP DESCRIPTION

(See Table 23)

The serial interface bits perform control functions described as follows: The register map is fully specified by the AC'97 specification, and this description is simply repeated below, with optional unsupported features omitted.

#### RESET REGISTER (INDEX 00h)

Writing any value to this register performs a register reset, which causes all registers to revert to their default values. Reading this register returns the ID code of the part, indication of modem support (not supported by the WM9705) and a code for the type of 3D stereo enhancement.

The ID decodes the capabilities of the WM9705 based on the following:

BIT	FUNCTION	VALUE ON WM9705
ID0	Dedicated Mic PCM in channel	0
ID1	Modem line codec support	0
ID2	Bass and treble control	0
ID3	Simulated stereo (mono to stereo)	0
ID4	Headphone out support	1
ID5	Loudness (bass boost) support	0
ID6	18-bit DAC resolution	1
ID7	20-bit DAC resolution	0
ID8	18-bit ADC resolution	1
ID9	20-bit ADC resolution	0
SE4...SE0	Wolfson Microelectronics 3D enhancement	11000

Table 7 Reset Register Function

Note that the WM9705 defaults to indicate 18-bit compatibility.

#### PLAY MASTER VOLUME REGISTERS (INDEX 02h, 04h AND 06h)

These registers manage the output signal volumes. Register 02h controls the stereo master volume (both right and left channels), Register 04h controls the stereo headphone out, and Register 06h controls the mono volume output. Each step corresponds to 1.5dB. The MSB of the register is the mute bit. When this bit is set to 1 the level for that channel is set at  $-\infty$ dB.

ML4 to ML0 is for left channel level, MR4 to MR0 is for the right channel and MM4 to MM0 is for the mono out channel.

Support for the MSB of the volume level is not provided by the WM9705. If the MSB is written to, then the WM9705 detects when that bit is set and sets all 4 LSBs to 1s. Example: If the driver writes a 1xxxx the WM9705 interprets that as x11111. It will also respond when read with x11111 rather than 1xxxx, the value written to it. The driver can use this feature to detect if support for the 6th bit is there or not.

The default value of both the mono and the stereo registers is 8000h (1000 0000 0000 0000), which corresponds to 0dB gain with mute on.

MUTE	MX4...MX0	FUNCTION
0	0 0000	0dB attenuation
0	0 0001	1.5dB attenuation
0	1 1111	46.5dB attenuation
1	x xxxx	$\infty$ dB attenuation

**Table 8 Volume Register Function**

The Headphone out has an additional 6dB boost, selectable by setting HPB in register 74h.

### PC BEEP REGISTER (INDEX 0Ah)

This controls the level for the PC-beep input. Each step corresponds to approximately 3dB of attenuation. The MSB of the register is the mute bit. When this bit is set to 1 the level for that channel is set at  $-\infty$ dB.

WM9705 defaults to the PC-beep path being muted, so an external speaker should be provided within the PC to alert the user to power on self-test problems.

MUTE	PV3...PV0	FUNCTION
0	0000	0dB attenuation
0	1111	45dB attenuation
1	xxxx	$\infty$ dB attenuation

**Table 9 PC-beep Register Function**

### ANALOGUE MIXER INPUT GAIN REGISTERS (INDEX 0Ch - 18h AND 72h)

This controls the gain/attenuation for each of the analogue inputs and mixer PGA. Each step corresponds to approximately 1.5dB. The MSB of the register is the mute bit. When this bit is set to 1 the level for that channel is set at  $-\infty$ dB. Note that the gain for the VID and AUX input channels is fixed at 0dB. Writes to the gain control bits for these channels are ignored, and the value of readback for these registers is always the default, with the exception of the mute bit 15 which may be written to and read from.

The default value for the mono registers is 8008h, which corresponds to 0dB gain with mute on. The default value for stereo registers is 8808h, which corresponds to 0dB gain with mute on.

MUTE	GX4...GX0	FUNCTION
0	00000	+12dB gain
0	01000	0dB gain
0	11111	-34.5dB gain
1	xxxxx	$-\infty$ dB gain

**Table 10 Mixer Gain Control Register Function**

### REGISTER 0Eh (MIC VOLUME REGISTER)

This has an extra bit that is for a 20dB boost. When bit 6 is set to 1 the 20dB boost is on. The default value is 8008h, which corresponds to 0dB gain with mute on.

### RECORD SELECT CONTROL REGISTER (INDEX 1Ah)

Used to select the record source independently for right and left (see Table 11). The default value is 0000h, which corresponds to Mic in. Setting Bit ADCNDAC in Register 5Ch selects a stereo mix WITHOUT DAC when (5 x 2 – 5 x 0) is 5.

SR2 TO SR0	RIGHT RECORD SOURCE	SL2 TO SL0	LEFT RECORD SOURCE
0	Mic	0	Mic
1	CD in (R)	1	CD in (L)
2	Video in (R)	2	Video in (L)
3	Aux in (R)	3	Aux in (L)
4	Line in (R)	4	Line in (L)
5	Stereo mix (R)	5	Stereo mix (L)
6	Mono mix	6	Mono mix
7	Phone	7	Phone

Table 11 Record Select Register Function

### RECORD GAIN REGISTERS (INDEX 1Ch)

1Ch sets the stereo input record gain with each step corresponding to 1.5dB. The MSB of the register is the mute bit. When this bit is set to 1, the level for both channels is set at  $-\infty$ dB.

The default value is 8000h, which corresponds to 0dB gain with mute on.

MUTE	GX3...GX0	FUNCTION
0	1111	+22.5dB gain
0	0000	0dB gain
1	xxxxx	$-\infty$ dB gain

Table 12 Record Gain Register Function

### GENERAL PURPOSE REGISTER (INDEX 20h)

This register is used to control several miscellaneous functions of the WM9705.

Below is a summary of each bit and its function. Only the POP, 3D, MIX, MS and LPBK bits are supported by the WM9705. The MS bit controls the Mic selector. The LPBK bit enables loopback of the ADC output to the DAC input without involving the AC-link, allowing for full system performance measurements. The function default value is 0000h which is all off.

BIT	FUNCTION
POP	PCM out path and mute, 0 = pre-3D, 1 = post-3D
3D	3D stereo enhancement on/off, 1 = on
MIX	Mono output select 0 = Mix, 1 = Mic
MS	Mic select 0 = Mic1, 1 = Mic2
LPBK	ADC/DAC loopback mode

### 3D CONTROL REGISTER (INDEX 22h)

This register is used to control the centre and/or depth of the 3D stereo enhancement function built into the AC'97 component. Only the depth bits DP0 to 3 have effect in the WM9705.

DP3...DP0	DEPTH
0	0%
1	
-	
8	Typical value
-	
15	100%

Table 13 3D Control Register

### POWERDOWN CONTROL/STATUS REGISTER (INDEX 26h)

This read/write register is used to program power-down states and monitor subsystem readiness. The lower half of this register is read only status, a 1 indicating that the subsection is ready. Ready is defined as the subsection able to perform in its nominal state. When this register is written the bit values that come in on AC-link will have no effect on read bits 0- 7.



When the AC-link Codec Ready indicator bit (SDATAIN slot 0, bit 15) is a 1 it indicates that the AC-link and the WM9705 control and status registers are in a fully operational state. The AC'97 controller must further probe this Powerdown Control/Status Register to determine exactly which subsections, if any, are ready.

Note that the normal default condition of WM9705 when RESETB is applied is 'all active'. However, if pin MASK is pulled 'hi' during RESETB active, all PR bits are overridden and the device enters a low power mode. This allows a low power standby mode to be entered without writing to the device, a condition that is desirable for example, if batteries are changed in a PDA. The state of the MASK pin is latched on the rising edge of RESETB and if MASK is 'hi' then the WM9705 will remain in low power mode until register 26h is written to.

READ BIT	FUNCTION
REF	VREFs up to nominal level
ANL	Analogue mixers, etc ready
DAC	DAC section ready to accept data
ADC	ADC section ready to transmit data

**Table 14 Powerdown Status Register Function**

The Powerdown modes are as follows. The first three bits are to be used individually rather than in combination with each other. The last bit PR3 can be used in combination with PR2 or by itself. PR0 and PR1 control the PCM ADCs and DACs only. PR6 powers down just the stereo Line Level output headphone amps on pins 39/41.

The WM9705 also includes a low power DAC to headphone mode, whereby resetting PR1 and PR6 enables the DAC and the path from the DAC to HPOUTL/R without having to power up the main mixer (PR2). The POP bit (reg 20h) also needs to be set for this mode. The headphone amplifier on the MONO output pin is not powered down by PR6, rather by PR2 or alternatively may be enabled by setting MONOEN in register 74h.

WRITE BIT	FUNCTION
PR0	PCM in ADCs and input Mux Powerdown
PR1	PCM out DACs Powerdown
PR2	Analogue mixer Powerdown (VREF still on)
PR3	Analogue mixer Powerdown (VREF off)
PR4	Digital interface (AC-link) Powerdown (external clock off)
PR5	Internal clock disable
PR6	HP amp Powerdown
EAPD	External amplifier Powerdown

**Table 15 Powerdown Control Register Function**

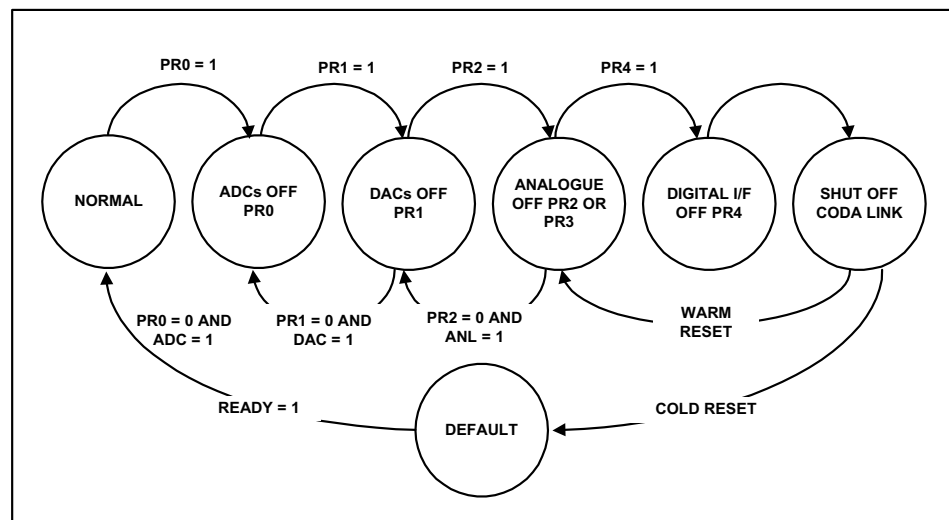

**Figure 16 An Example of the WM9705 Powerdown/Powerup Flow**

Figure 16 illustrates one example procedure to do a complete Powerdown of the WM9705. From normal operation sequential writes to the Powerdown Register are performed to Powerdown the WM9705 a piece at a time. After everything has been shut off (PR0 to PR3 set), a final write (of PR4) can be executed to shut down the WM9705's digital interface (AC-link).

The part will remain in sleep mode with all its registers holding their static values. To wake up the WM9705, the AC'97 controller will send a pulse on the sync line issuing a warm reset. This will restart the WM9705's digital interface (resetting PR4 to 0). The WM9705 can also be woken up with a cold reset. A cold reset will cause a loss of values of the registers, as a cold reset will set them to their default states. When a section is powered back on, the Powerdown Control/Status Register (index 26h) should be read to verify that the section is ready (i.e. stable) before attempting any operation that requires it.

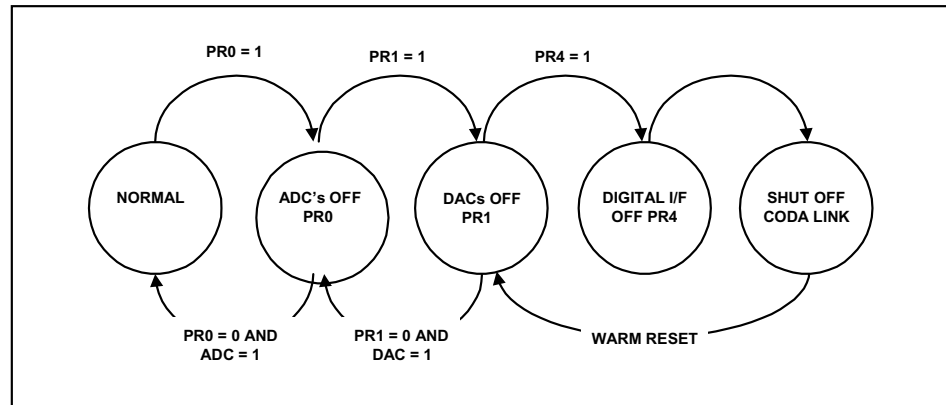

Figure 17 The WM9705 Powerdown Flow with Analogue Still Active

Figure 17 illustrates a state when all the mixers should work with the static volume settings that are contained in their associated registers. This is used when the user could be playing a CD (or external LINEIN source) through WM9705 to the speakers but have most of the system in low power mode. The procedure for this follows the previous except that the analogue mixer is never shut down.

The device can be used as a pen digitiser only, in order to set the WM9705 into this mode powerdown bits PR3 to 0, PR6 and EAPD should be set.

Note that in order to go into ultimate low power mode, PR4 and PR5 are required to be set which turns off the oscillator circuit. Asserting SYNC resets the PR4 and PR5 bit and re-starts the oscillator in the same way as the AC link is restarted.

## REGISTER 28h – EXTENDED AUDIO ID

The Extended Audio ID register is a read only register that identifies which extended audio features are supported (in addition to the original AC'97 features identified by reading the reset register at index 00h). A non zero value indicates the feature is supported.

DATA BIT	FUNCTION	VALUE
VRA	Variable rate audio support	1
DRA	Double rate audio support	0
SPDIF	SPDIF transmitter supported	'1' = supported
VRM	Variable rate Mic ADC support	0
DSA0	DAC slot mapping control	See table below
DSA1	DAC slot mapping control	See table below
CDAC	Centre DAC support	0
SDAC	Surround DAC support	0
LDAC	LFE DAC support	0
AMAP	Slot mapping support for Codec ID	1
REV0	Revision number	1
REV1	Revision number	0
ID0	Codec configuration – pin 45 value	0 (Inverse of level at pin 45)
ID1	Codec configuration – fixed in WM9705	0

Table 16 Extended Audio ID Register

DSA1, DSA0	DAC SLOT MAPPING
00	Slots 3 and 4
01	Slots 7 and 8
10	Slots 6 and 9
11	Slots 10 and 11

Table 17 DAC Slot Mapping

DAC slot mapping to slots 7 and 8 or slots 6 and 9 cannot be used in variable rate mode (VRA=1) for sample rates other than 48kHz.

## REGISTER 2AH – EXTENDED AUDIO STATUS AND CONTROL REGISTER

The Extended Audio Status and Control Register is a read/write register that provides status and control of the extended audio features. Note that SPDIF slot mapping default varies according to codec pin configuration. See Table 2.

DATA BIT	FUNCTION	READ/WRITE
VRA	Enables variable rate audio mode	Read/write
SPDIF	SPDIF transmitter enable	Read/write
SPSA0	SPDIF slot assignment	Read/write
SPSA1	SPDIF slot assignment	Read/write
SPCV	SPDIF validity bit	Read

Table 18 Extended Audio Status and Control Register

SPSA0, SPSA1	SPDIF SLOT MAPPING
00	Slots 3 and 4
01	Slots 7 and 8
10	Slots 6 and 9
11	Slots 10 and 11

Table 19 SPDIF Slot Mapping

## REGISTER 2Ch AND 32h – AUDIO SAMPLE RATE CONTROL REGISTERS

These registers are read/write registers that are written to, to select alternative sample rates for the audio PCM converters. Default is the 48ks/s rate. Note that only Revision 2.2 recommended rates are supported by the WM9705, selection of any other unsupported rates will cause the rate to default to the nearest supported rate, and the supported rate value to be latched and so read

back. Sample rate is entered in binary form to the appropriate register. Note sample rates should only be altered when the relevant DAC or ADC is powered ON.

## REGISTERS 3Ah – SPDIF CONTROL REGISTER

Register 3Ah is a read/write register that controls SPDIF functionality and manages bit fields propagated as channel status (or sub-frame in the V case). With the exception of V, this register should only be written to when the SPDIF transmitter is disabled (SPDIF bit in register 2Ah is '0'). Once the desired values have been written to this register, the contents should be read back to ensure that the sample rate in particular is supported, then SPDIF validity bit SPCV in register 2Ah should be read to ensure the desired configuration is valid. Only then should the SPDIF enable bit in register 2Ah be set. This ensures that control and status information start up correctly at the beginning of SPDIF transmission. WM9705 only supports an SPDIF sample rate of 48kHz.

CONTROL BIT	FUNCTION
PRO	Professional; '0' indicates consumer, '1' indicates professional
AUDIB	Non-audio; '0' indicates data is PCM, '1' indicates non-PCM format (eg DD or DTS)
COPY	Copyright; '0' indicates copyright is not asserted, '1' indicates copyright
PRE	Pre-emphasis; '0' indicates not pre-emphasis, '1' indicates 50/15us pre-emphasis
CC[6-0]	Category code; programmed as required by user
L	Generation level; programmed as required by user
V	Validity bit; '0' indicates frame valid, '1' indicates frame not valid

Table 20 SPDIF Control Register

## VENDOR SPECIFIC REGISTERS (INDEX 5Ah - 7Ah)

These registers are vendor specific. Do not write to these registers unless the Vendor ID register has been checked first to ensure that the controller knows the source of the AC '97 component.

### MIXER MUTE PATH (INDEX 5Ah)

Bit 4 (MPM) is used to disable the path between the main input mixer and the lineout mixer, see Figure 9. Setting this bit to 1, breaks the connection and allows the following combinations:

DAC + PHONE + PCBEEP to line out / headphone out

DAC + CD + LINE + AUX + VID + MIC to mono output

When writing to this register all bits (except MPM) must be written as a 0 or device function can not be guaranteed. Only the default value can be read from this register.

### VENDOR SPECIFIC MODE CONTROL (INDEX 5Ch)

Register 5Ch is a vendor specific control register used to control the function of non-AC'97 specified functions. This register defaults to all special features 'disabled' i.e. All zeros.

CONTROL BIT	FUNCTION
AMUTE	Indicates automute has been detected in the audio DAC (all '0' data) – read only
HSCP	Headset detect comparator output – read only
MPUEN	Mic pull up enable
MHPZ	Mono headphone tristate enable
PSEL	PHONE to MONO path switch enable
HSDT	Overrides Headset detect comparator, forcing left headphone amp to tristate
HSEN	Headset auto-detect enable
HPND	Headphone with no DAC enable
AMEN	Automute enable bit
I <sup>2</sup> S	I <sup>2</sup> S data output enable
ADCNDAC	ADC no DAC path enable
ADCO	ADC to SPDIF and/or I <sup>2</sup> S output
HPF	ADC high pass filter disable;
HSCMP	Headset comparator enable bit
ASS1	ADC slot map control
ASS0	ADC slot map control

**Table 21 Vendor Specific Control Register 5Ch**

AMUTE indicates automute state has been detected. This is a read-only bit. 1 = automute detected.

HSCP is a read only bit, indicating headset detected. It is the output from the headset autodetect comparator. 0 = headset detected.

MPUEN enables a 5mA (typ) pull up current on the MIC1 input pin, which when a headset microphone of high impedance is plugged in, causes the MIC1 pin to pull up to above Vmid, and be detected. 1 = enable.

MHPZ tristates the MONO headphone driver output buffer. 1 = tristate.

PSEL enables the switch from PHONE input to MONO output; see block diagram. 1 = enable.

HSEN enables headset auto-detect function. HSCMP enables the headset detect comparator. 1 = enable.

HSDT overrides the headset auto-detect comparator, forcing the left headphone output to tristate and the HPLOUTL pin to be used as a headset microphone input path to the mic1 preamplifier input. 1 = autodetect comparator override.

HPND enables the switch which outputs only the analog mixer output to the HPHONE outputs, without the DAC signal being summed in. See block diagram. 1 = enable.

AMEN enables the DAC automute function, which detects zero data on both dac channels and auto-mutes the outputs under this condition. 1 = enable.

Bit I<sup>2</sup>S enables I<sup>2</sup>S output, sending an LRCLK to the MASK/LRC pin (pin 43) and I<sup>2</sup>S data to the SPEN/I<sup>2</sup>S pin (pin 44). BITCLK is used to clock out the data. Only 48ks/s data is supported. 1 = enable.

ADCNDAC selects input to the ADC from before the point where the DAC signal is summed in. 1 = select.

Bit ADCO is used to select data from the internal ADCs to be output as SPDIF or I<sup>2</sup>S data on these pins rather than the data from the selected AC link slot. 1 = select.

HPF turns off the digital high pass filter in the ADC output when set to '1'.

ASS1, ASS0 are ADC slot mapping control bits. See table below. Default is slots 3 and 4.

ASS1, ASS0	ADC SLOT MAPPING ( L/R)
00	Slots 3 and 4
01	Slots 7 and 8
10	Slots 6 and 9
11	Slots 10 and 11

Table 22 ADC Slot Mapping Control

**VENDOR SPECIFIC GAIN CONTROL REGISTER (INDEX 72h)**

This register controls the gain and mute functions applied to the mixer path. This PGA is not accommodated in the Intel specification, but is required in order to allow the option of simultaneous recording of the mixer output and playback of DAC signals. The function is as for the other mixer PGA's. However, the default value of the register is not-muted. If it is not used it will be transparent to the user. Normally this register would be used in collaboration with bit ADCNDAC in register 5Ch, allowing recording of the analog mix, manipulation in the digital domain by an external DSP, then playback through the DACs on the WM9705.

**PEN DIGITIZER CONTROL REGISTERS (INDEX 76, 78h)**

These registers are used for pen digitiser control. See Pen Digitiser Operation section, for details of operation.

**PEN DIGITIZER DATA REGISTER (INDEX 7Ah)**

Register 7Ah is used to store the results of digitizer ADC conversions, both for pen inputs and for auxiliary input conversions. Results are downloaded to the controller by interrogating this register.

See Pen Digitiser Operation section for more details.

**VENDOR SPECIFIC ADDITIONAL FUNCTIONALITY (INDEX 74H)**

HPB boosts the headphone output by 6dB. 1 = 6dB boost enabled.

I2S64 enables a 64fs bitclk output on SPDIF for i<sup>2</sup>s data output. 1 = enabled.

MONOEN enables the mono output independently of PR2 (MIXER Powerdown). This allows the DAC to MONOUT path to be powered up by resetting PR1 and setting MONOEN while the Mixer is powered down (PR2 set), providing a lower power mode when the mixer function is not required.

**VENDOR ID REGISTERS (INDEX 7Ch AND 7Eh)**

These registers are for specific vendor identification if so desired. The ID method is Microsoft's Plug and Play Vendor ID code. The first character of that ID is F7 to F0, the second character S7 to S0, and the third T7 to T0. These three characters are ASCII encoded. The REV7 to REV0 field is for the Vendor Revision number. In the WM9705 the vendor ID is set to WML5.

Wolfson is a registered Microsoft Plug and Play vendor.

## SERIAL INTERFACE REGISTER MAP

The following table shows the function and address of the various control bits that are loaded and read through the serial interface.

Reg	Name	D15	D14	D13	D12	D11	D10	D9	D8	D7	D6	D5	D4	D3	D2	D1	D0	Default
00h	Reset	X	SE4	SE3	SE2	SE1	SE0	ID9	ID8	ID7	ID6	ID5	ID4	ID3	ID2	ID1	ID0	6150h
02h	Master volume	Mute	X	X	ML4	ML3	ML2	ML1	ML0	X	X	X	MR4	MR3	MR2	MR1	MR0	8000h
04h	HPHONE volume	Mute	X	X	ML4	ML3	ML2	ML1	ML0	X	X	X	MR4	MR3	MR2	MR1	MR0	8000h
06h	Master volume mono	Mute	X	X	X	X	X	X	X	X	X	X	MM4	MM3	MM2	MM1	MM0	8000h
0Ah	PCBEEP volume	Mute	X	X	X	X	X	X	X	X	X	X	PV3	PV2	PV2	PV0	X	8000h
0Ch	Phone volume	Mute	X	X	X	X	X	X	X	X	X	X	GN4	GN3	GN2	GN1	GN0	8008h
0Eh	Mic volume	Mute	X	X	X	X	X	X	X	X	20dB	X	GN4	GN3	GN2	GN1	GN0	8008h
10h	Line in volume	Mute	X	X	GL4	GL3	GL2	GL1	GL0	X	X	X	GR4	GR3	GR2	GR1	GR0	8808h
12h	CD volume	Mute	X	X	GL4	GL3	GL2	GL1	GL0	X	X	X	GR4	GR3	GR2	GR1	GR0	8808h
14h	Video volume	Mute	X	X	0	1	0	0	0	X	X	X	0	1	0	0	0	8808h
16h	Aux volume	Mute	X	X	0	1	0	0	0	X	X	X	0	1	0	0	0	8808h
18h	PCM out volume	Mute	X	X	GL4	GL3	GL2	GL1	GL0	X	X	X	GR4	GR3	GR2	GR1	GR0	8808h
1Ah	Rec select	X	X	X	X	X	SL2	SL1	SL0	X	X	X	X	X	SR2	SR1	SR0	0000h
1Ch	Rec gain	Mute	X	X	X	GL3	GL2	GL1	GL0	X	X	X	X	GR3	GR2	GR1	GR0	8000h
20h	General purpose	POP	X	3D	X	X	X	MIX	MS	LPBK	X	X	X	X	X	X	X	0000h
22h	3D control	X	X	X	X	X	X	X	X	X	X	X	X	DP3	DP2	DP1	DP0	0000h
26h	Power/down control status	APD	PR6	PR5	PR4	PR3	PR2	PR1	PR0	X	X	X	X	REF	ANL	DAC	ADC	000Fh
28h	Ext'd audio ID	ID1	ID0	X	X	REV1	REV0	AMAP	LDAC	SDAC	CDAC	DSA1	DSA0	VRM	SPDIF	DRA	VRA	0605h
2Ah	Ext'd audio stat/ctrl	X	X	X	X	X	SPCV	X	X	X	X	SPSA1	SPSA0	X	SPDIF	X	VRA	0000h
2Ch	Audio DAC rate	SR15	SR14	SR13	SR12	SR11	SR10	SR9	SR8	SR7	SR6	SR5	SR4	SR3	SR2	SR1	SR0	BB80h
32h	Audio ADC rate	SR15	SR14	SR13	SR12	SR11	SR10	SR9	SR8	SR7	SR6	SR5	SR4	SR3	SR2	SR1	SR0	BB80h
3Ah	SPDIF control	V	0	1	0	L	CC6	CC5	CC4	CC3	CC2	CC1	CC0	PRE	COPY	UDIB	PRO	2000h
5Ah	Mixer Path Mute	0	0	0	0	0	0	0	0	0	0	0	MPM	0	0	0	0	0000h
5Ch	Add. Function control	AMUTE	HSCP	PUEN	MHPZ	PSEL	HSEN	HSDT	HPND	AMEN	I <sup>2</sup> S	ADCN DAC	ADCO	HPF	HS CMP	ASS1	ASS0	0000h
72h	Front mixer volume	Mute	X	X	GL4	GL3	GL2	GL1	GL0	X	X	X	GR4	GR3	GR2	GR1	GR0	0808h
74h	Add. Function	X	X	X	X	X	X	X	X	X	X	X	X	HPB	I <sup>2</sup> S64	X	MONOEN	0000h
76h	Digitizer control	POLL	ADR2	ADR1	ADR0	COO	CTC	CR1	CR0	DEL3	DEL2	DEL1	DEL0	SLEN	SLT2	SLT1	SLT0	0006h
78h	Digitizer control	PRP1	PRP0	RPR	PDEN	PINV	BSEN	BINV	WAIT	PIL	PHIZ	MSK1	MSK0	PDD3	PDD2	PDD1	PDD0	0000h
7Ah	Pen Digitizer data	PNDN	ADR2	ADR1	ADR0	D11	D10	D9	D8	D7	D6	D5	D4	D3	D2	D1	D0	0000h
7Ch	Vendor ID1	F7	F6	F5	F4	F3	F2	F1	F0	S7	S6	S5	S4	S3	S2	S1	S0	574Dh
7Eh	Vendor ID2	T7	T6	T5	T4	T3	T2	T1	T0	Rev7	Rev6	Rev5	Rev4	Rev3	Rev2	Rev1	Rev0	4C05h

**Table 23 Serial Interface Register Map Description**

**Note:**

1. Default values of register 28h and 2Ah depend on whether the device is a primary or secondary, and whether SPDIF capability is enabled by pulling pin 44 SPEN high. The conditions shown are for a primary codec with SPDIF capability.
2. Register 5Ah is write only. When writing to this register all bits except MPM (bit 4) must be written as 0, otherwise device function can not be guaranteed.

## PEN DIGITISER OPERATION

The pen digitiser function comprises a 12 bit successive approximation ADC, with a multi-channel input multiplexor to select which signal to convert, and a switching matrix to control driving of signals to the resistive touchscreen plates. A finite state machine is provided in order to control and sequence conversion operations.

A pen-down detection scheme is provided to allow detection of when the pen is in contact with the screen. This allows for the touchscreen to only be driven whilst the pen is down, saving on unnecessary power consumption. This minimises any degradation in audio performance that may occur due to the significant currents that flow through the on-chip screen drive switches. Figure 18 shows symbolically these component elements and their connectivity.

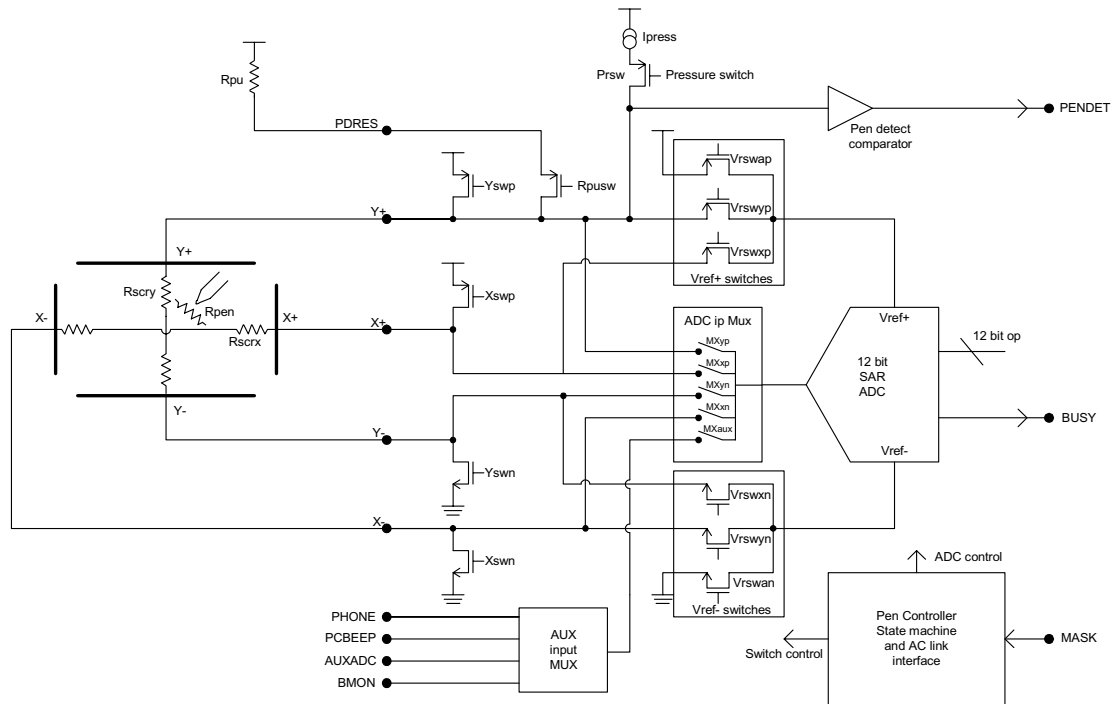

Figure 18 Pen Digitiser Block Diagram

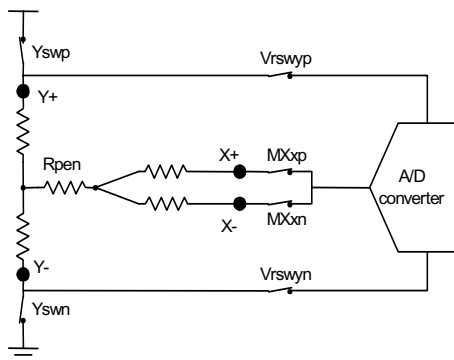

Figure 19 Y Position Conversion

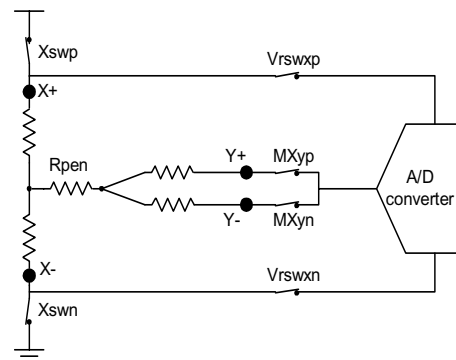

Figure 20 X Position Conversion



## TIMING OF PEN DIGITISER OPERATIONS

Timing of pen digitiser operations is linked to the AC link frame timing. A single ADC conversion takes one frame to complete, including taking a sample, converting it, and passing it into the register ready to be read back. This therefore allows a maximum conversion rate of 48ks/s, but in practise to allow time for screen plates to settle etc, much lower rates of conversion are anticipated.

The ADC is powered up only for the duration of each conversion, therefore power consumption is a linear function of the conversion rate chosen.

## CONTROL OF PEN DIGITISER FUNCTIONS

Control of the digitiser functions is via control bits written into control registers via the AC link. The following table shows the name, function and location of the control bits for the pen digitiser section of the WM9705. Address locations are chosen to avoid unexpected corruption of normal AC'97 audio codec operation, using mostly vendor specific addresses from the AC'97 address map.

Reg	Name	D15	D14	D13	D12	D11	D10	D9	D8	D7	D6	D5	D4	D3	D2	D1	D0	Default
76h	Digitizer control	POLL	ADR2	ADR1	ADR0	COO	CTC	CR1	CR0	DEL3	DEL2	DEL1	DEL0	SLEN	SLT2	SLT1	SLT0	0006h
78h	Digitizer control	PRP1	PRP0	RPR	PDEN	PINV	BSEN	BINV	WAIT	PIL	PHIZ	MSK1	MSK0	PDD3	PDD2	PDD1	PDD0	0000h
7Ah	Pen Digitizer data	PNDN	ADR2	ADR1	ADR0	D11	D10	D9	D8	D7	D6	D5	D4	D3	D2	D1	D0	0000h

### INDEX 76H – DIGITISER CONTROL WORD 1 – READ/WRITE REGISTER

BIT	LOCATION	FUNCTION
POLL	15	Starts a single polled conversion (resets itself at completion)
ADR[2-0]	14-12	Sets the address of the single conversion in polled mode, or extra conversions in Co-ordinate or Continuous mode. See Table 24.
COO	11	Selects a co-ordinate set of conversions
CTC	10	Starts continuous conversion operation
CR[1-0]	9,8	Sets continuous conversion rate
DEL[3-0]	7-4	Sets the delay between screen being driven and X or Y sample being taken
SLEN	3	Slot enable bit; allows conversion results to be output onto chosen slot
SLT[2-0]	2-0	Slot select bits; choose which slot to output data results in

**INDEX 78H – DIGITISER CONTROL WORD 2 – READ/WRITE REGISTER**

<b>BIT</b>	<b>LOCATION</b>	<b>FUNCTION</b>
PRP[1:0]	15:14	Pen digitiser power down bit control bits: 00 – Pen digitiser powered down, pen detect disabled, no wakeup on pen down (default) 01 – Pen digitiser powered off, pen detect enabled, wakeup on pen down enabled 10 – Pen digitiser powered off, pen detect enabled, no wakeup on pen down 11 – Pen digitiser powered up
RPR	13	Enables PR4 reset on pen down wake up
PDEN	12	causes conversions and screen drives to stop when pen is not down
PINV	11	Inverts sense of PENDET output: Default '0' causes PEN = 'down' to give a '1' output
BSEN	10	BUSY flag enable. Outputs converter BUSY signal on pin 47. '1' = converter busy, goes low at end of conversion to indicate result available
BINV	9	Invert sense of BUSY flag output
WAIT	8	WAIT bit; setting this bit causes conversion operations to halt when a result is about to be written to the data register 7Ah, if the last stored result has not yet been read. Conversions commence again once the result has been read
PIL	7	Pressure current select ('0'=200uA, '1'=400uA)
PHIZ	6	Sets PHONE and PCBEEP inputs to be High impedance by disconnecting them from mixer via an internal switch. Setting bit low opens the switch. Setting bit high closes the switch. Default setting is low.
MSK[1:0]	5:4	Selects what effect MASK input has: 00 = MASK pin ignored 01 = Mask pin is static; 'hi' halts conversions 10 = Mask pin is edge sensitive; rising or falling edge delays conversions by DEL [3-0] 11 = Mask pin becomes a synchronise input; conversions happen after edge
PDD[3:0]	3:0	Pen detect comparator threshold 0 to Vmid in 15 steps; 0h = use zero power comparator with Vmid threshold 1 = Vmid/15 threshold 15 = Vmid threshold

**INDEX 7AH – DIGITISER DATA WORD OUTPUT – READ REGISTER ONLY**

<b>BIT</b>	<b>LOCATION</b>	<b>FUNCTION</b>
PNDN	15	Indicates whether Pen is Down; '1' = 'Down'
ADR[2:0]	14:12	Conversion Address; Indicates which channel the following result is for
D[11:0]	11:0	ADC output result

**READBACK OF PEN DIGITISER RESULTS**

Readback of conversion results from either pen co-ordinate conversions, pressure measurements, or auxiliary conversion, is via the AC link interface.

Readback may be performed either by reading from the read only register 7Ah via the AC link, or by enabling SLOT mode (by writing SLEN = 1 in register 76h) where results are placed into the AC link data slots by WM9705, and sent back to the controller.

The readback word contains the 12 bit data in the lsb locations, plus a 3 bit header in the next 3 bit locations, whose value corresponds to the channel that the data was converted from. Other bits are padded with zero values. Channel addressing is the same as the address requested for the conversion, as follows:

ADR[2-0]	CHANNEL
000	none
001	X- plate
010	Y-plate
011	Pressure Conversion
100	BMON
101	AUXADC
110	PHONE
111	PCBEEP

**Table 24 Conversion Address to Channel Map**

If BUSY flag is enabled (BSEN bit in reg 78h set '1') then the BUSY pin will remain high until the conversion is complete, whereby it will transition low.

This signal is output onto pin 47, EAPD/BUSY where it may be observed by the controller if required as an interrupt. (Note that use of this BUSY flag clearly precludes use of the EAPD external amplifier power down bit, but as the WM9705 has integrated headphone amplifier with it's own power down bit PR6 in register 26h, this should not be a problem. If BSEN is not set, then EAPD operates as normal)

If SLOT method is enabled (SLEN bit in register 76h is set '1') then the data is output into the chosen slot and the appropriate slot tag bit set. Choice of which slot the data is written into is made by setting bits SLT[2-0] in register 76h. The following table shows which slot versus [2-0] value.

SLT[2-0]	OUTPUT SLOT FOR DIGITISER DATA
000	5
001	6
010	7
011	8
100	9
101	10
110	11

**Table 25 Pen ADC Slot Select**

When the conversion result has been read, then another conversion may be commenced as required. In the event of another conversion being requested, then the stored result from the last conversion will be overwritten when the new conversion has been completed.

However, if the WAIT bit is set in register 78h, then once a conversion is complete, the current conversion result may not be written into the results register, until the previous conversion result has been read. The sequence will halt at the finish of this current conversion, waiting for the results register to be cleared. Note that this does allow the controller to slow down the rate of conversions, so effectively determining the overall rate of conversion.

## CONVERSION CONTROL

Control of ADC conversions, and screen driving functions, is by one of three methods:

- Polling method
- Polled Co-ordinate method
- Continuous method

**POLLING METHOD**

The polling method relies on the controller to instruct every operation, i.e. to send an instruction requesting every individual conversion specifically. A polled conversion is requested by writing a 1 to POLL bit 15 in register 76h, along with the address of the channel to be converted.

The channel to convert is identified by a 3-bit tag word ADR[2-0] written to the Pen control register 76h. This tag has the same value as the value read back with the conversion result, thus identifying which channel the result is for, see Table 24. If ADD[2-0] is set to 0 then no conversion will take place and POLL will be reset.

If the channel to convert is an X or Y pen channel, then the appropriate screen driver switch configuration is selected first, the screen allowed to settle for a time (selected by programming the value into the DELAY register, DEL[3-0] in register 76h) and then the screen sample taken and the conversion made. Figures A2 and A3 show the switch configurations for X and Y plate conversions. Once the conversion is complete, the result is written into the results register 7Ah

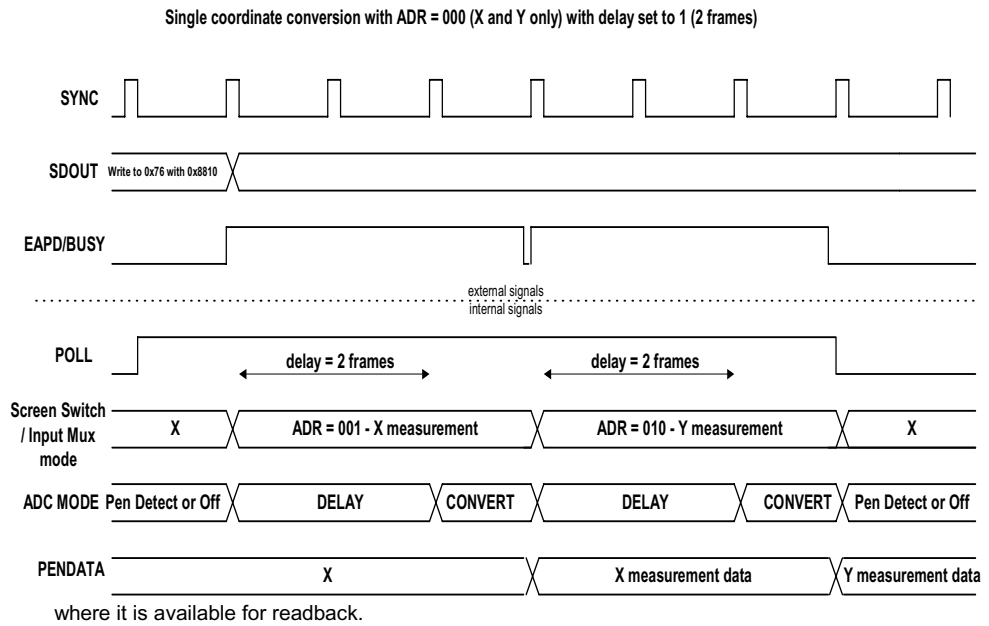

**Figure 21 Control of ADC conversions : Polling Method**

**CO-ORDINATE METHOD**

Setting bit COO in register 76h puts the device into Co-ordinate conversion mode.

Co-ordinate method of conversion instructs a sequence of conversions necessary to perform a pen co-ordinate determination. Most basically this requires an X and a Y conversion but may also include a pressure measurement. Writing to the POLL bit with COO bit in register 76h set initiates a set of co-ordinate conversions, the results of which are returned to the controller as soon as they are available.

If pressure conversion, or an auxiliary conversion are also required as part of the sequence, this is instructed by writing the appropriate address into the ADR [2-0] bits of register 76h. (X and Y addresses do not need to be set in this case, as they are implied by the choice of co-ordinate method of operation). DEL[3-0] delays are applied as for polled operation to all conversions. Subsequent POLL operations will then return both X and Y conversion results, plus the auxiliary or pressure conversion result indicated by the value set in ADR[2-0].

Once a conversion is complete, the result is written into the results register 7Ah where it is available for readback.

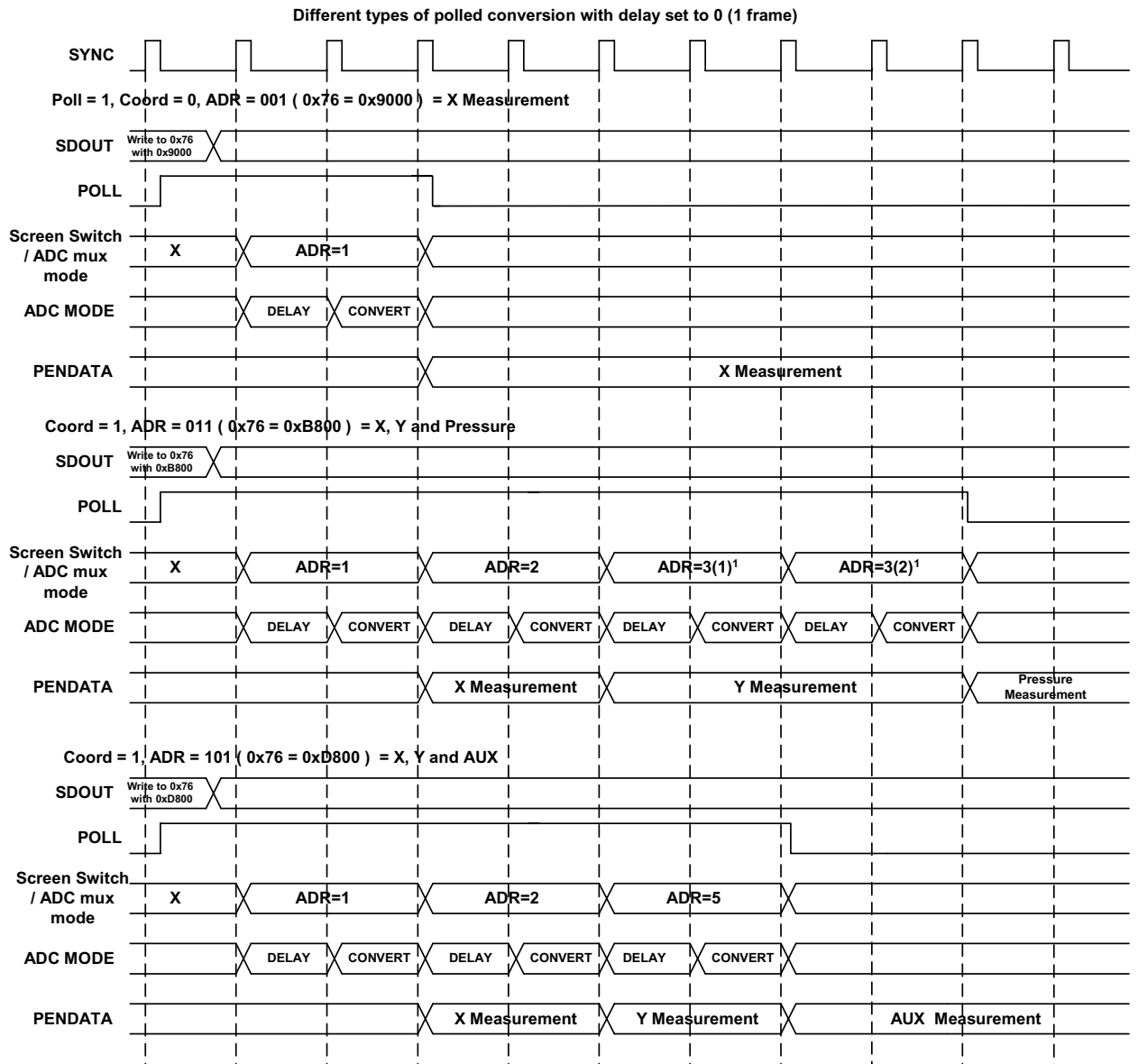

**Figure 22 Control of ADC Conversions : Polled Co-ordinate Method**

**Note:**

The pressure measurement is the difference between the voltage values measured between the resistive plates in the screen. As two values have to be obtained before the calculation can take place, two data acquisition cycles are required as illustrated above.

**CONTINUOUS METHOD**

The continuous method of conversion allows for an autonomous free running operation of the digitiser, converting pen X,Y results and either pressure or AUX channels continuously at a pre-set rate. This removes from the controller the overhead associated with instructing which conversion to do next etc. Continuous conversion is enabled by setting the CTC bit in register 76h. The rate of operation of the conversion sequence is set by writing bits CR0/1 into register 76h. These set the sequence rate as follows:

CR1	CR0	CONVERSION RATE
0	0	93.75Hz or 512 AC link frames
0	1	187.5Hz or 256 AC link frames
1	0	375Hz or 128 AC link frames
1	1	750Hz or 64 AC link frames

**Table 26 Conversion Rate**

Note that this rate is the MAXIMUM that may be obtained. In practice the rate will typically be slower, if the number of conversions to be performed, and the delay applied by the DEL[3-0] bits to each conversion, add up to a time greater than the nominal period for conversion set above. Likewise, if conversions are halted by pen going up, or MASK being applied, then this conversion rate will not be met. If MSK[1,0] is set to 11, then the conversion rate becomes synchronised to the rate of application of edges to the MASK input. The CR[1,0] value is ignored. Conversions are performed after the edge on the MASK pin, delayed by the value set in the DEL [3-0] register.

Normal operation will be to perform X,Y screen drives, and conversions, followed by a pressure or AUX conversion if requested by setting the appropriate address in the ADR[2-0] bits of register 76h. So long as the ADR[2-0] value remains set to auxiliary or pressure inputs, X,Y and the extra auxiliary conversions will be made in every cycle.

Pen-down detection is performed after completion of each set of conversions and the output sent to the PENDET pin, and output in bit 15 of the data read-back word. If the PDEN bit is left at the default value '0', if pen-down is not detected, then the continuous conversion process including driving the screen, will continue anyway. If the PDEN bit is set to '1', and a pen-down is NOT detected, then the conversion process will come to a stop, until the pen is once more returned to the screen. DEL[3-0] delays are applied as for polled operation to all conversions.

Once a conversion is complete, the result is written into the results register 7Ah where it is available for readback. Additionally the results may be output into a chosen SLOT by enabling slot readback bit SLEN in register 76h and selecting the desired slot by setting SLT[2-0].

Different types of continuous conversion with delay set to 0 (1 frames)

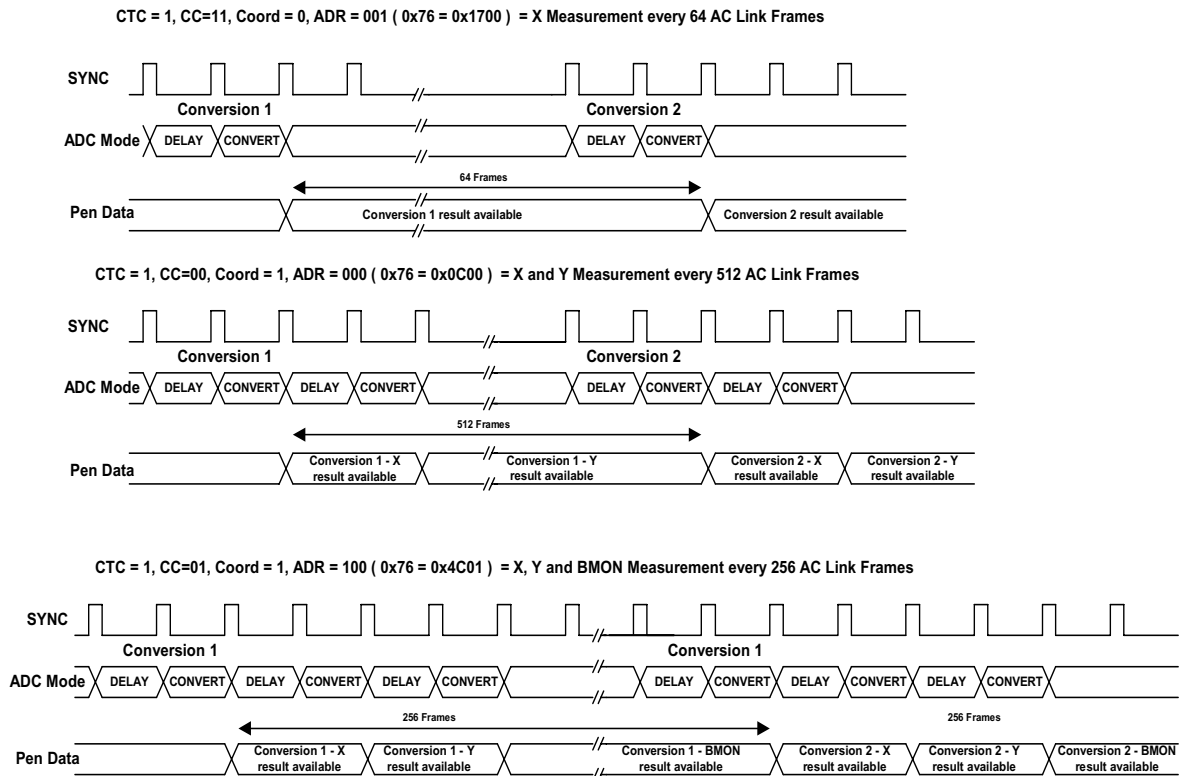

Figure 23 Control of ADC Conversions : Continuous Method

**DELAY FUNCTION**

In order to allow time for the plates to charge to a steady voltage when the screen drive switches are closed, a programmable delay may be applied which delays the sampling of the appropriate plate voltage by the ADC. This delay is at least one frame (1/48kHz) in duration, but may be increased by writing a value to the DEL[3-0] bits in register 76h. These set delays as follows:

DEL[3-0]	DELAY (FRAMES)	DELAY (uS)	DEL[3-0]	DELAY (FRAMES)	DELAY (uS)
0	1	20.8	8	96	1666
1	2	41.7	9	128	2000
2	4	83.3	10	160	2333
3	8	166.7	11	192	2666
4	16	333.3	12	224	3000
5	32	666.7	13	256	3333
6	48	1000	14	288	3666
7	64	1333	15	infinite	infinite

Table 27 Programmable Screen Drive Delay

Note that code 15 is used as a special mode, where the plates are driven permanently on, the switch matrix setting controlled by the value selected by ADR[2-0]. Thus the plates may be permanently set to drive X screen, Y screen, pressure configuration, or the auxiliary input channel permanently connected to the ADC input. For further information please see the section on Auxiliary Conversions.

## BUSY SIGNAL

The BUSY signal is derived from the pen state machine and is an indication of the AUXADC being active on a conversion cycle. When an AUXADC conversion is requested BUSY will go high 61 BCLKs after the rising edge of SYNC in the frame that the conversion was requested. BUSY will remain high until the data from the conversion is written into register 7A as the state machine sees the register write as the last stage of the conversion.

During a conversion that does not have the WAIT bit set, the BUSY negative pulse between conversions (signifying data written to Reg 7Ah) lasts 3 BCLKs and starts 11 BCLKs before the next rising SYNC edge. At the end of a conversion (or set of conversions) BUSY goes low 11 BCLKs before SYNC rises.

The WAIT bit instructs the device to wait until the previous conversion result has been read from register 7Ah before overwriting it. Without this bit set conversion results are not held. During a multiple conversion cycle in which WAIT is set the busy signal may operate differently. If the device is set to perform 3 simultaneous conversions with WAIT set the timing of busy is dependant on when the results are read from register 7A. If at the end of conversion 2 the result from conversion 1 has not been read from the register the conversion sequence can not complete. In this case BUSY will remain high until 61 BCLKs after the rising SYNC edge at the beginning of the frame in which register 7A was read. However if the result is read from register 7A before the end of conversion 2 the busy signal will operate as described in the paragraph above.

In the case of single conversions with WAIT set the operation of BUSY would be the same as that described above if the data was not read from Reg 7Ah before the next conversion requested had completed.

## PRESSURE MEASUREMENT

Pen pressure is implied by determining the resistance between the two plates.

Pressure measurements are sometimes used to determine whether the pen is in contact with the screen. However in this system the pen-down detect method is a far less power hungry way of determining whether the pen is 'down' as it does not require continuous driving of the screen and ADC conversions. This has the supplemental benefit of minimising audio signal interference. Pen pressure measurements may be made if required, perhaps for reasons other than simply determining pen-down.

This is done by injecting a known current into one end of one of the two plates (Y+), and grounding one end of the other plate (X-). Then the voltage at the other two plate terminals is converted (Y- and X+), the difference being a direct measure of the injected current value multiplied by the Pen contact resistance. Figure A4 shows this schematically.

Requesting a pressure measurement automatically initiates a pair of conversions, the difference in conversion values being returned as the pressure measurement. Delay between switching the appropriate screen and ADC mux switches, and performing the conversions, is set in the DEL[3-0] registers.

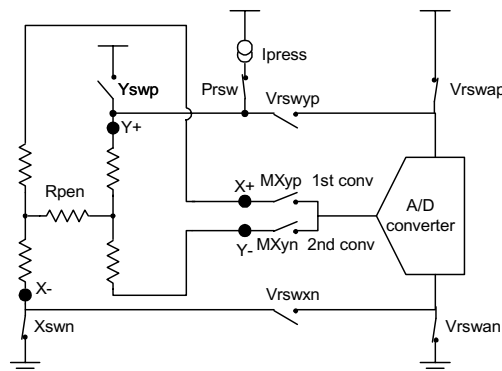

Figure 24 Pressure Measurement



## MASK FUNCTION

It is anticipated that sources of glitch noise such as LCD 'invert' signals will likely be picked up by the touchscreen plates and affect measurement accuracy. In order to minimise this effect, a signal may be applied to the MASK pin, which depending on the setting of the MSK[1-0] bits in register 78h, will delay the start of sampling of any input to the ADC. The behaviour of this delay is a function of the value set in the MSK[1-0] bits of register 78h and is described below:

MSK[1-0]	EFFECT OF SIGNAL ON MASK PIN
00	Mask has no effect on conversions
01	Static; 'hi' on MASK pin stops conversions, 'lo' has no effect.
10	Edge triggered; rising or falling edge on MASK pin delays conversions by an amount set in the DEL[3-0] register. Conversions are asynchronous to the MASK signal.
11	Synchronous mode; conversions wait until rising or falling edge on MASK initiates cycle; screen starts to be driven when the edge arrives, the conversion sample being taken a period set by DEL[3-0] after the edge.

**Table 28 Mask Control**

## PEN-DOWN DETECTION

Pen down detection is an important feature of the pen digitiser function; it allows screen driving and conversion operations to be suspended whilst the pen is not in contact with the screen so conserving power and minimising audio signal interference due to screen currents.

Pen down detection is performed by connecting an external or internal Pen Down Pull-up resistor (external resistor is connected between pin 29 and AVdd) to the Y+ terminal of the screen, grounding the X- terminal, and connecting the Y+ terminal to a comparator. This comparator has a threshold which lies midway between the ground and AVdd voltages. When the pen is applied to the screen, the resistance between the plates falls, pulling down the voltage on the Y plate and hence the Y+ terminal voltage. When this resistance falls enough, the comparator is triggered, so detecting that the 'pen is down'.

The threshold of this Pen detection function is set at about midrail. Varying the pressure on the pen, hence the pen resistance between the shorted plates, will cause the voltage on the pulled-up plate to vary. The value of the external pull up resistor may be selected, so allowing the sensitivity of the pen-down detect threshold to be adjusted. This allows the user more flexibility in tailoring the pen detect threshold to different screen types.

A 'zero power' comparator (effectively a gate) is used as the comparator, which has a fairly crudely set threshold, set at about mid supply. The output of this comparator is applied to the PENDET pin, and also into the finite state machine controlling the conversion and screen drive operations. Depending on the state of the PDEN bit in register 78h, this signal may be used to halt conversion operations whilst pen is 'up'. The PENDET pin can be active high or low depending on the state of PINV. The default state of PINV is a 0 which means PENDET is active high.

If the PDEN bit has not been set, then the state of the pen down detector output enables conversions and screen drives only when the pen is detected as 'down'. If PDEN bit is set, then conversions and screen drives will continue whether pen is detected as up or down. This allows, for example, for AUX channels to be converted whilst the pen is off the screen.

In order to provide more control over the sensitivity of the pen down detect threshold, an alternative active comparator circuit is provided, along with a 4 bit DAC which is used to adjust the comparator reference input voltage between near 0Volts and midrail. This allows lower pen resistance to be detected, without the need to use very low external pull-up resistor values which would otherwise be needed and which would consume large currents. When value 0h is written to the pen detect dac register bits PDD[3-0] in register 78h, this extra comparator is powered off and the zero power comparator used. When other values are written to this register, then the comparator is enabled, and thresholds from near 0V to midrail are set as below in Table 29.

PDD[3-0]	PEN DETECT THRESHOLD	PDD[3-0]	PEN DETECT THRESHOLD
0000	Use zero power comp.	1000	8Vmid/15
0001	Vmid/15	1001	9Vmid/15
0010	2Vmid/15	1010	10Vmid/15
0011	3Vmid/15	1011	11Vmid/15
0100	4Vmid/15	1100	12Vmid/15
0101	5Vmid/15	1101	13Vmid/15
0110	6Vmid/15	1110	14Vmid/15
0111	7Vmid/15	1111	Vmid

Table 29 Pen Detect Comparator Threshold

Figure 25 shows the pen detection function schematically.

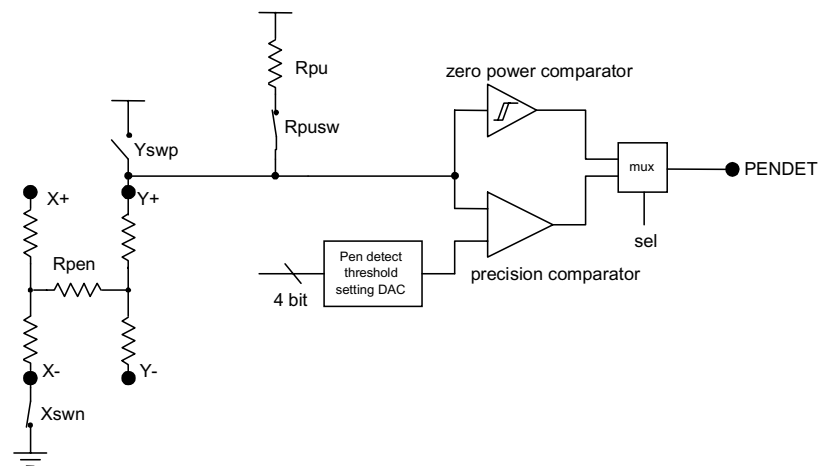

Figure 25 Pen Detection Configuration

## STANDBY OPERATION AND WAKE-UP

WM9705 allows for complete zero power standby operation, and wake-up-on-pen-down.

That is, all features of the device can be put into zero quiescent current standby, including the digital interfaces, and the device will wait consuming near zero power until it is re-awoken via pen down event or via activity on the AC link.

The AC link interface specification allows for standby operation, with all clocks stopped and the oscillator powered down, (all PR bits set). From this state, either the controller or the Codec can re-awaken the AC link. This feature is used by WM9705 to allow the standby operation, and wake on pen down function.

Once in standby, (all PR bits set and Pen digitiser power down control bits PRP[1:0] in reg 78h set to), the device awaits detection of pen down. Once this occurs, PRP[1] is set to active (1) and the pen digitiser wakes up, toggles the PENDET pin, and wakes the AC link by toggling the SDATAIN line. It is then up to the link controller how to respond. It will then toggle the SYNC signal, which causes the codec to wake up the AC link by re-setting PR4, waking the oscillator and starting to send BITCLKs. If RPR is set then pen down will also automatically reset PR4 and wake up the codec.

If the PRP[1:0] is set to 10, then the device is NOT woken on pen down detect, but the PENDET flag is toggled on pin 46 when the pen is detected as 'down'. The controller may then wake up the AC link and hence set PRP[1] bit if it so wishes.

Setting PRP[1:0] to 00 will power off the digitiser and pen down detection. PENDET will not toggle on pen down.

Provision of the PENDET flag as well as the AC link wake up procedure allows controllers that might not be full AC link compliant to still operate in this way, by monitoring the change in state of PENDET and using that signal as a wake-up flag.

## AUXILIARY CONVERSIONS

As previously described, auxiliary conversion may be performed by setting the ADR[2-0] address to the chosen input pin. Two completely dedicated input pins, AUXADC and BMON, and 2 shared inputs (PHONE, PCBEEP) may be selected as inputs to the ADC. The PHONE and PCBEEP inputs are normally still available as regular analogue inputs to the mixer path, and as such present a typical 100k input impedance (with respect to mid-rail). However, in the event that these analogue inputs are not required, and there is a need to use these inputs as high impedance auxiliary inputs, then setting bit 6, PHIZ, in register 78h disconnects the internal PHONE and PCBEEP paths, so making these inputs into high impedance ADC inputs only. The signal paths from PHONE or PCBEEP to the MIXER are disconnected in this mode.

Inputs to the AUXADC input should never exceed supply rails.

The ADC uses the AVDD1 and AGND1 supplies as its references, therefore conversions of AUXADC or BMON inputs are ratioed to these supplies; if they are inaccurate then the conversion may be inaccurate in absolute values.

If co-ordinate (COO set) or continuous (CTC set) conversion modes are chosen, then auxiliary conversions are performed amongst the cycle of screen drives and conversions.

In POLL (POLL set) mode, single auxiliary conversions may be performed. This cycle may be repeated to allow relatively high conversion rates to be applied to a single channel if required.

In this case, setting the DEL[3-0] value to 15, and the ADR[2-0] value to the required channel will permanently connect that channel input to the ADC input. In this way maximum cycle time for conversion may be achieved, by instructing POLL and reading the ADC result on alternate AC link frames. This gives a maximum conversion rate of 24k samples per second from 1 channel.

Alternatively continuous mode (CTC = '1') may be used to automatically generate conversion samples at the highest rate. The conversion rate control bits CTR[1-0] will limit this rate unless DEL[3-0] is set to 15. Then CTR[1-0] sets conversion rates of 1, 2, 4, 6 frames per sample. In this case up to one conversion is made per AC link frame, giving sample rates of 8, 12, 24 or 48ks/s. It is recommended that in this case the SLOT method of transferring data is used.

Inputs to the BMON battery monitoring input are allowed to be more positive than the AVdd supply rail, up to a maximum of 6.5Volts (total). This allows a battery of voltage greater than the AVdd supply to be monitored by the ADC without need for an external resistive divider. An internal divide by three consisting of a 20k and a 10k resistor in series, is switched onto the BMON pin whenever a conversion on this input is requested. Therefore current is consumed from the BMON input during the battery monitoring conversion process, but not at any other time. A series switch disconnects the divider from the negative internal supply when conversions are not being requested. Because of the internal divide by 3, inputs to the BMON pin are therefore converted with a digital output gain  $1/3^{\text{rd}}$  that of the other AUXADC input

The input impedance of the BMON input is 30k to ground WHEN the ADC is sampling, or hi-Z when it's not. When a BMON sample is requested the ADC samples the battery for a minimum of two frames. Inherent in this conversion is the delay state, set in register 7h bits 4-7 (DEL [3:0]), the lowest value of this delay is 0 which will introduce a delay of one frame, thus the minimum number of 2 frames for a conversion. If the BMON conversion is part of a set of conversions the delay state set for the series of conversions will be inherited by the BMON conversion. The minimum time the battery can see the 30k is 512 BCLKs or 41.6 us.

$$\text{Effective\_Input\_R} = \frac{\text{Number\_of\_frames\_between\_samples}}{2} \times 30000$$

In order to have an equivalent resistance of greater than 1MΩ the battery should be sampled no more than once every 67 frames.

RECOMMENDED EXTERNAL COMPONENTS

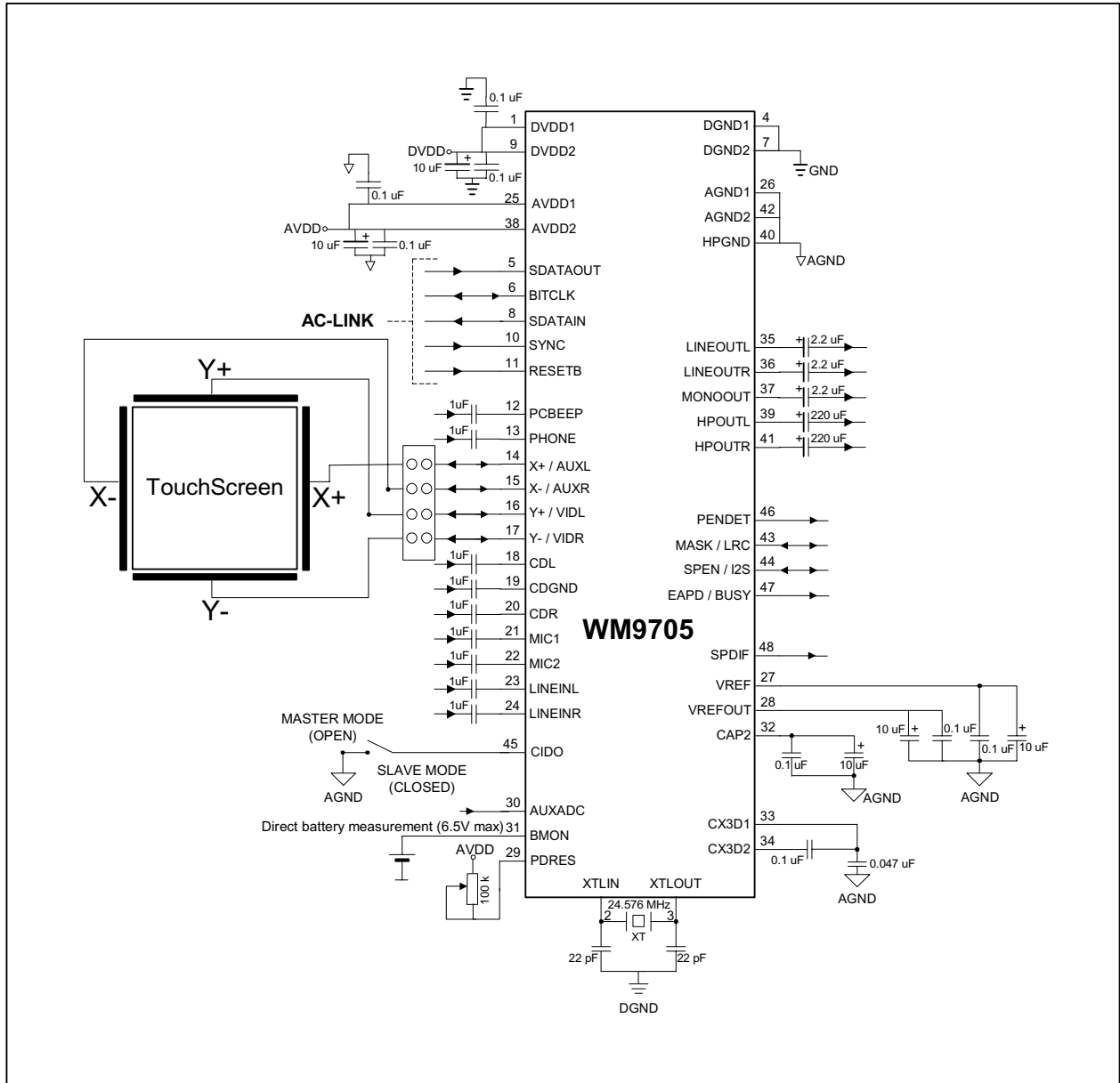
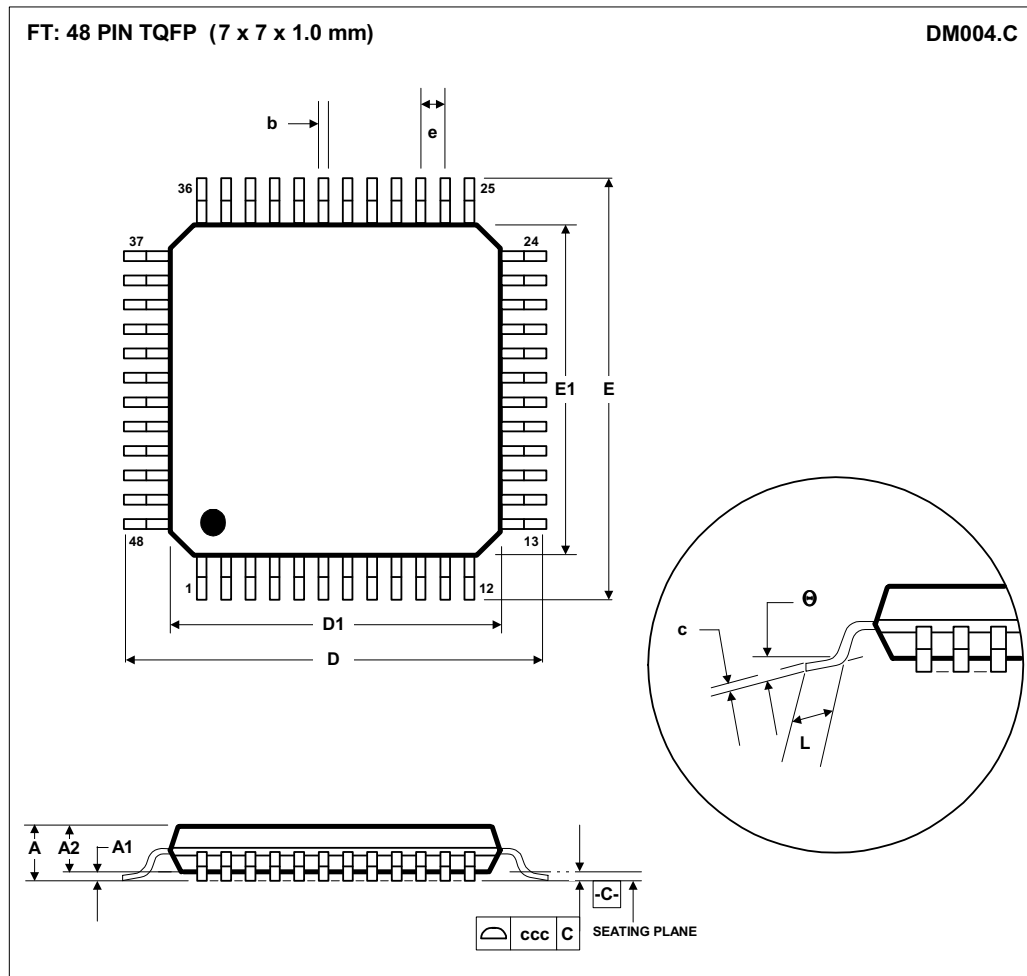

Figure 26 External Components Diagram

PACKAGE DIMENSIONS - TQFP



Symbols	Dimensions (mm)		
	MIN	NOM	MAX
<b>A</b>	-----	-----	1.20
<b>A<sub>1</sub></b>	0.05	-----	0.15
<b>A<sub>2</sub></b>	0.95	1.00	1.05
<b>b</b>	0.17	0.22	0.27
<b>c</b>	0.09	-----	0.20
<b>D</b>	9.00 BSC		
<b>D<sub>1</sub></b>	7.00 BSC		
<b>E</b>	9.00 BSC		
<b>E<sub>1</sub></b>	7.00 BSC		
<b>e</b>	0.50 BSC		
<b>L</b>	0.45	0.60	0.75
<b>theta</b>	0°	3.5°	7°
Tolerances of Form and Position			
<b>ccc</b>	0.08		
<b>REF:</b>	JEDEC.95, MS-026		

NOTES:  
 A. ALL LINEAR DIMENSIONS ARE IN MILLIMETERS.  
 B. THIS DRAWING IS SUBJECT TO CHANGE WITHOUT NOTICE.  
 C. BODY DIMENSIONS DO NOT INCLUDE MOLD FLASH OR PROTRUSION, NOT TO EXCEED 0.25MM.  
 D. MEETS JEDEC.95 MS-026, VARIATION = ABC. REFER TO THIS SPECIFICATION FOR FURTHER DETAILS.

PACKAGE DIMENSIONS - QFN

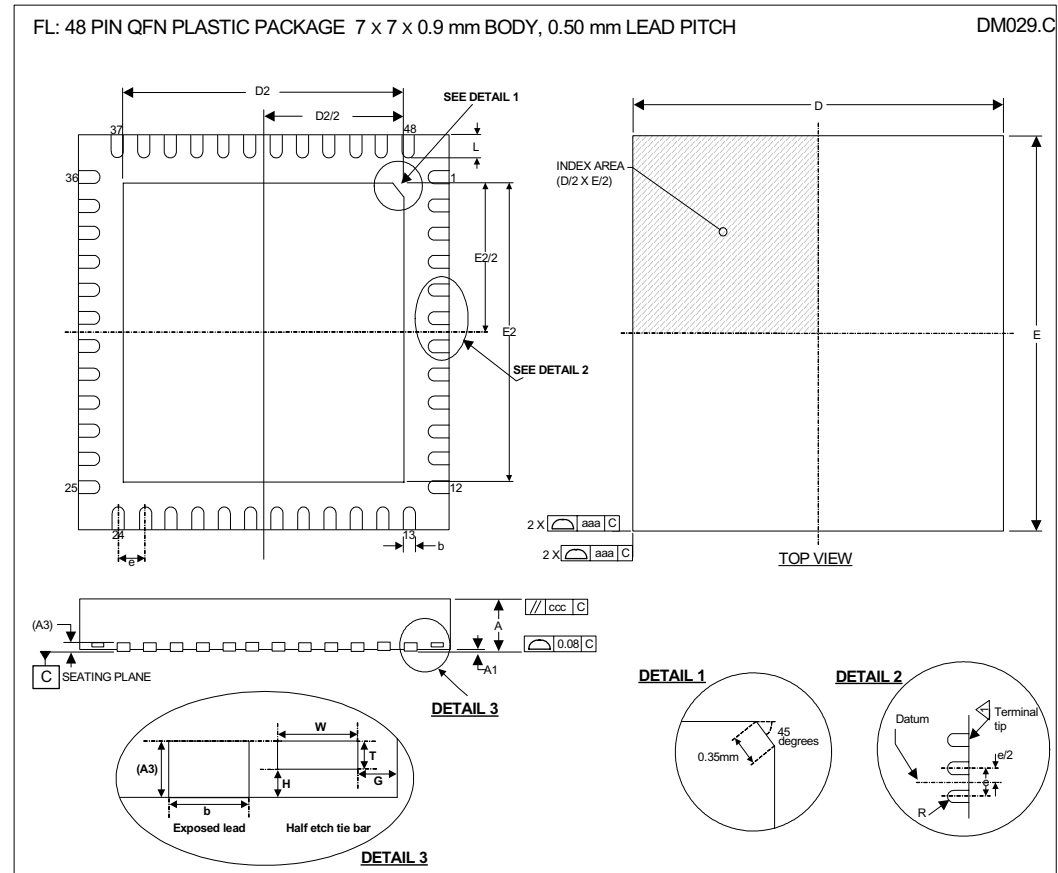

Symbols	Dimensions (mm)			NOTE
	MIN	NOM	MAX	
A	0.80	0.90	1.00	
A1	0	0.02	0.05	
A3		0.20 REF		
b	0.18	0.25	0.30	1
D		7.00 BSC		
D2	5.00	5.15	5.25	
E		7.00 BSC		
E2	5.00	5.15	5.25	
e		0.5 BSC		
G		0.213		
H		0.1		
L	0.30	0.4	0.50	
T		0.1		
W		0.2		
<b>Tolerances of Form and Position</b>				
aaa		0.15		
bbb		0.10		
ccc		0.10		
REF		JEDEC, MO-220, VARIATION VKKD-2		

- NOTES:
1. DIMENSION b APPLIED TO METALLIZED TERMINAL AND IS MEASURED BETWEEN 0.15 mm AND 0.30 mm FROM TERMINAL TIP.
  2. ALL DIMENSIONS ARE IN MILLIMETRES
  3. THE TERMINAL #1 IDENTIFIER AND TERMINAL NUMBERING CONVENTION SHALL CONFORM TO JESD 95-1 SPP-002.
  4. COPLANARITY APPLIES TO THE EXPOSED HEAT SINK SLUG AS WELL AS THE TERMINALS.
  5. THIS DRAWING IS SUBJECT TO CHANGE WITHOUT NOTICE.

## IMPORTANT NOTICE

Wolfson Microelectronics plc (WM) reserve the right to make changes to their products or to discontinue any product or service without notice, and advise customers to obtain the latest version of relevant information to verify, before placing orders, that information being relied on is current. All products are sold subject to the WM terms and conditions of sale supplied at the time of order acknowledgement, including those pertaining to warranty, patent infringement, and limitation of liability.

WM warrants performance of its products to the specifications applicable at the time of sale in accordance with WM's standard warranty. Testing and other quality control techniques are utilised to the extent WM deems necessary to support this warranty. Specific testing of all parameters of each device is not necessarily performed, except those mandated by government requirements.

In order to minimise risks associated with customer applications, adequate design and operating safeguards must be used by the customer to minimise inherent or procedural hazards. Wolfson products are not authorised for use as critical components in life support devices or systems without the express written approval of an officer of the company. Life support devices or systems are devices or systems that are intended for surgical implant into the body, or support or sustain life, and whose failure to perform when properly used in accordance with instructions for use provided, can be reasonably expected to result in a significant injury to the user. A critical component is any component of a life support device or system whose failure to perform can be reasonably expected to cause the failure of the life support device or system, or to affect its safety or effectiveness.

WM assumes no liability for applications assistance or customer product design. WM does not warrant or represent that any license, either express or implied, is granted under any patent right, copyright, mask work right, or other intellectual property right of WM covering or relating to any combination, machine, or process in which such products or services might be or are used. WM's publication of information regarding any third party's products or services does not constitute WM's approval, license, warranty or endorsement thereof.

Reproduction of information from the WM web site or datasheets is permissible only if reproduction is without alteration and is accompanied by all associated warranties, conditions, limitations and notices. Representation or reproduction of this information with alteration voids all warranties provided for an associated WM product or service, is an unfair and deceptive business practice, and WM is not responsible nor liable for any such use.

Resale of WM's products or services with statements different from or beyond the parameters stated by WM for that product or service voids all express and any implied warranties for the associated WM product or service, is an unfair and deceptive business practice, and WM is not responsible nor liable for any such use.

## ADDRESS:

Wolfson Microelectronics plc  
20 Bernard Terrace  
Edinburgh  
EH8 9NX  
United Kingdom

Tel :: +44 (0)131 272 7000

Fax :: +44 (0)131 272 7001

Email :: [sales@wolfsonmicro.com](mailto:sales@wolfsonmicro.com)