

WMS-42PLUS3

USER'S MANUAL

P/N: 205G0000WMS422, V1.1
All rights reserved

Acknowledgments

Greeting & Setup

Thank you for purchasing the WMS-42PLUS3 unit. We wish that this unit will be durable and reliable in providing your needs. Please follow the instructions below to ensure the unit continues to have high performance. Please read the user's manual carefully before performing the installation.

Please use the power cord designated for the product. When an extension cord is required, use one with the correct power rating. The cord must be grounded and the grounding feature must not be defeated. The product should be installed on a flat surface to avoid tipping. Space should be maintained between the back of the product and the wall for proper ventilation.

Unpacking

After opening the carton, there will be a unit with an accessory box and 2 stands (options). Examine the contents to see if there are damages to the unit and if all accessories are present.

Setting up

Please read this manual carefully and remember to keep this manual for future reference.

Safety Instructions & Cleaning

The unit has undergone various tests in order to comply with safety standards. Inappropriate use may be dangerous. Please remember to follow the instructions below to insure your safety during the installation and operating process.

Transporting & Placement of unit

- 1. When moving the unit on a cart; be very cautious. Quick stops, excessive forces and uneven surfaces may cause the cart to overturn thus risking the unit to fall to the ground.*
- 2. If the Monitor display unit does fall to the ground, immediately turn the power off and disconnect cords. Then contact a service technician for repairs. Continual use of the unit may result cause a fire or electric shock. Also, do not repair the unit on your own.*
- 3. Having two or more people transporting the display unit is recommended. In addition, when installing the open frame by suspending it also requires two or more people.*
- 4. Before suspending the unit, make sure the material used for suspension is sturdy and stable. If not properly suspended, the display unit may fall and cause serious injury to people standing nearby as well as to the unit itself.*
- 5. If you wish to mount the display unit, remember to use only the mounting hardware recommended by the manufacturer.*

Electrical and Power Source Related

- 1. This Monitor display unit must operate on a power source as shown on the specification label. If you are not sure what type of power supply used in the area, consult your dealer or local power supplier.*
- 2. The power cords must not be damaged. Applied pressure, added heat, and tugging may damage the power cord.*
- 3. The power cord must be routed properly when setup takes place. We advise that this aspect measure is to prevent people from stepping on the cords or while the unit is suspended to prevent flying objects from getting tangled with the unit.*
- 4. Do not overload the AC outlets or extension cords. Electrical shocks or fires may occur from overloading.*
- 5. Do not touch the power source during a thunderstorm.*
- 6. If your hands are wet, do not touch the plug.*
- 7. Use your thumb and index finger, grip firmly on the power cord to disconnect from the electrical socket. By pulling the power cord, may result in damaging it.*
- 8. If the unit is not going to be in use for an extended period of time, remember to disconnect the unit.*
- 9. Connect the unit to a power source with the same numerical value as spec. label shown. Please use only the power cord provided by the dealer to ensure safety and EMC compliance.*

Various Factors of Environment

- 1. Do not insert objects into the openings.*
- 2. Do not have liquids seep into the internal areas of the Monitor display unit.*
- 3. Having liquids seep in or inserting objects into the unit may result in electric shocks from taking and/or short circuiting the internal parts.*

4. Do not place the Monitor display unit in the presence of high moisture areas.
5. Do not install the Monitor display unit in a wet environment.
6. Do not place near unit near heat generating sources.
7. Do not place the unit in a location where it will come in contact with fumes or steam.
8. Remember to keep the Monitor display unit away from the presence of dust.
9. If water has flow in or seep in, immediately disconnect the open frame unit. Then contact a service technician for repairs.

Ventilation Spacing

1. Do not cover or block the openings on the top and back sides of the display unit. Inadequate ventilation may cause overheating thus reducing the lifespan of the unit.
2. Unless proper ventilation is present, do not place unit in an enclosed area; such as a built-in shelf. Keep a minimum distance of 10 cm between the display unit and wall.

Cleaning the unit

- (1) Remember to turn off the power source and to unplug the cord from the outlet before cleaning the unit.
- (2) Carefully dismount the unit or bring the unit down from suspension to clean.
- (3) Use only a dry soft cloth or clean room wiper when cleaning the LCD panel or touch screen surface. Use a soft cloth moistened with mild detergent to clean the display housing.
- (4) Remember to avoid having liquids seep into the internal components.

Servicing, Repairing, Maintenance & Safety Checks

1. If the unit is not functioning properly, observe the performance level of the display closely to determine what type of servicing is needed.
2. Do not attempt to repair the Monitor display unit on your own. Disassembling the cover exposes users' to high voltages and other dangerous conditions. Notify and request a qualified service technician for servicing the unit.
3. If any of the following situations occur turn the power source off and unplug the unit. Then contact a qualified service technician
 - (a) A liquid was spilled on the unit or objects have fallen into the unit.
 - (b) The unit is soaked with liquids.
 - (c) The unit is dropped or damaged.
 - (d) If smoke or strange odor is flowing out of the open frame unit.
 - (e) If the power cord or plug is damaged.
 - (f) When the functions of the unit are dysfunctional.
4. When part replacement is needed. Make sure service technician uses replacement parts specified by the manufacturer, or those with the same characteristics and performance as the original parts. If unauthorized parts are used it may result in starting a fire, electrical shock and/or other dangers.

Battery Installation

Follow below instructions and notice the caution for replacing and disposing of the RTC Lithium battery CR2032 for safety consideration.

CAUTION:

There is danger of explosion, if battery is incorrectly replaced. Replace only with the same or equivalent type recommended by the manufacturer. Dispose of used batteries according to the manufacturer's instruction.

The specification is subject to change without notice.

Version Change History

Date	Version	Description	Remark
2011/12/27	1.0	First release	
2012/2/8	1.1	Update rear view photo in page 19 Add mounting bracket information	

CONTENTS

Product Description	6
Package Contents	6
Specification	7
Installation and Operation	12
Dimension Drawing	17
System view and System Installation	19
Front View	19
Rear View	19
Computer IO	20
Bottom I/O	21
System Software Installation	22
Installing the Drivers	22
Notice	22
Remote Controller	23
Functions	23
a. Turn on/off LCD display	23
b. Turn on/off PC	23
c. Select display video signal source	23
d. Synchronize video input signal and AD board output signal	23
e. Adjust display setting	23
Navigating the OSD Menu	24
a. Display OSD main menu	24
b. Select the menu you want to adjust	24
c. Adjust the setting	24
d. Exit the OSD menu	24
Color/bright	24
Image setting	26
OSD menu	26
Signal Source	27
Audio	27
Special	28
Summary	28
Trouble Shooting	29
BIOS setup information	30
Appendix	40
A. Jumper settings and Connectors	40
B. Wake UP on LAN Function	52

Product Description

The WMS-42PLUS3 is composed of TFT LCD panel display and industrial level computer. It is designed to meet the demanding performance requirements of today's business, public display and industrial applications.

It is ideal for applications such as

- KIOSK
- Retail and restaurants
- Corporate communication
- Public signage
- Casino & gaming signage
- Medical information
- Financial centers & banks
- Government & military
- Education
- Entertainment venues
- Sports arenas
- Public transportation signage
- Advertisements LCD display applications.

Open-frame series are available for system builder or integrators for the environment that has been decorated.

Package Contents

Before using this WMS-42PLUS3 unit, please make sure that all the items listed below are present in your package

1. WMS-42PLUS3 unit
2. Power Cable x 1
3. Remote controller x 1
4. CD title (drivers, user's manual) x 1
5. Accessories of option parts

If you find that any item to be missing or appear to be damaged, contact your dealer immediately. DO NOT throw away the packing material or shipping carton in case you need to ship or store the LCD monitor in the future.

Specification

System

CPU Intel® Socket LGA 1156, Support Intel Core i3/i5/i7 and Pentium G9650 CPU

CPU listing:

CORE i7-860, 2.80G, 8M Cache (w/o integrated graphic)

CORE i5-750, 2.66G, 8M Cache (w/o integrated graphic)

CORE i5-660, 3.33G, 4M Cache

CORE i3-540, 3.06G, 4M Cache

Pentium G9650, 2.80G, 3M Cache

System bus 2.5GT/s

Chipset Intel® Q57 Express PCH

Audio Realtek ALC268 HD Audio Codec

LAN Marvell 88E8071 Giga LAN x 1

Memory Two DDR3 1066/1333 DIMM sockets (dual channels), supports max. 8 GB

I/O Winbond W83267UHG

Serial ATA SATA II controller (3.0Gb/sec) Port x 2

USB 5 USB 2.0 port (external I/O x 3, internal pin head x 2)

Serial COM 1 RS-232 (internal pin head), 1 RS-232/422/485 at I/O side

Mini PCIe One Mini PCI express slot

WDT 1~255 second/minutes, software programmable

Speakers (landscape, 10W+10W) (volume level controllable by IR remote control)

BIOS

Brand: AMI

Flash ROM size: 64Mb SPI

Support RTC wakeup /Wake on LAN /Power on after power failure/PnP/ACPI/RTC

Display

Panel 42" LED backlight LCD module

brand model	AUO T420HW08 V0
Resolution (pixel)	Full HD (1920 x 1080)
Active Area (mm)	930.24(H) x 523.26(V)
Outline(mm) (w/inverter)	968.4(H) x 564.0 (V) x 25.5(D)
Number of Colors	10bit(8 bit + FRC),1073.7M
View Angle (H/V)	(U/D/R/L CR>10) 89/89/89/89
Brightness (cd/m ²)	450
Color Gamut	(NTSC) 72%
Contrast Ratio	4000:1
life time	30000 hours

Touch (design in, option)

IR touch (single point)

Model name	T42D00-02
Type	Infrared rays
Glove	Yes
Stylus	Yes
Vandal	No
Interface	USB
Light Transmission	>=92%
Hardness	Glass hardness - Mohs 7
Glass thickness	3mm
Linearity	1.5mm
Active area (mmxmm)	934x527
Resolution	4096x4096

Lifetime	7 years
-----------------	---------

IR touch (dual point)

Model name	T42D00U-A02-02
Type	Infrared rays
Glove	Yes
Stylus	Yes
Vandal	No
Interface	USB
Light Transmission	>=92%
Hardness	Glass hardness - Mohs 7
Glass thickness	3mm
Linearity	1.5mm
Active area (mmxmm)	934x527
Resolution	4096x4096
Lifetime	7 years

Graphic Resolution Support Mode List

OS: Microsoft Windows® XP Pro, XP embedded, Windows 7

VGA for VESA Standard Timing

No.	Resolution	fV (Hz)	fH (KHz)	Pixel Rate (MHz)
1	800x600	60	37.9	40.000
2	1024x768	60	48.4	65.000
3	1280x720	60	44.8	74.500
4	1280x768	60	47.4	68.250
5	1280x1024	60	64.0	108.000
6	1366x768	60	47.7	85.500
7	1920x1080	60	67.2	173.000

Digital source

No.	Resolution	fV (Hz)	fH (KHz)	Pixel Rate (MHz)
1	800x600	60	37.9	40.000
2	1024x768	60	48.4	65.000
3	1152x864	60	53.7	81.675
4	1280x768	60	47.4	68.250
5	1280x960	60	60.0	108.000
6	1280x1024	60	64.0	108.000
7	1360x768	60	47.7	85.500
8	1366x768	60	47.7	85.500
9	1920x1080	60	67.0	148.500

Storage

HDD 2.5" SATAII HDD drive x 1 (integrated with PC module)

Expansion

Mini PCI-E	x 1
PCI-Ex16	x 1
PCI-Ex4	x 1

External I/O on Side

USB	USB 2.0 x 3
COM	DB-9 x 1 (RS-232/422/485)
LAN	RJ-45 x 1 (Gigabit Ethernet)
Audio	Mic-in, Line out audio jacks
DVI-D	output x 1 (Supported by VGA card)

External I/O on bottom

VGA output	x 1
VGA input	x 1
IR receiver	x 1 (optional and will disable default IR receiver function if this port is plugged)
Line in	x 1
Line out	x 2

Internal connectors of display AD board

DVI-D input	x 1
VGA input	x 1
RS232 input	x 1

Power

Power input	Direct AC connector, ATX power supply to computer board, 100~240VAC, 50/60Hz
Max power consumption and electric current:	225W, 2.3A
Power Switch	Main switch to turn on/off AC power (at the bottom side) Switch to turn on/off mother board (at the external I/O of PC side)
Power LED	Power and HDD indicator at PC board external I/O side (LED colors: Power: Green / Orange: HDD accessing)
PC module power and LCD display power	are separately controllable by IR remote control
Display status LED	is located at left bottom side (Power on: Green / Stand by: Red)

Mechanical & Environmental

Mainbody	SECC, black (Panton no. 8238), power coating
Operating Temperature	0°C ~ 40°C
Storage Temperature	-20°C ~ 60°C
Operating Humidity	10 ~ 90%
Storage Humidity	10 ~ 90%
Noise Level	35 dB (25°C)
Kensington lock hole	Computer module I/O side x 1
IR remote control sensor	at front bezel left bottom corner, with flat top light guide to receiver IR control signal

Dimension and Weight

Outline dimension (WxHxD, mm):	
no touch:	980*573*80 / with touch: 980*573*93.5
Weight (Kg):	no touch: 27 / with IR touch: 33 Kg

Options:

1. Wireless LAN
2. Graphic card (graphic card is a must if CPU is CORE i7-860 or CORE i5-750)
3. Stand x2
4. Wall mount bracket
5. IR/COM cable to IR receiver (185cm) and with location on the screen to mount

Packing list:

1. WMS-42PLUS3
2. Power Cable x 1
3. Remote controller x 1
4. CD title x 1

5. Accessories of option parts

Regulatory

FCC-A, CE (EMC), UL/cUL

Shock

Operating: 15g/0.53 oz, 11 ms, half sine wave

Vibration

(NON-OPERATING)

FREQUENCY: 5 - 100- 5Hz (Log sweep)

FORCE: 11.77 m/s² (1.2 G)

TIME: 20 MINUTES

CYCLE TIME: 1 MINUTE

DIRECTION: X,Y,Z

Drop

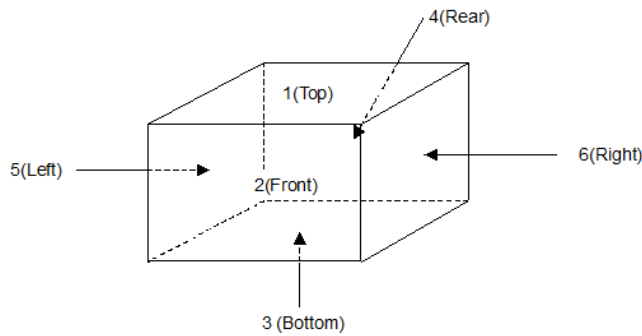

	Drop Point	Drop Times
1	Corner in contact with the bottom, left and front side	2-3-5 1
2	Edge where the bottom and right side are in contact with each other	3-6 1
3	Edge where the front and the bottom side are in contact with each other	2-3 1
4	Bottom side	3 1
5	Front side	2 1
6	Right side	6 1
7	Left side	5 1
8	Rear side	4 1
9	Top side (Less than 30kg only)	1 1

Drop Height:

PACKING WEIGHT	BOTTOM SURFACE	LEFT and RIGHT	OTHER POINT [cm]
----------------	----------------	----------------	------------------

<i>[kg]</i>	<i>[cm]</i>	<i>SURFACE [cm]</i>	
<i>Less than 10</i>	<i>60</i>	<i>40</i>	<i>50</i>
<i>10 or over</i>	<i>55</i>	<i>35</i>	<i>45</i>
<i>20 or over</i>	<i>50</i>	<i>30</i>	<i>40</i>
<i>30 or over</i>	<i>45</i>	<i>25</i>	<i>35</i>
<i>40 or over</i>	<i>40</i>	<i>20</i>	<i>30</i>
<i>50 or over</i>	<i>35</i>	<i>15</i>	<i>25</i>
<i>60 or over</i>	<i>30</i>	<i>15</i>	<i>20</i>
<i>100 or over</i>	<i>30</i>	<i>No Need</i>	<i>No Need</i>

Configurations:

1. *WMS-42PLUS3BK Corei5 750 2.66G CPU- 4G RAM- 250G HDD*
2. *WMS-42PLUS3BKIT Corei5 750 2.66G CPU- 4G RAM- 250G HDD*
3. *WMS-42PLUS3BKI2 Corei5 750 2.66G CPU- 4G RAM- 250G HDD*

Installation and Operation

The procedures for setting up your WMS-42PLUS3 are as follows:

1. Power cable connection:

Connect the power cord to the AC inlet.

2. Power on:

- a. Switch on the power of your monitor (switch is located near connector of power cord)
- b. Switch on the power of integrated computer.

Or

Use remote controller to power on display and integrated computer.

3. Power off:

- a. Switch off the power of integrated computer (at the I/O port).
- b. Switch off the power of your monitor (switch is located near connector of power cord)

Or

Use remote controller to power off display and integrated computer in one time

4. Stand (option):

- a. Place the monitor face down on the stable and flat platform.
- b. Mount stands on:
 - Insert stand into the stand holes.
 - Use screw driver and M4xL10 screws in accessory box to fasten stands on WMS-42PLUS2E

Dismount stands:

- Use screw drivers to unscrew the M4xL10 screws from stand frame
- Store the screws in proper place for next usage



M4 X L10 screws



5. PC external IO cover (option):

- a. Fix cover by fastening 2 screws chassis

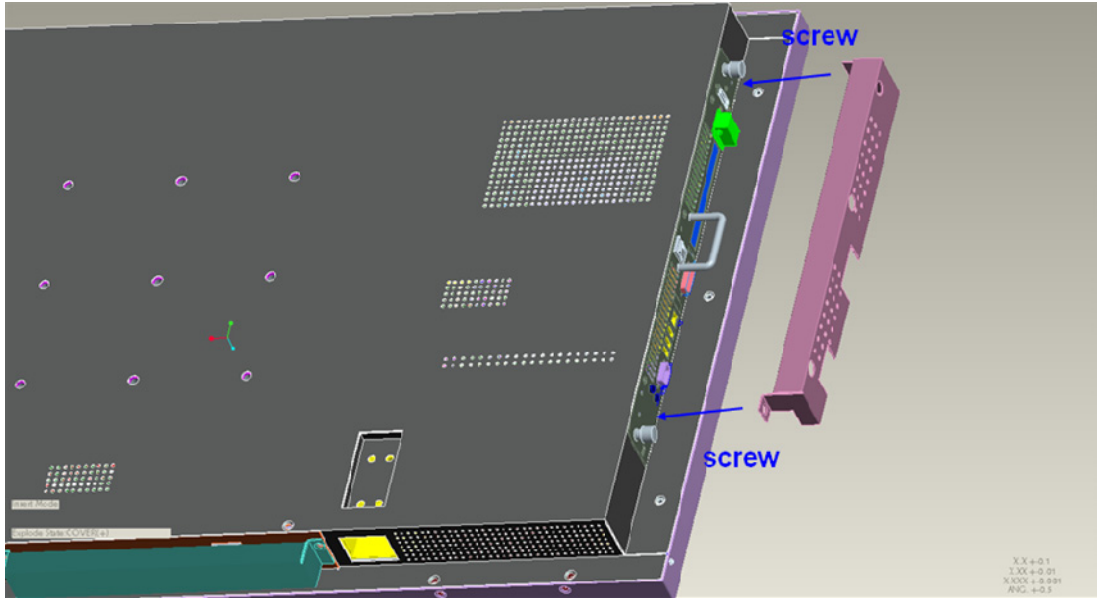

b. Result, refer to below picture

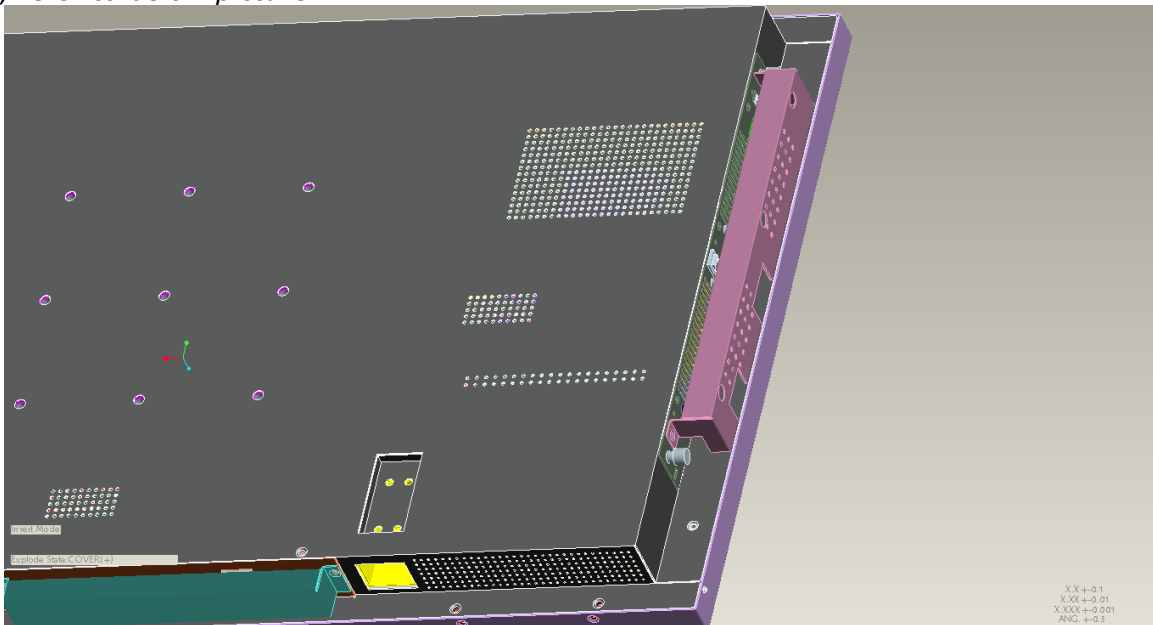

6. AD board external IO cover (option):

a. Fix cover by fastening 2 screws chassis

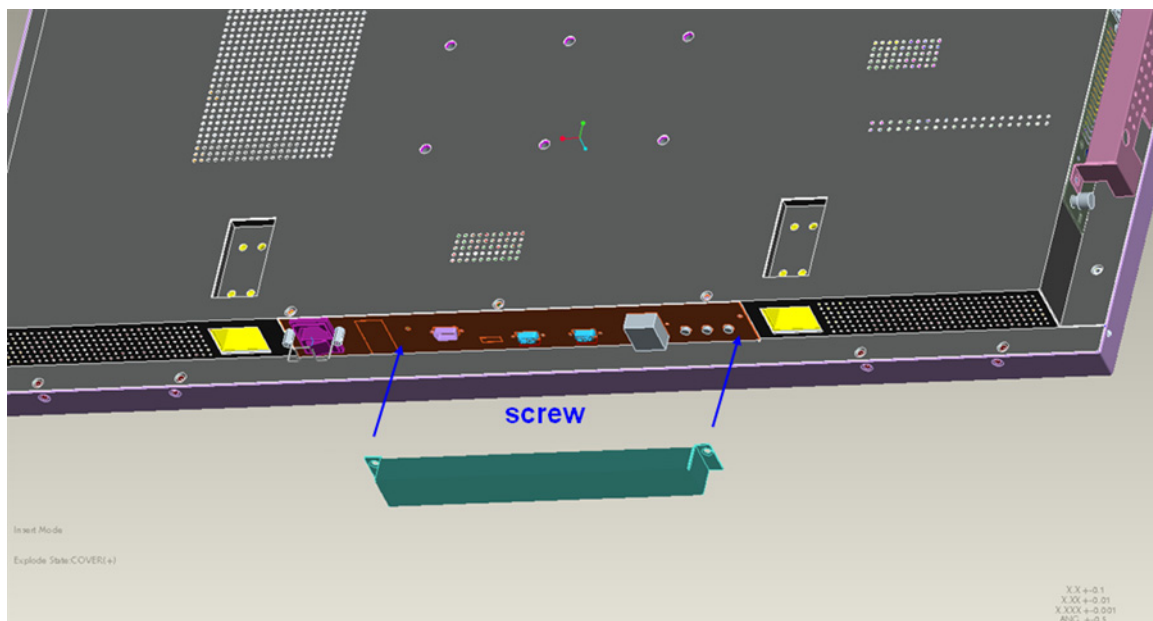

b. Result, refer to below picture

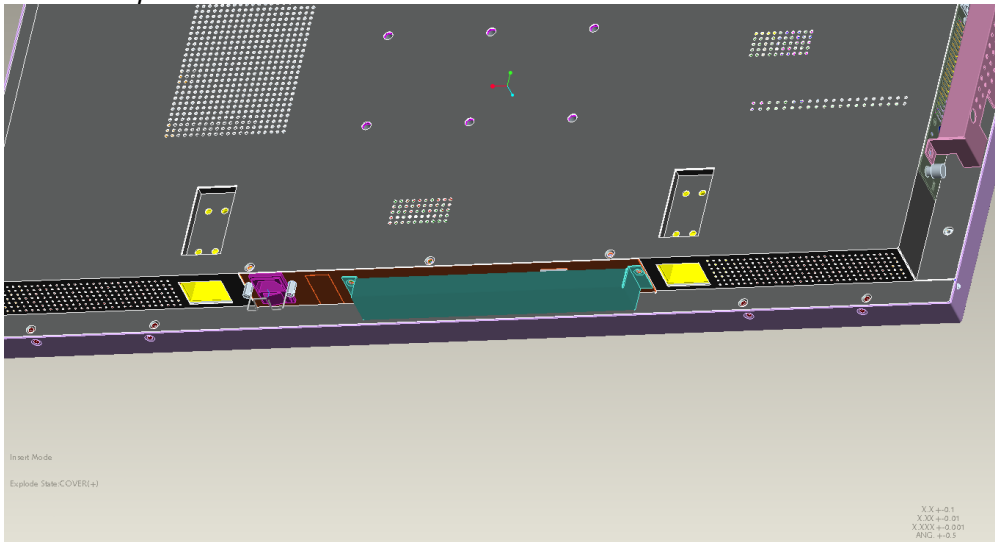

7. Remote IR control (option):

In order to reduce bezel width IR receiver is not located within front bezel. An IR receiver board is designed to link IR receiver connector which located at bottom side. System integrator can integrate IR receiver board within the decorations. Or user can keep it unplugged till when use want to remotely control system, use can plug the this cable to control, then unplugged it after remotely control is done.

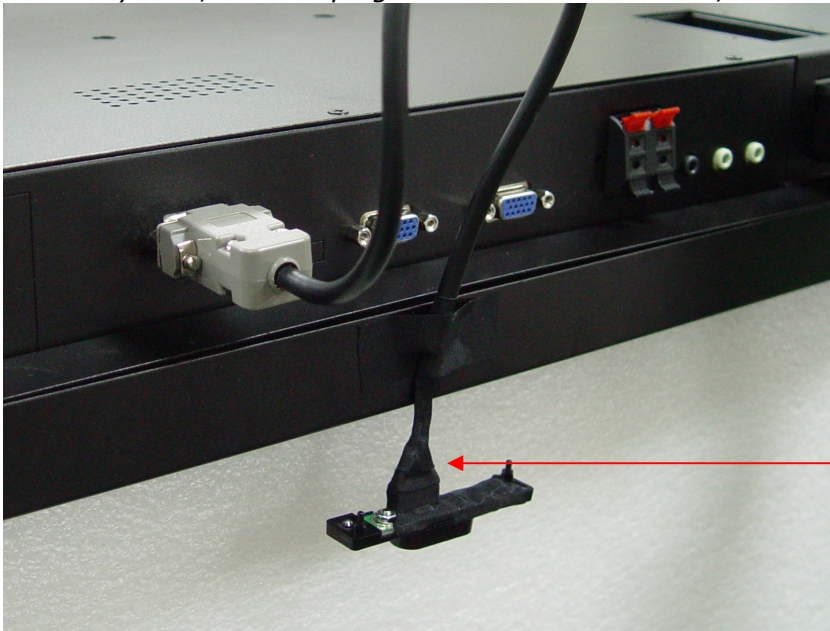

Remote control IR receiver

8. Wall mount bracket installation:

Specification

HT-A06

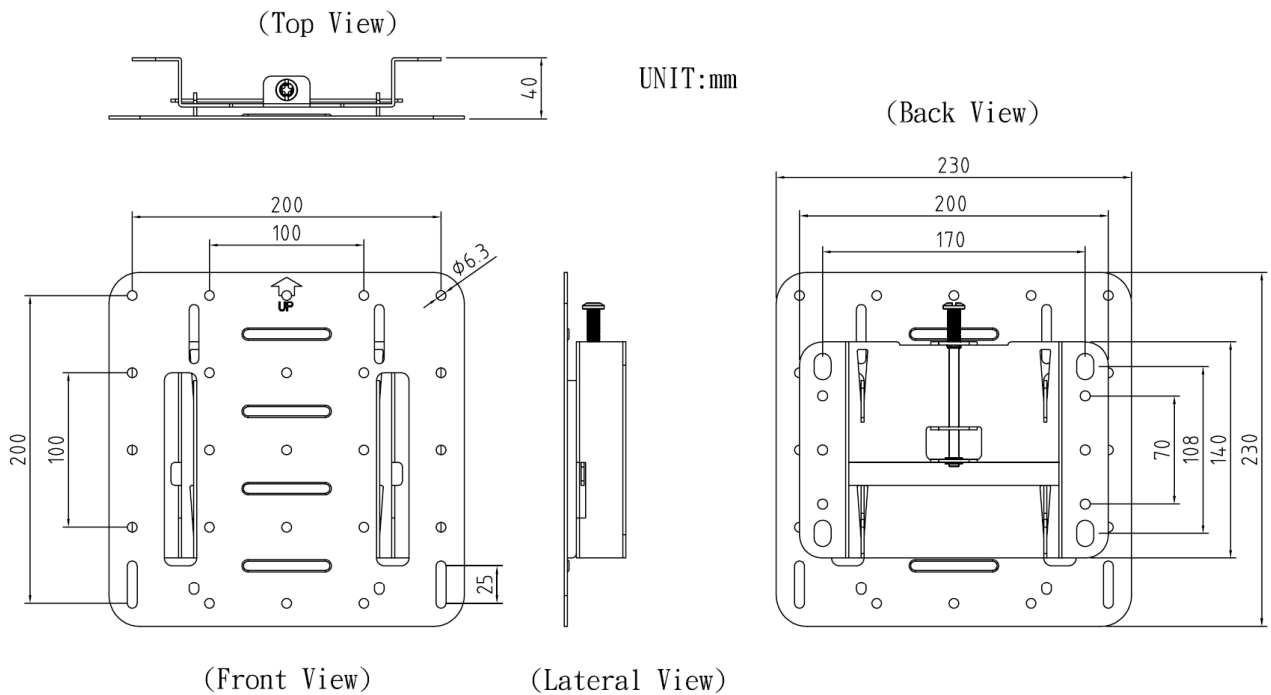

1. Product Spec :

- ◎Max. Load : 80KG
- ◎Hole dimension : 200mmX200mm
- ◎Viewing angle : NO
- ◎The distance to the wall : 4 cm
- ◎Weight : 1.7 KG

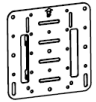
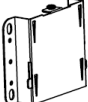
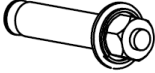
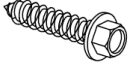

2. Parts Name :

- ◎After opening, please inspect all components are complete.
- ◎The Screw specifications and hole dimensions in each display is different, please confirm the type of screws before installing.

<p>A</p>  <p>TV Bracket---1PCS</p>	<p>B</p>  <p>Wall Bracket---1PCS</p>	<p>C</p>  <p>φ10X56 Wall Anchor---4PCS</p>	<p>D</p>  <p>φ6.5X28 Wood Screw---6PCS</p>
<p>E</p>  <p>M6X10 Screw---6PCS</p>	<p>F</p>	<p>G</p>	<p>H</p>

Installation

HT-A06

1. Choice the suitable wall's material :

- ⊙The wall at least 5cm thick and make sure the material is suitable for installation.
- ⊙For a wooden wall, please choose wood screw 6pcs $\phi 6.5 \times 28 \text{mm}$ (D)
- ⊙For a concrete wall, please choose wood wall anchorscrew 4pcs $\phi 10 \times 56 \text{mm}$ (C)

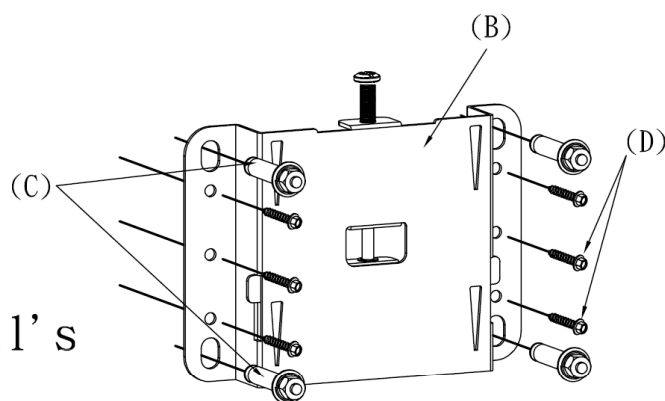

2. Connect wall bracket and display :

- ⊙Make sure the display is turn off before installing.
- ⊙Use 6pcs M6x10 (F) screw and 6pcs to assemble the TV bracket to the LCD TV.

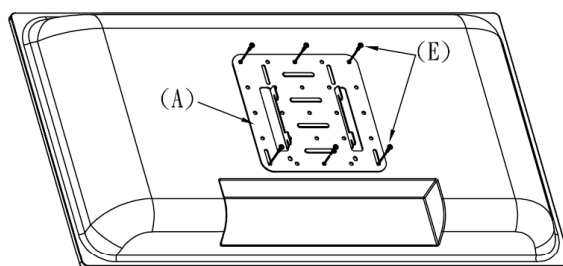

3. Installing wall bracket :

- ⊙ 2 people hold the display is suggested when install.
- ⊙Make sure the two brackets are locked and secure.

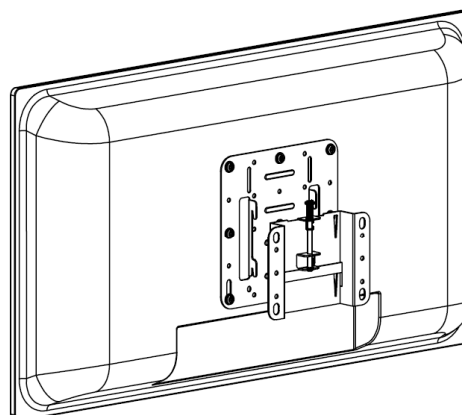

4. Locking wall bracket :

- ⊙Please lock the anti-drop shaft to avoid the bracket fall off.

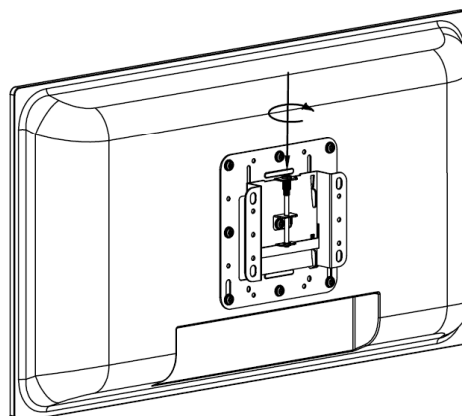
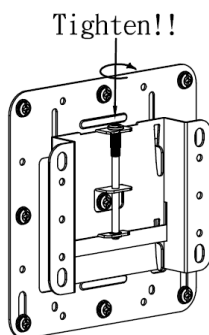

Dimension Drawing

WMS-42PLUS3 BK:

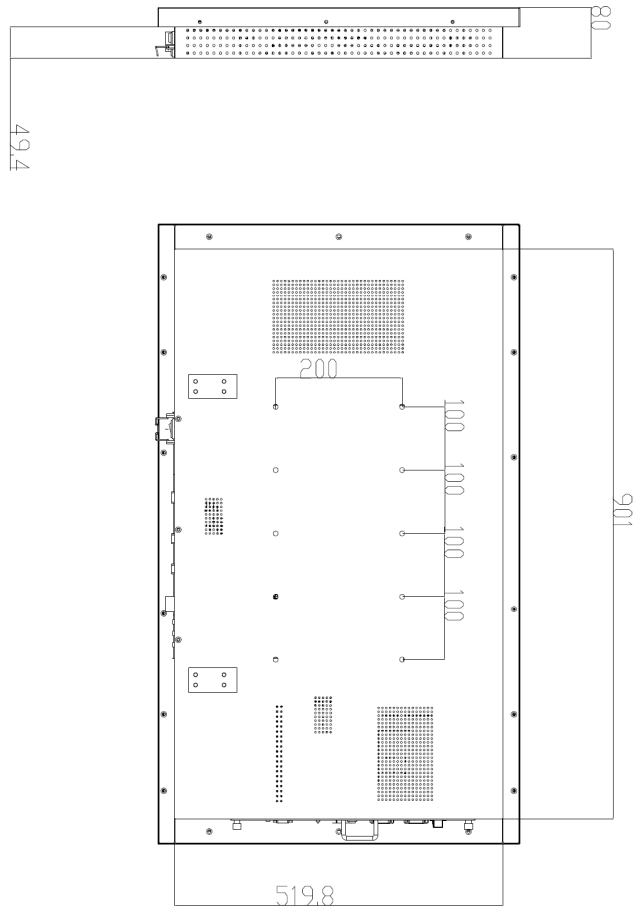
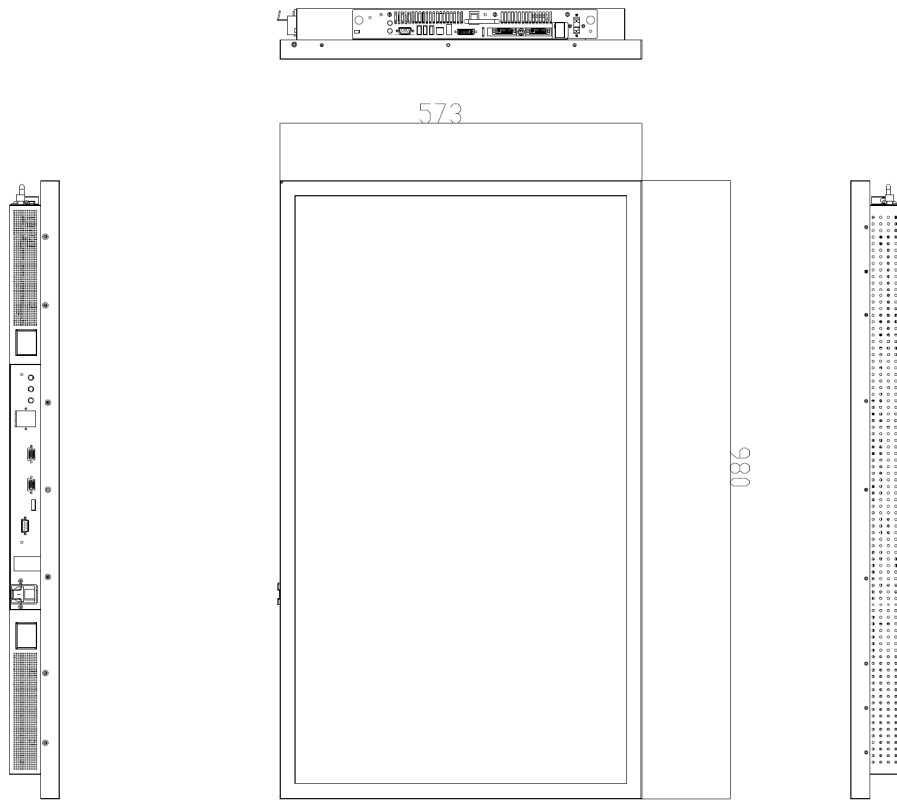

WMS-42PLUS3 BKIT/BKI2:

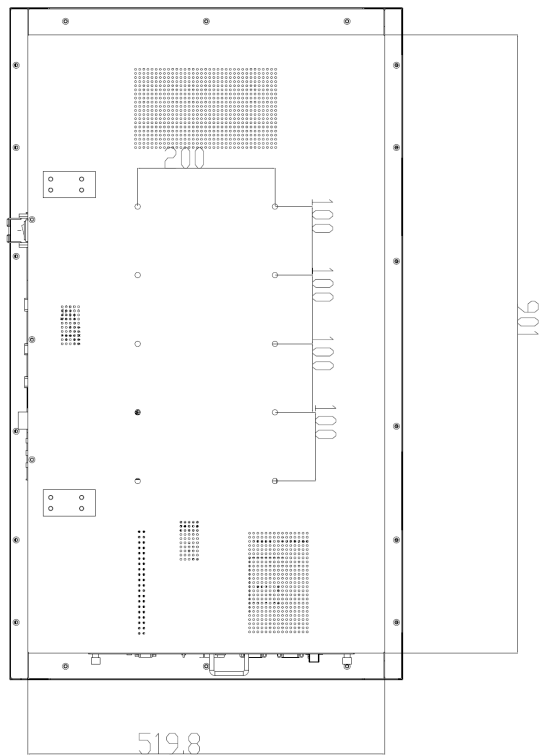
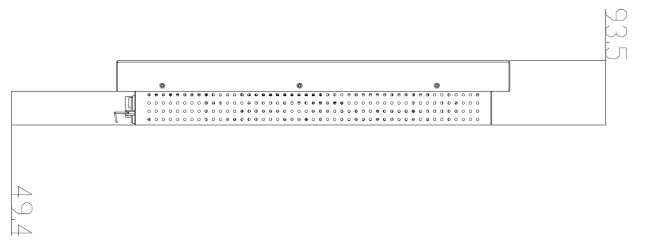
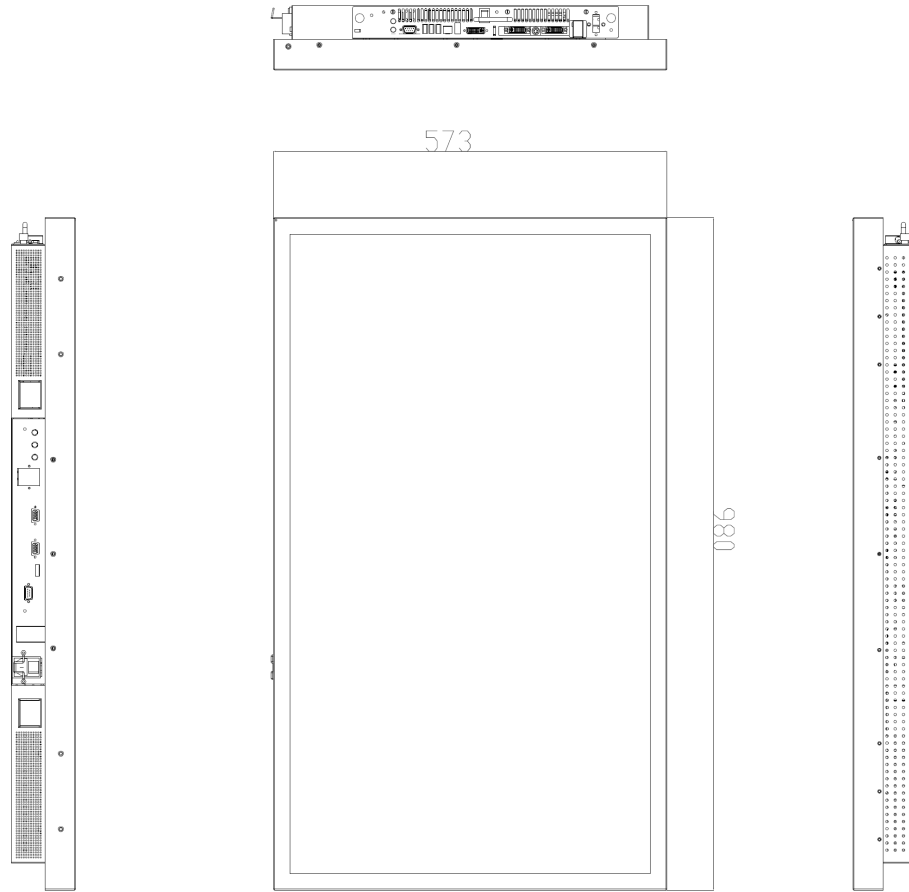

System view and System Installation

Front View



Rear View



Computer IO

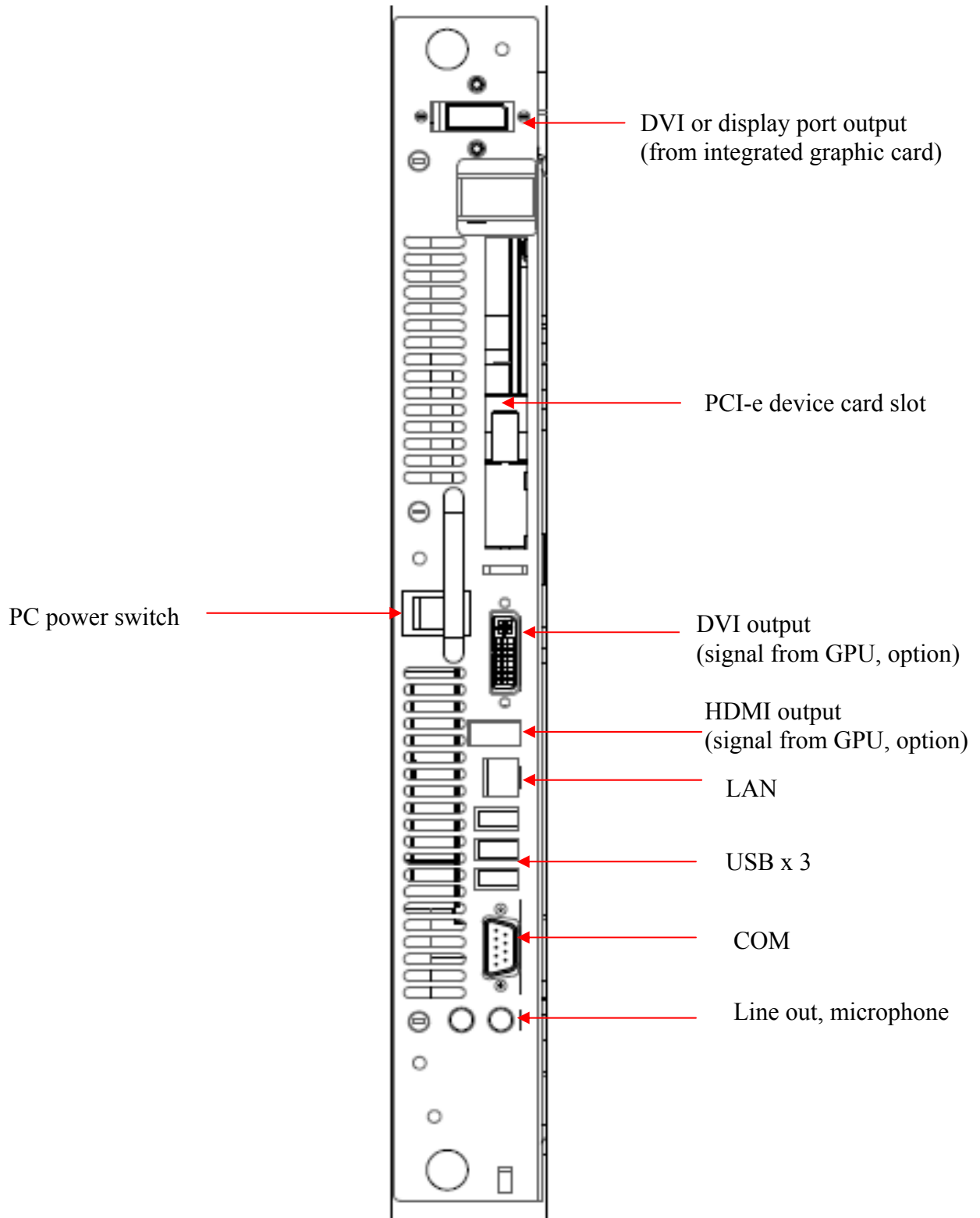

Bottom I/O

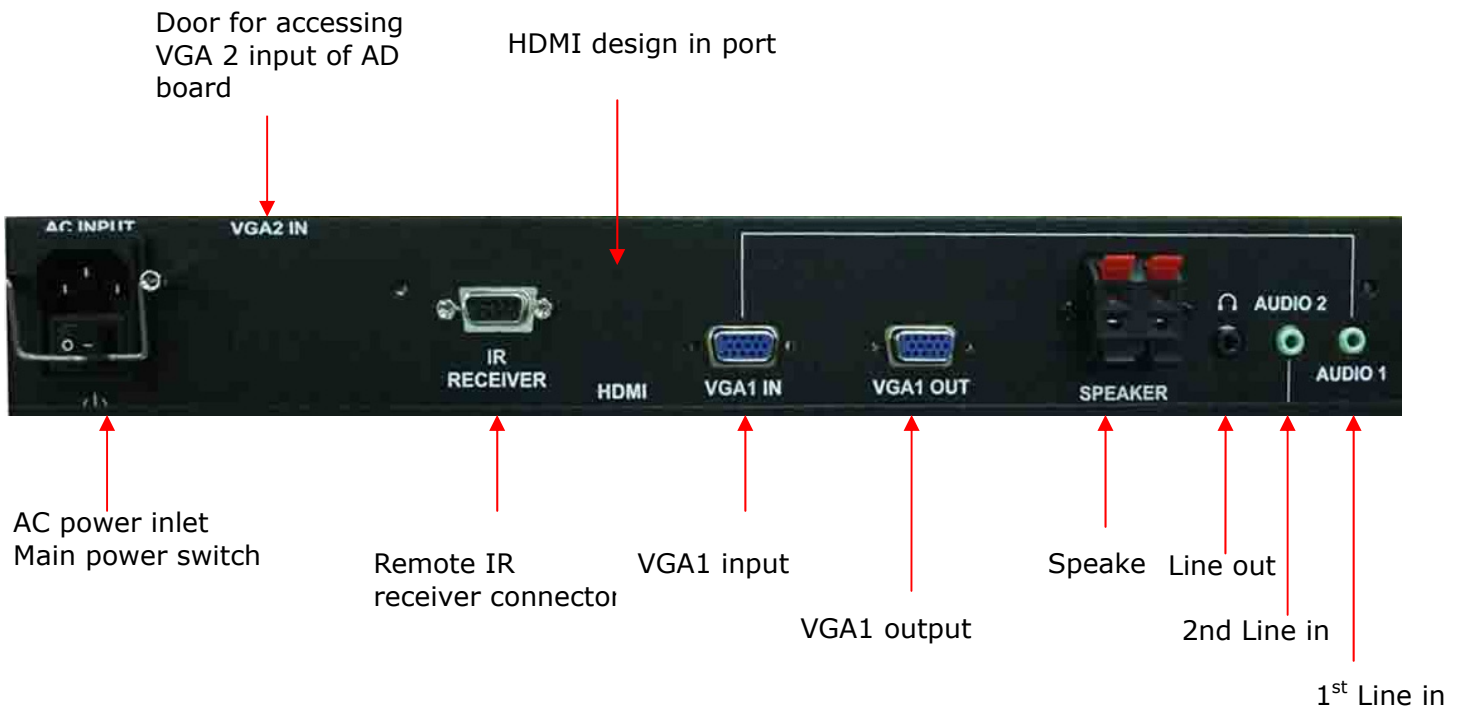

1st Line in – VGA 1

2nd Line in – VGA 2 (internal)

Signal cable connection:

The LCD public display is designed to work with second video sources. Due to possible deviations between these video sources, you may have to make some adjustment to the monitor settings when switching between these sources. These adjustments are made from the OSD menu. This figure shows the signal connectors of the AD board to integrated computer.

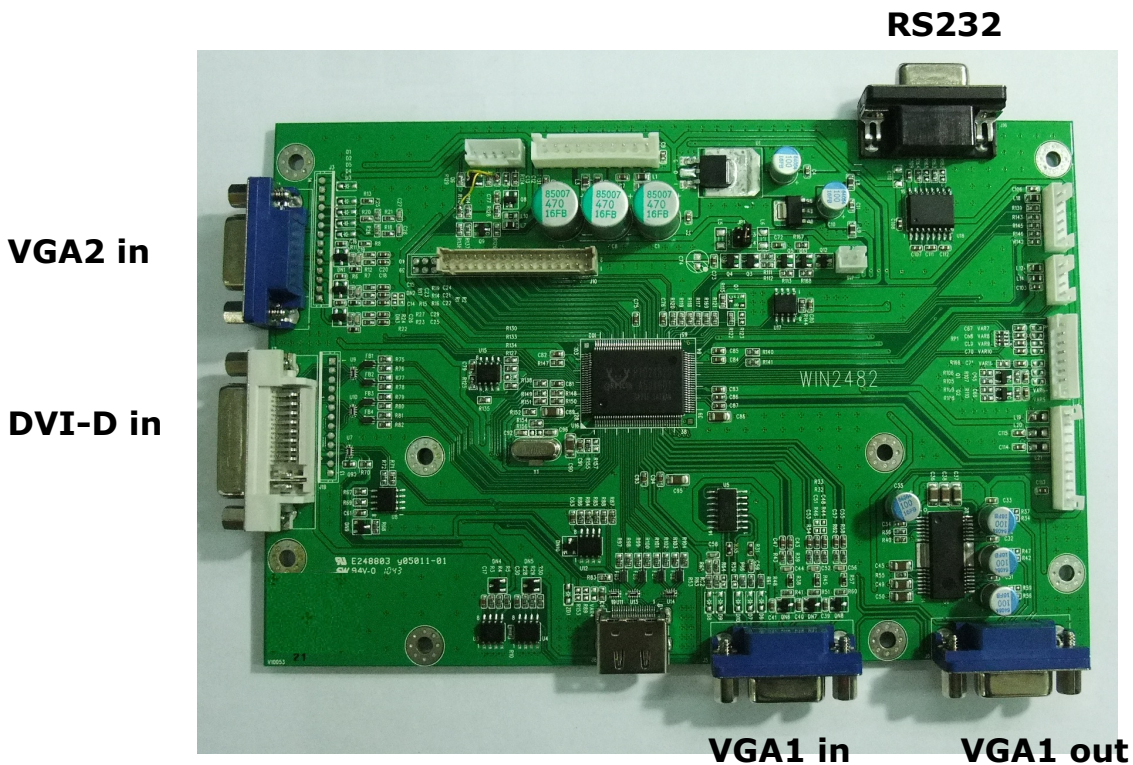

System Software Installation

Recent releases of operating systems from major vendors include setup programs, which load automatically and guide you through hard disk preparation and operating system installation. The guidelines below will help you determine the steps necessary to install your operating system on the WMS-42PLUS3 hard drive.

NOTE: Some distributors and system integrators may have already pre-installed system software prior to shipment of your WMS-42PLUS3.

Installing software requires an installed HDD. Software can be loaded in the WMS-42PLUS3 using any of below methods:

Method 1: Use the Ethernet

You can use the Ethernet port to download software from the Net to the HDD that has been pre-installed in WMS-42PLUS3.

Method 2: Use a External CD-ROM

You can use the external CD-ROM to transmit the software to the HDD that has been pre-installed in the WMS-42PLUS3.

In order to boot up system from USB-CD/DVD drive, please connect USB-CD/DVD drive, turn on computer power, keep on pressing "F11" key, go into BIOS quick boot menu, select "USB-CD ROM", WAIT FOR 20 SECONDS, then press enter, system OS will boot up from USB-CD/DVD drive directly.

Installing the Drivers

After installing your system software, you will be able to set up the LAN, VGA, Audio and USB functions. All drivers are stored in a CD disc, which can be found in your accessory pack. The various drivers and utilities in the disc have their own text files that help users install the drivers and understand their functions.

Notice

- 1. Unplug AC power cables and loose screws before withdrawing mother board tray.*
- 2. Insert and withdraw mother board gently to avoid mother board tray fallen and connector board damaged.*
- 3. Fix screws after mother board tray inserted and connected firmly.*
- 4. Use Kensington lock to secure PC kits.*
- 5. Hand grips are detachable; please keep it in safety place for future usage.*
- 6. For best picture quality, please set display resolution to 1920x1080.*

Remote Controller

The outlook of remote controller is shown as below.

Functions

a. Turn on/off LCD display

Press the "LCD ON/OFF" button to turn on/off display.

b. Turn on/off PC

Press the "ON/OFF" button to turn on/off PC.

c. Select display video signal source

Press the DVI, VGA1, VGA2 to select display video input source (DVI and VGA1 input connectors are at the bottom side, VGA2 input connector is enclosed within chassis).

d. Synchronize video input signal and AD board output signal

Press the AUTO button to synchronize video input signal and AD board output signal to have the best LCD display quality.

e. Adjust display setting

Press MENU, EXIT, ENTER, ▲, ▼, ◀, ▶ buttons to adjust display effects in OSD (on screen display).



Navigating the OSD Menu

a. Display OSD main menu

Press the MENU button to display the main menu on the screen.

b. Select the menu you want to adjust

Press the (▲/▼) buttons to shift the item selections up or down until it is desired, and then press the ENTER button to enter the sub-menu item.

c. Adjust the setting

Press the ENTER button to enter the sub-menu and press the ◀ or ▶ button to adjust the value of setting. Once you adjust the value of setting, the value will be stored automatically.

d. Exit the OSD menu

To return the regular screen viewing, press the EXIT button can close sub-menu one by one. If there is no command respond for 10 seconds (default, can be changed in OSD), OSD menu will be closed automatically.

Color/bright

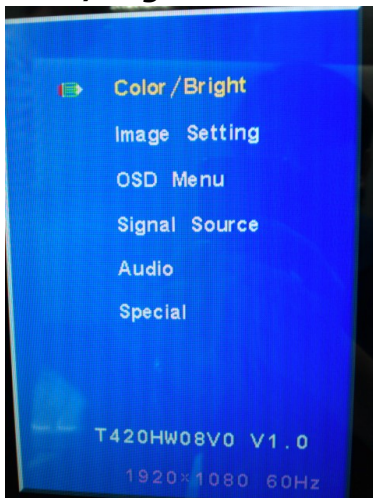

- Contrast: Use to adjust the screen's contrast, press "▶" to increase or "◀" to decrease setting.



- Brightness: Use to adjust the screen's LCD display brightness, press "▶" to increase or "◀" to decrease setting. Please be reminded if auto brightness is ON, brightness cannot be adjusted manually. If you want to turn on/off auto brightness, please go to Auto Brightness item to change setting.

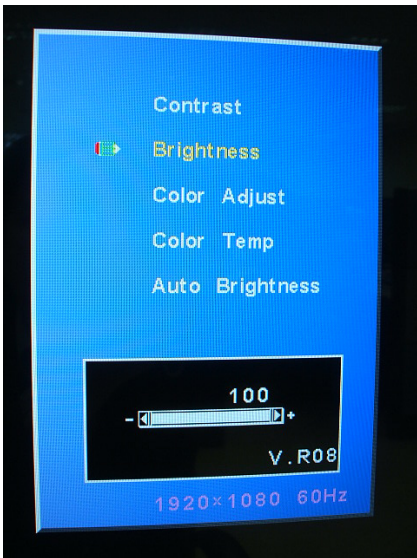

- *Color Adjust: Use to adjust the screen's color level, press Enter to choose color (Red or Green or Blue) you want to change, press "▶" to increase or "◀" to decrease setting. Please be reminded only Color Temp setting is "USER", color level can be adjusted manually. Please go to Color Temp to set color temperature in "USER" mode before you adjust color level.*

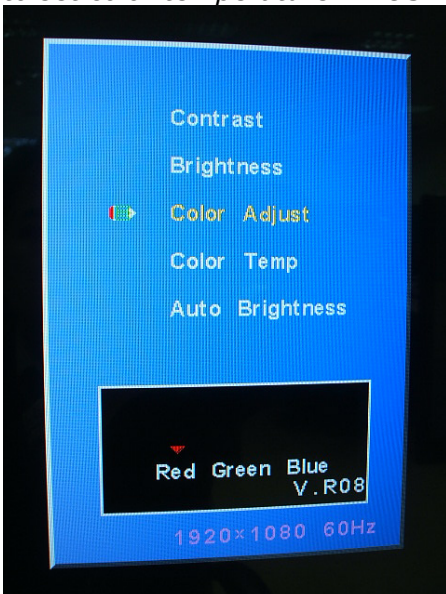

- *Color Temp: By pressing Enter, "▶" or "◀" You can select the screen's color level of the white color field from the default color temperature settings.*

9300K: Use to set value of monitor for the CIE coordinate 9300 color temperature (default)

6500K: Use to set value of monitor for the CIE coordinate 6500 color temperature

7500K: Use to set value of monitor for the CIE coordinate 7500 color temperature

sRGB: Standard RGB color space created by Microsoft and HP

USER: USE to set your desirable color level.

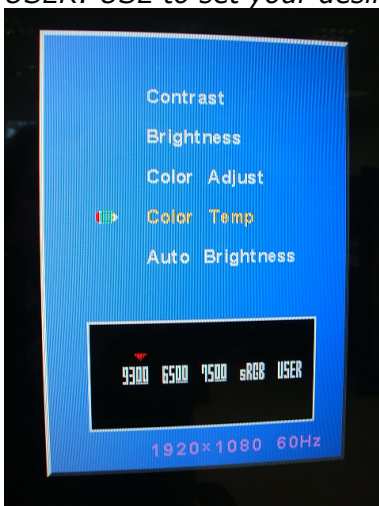
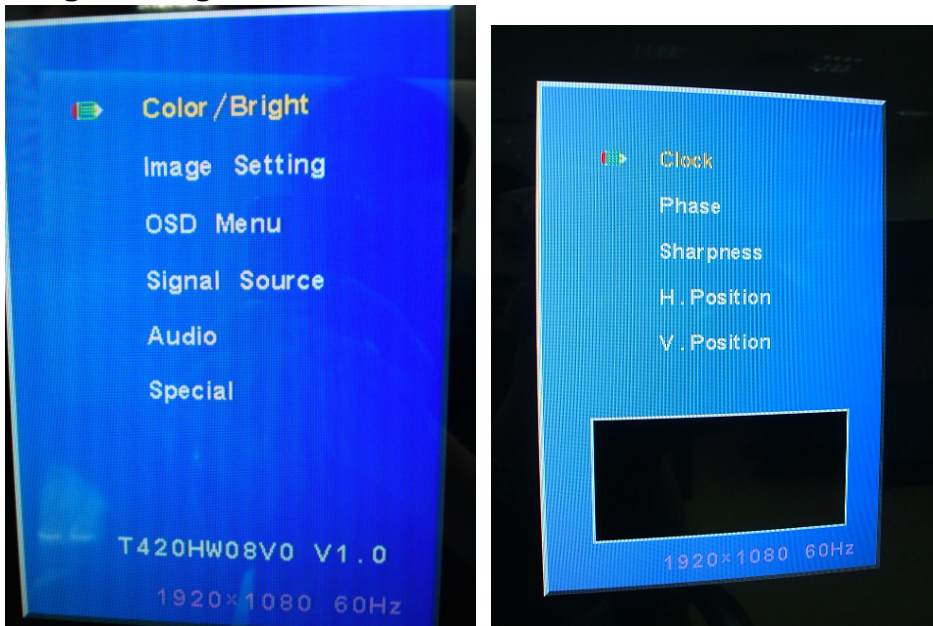
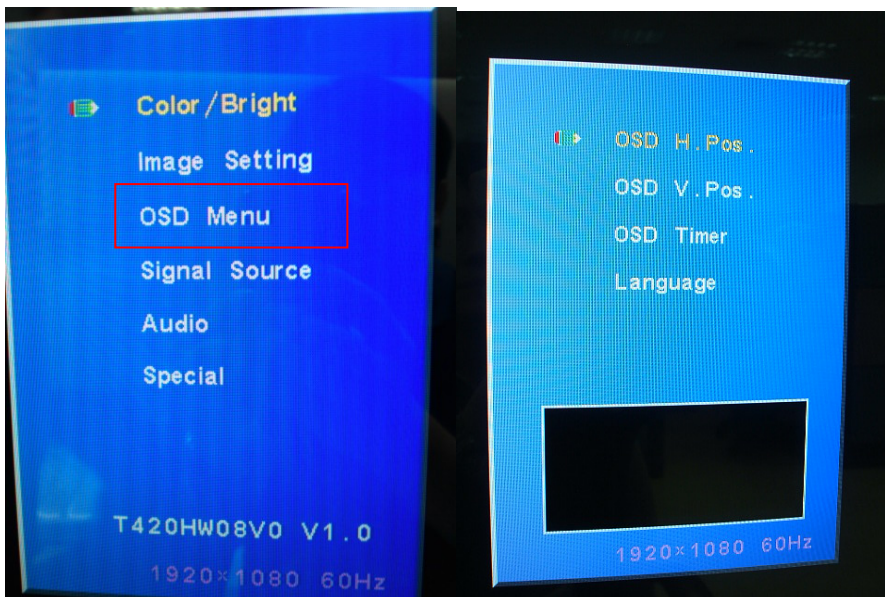

Image setting



- *Clock: Use to adjust VGA input signal ADC PLL value*
- *Phase: Use to check the VGA input signal phase*
- *Sharpness: Use to adjust the screen's sharpness by pressing "►" or "◄"*
- *H. Position: Use to adjust the VGA signal input image to the left or right on the screen by pressing "►" or "◄"*
- *V. Position: Use to adjust the VGA signal input image to the up or down on the screen by pressing "►" or "◄"*

OSD menu



You can set up the OSD situation

- *OSD H. Pos: Use to adjust the OSD menu to the left or right on the screen by pressing "►" or "◄"*
- *OSD V. Pos: Use to adjust the OSD menu to the up or down on the screen by pressing "►" or "◄"*
- *OSD Timer: Setup the timeout of OSD while didn't input change by pressing "►" or "◄"*
The default setting is 25 and the timeout time is 10 seconds
If setting is 0, there will be no timeout time, OSD will be always shown on screen
If the setting is 100, the timeout time is 30 seconds.
- *Language: Select language of OSD display by pressing the (▲/▼) buttons*

Signal Source

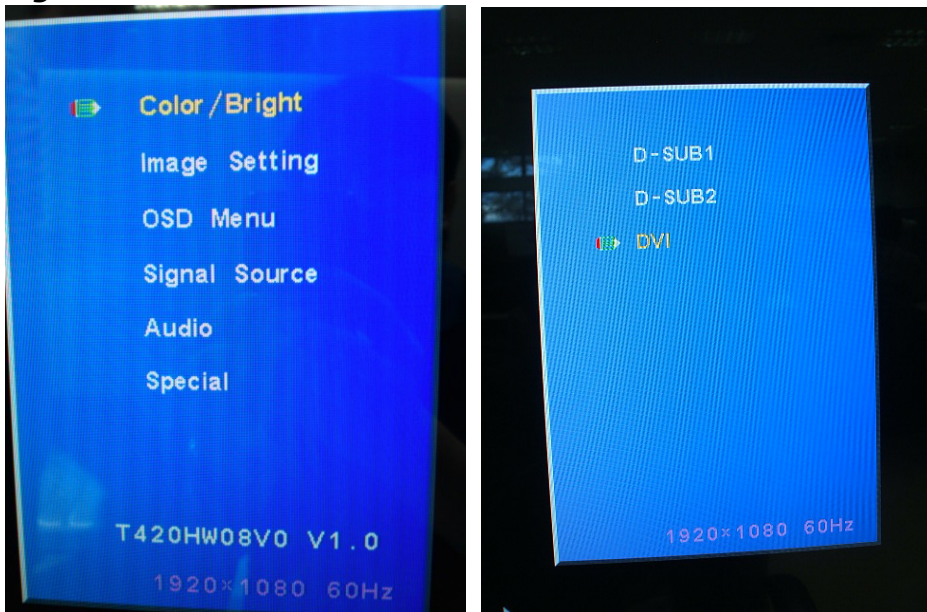

You can select the video input signal source by pressing the (▲/▼) buttons

- D-SUB1: VGA signal input from VGA input connector at display bottom side
- D-SUB2: VGA signal input from VGA input connector enclosed within chassis
- DVI: DVI signal input from DVI input connector at display bottom side.

Audio

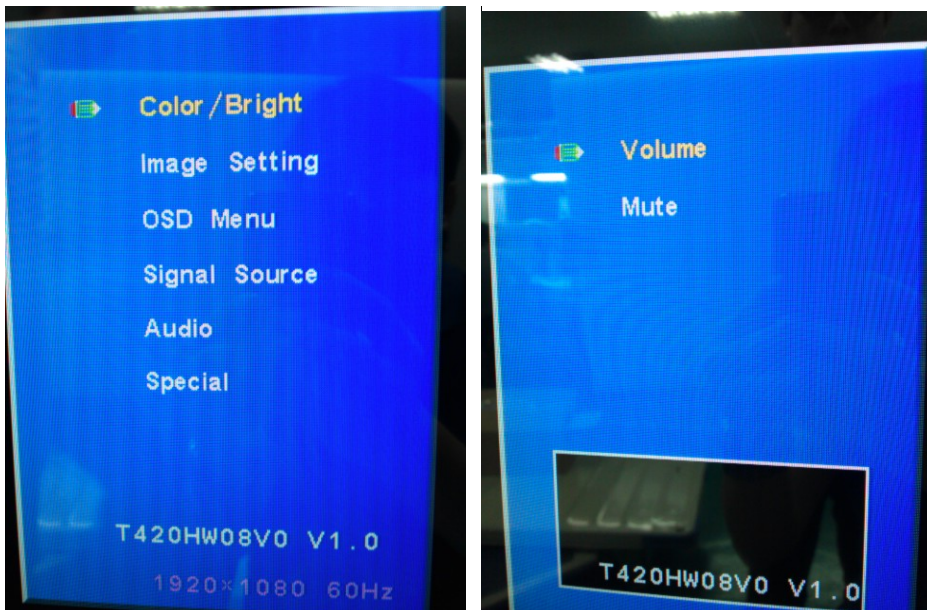

If there are speakers plugged, speaker volume can be adjusted by pressing the (▲/▼) buttons

- Volume: adjust speaker volume
- Mute: on/off speaker volume output

Special

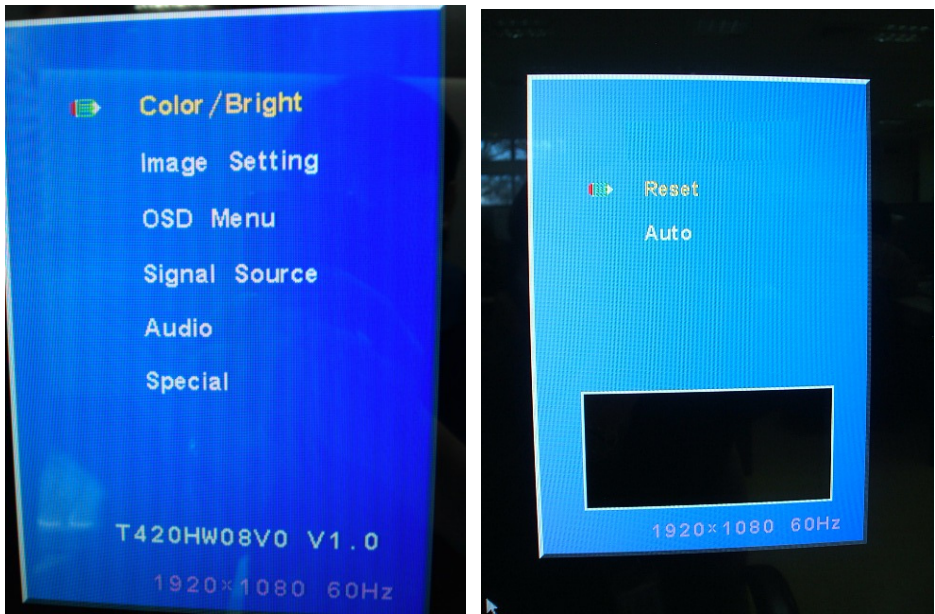

You can make OSD setting to be default or synchronize video input signals with AD board output signals.

- *Reset*: To set OSD settings to be default values
- *Auto*: To synchronize video input signals with AD board output signals to have the best LCD display quality

Summary

Color/Bright	<ul style="list-style-type: none"> ● Contrast ● Brightness ● Color adjust ● Color temp (default 9300) 	Image setting	<ul style="list-style-type: none"> ● Clock (for VGA input only) ● Phase (for VGA input only) ● Sharpness ● H position (for VGA input only) ● V position (for VGA input only)
OSD menu	<ul style="list-style-type: none"> ● OSD H position ● OSD V position ● OSD timer ● OSD language (default English) 	Signal source	<ul style="list-style-type: none"> ● D-sub1 ● D-sub2 ● DVI
Audio	<ul style="list-style-type: none"> ● Volume ● Mute 	Special	<ul style="list-style-type: none"> ● Reset ● Auto

Trouble Shooting

If your monitor fails to operate correctly, consult the following chart for possible solution before calling for repairs:

Condition	Check Point
1. The picture does not appear	<ul style="list-style-type: none"> ● Check if the signal cable is firmly seated in the socket. ● Check if the Power is ON at the computer ● Check if the brightness control is at the appropriate position, not at the minimum. ● State the monitor is powered on and the LED of power is GREEN, plug out the VGA cable and plug in again. ● Check if computer is turned on
2. The screen is not synchronized	<ul style="list-style-type: none"> ● Check if the signal cable is firmly seated in the socket. ● Check if the output level matches the input level of your computer. ● Make sure the signal timings of the computer system are within the specification of the monitor. ● If your computer was working with a CRT monitor, you should check the current signal timing and turn off your computer before you connect the VGA Cable to this monitor. ● Use the "AUTO" key on remote control to automatically adjust the display timing scan.
3. The position of the screen is not in the center	<ul style="list-style-type: none"> ● Adjust the H-position, and V-position, or perform the AUTO adjustment.
4. The screen is too bright (too dark)	<ul style="list-style-type: none"> ● Check if the brightness or contrast control is at the appropriate position, not at the Maximum (Minimum).
5. The screen is shaking or waving	<ul style="list-style-type: none"> ● Press the "AUTO" - adjustment control by remote control or OSD to adjust. Moving all objects which emit a magnetic field such as motor or transformer, away from the monitor. Check if the specific voltage is applied. ● Check if the signal timing of the computer system (or engine box) is within the specification of monitor.
6. No external sound	<ol style="list-style-type: none"> 1. Power on WMS-42PLUS3 2. Connect external speakers to lineout port 3. Set audio output to Realtek <ol style="list-style-type: none"> a. Click "Start button" b. Click "control panel", c. Click "sounds and audio devices" d. choose "Audio" sheet, check "Sound playback", set "Default device" to be "Realtek HD audio output" 4. Volume control <ol style="list-style-type: none"> a. click "Realtek HD audio manager" icon (at right bottom side) b. choose "Devices and Mixer" sheet c. The main volume can be adjusted by rotating the Playback switch

If you are unable to correct the fault by following this chart, stop using your monitor and contact your distributor or dealer for further assistance.

BIOS setup information

BIOS Introduction

The AMI BIOS (Basic Input/Output System) installed in your computer system's ROM supports Intel processors. The BIOS provides critical low-level support for a standard device such as disk drives, serial ports. It also adds virus and password protection as well as special support for detailed fine-tuning of the chipset controlling the entire system.

BIOS Setup

The AMI BIOS provides a Setup utility program for specifying the system configurations and settings. The BIOS ROM of the system stores the Setup utility. When you turn on the computer, the Award BIOS is immediately activated. Pressing the key immediately allows you to enter the Setup utility. If you are a little bit late pressing the key, POST (Power On Self Test) will continue with its test routines, thus preventing you from invoking the Setup. If you still wish to enter Setup, restart the system by pressing the "Reset" button or simultaneously pressing the <Ctrl>, <Alt> and <Delete> keys. You can also restart by turning the system Off and back On again. The following message will appear on the screen:

Press to Enter Setup

In general, you press the arrow keys to highlight items, <Enter> to select, the <PgUp> and <PgDn> keys to change entries, <F1> for help and <Esc> to quit.

When you enter the Setup utility, the Main Menu screen will appear on the screen. The Main Menu allows you to select from various setup functions and exit choices.

The section below the setup items of the Main Menu displays the control keys for this menu. At the bottom of the Main Menu just below the control keys section, there is another section, which displays information on the currently highlighted item in the list.

Note: If the system cannot boot after making and saving system changes with Setup, the Award BIOS supports an override to the CMOS settings that resets your system to its default.

Warning: It is strongly recommended that you avoid making any changes to the chipset defaults. These defaults have been carefully chosen by both Award and your system manufacturer to provide the absolute maximum performance and reliability. Changing the defaults could cause the system to become unstable and crash in some cases.

Main

AMI BIOS Setup Utility
Standard Main

System Overview		Item Help
Processor		
Intel® Core™ i5 CPU	650 3.2GHz	
Speed	3200MHz	
Count	1	
System Memory		
Size	3896MB	
System Time	[hh:mm:ss]	
System Date	[mm/dd/yyyy]	

At the bottom of the menu are the control keys for use on this menu. If you need any help in each item field, you can press the <F1> key. It will display the relevant information to help you. The memory display at the lower right-hand side of the menu is read-only. It will adjust automatically according to the memory changed. The following describes each item of this menu.

System Time

Configure system Time

Date

Configure system Date

Advanced

AMI BIOS CMOS Setup Utility Advanced

Advanced Setting	Item Help
<i>WARNING: Setting wrong values in below sections may cause system to malfunction.</i>	
CPU Configuration	
IDE Configuration	
SuperIO Configuration	
Hardware Health Configuration	
APM Configuration	
ACPI Configuration	

CPU Configuration

MPS and ACPI MADT ordering

MPS and ACPI MADT ordering. Modern ordering for Windows XP or Later OSes. Legacy ordering for Windows 2000 or earlier OSes.

Intel(R) Virtualization Tech

When enabled, a VMM can utilize the additional HW Caps. Provided by Intel(R) Virtualization Tech.
Note: A full reset is required to change the setting.

Active Processor Cores

Number of cores to enable in each processor package

A20M

Legacy OSes and APs may need A20M enabled.

Intel(R) Speed Step (TM) tech

Disable: Disable GV3
Enable: Enable GV3

Intel(R) Turbo Mode tech

Turbo mode allows processor cores to run faster than marked frequency in specific condition.

Intel(R) C-STATE tech

CState: CPU idle is set to C2/C3/C4

C State package limit setting

Selected option will program into C State package limit register.

IDE Configuration

Configure SATA as

IDE, RAID, AHCI, Disabled

SATA#1 IDE configuration

Compatible, Enhanced.

SATA#2 IDE configuration

Disabled, Enhanced.

Primary IDE Master

Type

Select the type of device connected to the system.

LBA/Large Mode

Disabled: Disables LBA Mode.

Auto: Enables LBA Mode if the device supports it and the device is not already formatted with LBA Mode disabled.

Block (Multi-Sector Transfer)

*Disabled: The Data transfer from and to the device occurs one sector at a time.
Auto: The Data transfer from and to the device occurs multiple sectors at a time if the device supports it.*

PIO Mode

Select PIO Mode

DMA Mode

Select DMA Mode

Auto: Auto detected

SWDMAn: Single Word DMAn

MWDMAn: Multi Word DMAn

UDMAn: Ultra DMAn

S.M.A.R.T.

S.M.A.R.T. stands for Self-Monitoring, Analysis and Reporting Analysis and Reporting Technology.

32Bit Data Transfer

Enable/Disable 32Bit Data Transfer

Primary IDE Slave

Type

Select the type of device connected to the system.

LBA/Large Mode

Disabled: Disables LBA Mode.

Auto: Enables :BA Mode if the device supports it and the device is not already formatted with LBA Mode disabled.

Block (Multi-Sector Transfer)

Disabled: The Data transfer from and to the device occurs one sector at a time.

Auto: The Data transfer from and to the device occurs multiple sectors at a time if the device supports it.

PIO Mode

Select PIO Mode

DMA Mode

Select DMA Mode

Auto: Auto detected

SWDMAn: Single Word DMAn

MWDMAn: Multi Word DMAn

UDMAn: Ultra DMAn

S.M.A.R.T.

S.M.A.R.T. stands for Self-Monitoring, Analysis and Reporting Analysis and Reporting Technology.

32Bit Data Transfer

Enable/Disable 32Bit Data Transfer

Secondary IDE Master

Type

Select the type of device connected to the system.

LBA/Large Mode

Disabled: Disables LBA Mode.

Auto: Enables :BA Mode if the device supports it and the device is not already formatted with LBA Mode disabled.

Block (Multi-Sector Transfer)

Disabled: The Data transfer from and to the device occurs one sector at a time.

Auto: The Data transfer from and to the device occurs multiple sectors at a time if the device supports it.

PIO Mode

Select PIO Mode

DMA Mode

Select DMA Mode

Auto: Auto detected

SWDMAn: Single Word DMAn

MWDMAn: Multi Word DMAn

UDMAn: Ultra DMAn

S.M.A.R.T.

S.M.A.R.T. stands for Self-Monitoring, Analysis and Reporting Analysis and Reporting Technology.

32Bit Data Transfer

Enable/Disable 32Bit Data Transfer

Secondary IDE Slave

Type

Select the type of device connected to the system.

LBA/Large Mode

Disabled: Disables LBA Mode.

Auto: Enables LBA Mode if the device supports it and the device is not already formatted with LBA Mode disabled.

Block (Multi-Sector Transfer)

Disabled: The Data transfer from and to the device occurs one sector at a time.

Auto: The Data transfer from and to the device occurs multiple sectors at a time if the device supports it.

PIO Mode

Select PIO Mode

DMA Mode

Select DMA Mode

Auto: Auto detected

SWDMAn: Single Word DMAn

MWDMAn: Multi Word DMAn

UDMAn: Ultra DMAn

S.M.A.R.T.

S.M.A.R.T. stands for Self-Monitoring, Analysis and Reporting Analysis and Reporting Technology.

32Bit Data Transfer

Enable/Disable 32Bit Data Transfer

Hard Disk Write Protect

Disable/Enable device write protection. This will be effective only if device is accessed through BIOS.

IDE Detect Time Out (Sec)

Select the out value for detecting ATA/ATAPI device(s).

Super IO Configuration

Serial Port1 Address

Allows BIOS to Select Serial Port1 Base Addresses.

Hardware Health Configuration

CPUFAN Mode Setting

Fan configuration mode setting

SYSFAN0 Mode Setting

Fan configuration mode setting

APM Configuration

Power Management/APM

Enable or disable APM.

Resume On RTC Alarm

Disable/Enable RTC to generate a wake event

ACPI Configuration

General ACPI Configuration

Suspend mode

Select the ACPI state used for System Suspend.

Repost Video on S3 Resume

Determines whether to invoke VGA BIOS post on S3/STR

Advanced ACPI Configuration

ACPI Version Features

Enable RSDP pointers to 64-bit Fixed System Description Tables. Di ACPI version has some.

ACPI APIC support

Include ACPI APIC table pointer to RSDT pointer list

AMI OEMB table

Include OEMB table pointer to R(X)SDT pointer list

Headless mode

Enable/ Disable Headless operation mode through ACPI

Chipset ACPI Configuration

APIC ACPI SCI IRQ

Enable/Disable APIC ACPI SCI IRQ

High Performance Event Timer

Enable/Disable APIC ACPI SCI IRQ

Boot

AMI BIOS CMOS Setup Utility Boot

Boot Setting	ITEM HELP
Boot Settings Configuration	
Boot Device Priority	
Hard Disk Drives	

Boot Settings Configuration

Quick Boot

Allows BIOS to skip certain tests while booting. This will decrease the time needed to boot the system.

Quiet Boot

Disabled: Displays normal POST messages

Enable: Displays OEM Logo instead of POST messages.

Add On ROM Display Mode

Set display mode for Option ROM

Boot up Num-Lock

Select Power-on state for Numlock.

PS/2 Mouse Support

Select support for PS/2 Mouse

Wait For "F1" If Error

Wait for F1 key to be pressed if error occurs

Hit "DEL" Message Display

Displays "Press Del to run Setup" in POST

Interrupt 19 Capture

Enabled: Allows option ROMs to trap interrupt 19

Boot Device Priority

1st Boot Device

Specifies the boot sequence from the available devices.

A device enclosed in parenthesis has been disabled in the corresponding type menu.

2nd Boot Device

Specifies the boot sequence from the available devices.

A device enclosed in parenthesis has been disabled in the corresponding type menu.

Hard Disk Drives

1st Drive

Specifies the boot sequence from the available devices.

Security Setting

AMI BIOS CMOS Setup Utility Security Setting

Security Setting	ITEM HELP
<i>Change Supervisor Password</i>	
<i>Change User Password</i>	
<i>Boot Sector Virus Protection</i>	

Change Supervisor Password

Install or Change the password.

Change User Password

Install or Change the password.

Boot Sector Virus Protection

Enable/Disable Boot Sector Virus Protection.

Power Management Setup

Phoenix - AwardBIOS CMOS Setup Utility
Power Management Setup

Advanced Chipset Settings	ITEM HELP
North Bridge Configuration	
South Bridge Configuration	

North Bridge Configuration

Memory Remap Feature

ENABLE: Allow remapping of overlapped PCI memory above the total physical memory.

DISABLE: Do not allow remapping of memory.

DRAM Frequency

Auto, 800, 1067, 1333, 1600

Configure DRAM Timing by SPD

Auto, Manual

Memory Hole

Disabled, 15MB-16MB

DRAM Margin Ranks

Disabled, Enabled

Hybrid Multi-Monitor

Allowing for operability of IGD and PEG independently-driven displays

Initiate Graphic Adapter

Select which Graphics controller to use as the primary boot device.

IGD Graphics Mode Select

Select the amount of system memory used by the Internal graphics device.

PEG Port

Auto, Disabled

Video Function Configuration

DVMT Mode Select

DVNT/FIXED Memory

South Bridge Configuration

USB Function

Enable/Disable USB controller in system.

EHCI Controller#1

Enable Intergraded USB 2.0 RMH#1

EHCI Controller#2

Enable Intergraded USB 2.0 RMH#2

HAD Controller

Enabled, Disabled

Restore on AC Power Loss

Power Off, Power On, Last State

Exit Option

AMI BIOS CMOS Setup Utility Exit Option

<i>Exit Option</i>	<i>ITEM HELP</i>
<i>Save Changes and Exit</i> <i>Discard Changes and Exit</i> <i>Discard Changes</i> <i>Load Optimal Defaults</i> <i>Load Failsafe Defaults</i>	

Save Changes and Exit

Exit system setup after saving the changes.

Discard Changes and Exit

Exit system setup without saving any changes.

Discard Changes

Discards changes done so far to any of the setup questions.

Load Optimal Defaults

Load Optimal Default values for all the setup questions.

Load Failsafe Defaults

Load Failsafe Default values for all the setup questions..

Appendix

A. Jumper settings and Connectors

Note: Some of jumpers or connectors will be removed base on system configuration.

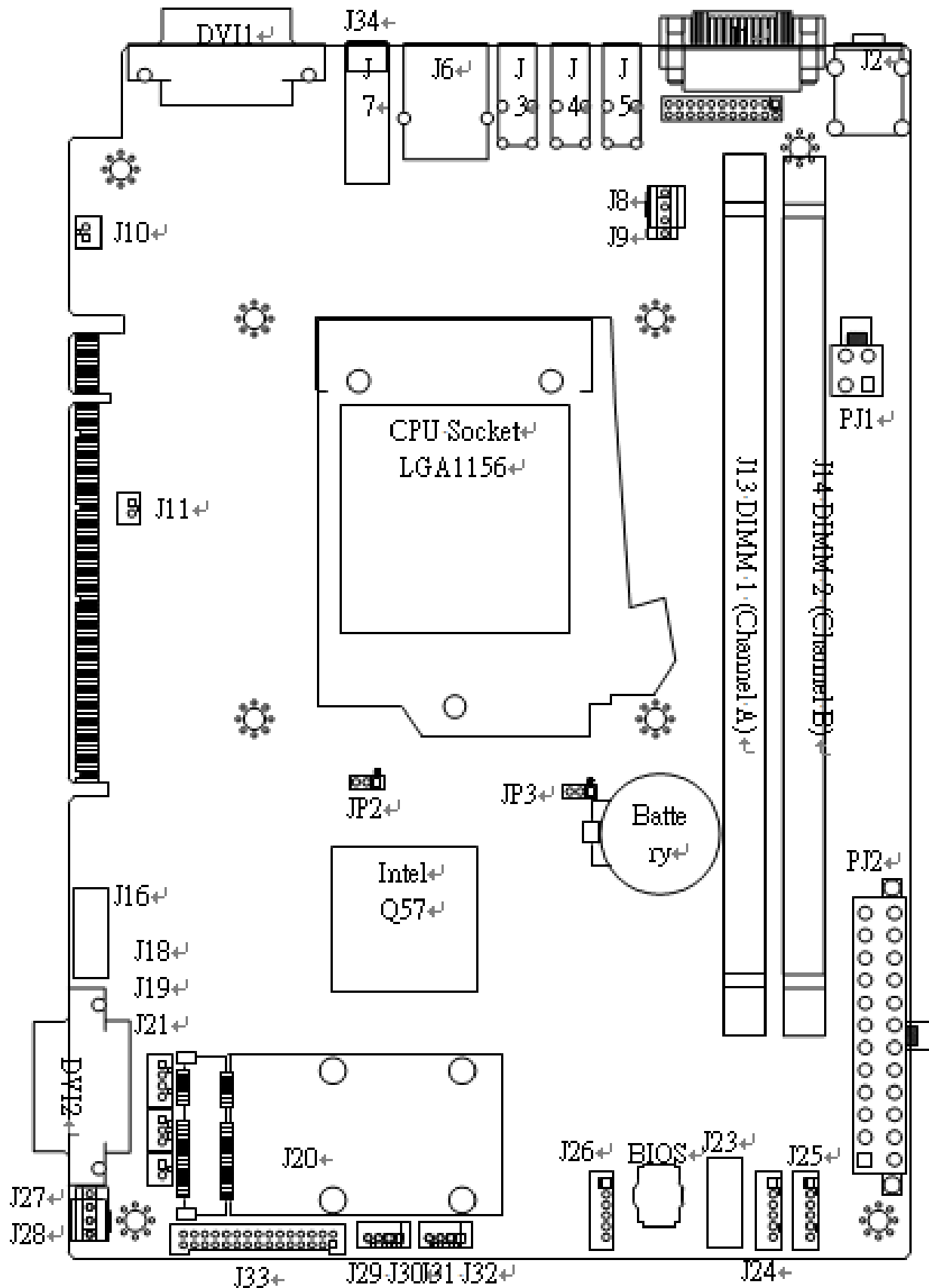

JP1-COM1 Function Selection

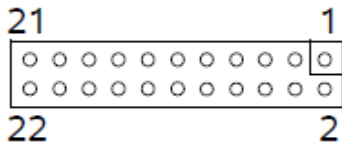

Description	Jumper Setting
RS-232	5-6, 9-11, 10-12, 15-17, 16-18
RS-422	3-4, 7-9, 8-10, 13-15, 14-16, 21-22
RS-485	1-2, 7-9, 8-10, 19-20

JP2-PCI Express x16 Static Lane Numbering Reversal

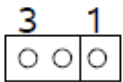

Description	Jumper Setting
No Reversal (for WPE)	1-2
Reversal (WMS)	2-3

JP3-Clear CMOS

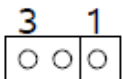

Description	Jumper Setting
Normal	1-2
CMOS Cleared	2-3

DVI1-External DVI-I Interface

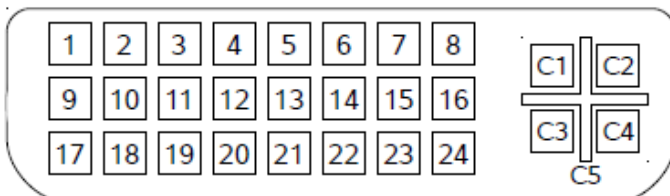

Pin #	Signal Description	Pin #	Signal Description
1	TMDS Data2-	2	TMDS Data+
3	TMDS Data2 Shield	4	NC

Pin #	Signal Description	Pin #	Signal Description
5	NC	6	DDC Clock
7	DDC Data	8	Analog Vertical
9	TMDS Data1-	10	TMDS Data1+
11	TMDS Data1 Shield	12	NC
13	NC	14	+5V
15	GND	16	Hot Plug Detect
17	TMDS Data0-	18	TMDS Data0+
19	TMDS Data0 Shield	20	NC
21	NC	22	TMDS Clock Shield
23	TMDS Clock+	24	TMDS Clock-
C1	Analog Red	C2	Analog Green
C3	Analog Blue	C4	Analog Horizontal
C5	Analog GND		

DVI2-Internal DVI-D Interface

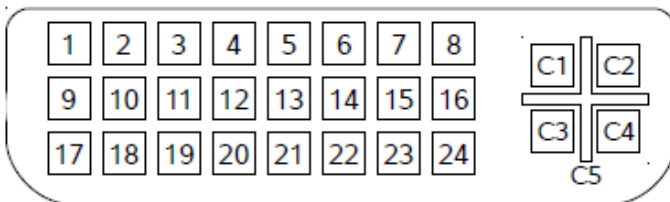

Pin #	Signal Description	Pin #	Signal Description
1	TMDS Data2-	2	TMDS Data+
3	TMDS Data2 Shield	4	NC
5	NC	6	DDC Clock
7	DDC Data	8	NC
9	TMDS Data1-	10	TMDS Data1+
11	TMDS Data1 Shield	12	NC
13	NC	14	+5V
15	GND	16	Hot Plug Detect
17	TMDS Data0-	18	TMDS Data0+
19	TMDS Data0 Shield	20	NC
21	NC	22	TMDS Clock Shield
23	TMDS Clock+	24	TMDS Clock-
C1	NC	C2	NC
C3	NC	C4	NC
C5	NC		

J1-COM port 1(RS-232/RS-422/RS-485)

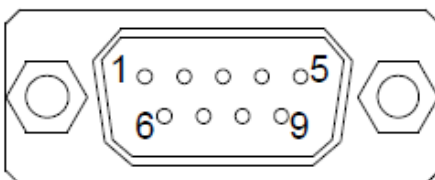

Pin#	Signal Description		
	RS-232	RS-422	RS-485
1	Carrier Detect	Transmit Data -	Transmit Data -
2	Receive Data	Transmit Data +	Transmit Data +
3	Transmit Data	Receive Data +	N/A
4	Data Terminal Ready	Receive Data -	N/A
5	Ground	Ground	Ground
6	Data Set Ready	N/A	N/A
7	Request to Send	N/A	N/A
8	Clear to Send	N/A	N/A
9	Ring Indicator	N/A	N/A

J2-Audio

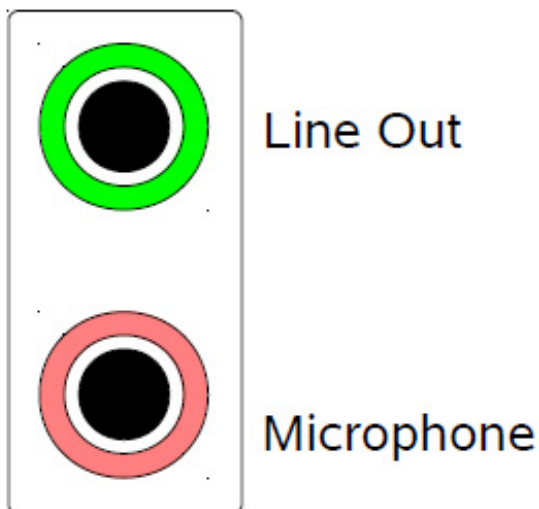

J3,J4,J5-USB Connector

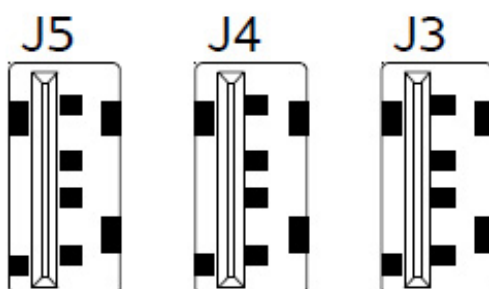

J6-Ethernet Port

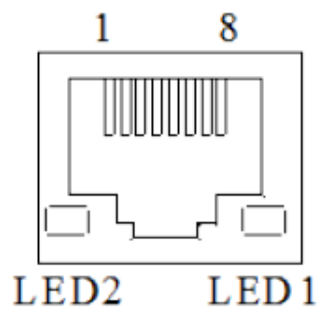

Pin#	Description
1	Data0+
2	Data0-
3	Data1+
4	Data2+
5	Data2-
6	Data1-
7	Data3+
8	Data3-
LED1	LINK/ACTIVE LED
LED2	SPEED LED

J7-HDMI

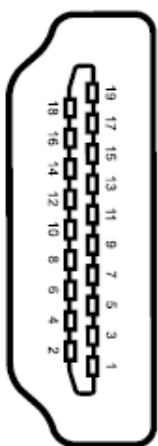

Pin#	Description
1	Data0+

Pin#	Description
2	Data0-
3	Data1+
4	Data2+
5	Data2-
6	Data1-
7	Data3+
8	Data3-
LED1	LINK/ACTIVE LED
LED2	SPEED LED

J8,J9-CPU FAN

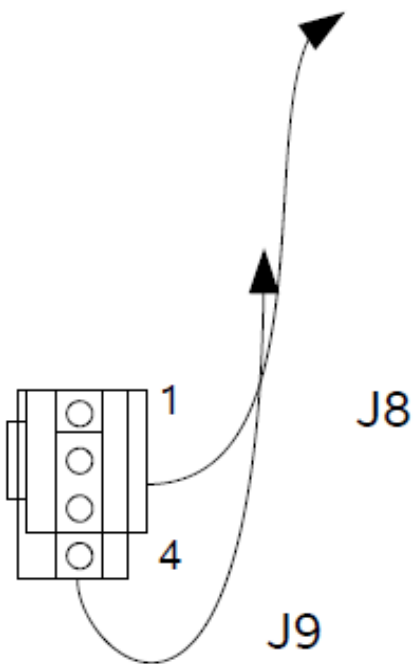

Pin#	Description	Mode	
1	Ground	J8 DC mode	J9 PWM mode
2	VCC (0~12V)		
3	Fan Speed detection		
4	Fan speed Control		

J10,J21-Power Button

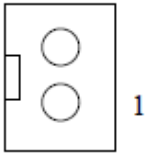

Pin#	Description
1	+5V
2	Power On

J11-External AUX Thermal Detection I/F

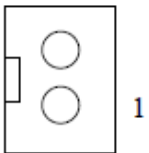

Pin#	Description
1	Thermal +
2	Thermal -

J16,J23-SATA Connector

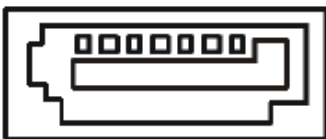

J17-Debug Port (For debug only)

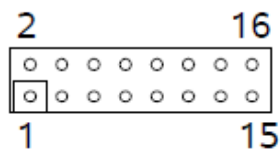

Pin#	Description	Pin#	Description
1	LPC DATA0	2	RESET#
3	LPC DATA1	4	NC
5	LPC DATA2	6	+3.3V

Pin#	Description	Pin#	Description
7	LPC DATA3	8	+5V
9	LPC FRAME#	10	NC
11	LPC CLOCK	12	NC
13	Ground	14	NC
15	NC	16	NC

J18-Power/HDD Indicator



Pin#	Description
1	HDD Active Indicator
2	+5V
3	+5V
4	Power indicator

J19-Reset Button



Pin#	Description
1	RESET#
2	Ground
3	Ground

J20-Mini PCI Express Socket

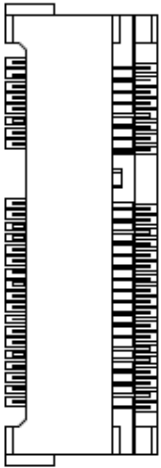

J24,J25-Internal USB Connector

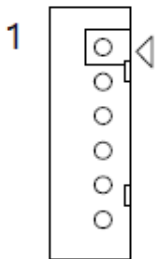

Pin#	Description
1	+5V
2	+5V
3	USB-
4	USB+
5	Ground
6	Ground

J26-PS/2 Keyboard,Mouse

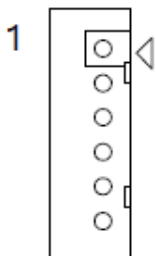

Pin#	Description
1	KB data
2	MS data

Pin#	Description
3	Ground
4	+5V
5	KB clock
6	MS clock

J27,J28-AUX FAN

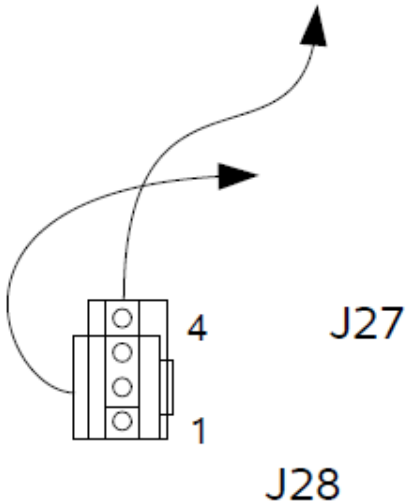

Pin#	Description	Mode	
1	Ground	J27 DC mode	J28 PWM mode
2	VCC (0~12V)		
3	Fan Speed detection		
4	Fan speed Control		

J29,J30,J31,J32-System FAN

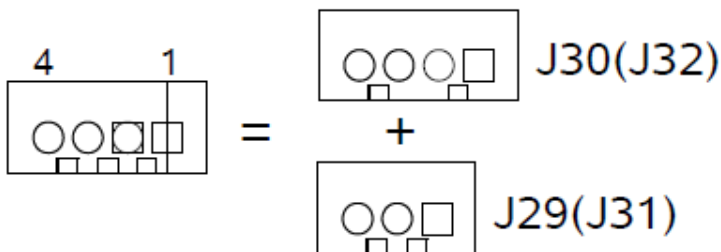

Pin#	Description	Mode	
1	Fan speed Control	J29,J31 DC mode	J30,J32 PWM mode
2	Fan Speed detection		
3	VCC(0~12V)		

Pin#	Description	Mode
4	Ground	

J33-Expansion Connector for WMS series

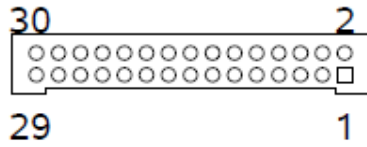

Pin#	Description	Pin#	Description
COM Port 2			
1	Carrier Detect	2	Data Set Ready
3	Receive Data	4	Request to Send
5	Transmit Data	6	Clear to Send
7	Data Terminal Ready	8	Ring Indicator
9	Ground	10	Ground
USB			
11	Expand USB OC#	12	Expand USB Port 1-
13	Ground	14	Expand USB Port 1+
15	SUSC#	16	Expand USB Port 2-
Fan		18	Expand USB Port 2+
17	AUX Fan speed Control	20	AUX Fan VCC
19	AUX Fan Speed detection	22	NC
21	SMBus Clock	24	Ground
23	SMBus Data	Audio Speaker Out	
25	System Reset#	26	Speaker Out Left
27	Power On#	28	Speaker Out Right
29	Jacke Plug-In detetction	30	Audio Ground

J34-Reset Button

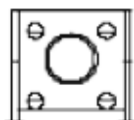

PJ1-CPU ATX-12V

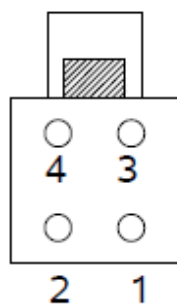

Pin#	Description
1	Ground
2	Ground
3	+12V
4	+12V

PJ2-ATX24 Power Connector

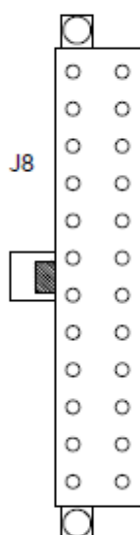

Pin#	Description
1	Ground
2	Voltage(0~+12V)
3	Fan RPM Signal

B. Wake UP on LAN Function

Please make sure the AC power is ON before use the function.

1. Boot into OS (windows XP).
2. In start menu control panel System device manager Network adapters double click Marvell Yukon 88E8071 Advance Wake from Shutdown Item select Wake on Magic packet from power off state.

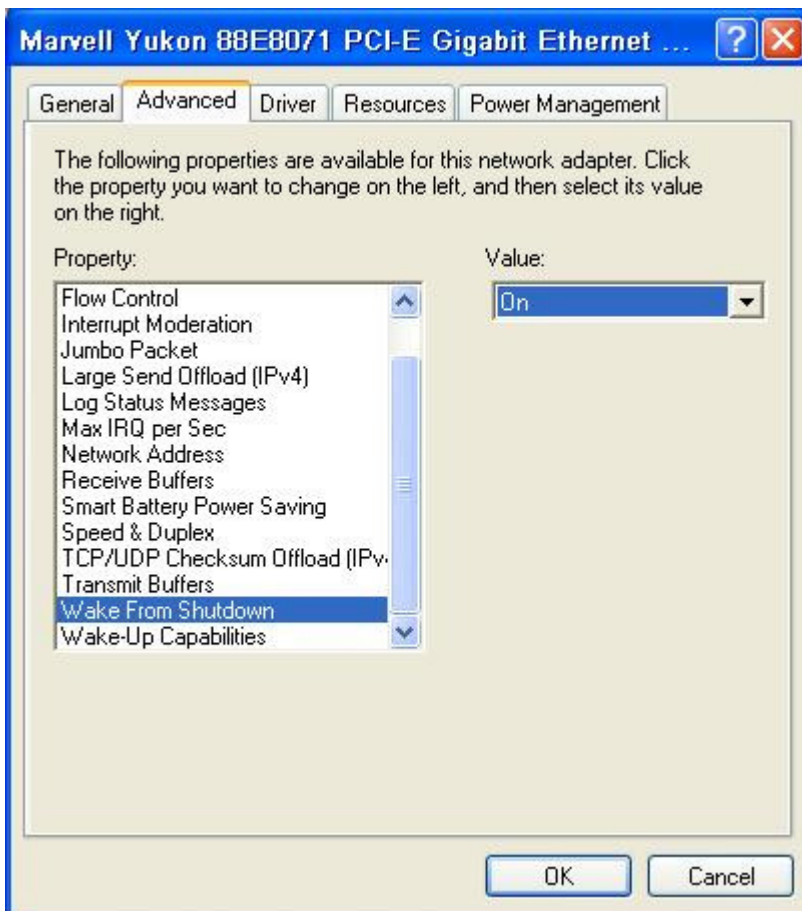

Please shutdown system and wait for wake on LAN after finish these procedures.