

**WP25051T5**

## Description

The WP25051T5 are current limited P-channel MOSFET power switch designed for high-side load switching applications. This switch operates with inputs ranging from 2.5V to 5.5V, making it ideal for both 3.3V and 5V systems. An integrated current-limiting circuit protects the input supply against large currents which may cause the supply to fall out of regulation. The WP25051T5 is also protected from thermal overload which limits power dissipation and junction temperatures. Current limit threshold is fixed internally. The quiescent supply current in active mode is only 25 $\mu$ A. In shutdown mode, the supply current decreases to less than 1 $\mu$ A.

The WP25051T5 is available in Pb-free packages and is specified over the -40°C to +85°C ambient temperature range.

## Features

- Input Voltage Range: 2.5V to 5.5V
- Fixed Current Limit
- Reverse Current Blocking
- Short-Circuit Response: 2 $\mu$ s
- Very Low Quiescent Current: 25 $\mu$ A (Typ)
- 1 $\mu$ A Max Shutdown Supply Current
- Under-Voltage Lockout
- Thermal Shutdown
- 4kV ESD Rating
- Package: SOT23-5
- Ambient Temperature Range: -40°C to +85°C

## Applications

- 3G Wireless Cards
- Smart Phones and PDAs
- LCD TVs and Monitors
- Set-Top-Boxes
- MP3/MP4
- Printers
- Portable Game Players
- Portable Media Players and MIDs
- USB Keyboards
- USB Hard Disk Drives
- USB Memory Drives
- USB Hubs

## Pin Configuration

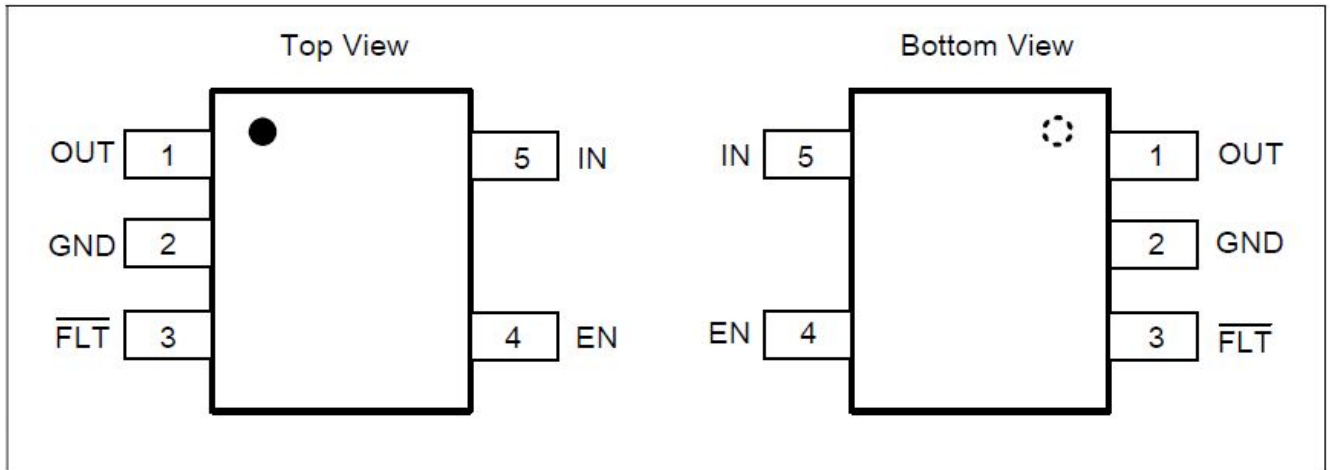

### Pin Function

Pin Name	Pin Number	Pin Function
OUT	1	Power output.
GND	2	Ground Pin.
$\overline{\text{FLT}}$	3	Overcurrent and over-temperature fault reporting signal output, active low with 6ms blanking time for overcurrent conditions.
EN	4	Enable input, high enable.
IN	5	Power supply input.

### Absolute Maximum Ratings

Parameter	Rating	Unit
IN, EN, $\overline{\text{FLT}}$ Voltage	-0.3 to 6	V
OUT Voltage	-0.3 to $V_{\text{IN}} + 0.3$	V
OUT Current	Internal Limited	A
Power Dissipation	300	mW
Package Thermal Resistance( $\theta_{\text{JA}}$ )	250	$^{\circ}\text{C}/\text{W}$
Operating Junction Temperature	-40 to 125	$^{\circ}\text{C}$
Storage Temperature	-55 to 150	$^{\circ}\text{C}$
Lead Temperature (Soldering, 10 sec)	300	$^{\circ}\text{C}$

### Electrical Characteristics

(VIN = +5.0V, TA = -40°C to 85°C, typical values at TA=25°C, unless otherwise stated)

Symbol	Parameter	Test Conditions	Min	Typ.	Max	Unit
V <sub>IN</sub>	Input Voltage Range		2.5		5.5	V
V <sub>UVLO</sub>	Input UVLO		1.4	1.8	2.2	V
I <sub>SHDN</sub>	Input Shutdown Quiescent Current	Disabled, V <sub>EN</sub> =0V, OUT floating or shorted to ground		0.1	1	μA
I <sub>Q</sub>	Input Quiescent Current /Channel	Enabled, V <sub>EN</sub> =V <sub>IN</sub> , I <sub>OUT</sub> = 0		25	60	μA
R <sub>DS(ON)</sub>	Switch on-resistance	V <sub>IN</sub> =5V, I <sub>OUT</sub> =0.6A		80	120	mΩ
I <sub>LMT</sub>	Current Limit	V <sub>IN</sub> =5V, V <sub>OUT</sub> =4.5V	0.6	0.85	1.2	A
V <sub>IL</sub>	EN Input Logic Low Voltage				0.8	V
V <sub>IH</sub>	EN Input Logic High Voltage		2			V
I <sub>SINK</sub>	EN Input leakage	V <sub>EN</sub> = 5V		0.01	1	μA
T <sub>D(ON)</sub>	Output Turn-on Delay Time	V <sub>IN</sub> =5V, C <sub>L</sub> =1μF, R <sub>LOAD</sub> =100Ω	0.5	0.9	1.3	ms
T <sub>R</sub>	Output Turn-on Rise Time	V <sub>IN</sub> =5V, C <sub>L</sub> =1μF, R <sub>LOAD</sub> =100Ω	0.3	0.5	0.7	ms
T <sub>D(OFF)</sub>	Output Turn-off Delay Time	V <sub>IN</sub> =5V, C <sub>L</sub> =1μF, R <sub>LOAD</sub> =100Ω	0.1	0.5	0.9	ms
T <sub>F</sub>	Output Turn-off Fall Time	V <sub>IN</sub> =5V, C <sub>L</sub> =1μF, R <sub>LOAD</sub> =100Ω	50	230	400	μs
T <sub>FLT_BLANK</sub>	FLT Blanking Time		2	6	10	ms
V <sub>FLT_Lo</sub>	FLT Logic Low Voltage	I <sub>FLT(SINK)</sub> =1mA			0.2	V
I <sub>FLT</sub>	FLT Leakage Current	V <sub>FLT</sub> = 5V, Enabled, No Fault Conditions		0.1	1	μA
R <sub>discharge</sub>	Output discharge FET R <sub>dson</sub>	V <sub>IN</sub> = 5V, EN=0V, V <sub>OUT</sub> =5V	200	400	800	Ω
I <sub>REV</sub>	Rverse leakage current	V <sub>OUT</sub> = 5V , V <sub>IN</sub> =0V measure I <sub>VOUT</sub>		0.2	2	μA
T <sub>SHDN</sub>	Thermal shutdown threshold	V <sub>IN</sub> = 5V	120	135	155	°C
T <sub>HYS</sub>	Thermal shutdown hysteresis	V <sub>IN</sub> = 5V		15		°C

## Block Diagram

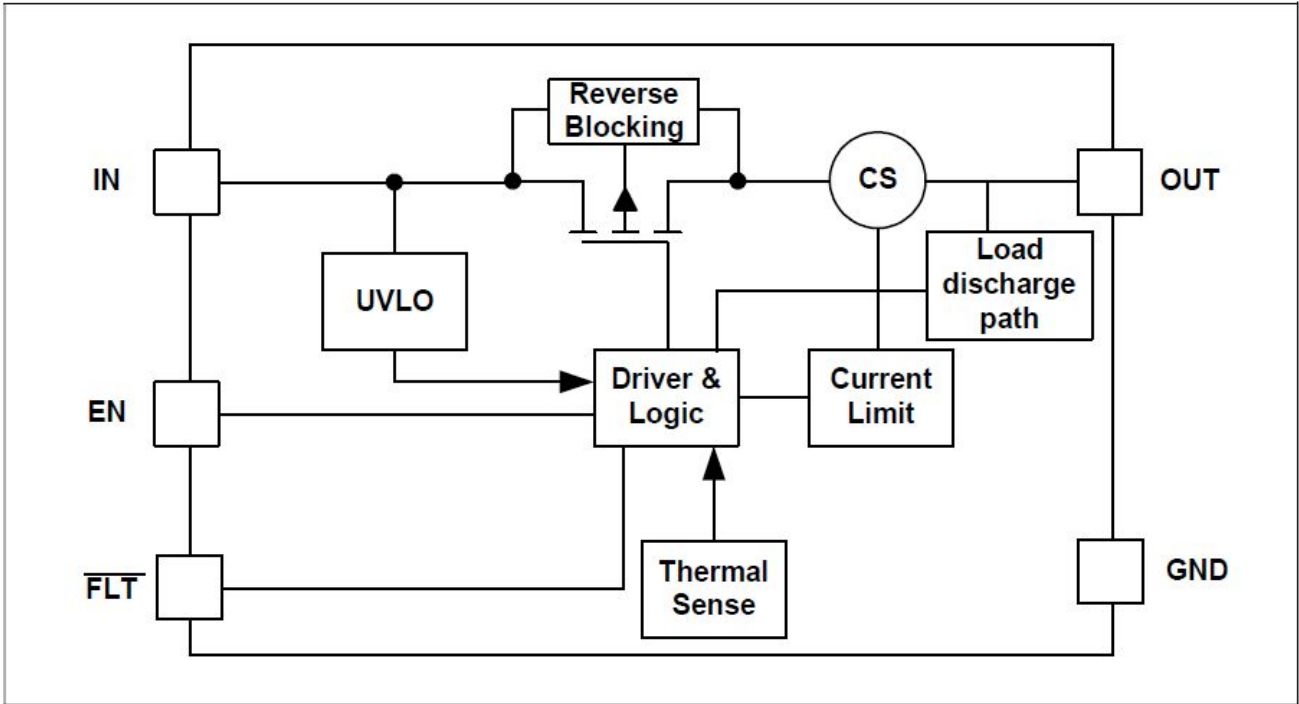

### Typical Performance Characteristics

UVLO at Rising

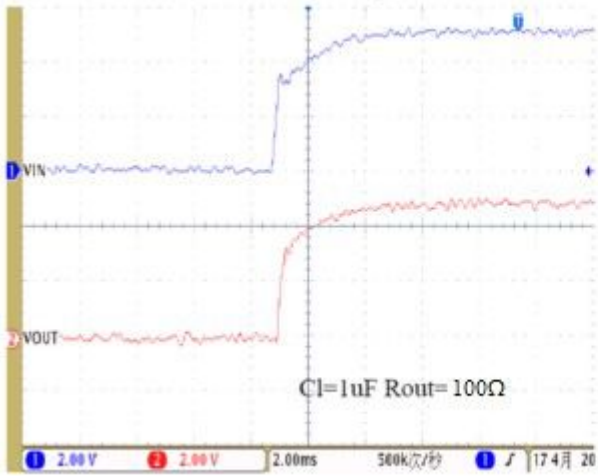

UVLO at Falling

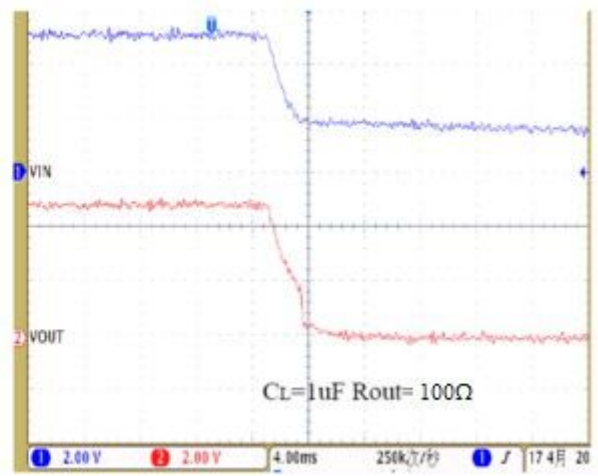

### Over Load Response VS Vout

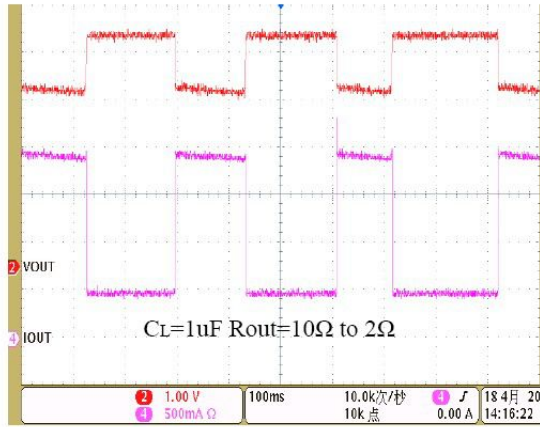

### Short Circuit Response and Thermal Shut Down

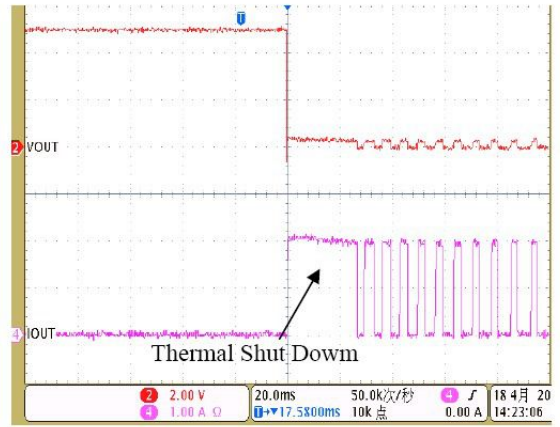

### Over Load Response VS FLT

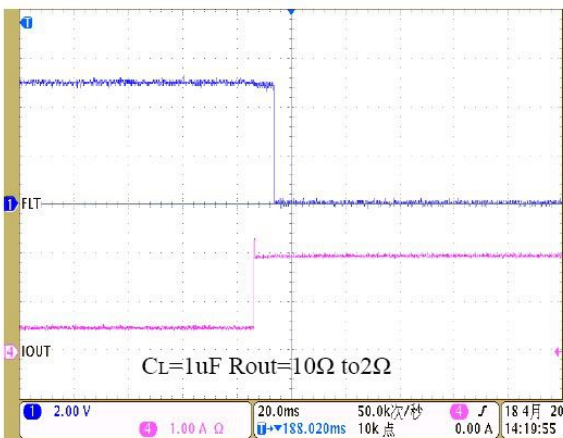

### Turnoff Delay and Fall time

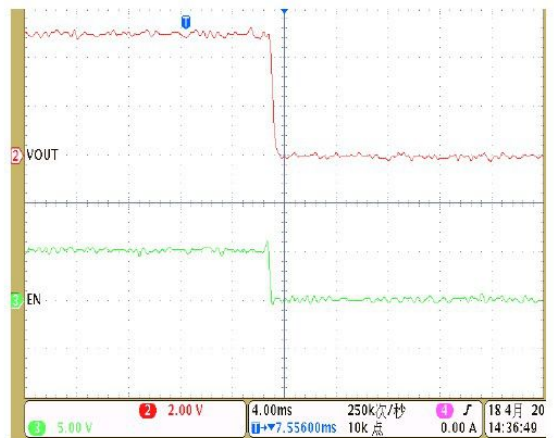

### Turnon Delay and Output Response

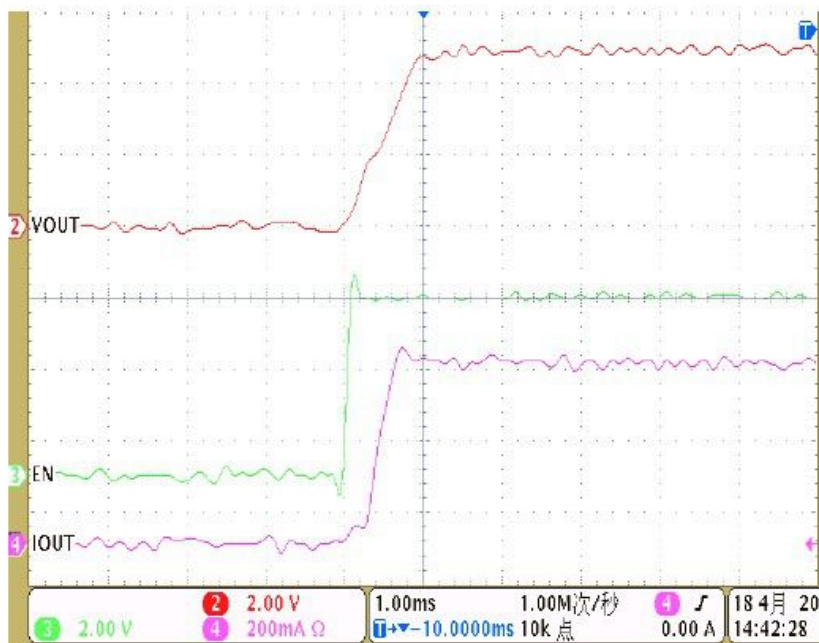

## Application Circuits

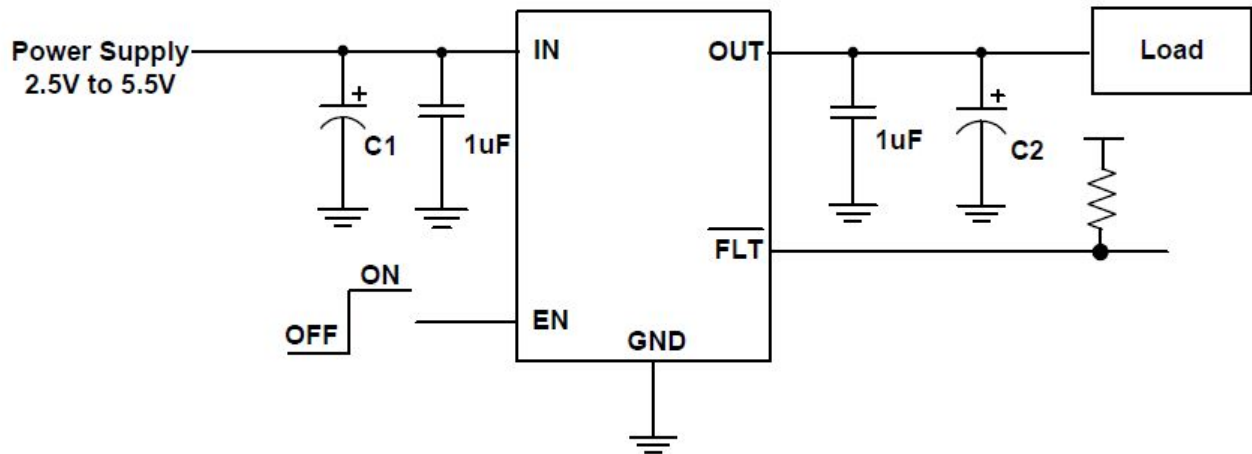

Note: Tantalum or Aluminum Electrolytic capacitors (C1 and C2) may be required for USB applications

## Package

