

128Kx32 SRAM MODULE, SMD 5962-93187 & 5962-95595

FEATURES

- Access Times of 15, 17, 20, 25, 35, 45, 55ns
- MIL-STD-883 Compliant Devices Available
- Packaging
 - 66 pin, PGA Type, 1.075" square, Hermetic Ceramic HIP (Package 400)
 - 68 lead, 40mm CQFP (G4T)¹, 3.56mm (0.140") (Package 502)
 - 68 lead, 22.4mm CQFP (G2U), 3.56mm (0.140"), (Package 510)
 - 68 lead, 22.4mm (0.880") square, CQFP (G2L), 5.08mm (0.200") high, (Package 528)
- Organized as 128Kx32; User Configurable as 256Kx16 or 512Kx8
- Commercial, Industrial and Military Temperature Ranges
- 5 Volt Power Supply
- Low Power CMOS
- TTL Compatible Inputs and Outputs
- Built in Decoupling Caps and Multiple Ground Pins for Low Noise Operation
- Weight:
 - WS128K32-XG2UX - 8 grams typical
 - WS128K32-XG2LX - 8 grams typical
 - WS128K32-XH1X - 13 grams typical
 - WS128K32-XG4TX¹ - 20 grams typical
- Devices are upgradeable to 512Kx32

This product is subject to change without notice.

FIGURE 1 – PIN CONFIGURATION FOR WS128K32N-XH1X

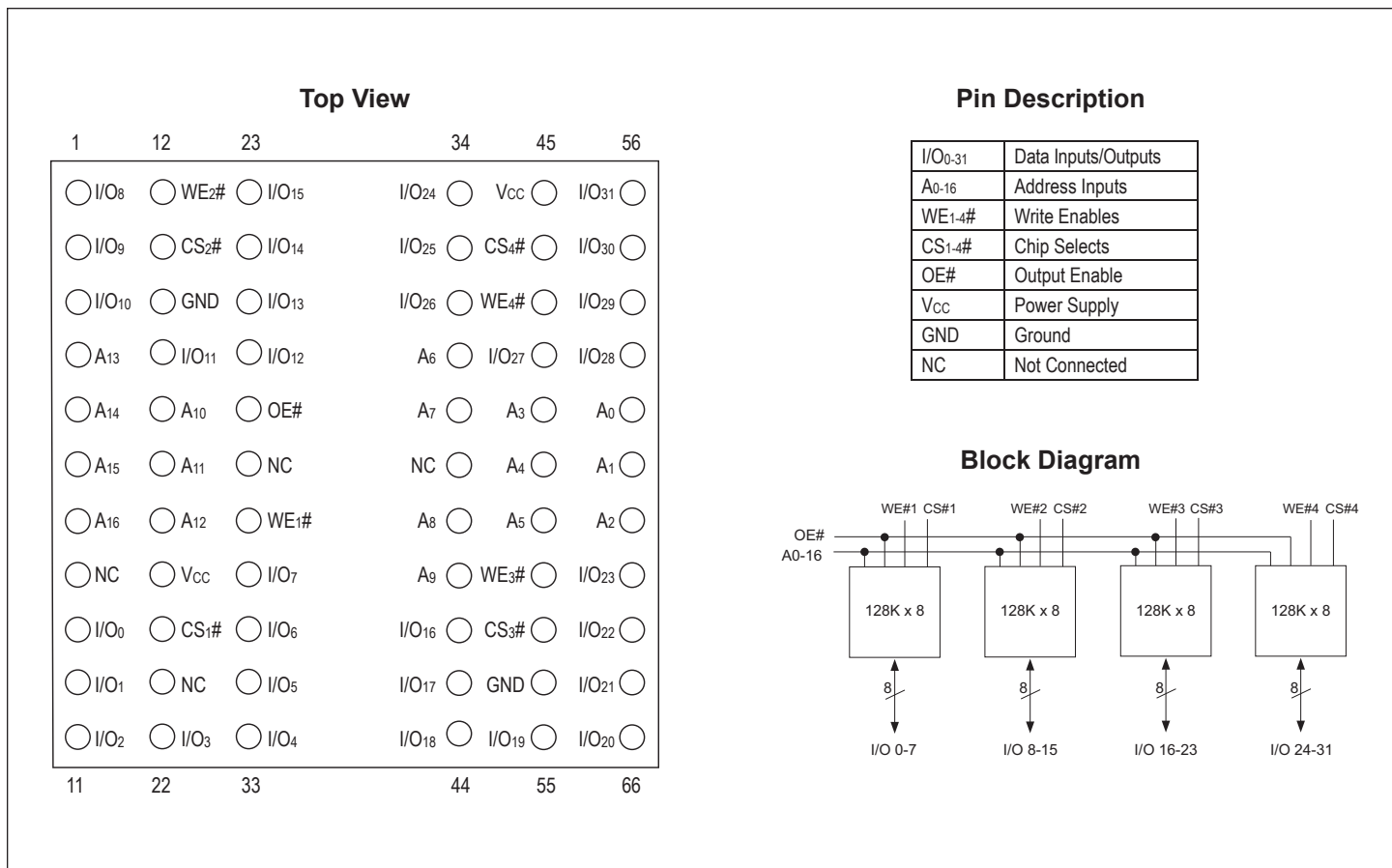
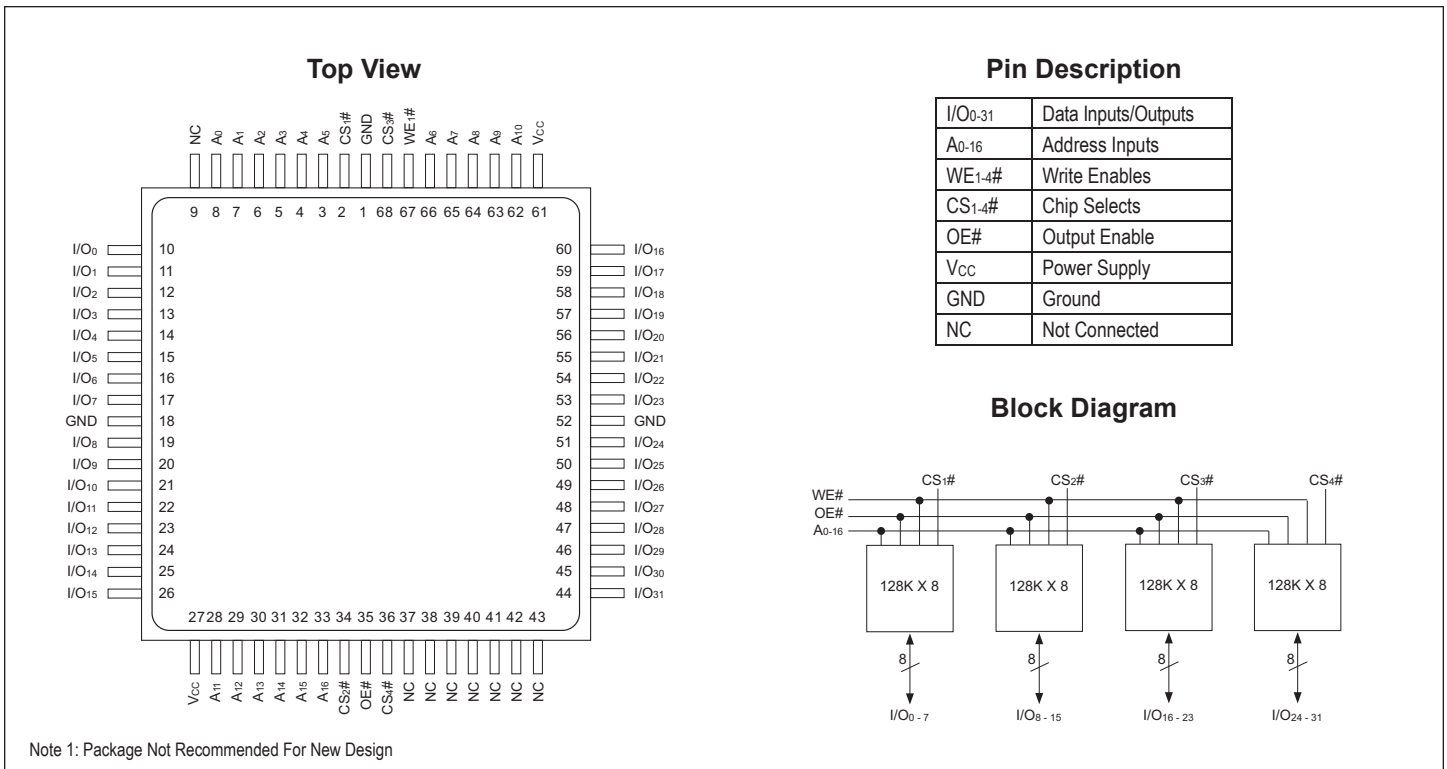
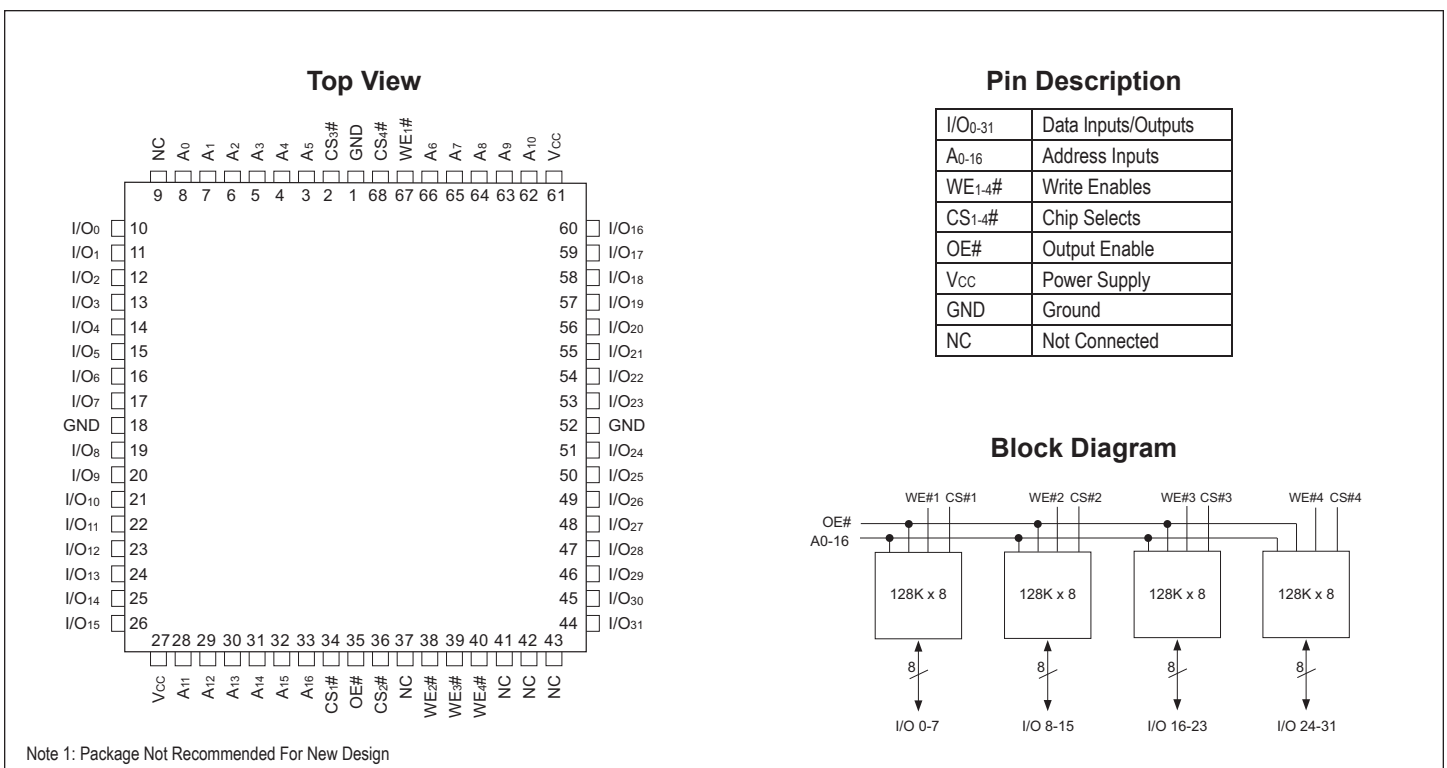

FIGURE 2 – PIN CONFIGURATION FOR WS128K32-XG4TX¹

FIGURE 3 – PIN CONFIGURATION FOR WS128K32-XG2UX AND WS128K32-XG2LX

ABSOLUTE MAXIMUM RATINGS

Parameter	Symbol	Min	Max	Unit
Operating Temperature	T _A	-55	+125	°C
Storage Temperature	T _{STG}	-65	+150	°C
Signal Voltage Relative to GND	V _G	-0.5	V _{CC} +0.5	V
Junction Temperature	T _J		150	°C
Supply Voltage	V _{CC}	-0.5	7.0	V

TRUTH TABLE

CS	OE	WE	Mode	Data I/O	Power
H	X	X	Standby	High Z	Standby
L	L	H	Read	Data Out	Active
L	X	L	Write	Data In	Active
L	H	H	Out Disable	High Z	Active

RECOMMENDED OPERATING CONDITIONS

Parameter	Symbol	Min	Max	Unit
Supply Voltage	V _{CC}	4.5	5.5	V
Input High Voltage	V _{IH}	2.2	V _{CC} + 0.3	V
Input Low Voltage	V _{IL}	-0.5	+0.8	V
Operating Temp (Mil)	T _A	-55	+125	°C

CAPACITANCE

 T_A = +25°C

Parameter	Symbol	Conditions	Max	Unit
OE# capacitance	C _{OE}	V _{IN} = 0V, f = 1.0 MHz	50	pF
WE1-4# capacitance	C _{WE}	V _{IN} = 0V, f = 1.0 MHz	20	pF
HIP (PGA) H1				
CQFP G4T				
CQFP G2U/G2L				
CS1-4# capacitance	C _{CS}	V _{IN} = 0V, f = 1.0 MHz	20	pF
Data# I/O capacitance	C _{I/O}	V _{I/O} = 0V, f = 1.0 MHz	20	pF
Address input capacitance	C _{AD}	V _{IN} = 0V, f = 1.0 MHz	50	pF

This parameter is guaranteed by design but not tested.

DC CHARACTERISTICS

 V_{CC} = 5.0V, V_{SS} = 0V, -55°C ≤ T_A ≤ +125°C

Parameter	Sym	Conditions	-15		-17		-20		-25		Units
			Min	Max	Min	Max	Min	Max	Min	Max	
Input Leakage Current	I _{LI}	V _{CC} = 5.5, V _{IN} = GND to V _{CC}		10		10		10		10	µA
Output Leakage Current	I _{LO}	CS# = V _{IH} , OE# = V _{IH} , V _{OUT} = GND to V _{CC}		10		10		10		10	µA
Operating Supply Current	I _{CC}	CS# = V _{IL} , OE# = V _{IH} , f = 5MHz, V _{CC} = 5.5		600		600		600		600	mA
Standby Current	I _{SB}	CS# = V _{IH} , OE# = V _{IH} , f = 5MHz, V _{CC} = 5.5		80		80		80		60	mA
Output Low Voltage	V _{OL}	I _{OL} = 8mA, V _{CC} = 4.5		0.4		0.4		0.4		0.4	V
Output High Voltage	V _{OH}	I _{OH} = -4.0mA, V _{CC} = 4.5	2.4		2.4		2.4		2.4		V

Parameter	Sym	Conditions	-35		-45		-55		Units
			Min	Max	Min	Max	Min	Max	
Input Leakage Current	I _{LI}	V _{CC} = 5.5, V _{IN} = GND to V _{CC}		10		10		10	µA
Output Leakage Current	I _{LO}	CS# = V _{IH} , OE# = V _{IH} , V _{OUT} = GND to V _{CC}		10		10		10	µA
Operating Supply Current	I _{CC}	CS# = V _{IL} , OE# = V _{IH} , f = 5MHz, V _{CC} = 5.5		600		600		600	mA
Standby Current	I _{SB}	CS# = V _{IH} , OE# = V _{IH} , f = 5MHz, V _{CC} = 5.5		60		60		60	mA
Output Low Voltage	V _{OL}	I _{OL} = 8mA, V _{CC} = 4.5		0.4		0.4		0.4	V
Output High Voltage	V _{OH}	I _{OH} = -4.0mA, V _{CC} = 4.5	2.4		2.4		2.4		V

 NOTE: DC test conditions: V_{IH} = V_{CC} - 0.3V, V_{IL} = 0.3V

DATA RETENTION CHARACTERISTICS (For WS128K32L-XXX Only)

 -55°C ≤ T_A ≤ +125°C, -40°C ≤ T_A ≤ +85°C

Characteristic	Sym	Conditions	Min	Typ	Max	Units
Data Retention Voltage	V _{CC}	V _{CC} = 2.0V	2	-	-	V
Data Retention Quiescent Current	I _{CCDR}	CS ³ V _{CC} - 0.2V	-	1	2	mA
Chip Disable to Data Retention Time (1)	T _{CDR}	V _{IN} ³ V _{CC} - 0.2V	0	-	-	ns
Operation Recovery Time (1)	T _R	or V _{IN} 0.2V	TRC	-	-	ns

NOTE: Parameter guaranteed, but not tested.

AC CHARACTERISTICS
 $V_{CC} = 5.0V, GND = 0V, -55^{\circ}C \leq T_A \leq +125^{\circ}C$

Parameter	Symbol	-15		-17		-20		-25		-35		-45		-55		Units
		Min	Max	Min	Max	Min	Max	Min	Max	Min	Max	Min	Max	Min	Max	
Read Cycle Time	t _{RC}	15		17		20		25		35		45		55		ns
Address Access Time	t _{AA}		15		17		20		25		35		45		55	ns
Output Hold from Address Change	t _{OH}	0		0		0		0		0		0		0		ns
Chip Select Access Time	t _{ACS}		15		17		20		25		35		45		55	ns
Output Enable to Output Valid	t _{OE}		10		10		12		15		20		25		30	ns
Chip Select to Output in Low Z	t _{CLZ} ¹	3		3		3		3		3		3		3		ns
Output Enable to Output in Low Z	t _{OLZ} ¹	0		0		0		0		0		0		0		ns
Chip Disable to Output in High Z	t _{CHZ} ¹		12		12		12		12		15		20		20	ns
Output Disable to Output in High Z	t _{OHZ} ¹		12		12		12		12		15		20		20	ns

1. This parameter is guaranteed by design but not tested.

AC CHARACTERISTICS
 $V_{CC} = 5.0V, GND = 0V, -55^{\circ}C \leq T_A \leq +125^{\circ}C$

Parameter	Symbol	-15		-17		-20		-25		-35		-45		-55		Units
		Min	Max	Min	Max	Min	Max	Min	Max	Min	Max	Min	Max	Min	Max	
Write Cycle Time	t _{WC}	15		17		20		25		35		45		55		ns
Chip Select to End of Write	t _{CW}	14		14		15		20		25		30		45		ns
Address Valid to End of Write	t _{AW}	14		15		15		20		25		30		45		ns
Data Valid to End of Write	t _{DW}	10		10		12		15		20		25		25		ns
Write Pulse Width	t _{WP}	14		14		15		20		25		30		45		ns
Address Setup Time	t _{AS}	0		0		0		0		0		0		0		ns
Address Hold Time	t _{AH}	0		0		0		0		0		0		0		ns
Output Active from End of Write	t _{OW} ¹	3		3		3		3		4		4		4		ns
Write Enable to Output in High Z	t _{WHZ} ¹		10		10		12		15		20		25		25	ns
Data Hold Time	t _{DH}	0		0		0		0		0		0		0		ns

1. This parameter is guaranteed by design but not tested.

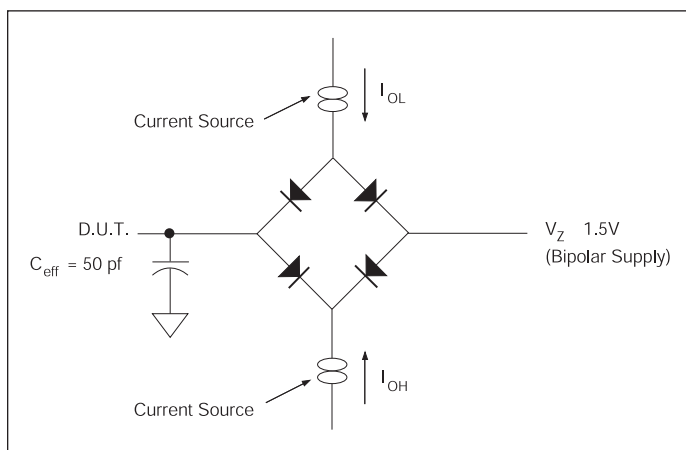
FIGURE. 4 – AC TEST CIRCUIT

AC Test Conditions

Parameter	Typ	Unit
Input Pulse Levels	$V_{IL} = 0, V_{IH} = 3.0$	V
Input Rise and Fall	5	ns
Input and Output Reference Level	1.5	V
Output Timing Reference Level	1.5	V

Notes:

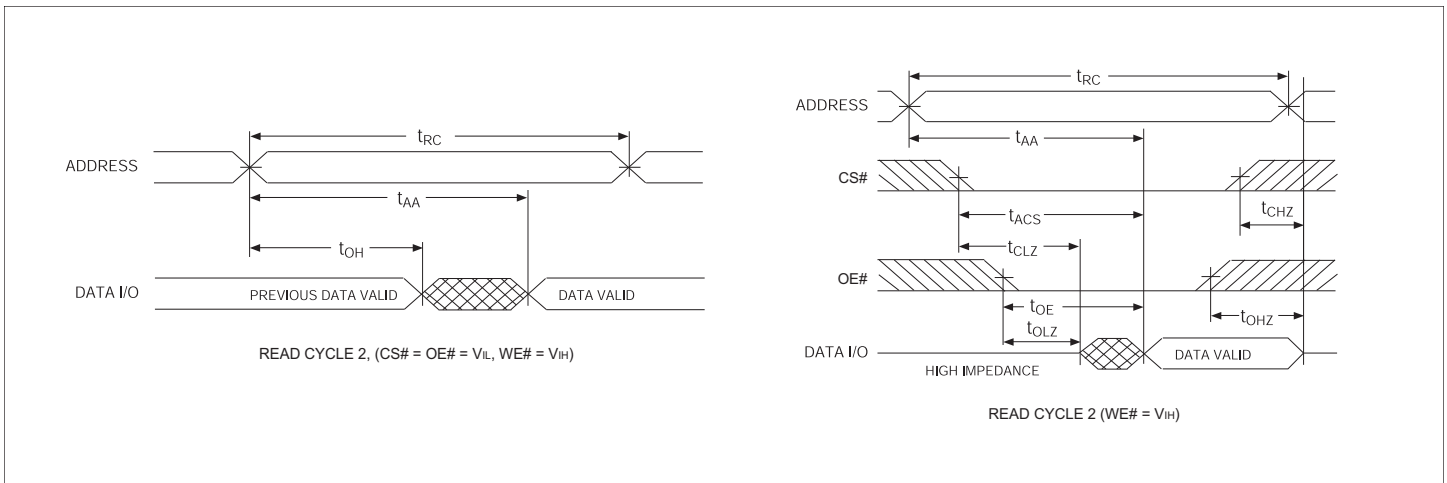
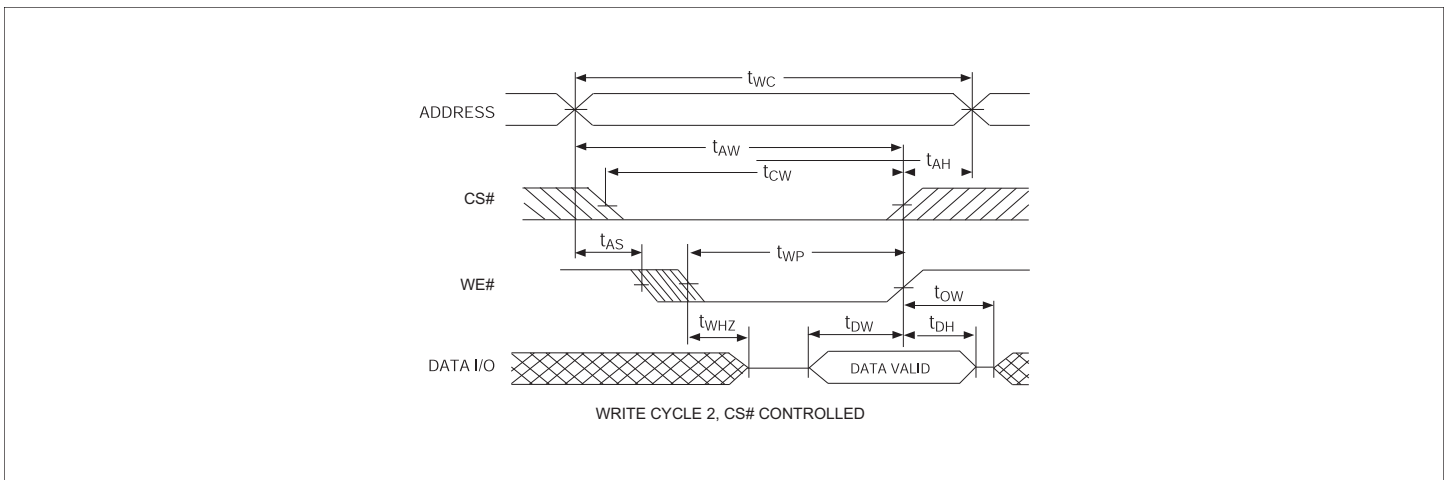
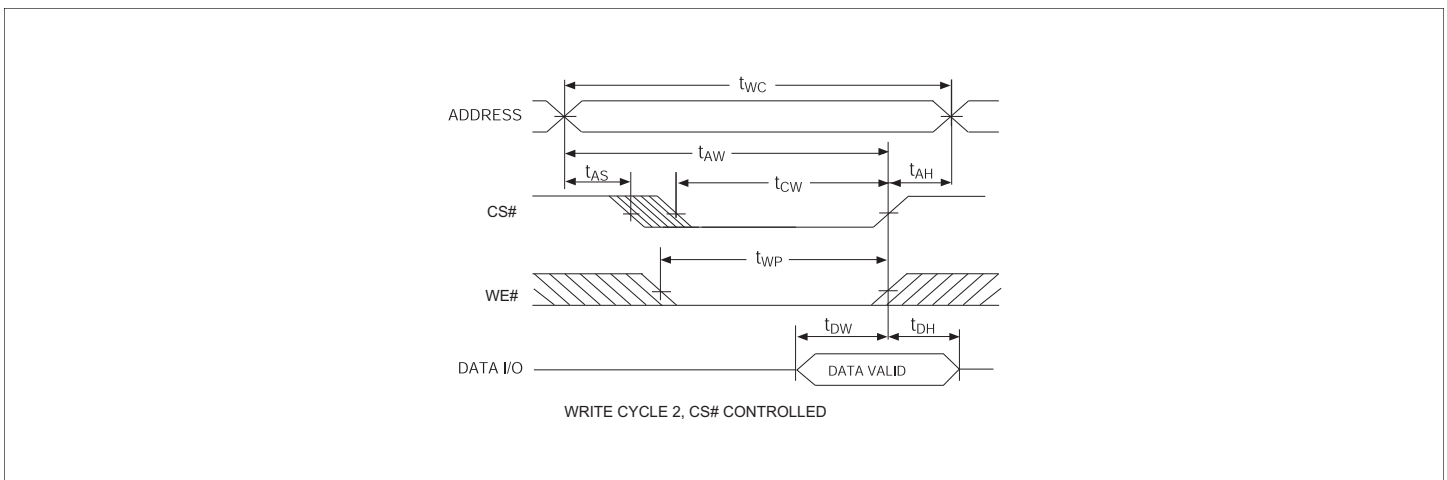
V_Z is programmable from -2V to +7V.
 I_{OL} & I_{OH} programmable from 0 to 16mA.
 Tester Impedance $Z_0 = 75 \Omega$.
 V_Z is typically the midpoint of V_{OH} and V_{OL} .
 I_{OL} & I_{OH} are adjusted to simulate a typical resistive load circuit.
 ATE tester includes jig capacitance.

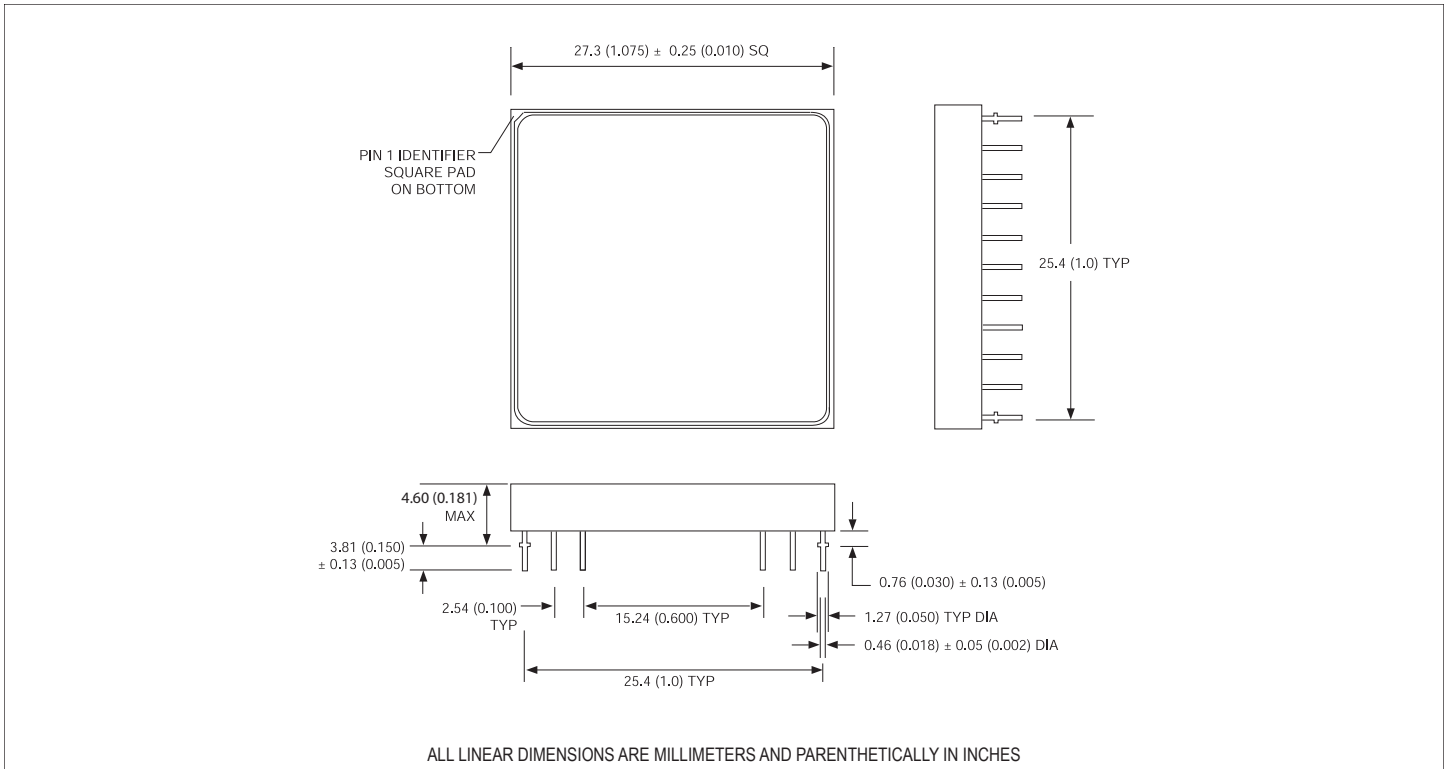
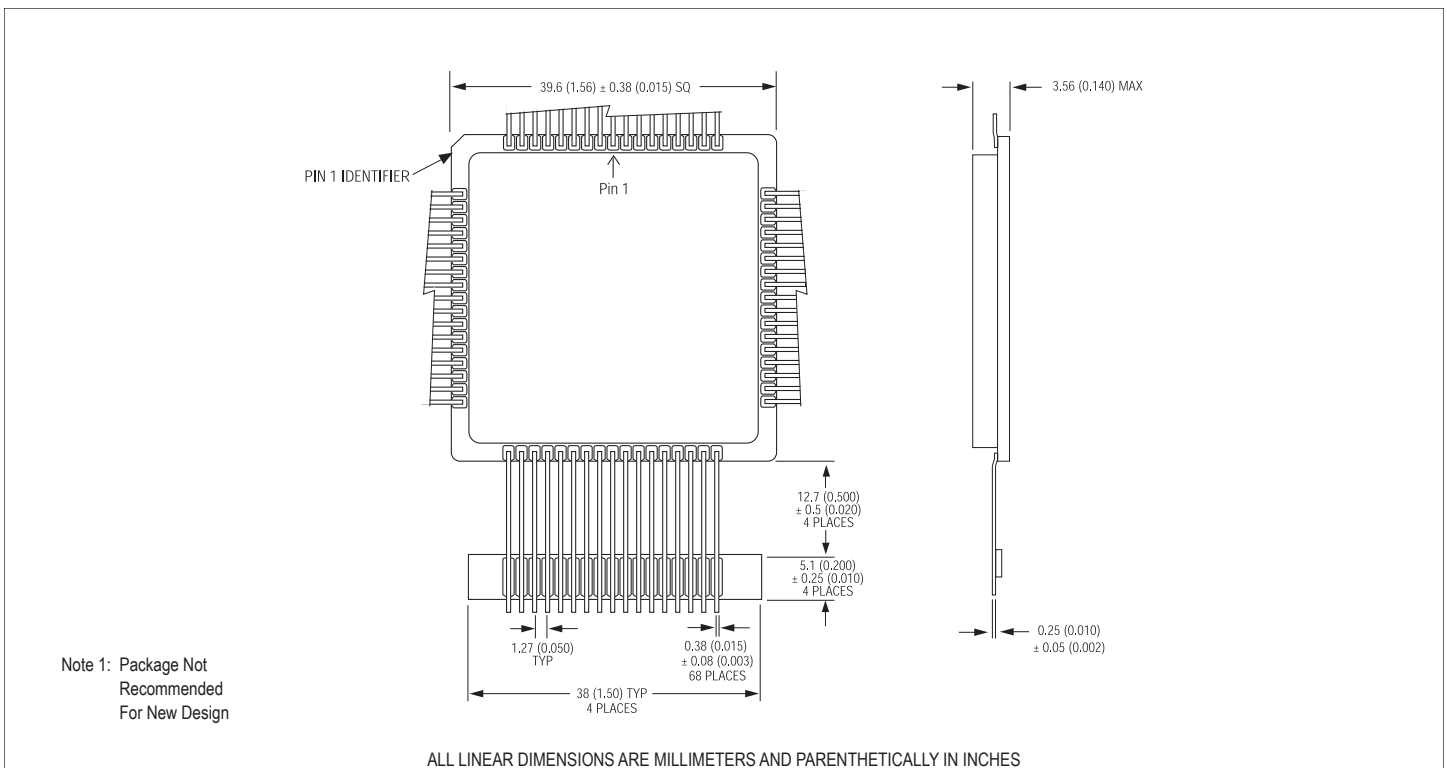
FIGURE 5 – TIMING WAVEFORM - READ CYCLE

FIGURE 6 – WRITE CYCLE - WE# CONTROLLED

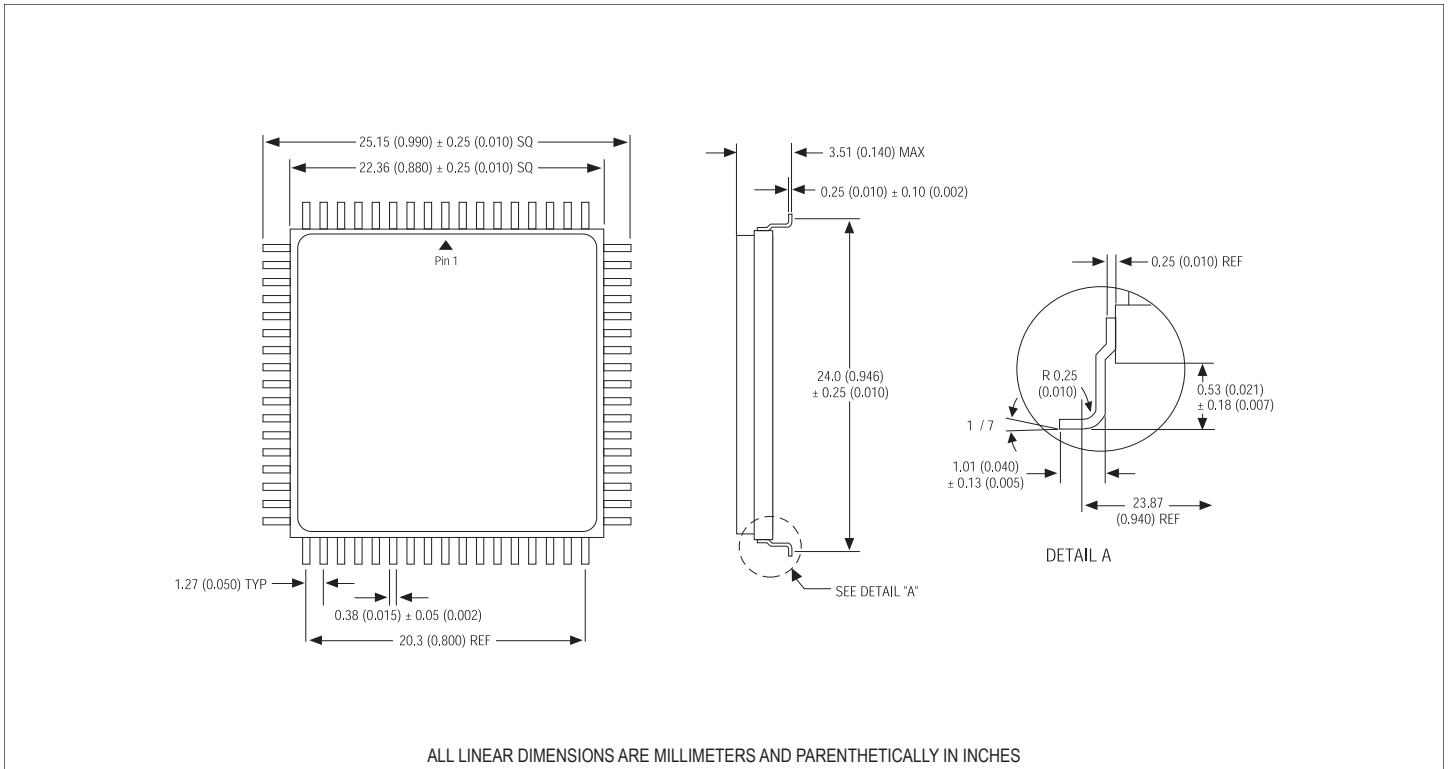
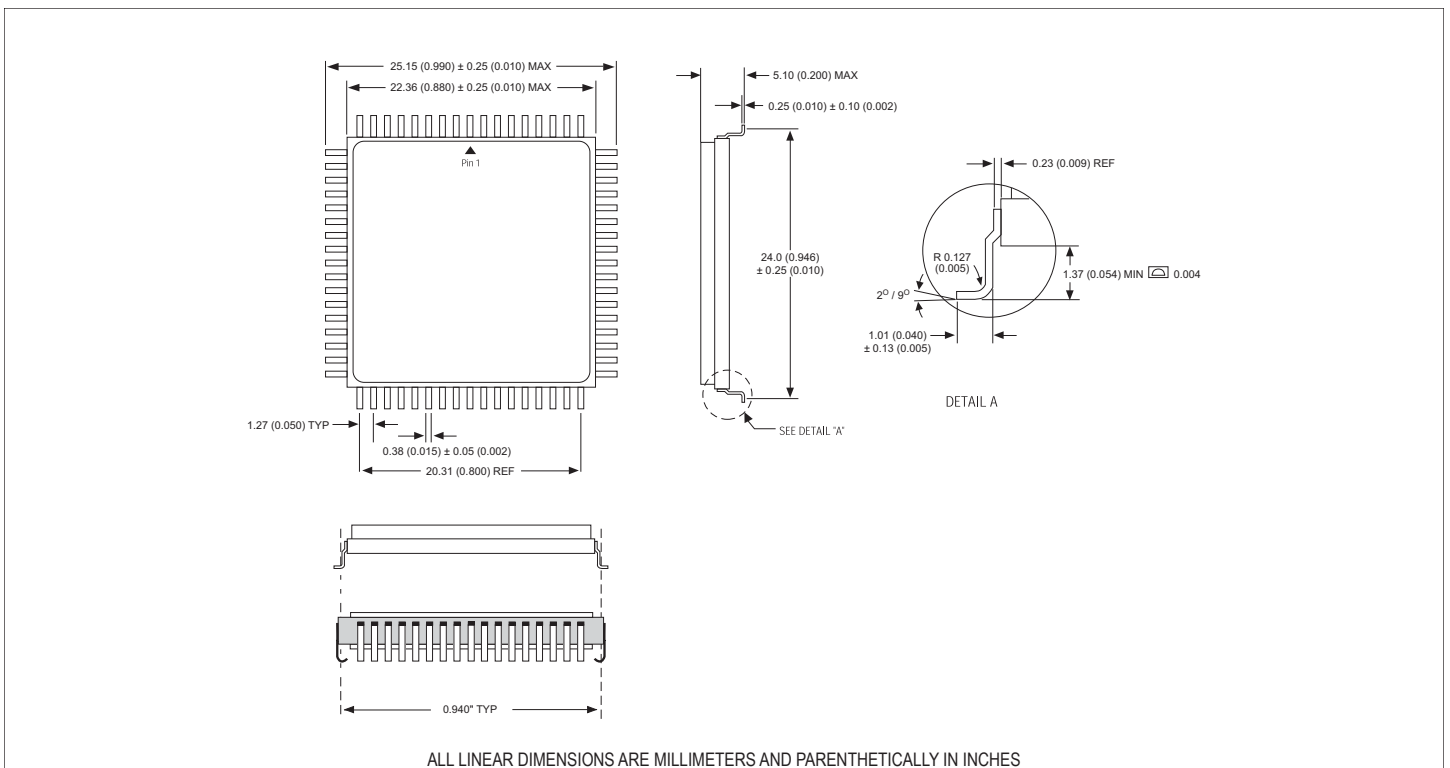
FIGURE 7 – WRITE CYCLE - CS# CONTROLLED

PACKAGE 400: 66 PIN, PGA TYPE, CERAMIC HEX-IN-LINE PACKAGE, HIP (H1)

PACKAGE 502: 68 LEAD, CERAMIC QUAD FLAT PACK, LOW PROFILE CQFP (G4T)¹

PACKAGE 510: 68 LEAD, CERAMIC QUAD FLAT PACK, CQFP (G2U)

PACKAGE 528: 68 LEAD, CERAMIC QUAD FLAT PACK, CQFP (G2L)



ORDERING INFORMATION

	W	S	128K32	X	-	XXX	X	X	X
White Electronic Designs Corporation (Microsemi corporation)									
SRAM									
ORGANIZATION, 128Kx32 User configurable as 256Kx16 or 512Kx8									
IMPROVEMENT MARK: N = No Connect at pin 8, 21, 28 and 39 in HIP for Upgrades L = Low Power*									
ACCESS TIME (ns)									
PACKAGE TYPE: H1 = 1.075" sq. Ceramic Hex-In-line Package, HIP (Package 400) G2U = 22.4mm Ceramic Quad Flat Pack, CQFP (Package 510) G2L = 22.4mm Ceramic Quad Flat Pack, CQFP (Package 528) G4T ¹ = 40 mm Low Profile CQFP (Package 502)									
DEVICE GRADE: Q = MIL-STD-883 Compliant M = Military Screened -55°C to +125°C I = Industrial -40°C to +85°C C = Commercial 0°C to +70°C									
LEAD FINISH: Blank = Gold plated leads A = Solder dip leads									

Note 1: Package Not Recommended For New Designs
* Low Power Data Retention only available in G2U, G2L, PackageTypes

DEVICE TYPE	SPEED	PACKAGE	SMD NO.
128K x 32 SRAM Module	55ns	66 pin HIP (H1)	5962-93187 05H4X
128K x 32 SRAM Module	45ns	66 pin HIP (H1)	5962-93187 06H4X
128K x 32 SRAM Module	35ns	66 pin HIP (H1)	5962-93187 07H4X
128K x 32 SRAM Module	25ns	66 pin HIP (H1)	5962-93187 08H4X
128K x 32 SRAM Module	20ns	66 pin HIP (H1)	5962-93187 09H4X
128K x 32 SRAM Module	17ns	66 pin HIP (H1)	5962-93187 10H4X
128K x 32 SRAM Module	15ns	66 pin HIP (H1)	5962-93187 11H4X
128K x 32 SRAM Module	55ns	68 lead CQFP Low Profile (G4T) ¹	5962-95595 05HYX ¹
128K x 32 SRAM Module	45ns	68 lead CQFP Low Profile (G4T) ¹	5962-95595 06HYX ¹
128K x 32 SRAM Module	35ns	68 lead CQFP Low Profile (G4T) ¹	5962-95595 07HYX ¹
128K x 32 SRAM Module	25ns	68 lead CQFP Low Profile (G4T) ¹	5962-95595 08HYX ¹
128K x 32 SRAM Module	20ns	68 lead CQFP Low Profile (G4T) ¹	5962-95595 09HYX ¹
128K x 32 SRAM Module	17ns	68 lead CQFP Low Profile (G4T) ¹	5962-95595 10HYX ¹
128K x 32 SRAM Module	15ns	68 lead CQFP Low Profile (G4T) ¹	5962-95595 11HYX ¹
128K x 32 SRAM Module	55ns	68 lead CQFP/J (G2U)	5962-95595 05HMX
128K x 32 SRAM Module	45ns	68 lead CQFP/J (G2U)	5962-95595 06HMX
128K x 32 SRAM Module	35ns	68 lead CQFP/J (G2U)	5962-95595 07HMX
128K x 32 SRAM Module	25ns	68 lead CQFP/J (G2U)	5962-95595 08HMX
128K x 32 SRAM Module	20ns	68 lead CQFP/J (G2U)	5962-95595 09HMX
128K x 32 SRAM Module	17ns	68 lead CQFP/J (G2U)	5962-95595 10HMX
128K x 32 SRAM Module	15ns	68 lead CQFP/J (G2U)	5962-95595 11HMX
128K x 32 SRAM Module	55ns	68 lead CQFP/J (G2L)	5962-95595 05HAX
128K x 32 SRAM Module	45ns	68 lead CQFP/J(G2L)	5962-95595 06HAX
128K x 32 SRAM Module	35ns	68 lead CQFP/J(G2L)	5962-95595 07HAX
128K x 32 SRAM Module	25ns	68 lead CQFP/J(G2L)	5962-95595 08HAX
128K x 32 SRAM Module	20ns	68 lead CQFP/J(G2L)	5962-95595 09HAX
128K x 32 SRAM Module	17ns	68 lead CQFP/J(G2L)	5962-95595 10HAX
128K x 32 SRAM Module	15ns	68 lead CQFP/J(G2L)	5962-95595 11HAX

Note 1: Package Not Recommended For New Design