



Worldsemi

WORLDSEMI CO., LIMITED

WS2812D-F5-15mA

Intelligent control LED integrated light source

Apr-2017

Features and Benefits

- The control circuit and the LED share the only power source.
- Control circuit and RGB chip are integrated in a package of 5mm round diameter LED components, form a complete control of pixel point.
- Built-in signal reshaping circuit, after wave reshaping to the next driver, ensure wave-form distortion not accumulate.
- Built-in electric reset circuit and power lost reset circuit.
- Each pixel of the three primary color can achieve 256 brightness display, completed 16777216 color full color display, and scan frequency not less than 2KHz.
- Cascading port transmission signal by single line.
- Any two point the distance not more than 3m transmission signal without any increase circuit.
- When the refresh rate is 30fps, cascade number are not less than 1024 points.
- Send data at speeds of 800Kbps.
- The color of the light is highly consistent, cost-effective.

Applications

- Full-color module, Full color soft lights a lamp strip.
- LED decorative lighting, Indoor/outdoor LED video irregular screen.

General description

WS2812D-F5 is a intelligent control LED light source that the control circuit and RGB chip are integrated in a package of 5mm diameter LED components. Its internal include intelligent digital port data latch and signal reshaping amplification drive circuit. Also include a precision internal oscillator and a 12V voltage programmable constant current control part, effectively ensuring the pixel point light color height consistent.

The data transfer protocol use single NZR communication mode. After the pixel power-on reset, the DIN port receive data from controller, the first pixel collect initial 24bit data then sent to the internal data latch, the other data which reshaping by the internal signal reshaping amplification circuit sent to the next cascade pixel through the DO port. After transmission for each pixel, the signal to reduce 24bit. pixel adopt auto reshaping transmit technology, making the pixel cascade number is not limited the signal transmission, but only depends on the speed of signal transmission.

LED with low driving voltage, environmental protection and energy saving, high brightness, scattering angle is large, good consistency, low power, long life and other advantages. The control chip integrated in LED above becoming more simple circuit, small volume, convenient installation.

Mechanical Dimensions & PIN Configuration

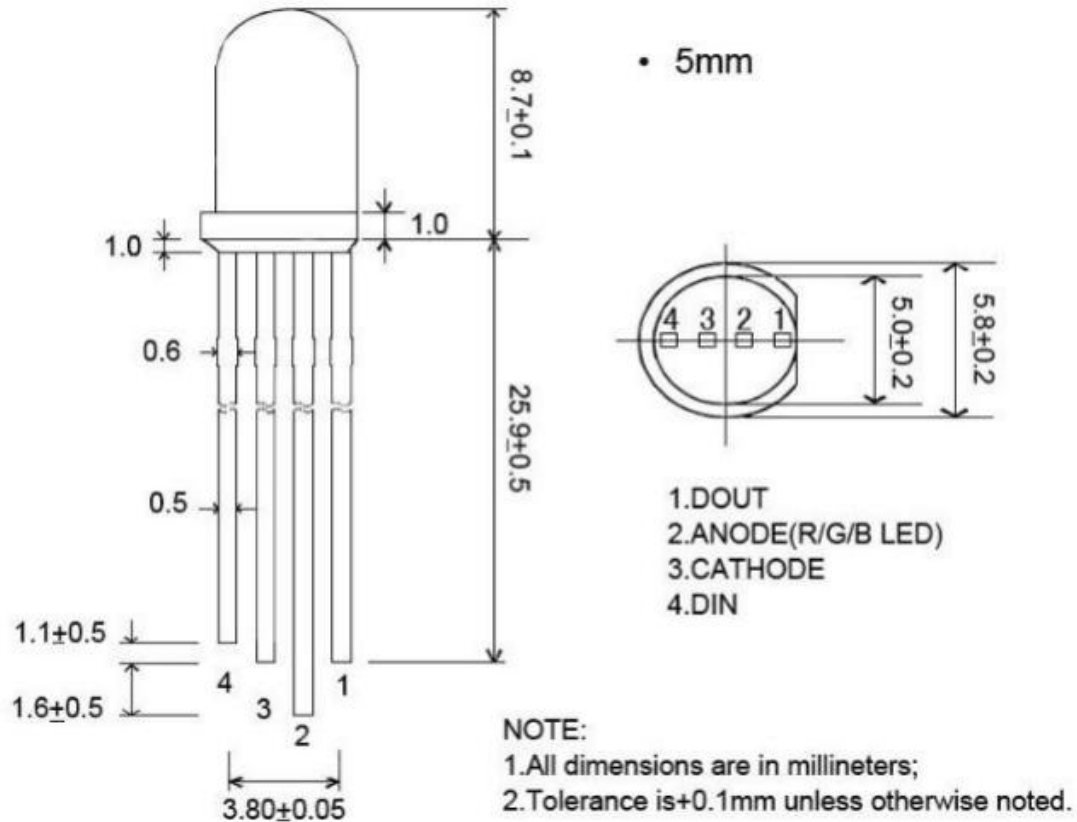

PIN Function

| NO. | Symbol | Function description |
|-----|--------|----------------------------|
| 1 | Dout | Control data signal output |
| 2 | VDD | Power supply LED |
| 3 | GND | Ground |
| 4 | Din | Control data signal input |

Absolute Maximum Ratings

| Parameter | Symbol | Ratings | Unit |
|--------------------------------|------------------|---------------------------|------|
| Power supply voltage | V _{DD} | +3.5~+5.3 | V |
| Input voltage | V _I | -0.5~V _{DD} +0.5 | V |
| Operation junction temperature | T _{opt} | -25~+80 | °C |
| Storage temperature range | T _{stg} | -40~+105 | °C |

Electrical Characteristics ($T_A=-20\sim+70^{\circ}\text{C}$, $V_{DD}=4.5\sim 5.5\text{V}$, $V_{SS}=0\text{V}$, unless otherwise specified)

| Parameter | Symbol | Conditions | Min | Tpy | Max | Unit |
|---------------------|----------|----------------------|-------------|------|--------------|---------------|
| Input current | I_I | $V_I=V_{DD}/V_{SS}$ | — | — | ± 1 | μA |
| Input voltage level | V_{IH} | D_{IN}, SET | $0.7V_{DD}$ | — | — | V |
| | V_{IL} | D_{IN}, SET | — | — | $0.3 V_{DD}$ | V |
| Hysteresis voltage | V_H | D_{IN}, SET | — | 0.35 | — | V |

Switching Characteristics ($T_A=-20\sim+70^{\circ}\text{C}$, $V_{DD}=4.5\sim 5.5\text{V}$, $V_{SS}=0\text{V}$, unless otherwise specified)

| Parameter | Symbol | Condition | Min | Tpy | Max | Unit |
|-------------------------|-----------|---|-----|-----|-----|---------------|
| Transmission delay time | t_{PLZ} | $CL=15\text{pF}$, $D_{IN}\rightarrow D_{OUT}$, $RL=10\text{K}\Omega$ | — | — | 300 | ns |
| Fall time | t_{THZ} | $CL=300\text{pF}$, $OUTR/OUTG/OUTB$ | — | — | 120 | μs |
| Input capacity | C_I | — | — | — | 15 | pF |

LED Characteristics

| Color | Wavelength(nm) | Operating Current(mA) | Operating Voltage(V) |
|--------------|----------------|-----------------------|----------------------|
| RED | 620-630 | 16 | 1.8-2.2 |
| GREEN | 515-530 | 16 | 2.8-3.1 |
| BLUE | 465-475 | 16 | 2.9-3.2 |

Data Transfer Time ($T_H+T_L=1.25\mu\text{s}\pm 600\text{ns}$)

| | | |
|-----|---------------------------|-------------------------|
| T0H | 0 code, high voltage time | 220ns~380ns |
| T1H | 1 code, high voltage time | 750ns~1.6 μs |
| T0L | 0 code, low voltage time | 750ns~1.6 μs |
| T1L | 1 code, low voltage time | 220ns~420ns |
| RES | low voltage time | >300 μs |

Sequence chart:

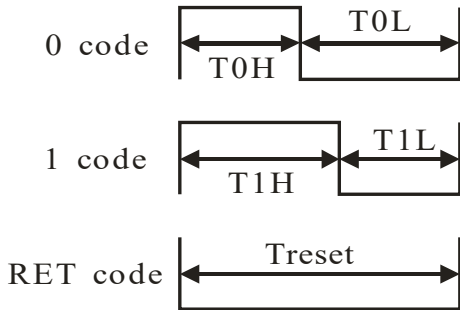

Cascade method:

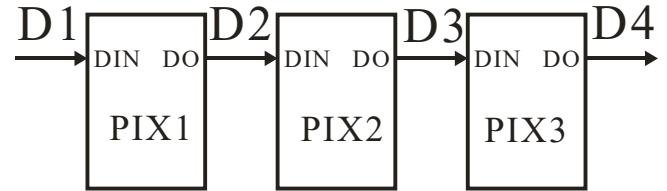

Data transmission method:

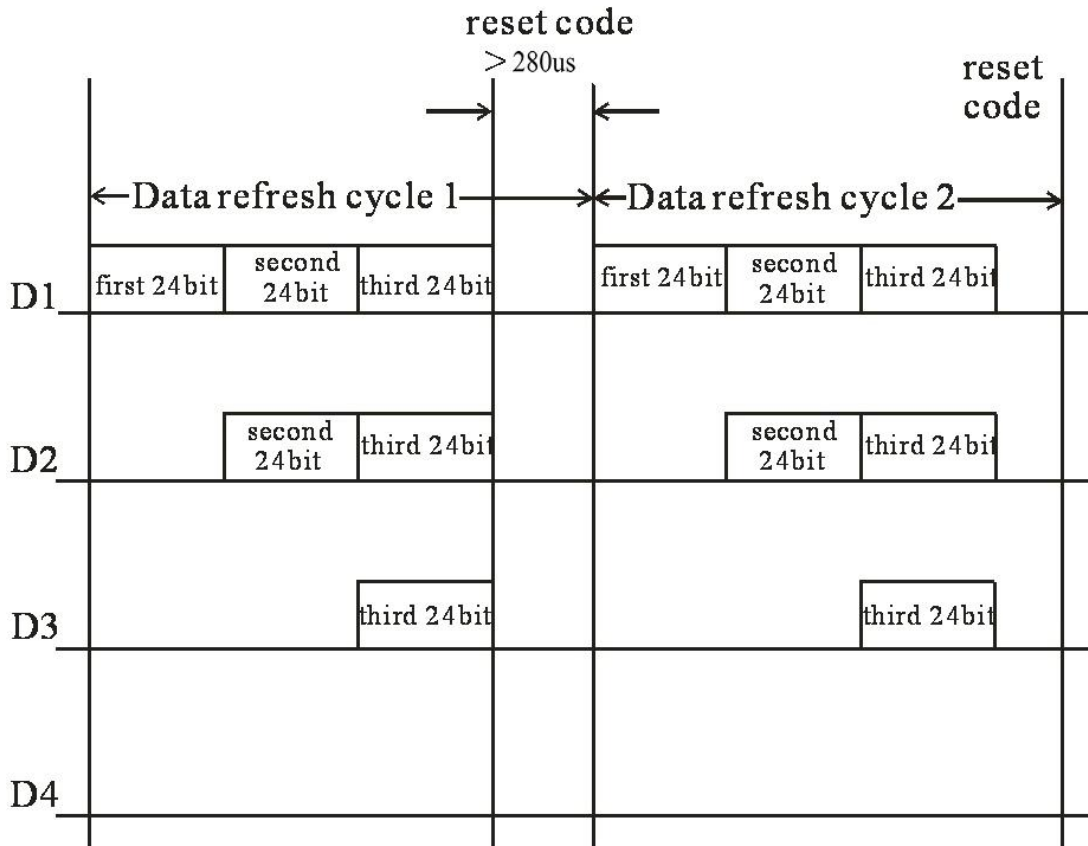

Note: The data of D1 is send by MCU, and D2, D3, D4 through pixel internal reshaping amplification to transmit.

Composition of 24bit data

| | | | | | | | | | | | | | | | | | | | | | | | |
|----|----|----|----|----|----|----|----|----|----|----|----|----|----|----|----|----|----|----|----|----|----|----|----|
| G7 | G6 | G5 | G4 | G3 | G2 | G1 | G0 | R7 | R6 | R5 | R4 | R3 | R2 | R1 | R0 | B7 | B6 | B5 | B4 | B3 | B2 | B1 | B0 |
|----|----|----|----|----|----|----|----|----|----|----|----|----|----|----|----|----|----|----|----|----|----|----|----|

Note: Data transmit in order of GRB, high bit data at first.

Typical application circuit

