

WS3220A High Precision PSR Constant Current LED Driver

Features

- Built-in 650V Power MOSFET
- $\pm 5\%$ LED Current Accuracy
- Primary-side Sensing and Regulation Without TL431 and Opto-coupler
- No Auxiliary Winding For Sensing And Supplying
- Ultra low operating current
- LED Open/Short Circuit Protection
- CS Resistor Short Circuit Protection
- VCC Clamp & under voltage lockout(UVLO)
- Over Temperature Protection

Applications

- GU10 LED driver
- LED spot light
- Other LED lighting

General Description

WS3220A is a high precision primary-side feedback

and regulation controller for LED lighting, it operates in constant current control mode and is designed to work in inductor current discontinuous conduction mode and especially suitable for flyback convertor under universal input. The output power of system is recommended to less than 5W.

WS3220A integrates 650V power MOSFET. Since adopting primary sense and feedback control technology, the secondary sense and feedback circuit is eliminated. And it does not need the auxiliary winding for sensing the output current and supplying the chip. The low component counts and small system size are realized.

Since using the high accurate current sense method, WS3220A realizes $\pm 5\%$ accuracy of LED current along with excellent line and load regulation.

WS3220A offers comprehensive protection including Cycle-by-Cycle current limiting (OCP), LED open/short circuit protection, CS resistor short circuit protection, VCC UVLO and Clamp, and over temperature protection.

WS3220A is available in SOP8 package.

Typical Application Circuit

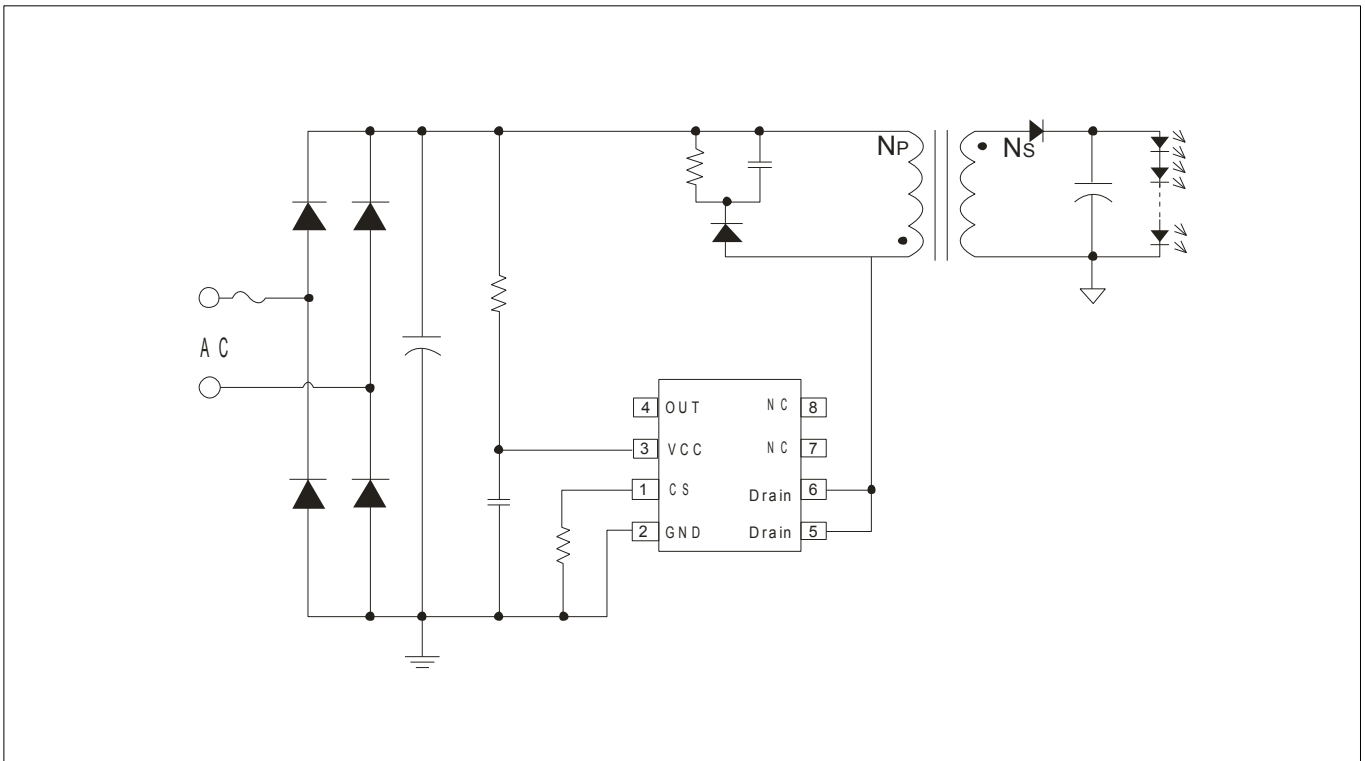

Pin Definition and Device Marking

WS3220A is offered in SOP-8 packages, as shown below:

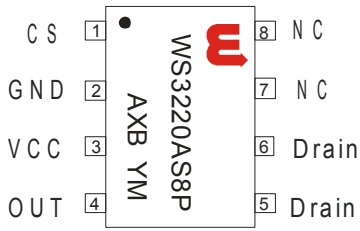

WS3220AS8P: Product code
A: Die Code
X: Internal Code
B: Area Code
YM: Year, Month

Pin Function Description

Pin Name	Pin Number	Pin Type	Function Description
CS	1	Current Sense	Current sense. This pin connects a current sense resistor to GND to detect the primary current of transformer.
GND	2	Ground	Ground.
VCC	3	Power Supply	Power supply.
OUT	4	Source	Internal high voltage MOSFET source.
Drain	5,6	Drain	Internal high voltage MOSFET drain.
NC	7,8	NC	No connection, must be floated

Block Diagram

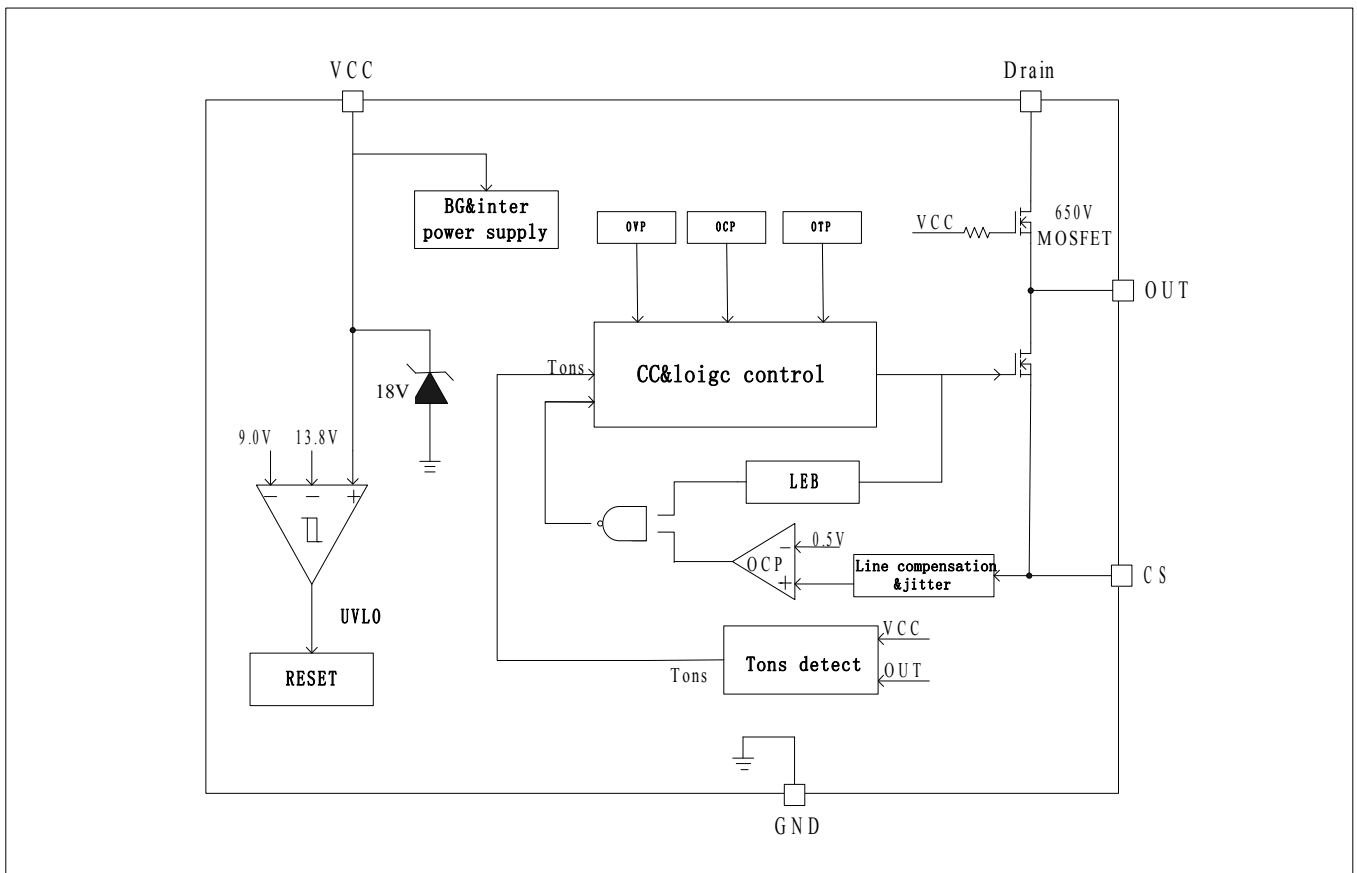

Ordering Information

Package	IC Marking Information	Purchasing Device Name
SOP8, Pb-free	WS3220AS8P	WS3220AS8P

Recommended Operating Condition

Symbol	Parameter	Value	Unit
VCC	VCC supply voltage	9~15	V
T _A	Operating temperature	-20~85	°C

Absolute Maximum Ratings

Symbol	Parameter	Value	Unit
I _{CC_max}	VCC pin maximum sink current	5	mA
Drain	Internal HV MOSFET drain voltage	-0.3~650	V
CS	CS pin input voltage	-0.3~7	V
OUT	OUT pin input voltage	-0.3~18	V
T _J	Operating junction temperature	-40~150	°C
T _{STG}	Min./Max. Storage temperature	-55~150	°C

Note: Stresses above those listed under Absolute Maximum Ratings may cause permanent damage to the device. These are stress ratings only, functional operation of the device at these or any other conditions beyond those indicated in the Recommended Operating Conditions section are not implied. Exposure to absolute maximum-rated conditions for extended periods may affect device reliability.

Electrical Characteristics ($T_A=25^{\circ}\text{C}$, $V_{CC}=14\text{V}$, if not otherwise noted)

symbol	parameter	Test condition	Min	Typ	Max	Unit
Supply Voltage (VCC)						
I_VCC_ST	Start up current	VCC=UVLO_ON-1V	-	60	100	uA
I_OP	Operation Current	Fop=50Khz	-	150	250	uA
UVLO_ON	Turn on threshold Voltage	VCC rising	12.5	13.8	15.5	V
UVLO_OFF	Turn-off threshold Voltage	VCC falling	8	9	10	V
VCC_Clamp	VCC Clamp voltage	Icc=1mA	-	18.2	-	V
Current Sense Section						
TLEB	Leading edge Blanking Time		-	500	-	ns
V _{TH_OC}	OCP threshold		485	500	515	mV
Tdelay	Switch off delay time		-	100	-	ns
Frequency Section						
Fmin	Minimum operation frequency		-	5	-	Khz
Fmax	Maximum operation frequency		-	90	-	Khz
Maximum Duty Cycle						
Dmax	Maximum duty cycle		-	42	-	%
MOSFET Section						
Rds_on	Static drain-source on-resistance	Vgs=10V/Ids=0.4A	-	-	17	Ω
BVdss	Drain-source breakdown voltage	Vgs=0V/Ids=250uA	650	-	-	V
Idss	Drain-source leakage current	Vgs=0V/Vds=650V	-	-	10	uA
Over Temperature Protection						
Tsd	Thermal shutdown threshold		-	150	-	$^{\circ}\text{C}$
Tsd_hys	Thermal shutdown hysteresis		-	25	-	$^{\circ}\text{C}$

Typical Operating Characteristics

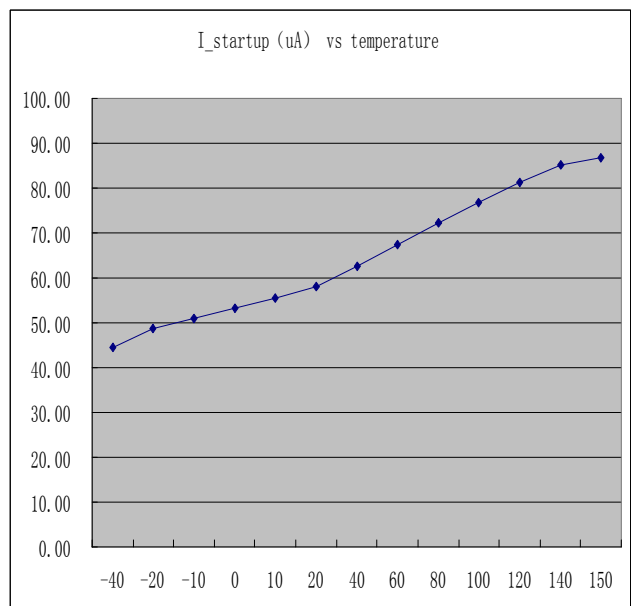
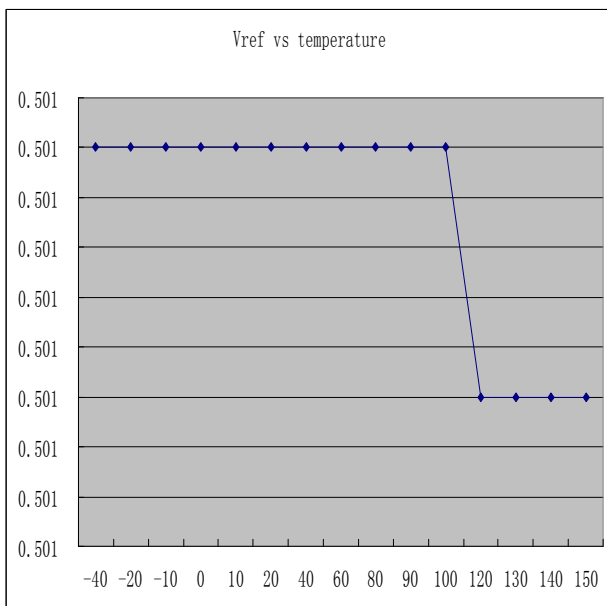
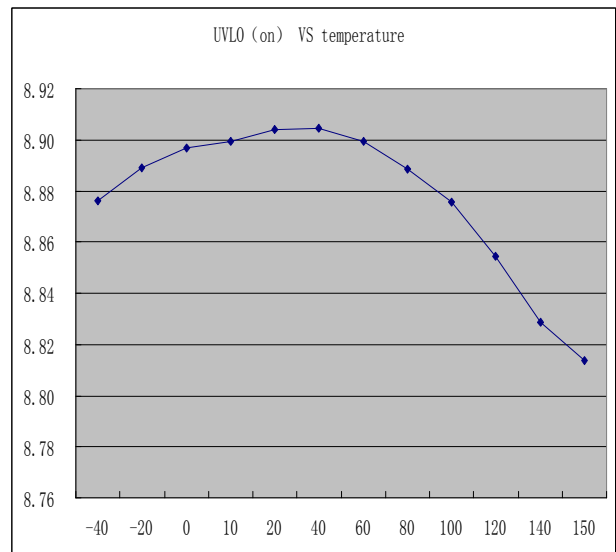
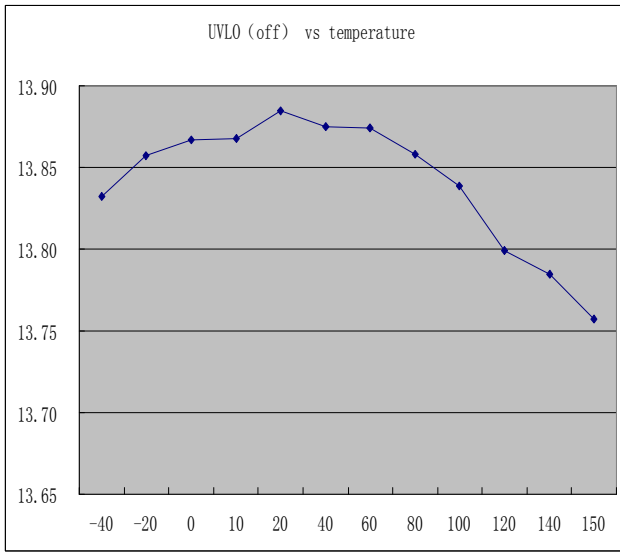

Function Description

WS3220A is a high performance power witch specially designed for LED lighting, with constant current control technology. WS3220A integrates a 650V power MOSFET. The accurate LED current can be realized without opto-coupler, TL431 feedback circuit and auxiliary winding while minimizing the external component count, lowering the total bill of material cost.

Startup Current

he start-up current in WS3220A is designed to as low as 60uA. The VCC capacitor will be charged through the start-up resistor when the system is powered on. Once the VCC voltage reaches the start-up threshold, the WS3220A will start to switch. WS3220A integrates a 18V zener for VCC clamping. Due to the ultra-low operating current, the auxiliary winding is not needed to supply the IC.

CC Operation

Cycle-by-Cycle current sense is adopted in WS3220A CS is connected to the current sense comparator, and the voltage on CS will be compared with the internal 500mV reference voltage, the MOSFET will be switched off when the voltage on CS reaches the threshold. The output of the comparator includes a 500ns leading edge blanking time. The primary peak current is given by:

$$I_{pk}=0.5/Rcs \text{ (A)}$$

The current in LED can be calculated by the equation:

$$\begin{aligned} I_o &= 0.5 * I_{pk} * N_p / N_s * T_{ons} / T \\ &= 0.25 * I_{pk} * N_p / N_s \\ &= 0.125 / Rcs * N_p / N_s \end{aligned}$$

Where,

NP: primary winding turns of transformer

NS: secondary winding turns of transformer

Rcs: The value of the sense resistance

I_{pk}: peak current in MOSFET

And the output current can be set by adjusting the current sense resistor Rcs.

Power MOSFET

The WS3220A integrates a 650V power N-MOSFET. It Can minimize the external component count and reduce the

BOM cost and PCB size. The WS3220A uses SOP-8 package. The recommended system output power is below 5W in universal input application.

Operation switching frequency

The WS3220A is designed to work in discontinuous conduction mode and no external loop compensation component is required while maintaining stability, The maximum duty cycle is limited to 42%. The maximum switching frequency at normal operation is suggested to set around 50KHz~55KHz. If the maximum frequency is set too high, it will affect the number of maximum series LED lamps. If set too low, the LED open circuit voltage will be too high. The maximum and minimum switching frequency is limited in WS3220A to ensure the stability of system. The switching frequency can be set by the formula:

$$f=Np^2*Vled/ (8*Ns^2*LP*Io)$$

Where, LP is the primary winding inductance of transformer.

Current Limiting and Leading Edge Blanking

Cycle-by-Cycle current limiting is offered in WS3220A. The switch current is detected by a sense resistor into the sense pin. An internal leading edge blanking circuit chops off the sense voltage spike at initial MOSFET on state due to snubber diode reverse recovery so that the external RC filtering on sense input is no longer required. The current limit comparator is disabled and thus cannot turn off the internal MOSFET during the blanking period.

Protection Controls

Excellent system stability is achieved by the comprehensive protection of WS3220A. Including Cycle-by-Cycle current limiting (OCP), LED open/short circuit protection, CS resistor short circuit protection, VCC UVLO and Clamp, over temperature protection, and so on.

When the LED is open circuit, it will trigger over-voltage protection logic and latch, the system stops switching immediately; When the LED short circuit is detected, the system works at low frequency(Fop=5Khz), so the power loss is low. At some catastrophic fault condition, such as shorted CS resistor or flyback transformer saturation, the internal fast fault detection circuit will trigger and latch, the

system stops switching immediately.

After the system enters into fault latch condition, the VCC voltage will fall until it reaches UVLO threshold. Then the system will re-start again. If the fault condition is removed, the system will recover to normal operation.

The thermal shutdown circuitry in the WS3220A senses the

die temperature after start up, and the thermal protection threshold is set to 150°C with a 25°C hysteresis. When the temperature on die of WS3220A rises and reaches the threshold, the power MOSFET will be shut down immediately and maintained switch off until the temperature on die falls 25°C from thermal protection trigger point.

SOP-8 Package Information

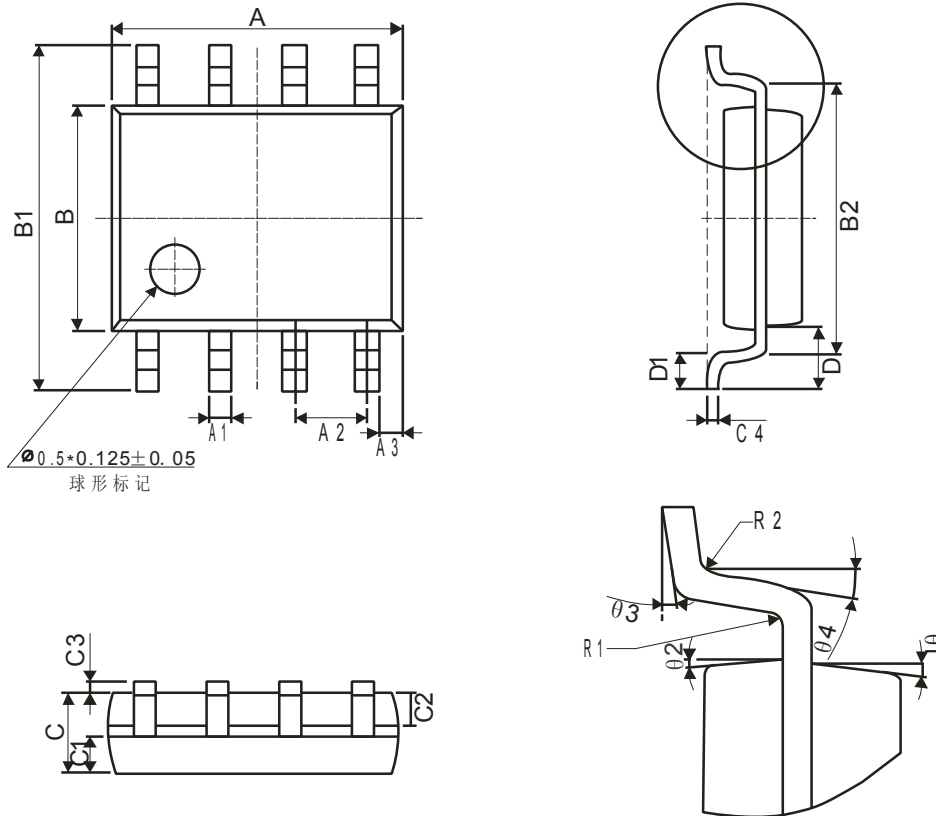

Winsemi				
Symbol	Dimensions in Millimeters		Dimensions in Inches	
	Min	Max	Min	Max
A	4.70	5.10	0.185	0.201
B	3.70	4.10	0.146	0.161
C	1.30	1.50	0.051	0.059
A1	0.35	0.48	0.014	0.019
A2	1.27TYP		0.05TYP	
A3	0.345TYP		0.014TYP	
B1	5.80	6.20	0.228	0.244
B2	5.00TYP		0.197TYP	
C1	0.55	0.70	0.022	0.028
C2	0.55	0.70	0.022	0.028
C3	0.05	0.225	0.002	0.009
C4	0.203TYP		0.008TYP	
D	1.05TYP		0.041TYP	
D1	0.40	0.80	0.016	0.031

NOTE:

- 1.We strongly recommend customers check carefully on the trademark when buying our product, if there is any question, please don't be hesitate to contact us.
- 2.Please do not exceed the absolute maximum ratings of the device when circuit designing.
- 3.Winsemi Microelectronics Co., Ltd reserved the right to make changes in this specification sheet and is subject to change without prior notice.

CONTACT:

Winsemi Microelectronics Co., Ltd.

ADD:Room 1002, East, Phase 2, HighTech Plaza,Tian-An Cyber Park,Chegongmiao, FuTian, Shenzhen, P.R.
China

Post Code : 518040

Tel : +86-755-8250 6288

FAX : +86-755-8250 6299

Web Site : www.winsemi.com