

WS3231 High PF PSR Constant Current LED Driver

Features

- $\pm 5\%$ LED Current Accuracy
- Primary-side Sensing and Regulation Without TL431 and Opto-coupler
- No Auxiliary Winding For Sensing And Supplying
- High Power Factor Correction
- QR mode
- 600V MOS integrated
- Ultra low operating current
- LED Open/Short Circuit Protection
- CS Resistor Short Circuit Protection
- VCC over voltage protection & under voltage lockout(UVLO)
- Over Temperature Protection

Applications

- GU10 LED driver
- LED spot light
- Other LED lighting

General Description

WS3231 is a high PF primary-side feedback and regulation controller for LED lighting, optimized for flyback converter with the output power less than 30W.

Since adopting primary sense and feedback control technology, the secondary sense and feedback circuit is eliminated. And WS3231 does not need the auxiliary winding for sensing the output current and supplying the chip. The low component counts and small system size are realized.

Since using the high accurate current sense method, WS3231 realizes $\pm 5\%$ accuracy of LED current along with excellent line and load regulation.

WS3231 offers comprehensive protection including Cycle-by-Cycle current limiting (OCP), LED open/short circuit protection, CS resistor short circuit protection, VCC UVLO,OVP and Clamp, and over temperature protection.

WS3231 is available in SOP-8 package.

Typical Application Circuit

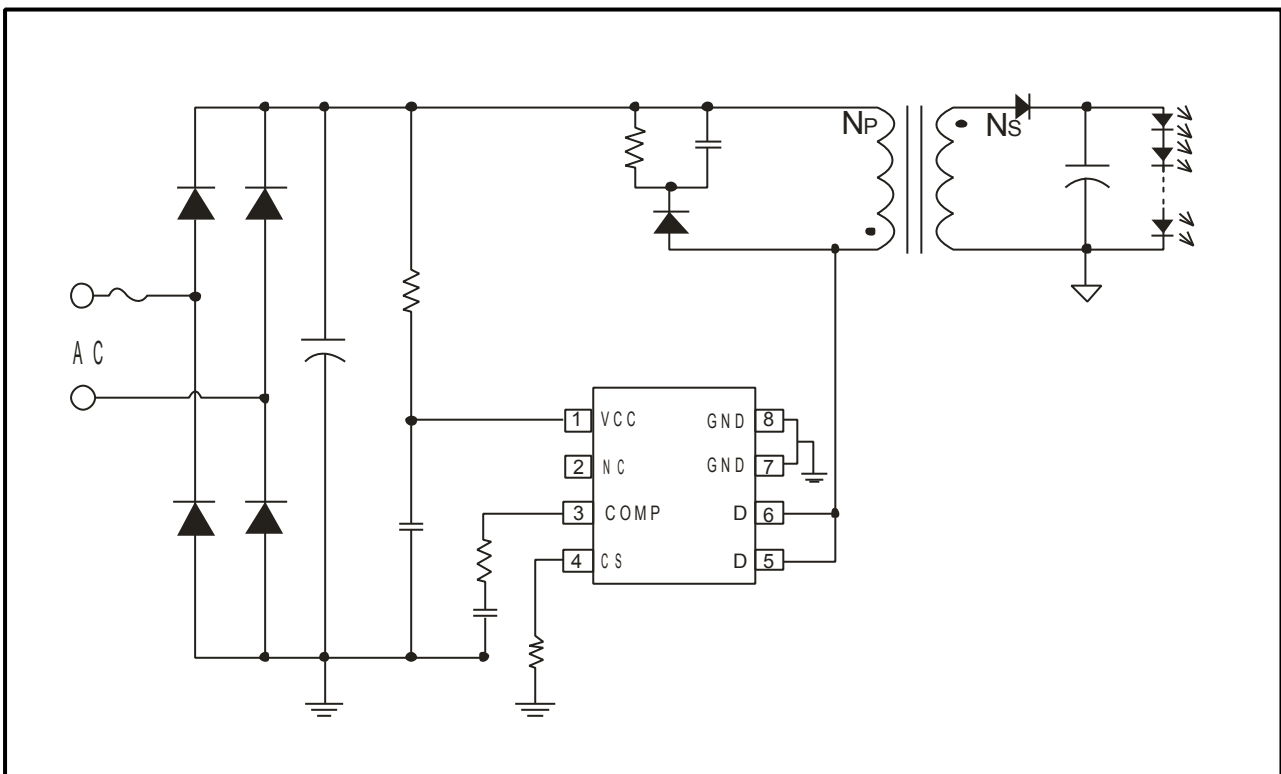

Pin Definition and Device Marking

WS3231 is available in SOP-8 package:

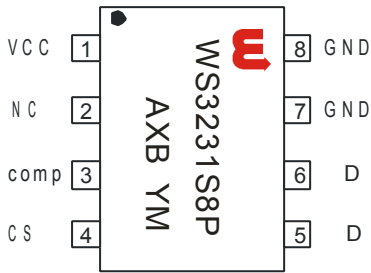

WS3231S8P: Product code
 A: Die Code
 X: Internal Code
 B: Area Code
 YM: Year, Month

Pin Function Description

Pin Name	Pin Number	Pin Type	Function Description
VCC	1	Power Supply	Power supply.
NC	2	NC	Floating
Comp	3	Loop Compensation	Loop compensation pin. Connect a RC network across this pin and ground to stabilize the control loop.
CS	4	Current Sense	Current sense. This pin connects a current sense resistor to GND to detect the primary current of transformer.
D	5/6	Drain	Drain of Power MOS
GND	7/8	Ground	Ground.

Block Diagram

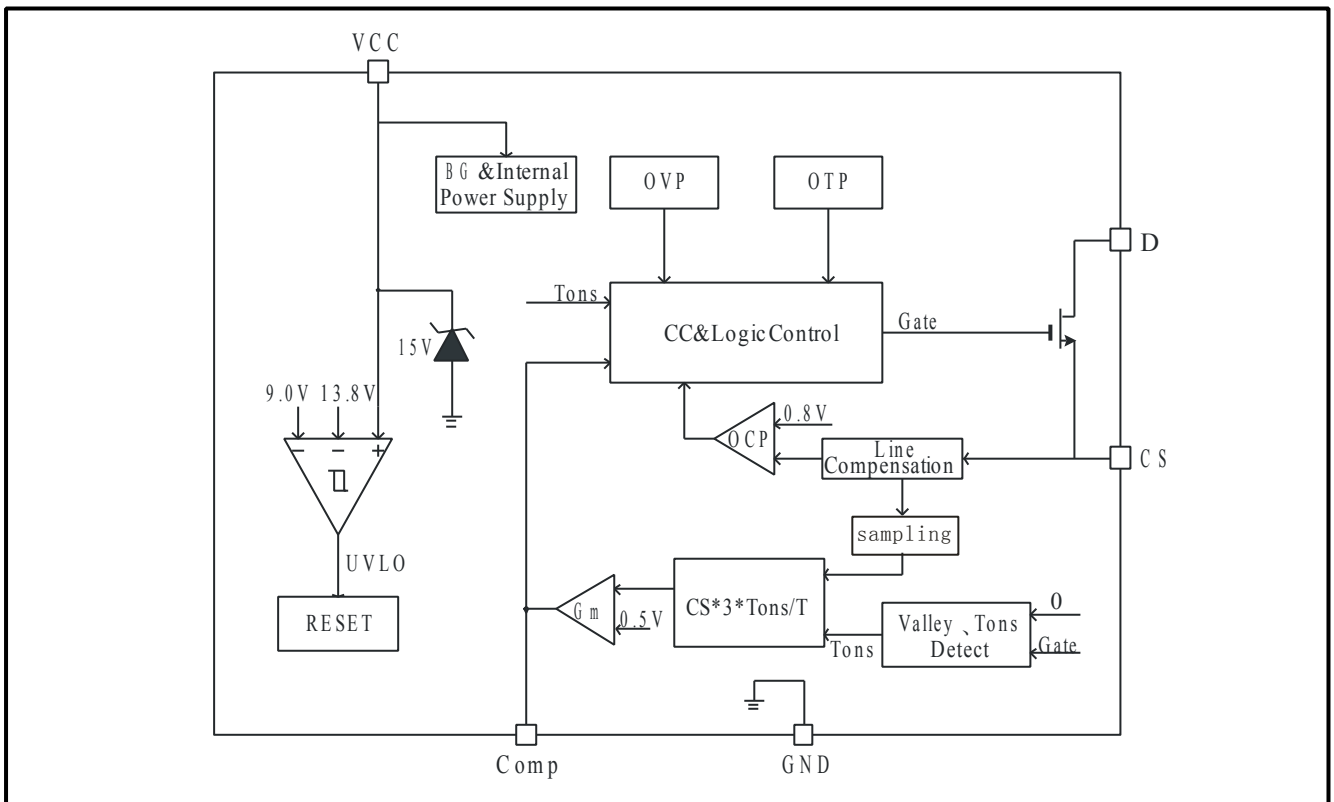

Ordering Information

Package	IC Marking Information	Purchasing Device Name
SOP-8, Pb-free	WS3231S8P	WS3231S8P

Recommended Operating Condition

Symbol	Parameter	Value	Unit
VCC	VCC supply voltage	9~14	V
T _A	Operating temperature	-20~85	°C
P _{out}	Output power	<5	W

Absolute Maximum Ratings

Symbol	Parameter	Value	Unit
I _{CC_max}	VCC pin maximum sink current	5	mA
D	Drain of power MOS	-0.3~600	V
CS	CS pin input voltage	-0.3~7	V
Comp	Comp pin input voltage	-0.3~7	V
T _J	Operating junction temperature	-40~150	°C
T _{STG}	Min./Max. Storage temperature	-55~150	°C

Note: Stresses above those listed under Absolute Maximum Ratings may cause permanent damage to the device. These are stress ratings only, functional operation of the device at these or any other conditions beyond those indicated in the Recommended Operating Conditions section are not implied. Exposure to absolute maximum-rated conditions for extended periods may affect device reliability.

Electrical Characteristics ($T_A=25^{\circ}\text{C}$, $V_{CC}=14\text{V}$, if not otherwise noted)

symbol	parameter	Test condition	Min	Typ	Max	Unit
Supply Voltage (VCC)						
I_VCC_ST	Start up current	VCC=UVLO_ON-1V		60	100	uA
I_OP	Operation Current	Fop=7Khz		300	400	uA
UVLO_ON	Turn on threshold Voltage	VCC rising		12.7		V
UVLO_OFF	Turn-off threshold Voltage	VCC falling		10		V
VCC_Clamp	VCC Clamp voltage	Icc=5mA		15		V
Current Sense Section						
TLEB	Leading edge Blanking Time			500		ns
V _{TH_OC}	OCP threshold		485	500	515	mV
Tdelay	Switch off delay time			200		ns
Frequency Section						
Ton_max	Max Primary On Time			24		us
Toff_max	Max Primary Off Time			224		us
Power MOS Section						
Rds_on	ON-resistor	V _{GS} =10V, I _D =0.5A			15	Ω
Vds_BD	Breakdown voltage	I _D =250μA	600			V
Over Temperature Protection						
Tsd	Thermal shutdown threshold			150		°C
Tsd_hys	Thermal shutdown hysteresis			25		°C

Function Description

WS3231 is a high PF offline QR PSR controller, optimized for low power LED driver. WS3231 operates in primary-side sensing and regulation. Consequently, opto-coupler and TL431 could be eliminated, thus reduce the cost.

Startup Current

Startup current of WS3231 is designed to as low as 60uA. The VCC capacitor will be charged through the start-up resistor when the system is powered on. Once the VCC voltage reaches the start-up threshold, the WS3231 will start to switch. The WS3231 integrates a 15V zener for VCC clamping. Due to the ultra-low operating current, the auxiliary winding is not need to supply the IC.

Quasi-Resonant Operation

Quasi-Resonant switching mode is applied in WS3231. When the voltage across drain and source of the primary MOSFET is at voltage valley, the MOSFET would be turned on, reducing the switching losses and improving EMI performance.

CC Operation

WS3231 is designed to produce good CC control characteristic. In DCM mode, the output current I_o can be represented by,

$$I_o = 0.5 * I_{ps} * T_{ons} / T$$

Where I_{ps} is the peak current of the secondary side; T_{ons} is the turn on time of secondary side; T is the switching period.

$$I_{ps} = I_{pp} * N_{ps} = (V_{cs} / R_{cs}) * N_{ps}$$

Where I_{pp} is the primary peak current; V_{cs} is the voltage on CS resistor; R_{cs} is primary current detection resistor; N_{ps} is the turns ratio of primary to secondary of the flyback transformer. The relationship of V_{cs} , T_{ons} and T is controlled to be constant by internal circuit, $3 * V_{cs} * T_{ons} / T = 0.5V$. Thus, I_o can be represented by,

$$I_o = 0.5 * (V_{cs} / R_{cs}) * N_{ps} * T_{ons} / T \\ = (V_{cs} * T_{ons} / T) * 0.5 * (N_{ps} / R_{cs})$$

$$= 0.083 * (N_{ps} / R_{cs})$$

Once the parameters of the transformer and the current sense resistor R_{cs} is determined, so is the output current. And the output current can be set by adjusting the current sense resistor R_{cs} .

Internal pre-charge design for quick start up

After VCC exceeds UVLO_ON, Vcomp is pre-charged by an internal current source. The PWM block will not start to output PWM signals until Vcomp is over 0.45V. Such design is meant to reduce the start up time. The voltage pre-charged Vcomp in start-up procedure can be programmed by,

$$V_{comp} = 0.4V - 300uA * R_{comp}$$

Where R_{comp} is the series resistor of Comp pin.

Operation switching frequency

The frequency of WS3231 is decided by load condition and QR mode. When the output power decreases, the switching frequency can become rather high. The maximum switching frequency in WS3231 is internally limited to 120Khz.

Current Sensing and Leading Edge Blanking

Cycle-by-Cycle current limiting is offered in WS3231. The switch current is detected by a sense resistor into the sense pin. An internal leading edge blanking circuit chops off the sense voltage spike at initial MOSFET on state due to snubber diode reverse recovery so that the external RC filtering on sense input is no longer required. The current limit comparator is disabled and thus cannot turn off the external MOSFET during the blanking period.

Protection Controls

Excellent system stability is achieved by the comprehensive protection of WS3231. Including Cycle-by-Cycle current limiting (OCP), LED open/short circuit protection, CS resistor short circuit protection, VCC



UVLO,OVP and Clamp, over temperature protection, and so on.

When the LED is open circuit, it will trigger over-voltage protection logic and latch, the system stops switching immediately; When the LED short circuit is detected, the system works at low frequency($F_{op}=5KHz$), so the power loss is low. At some catastrophic fault condition, such as shorted CS resistor or flyback transformer saturation, the internal fast fault detection circuit will trigger and latch, the system stops switching immediately.

After the system enters into fault latch condition, the VCC voltage will fall until it reaches UVLO threshold. Then the system will re-start again. If the fault condition is removed, the system will recover to normal operation. The thermal

shutdown circuitry in the WS3231 senses the die temperature after start up, and the thermal protection threshold is set to $150^{\circ}C$ with a $25^{\circ}C$ hysteresis. When the temperature on die of WS3231 rises and reaches the threshold, the power MOSFET will be shut down immediately and maintained switch off until the temperature on die falls $25^{\circ}C$ from thermal protection trigger point.

SOP-8 Package Information

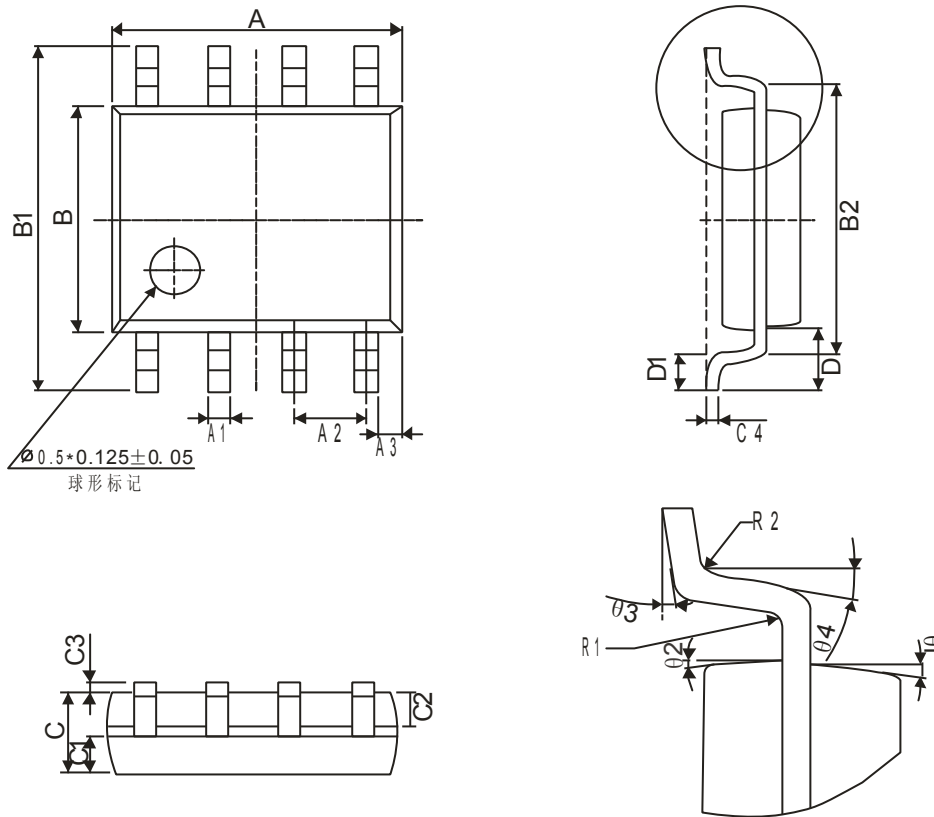

Symbol	Winsemi			
	Dimensions in Millimeters		Dimensions in Inches	
	Min	Max	Min	Max
A	4.70	5.10	0.185	0.201
B	3.70	4.10	0.146	0.161
C	1.30	1.50	0.051	0.059
A1	0.35	0.48	0.014	0.019
A2	1.27TYP		0.05TYP	
A3	0.345TYP		0.014TYP	
B1	5.80	6.20	0.228	0.244
B2	5.00TYP		0.197TYP	
C1	0.55	0.70	0.022	0.028
C2	0.55	0.70	0.022	0.028
C3	0.05	0.225	0.002	0.009
C4	0.203TYP		0.008TYP	
D	1.05TYP		0.041TYP	
D1	0.40	0.80	0.016	0.031