

WS3412 Active PFC Non-isolated Buck LED Driver

Features

- High Power Factor Correction, Low Total Harmonic Distortion
- Dynamic Temperature Compensation
- 550V Power MOSFET Integrated
- No Auxiliary Winding For Supplying
- SOP8 Package, Up To 260mA Output Current
- Valley Switching, High efficiency, Low EMI
- Automatic Compensate the Inductance Variation
- Automatic Adapt to the Change of Output Voltage
- LED Short Circuit Protection
- Over Voltage Protection
- Over Temperature Protection
- Open Circuit Protection
- Few External Components

General Description

The WS3412 is designed for active PFC non-isolated buck LED driver. It operates at valley switching mode with high efficiency, low EMI and High PF. The output current automatically adapt to the variation of the inductance and the output voltage. The truly constant current LED is realized.

The WS3412 integrates 550V power MOSFET, using SOP 8 package, producing up to 260mA output current. It can achieve excellent constant current performance with very few external components.

The WS3412 offers rich protection functions, including over voltage protection, LED short circuit protection, cycle by cycle current limiting, dynamic temperature compensation, over temperature protection and soft start.

WS3412 consumes very low start current and operation current, driving LED efficiently under universal AC input(85VAC~265VAC).

WS3412 is available in SOP8 package.

Applications

- LED Driver Supply

Typical Application Circuit

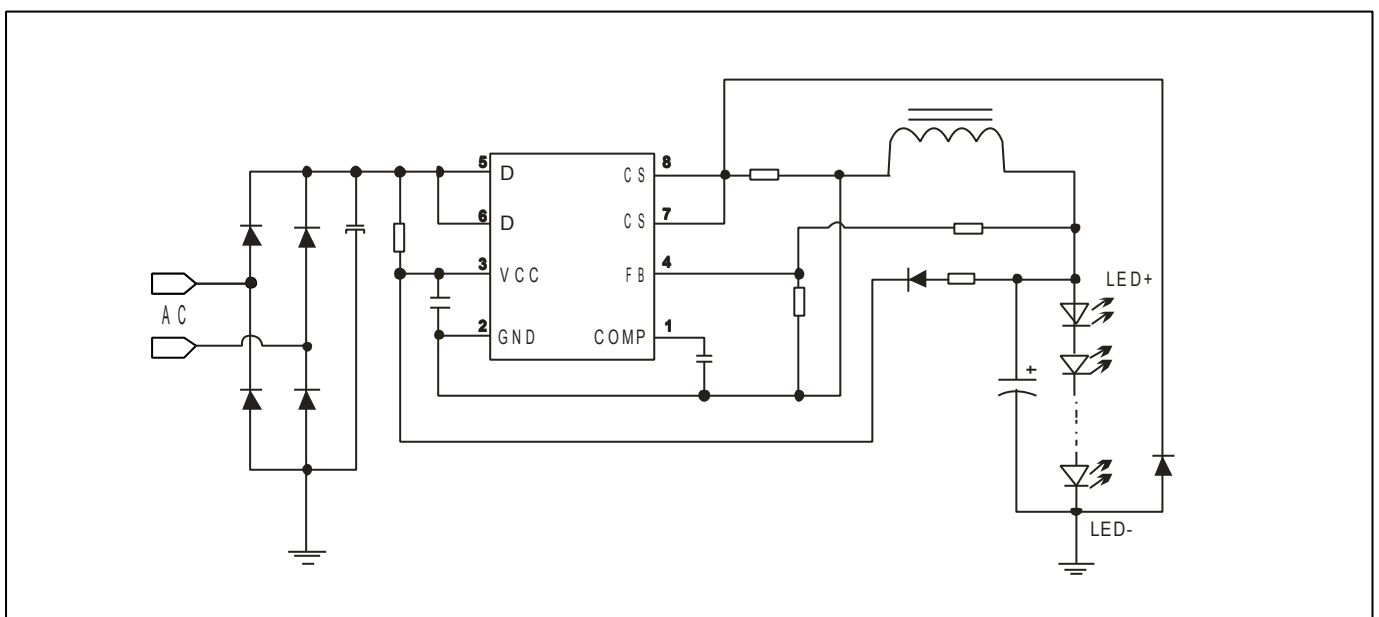

Pin Definition and Device Marking

WS3412 is available in SOP-8 package.

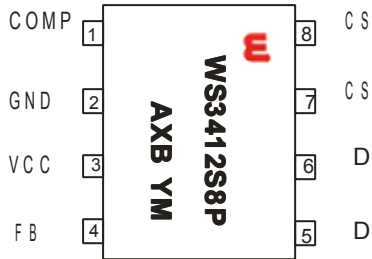

WS3412S8P: Product code
 A: Product Code
 X: Internal Code
 B: Area Code
 YM: Year, Month

Pin Function Description

Pin Name	Pin NO.	Description
COMP	1	Loop compensation, with a cap to GND.
GND	2	Ground
VCC	3	Power supply
FB	4	Feedback signal input.
D	5	Internal HV power MOSFET drain
D	6	Internal HV power MOSFET drain
CS	7	Current sense input, connect to internal HV power MOSFET source
CS	8	Current sense input, connect to internal HV power MOSFET source

Block Diagram

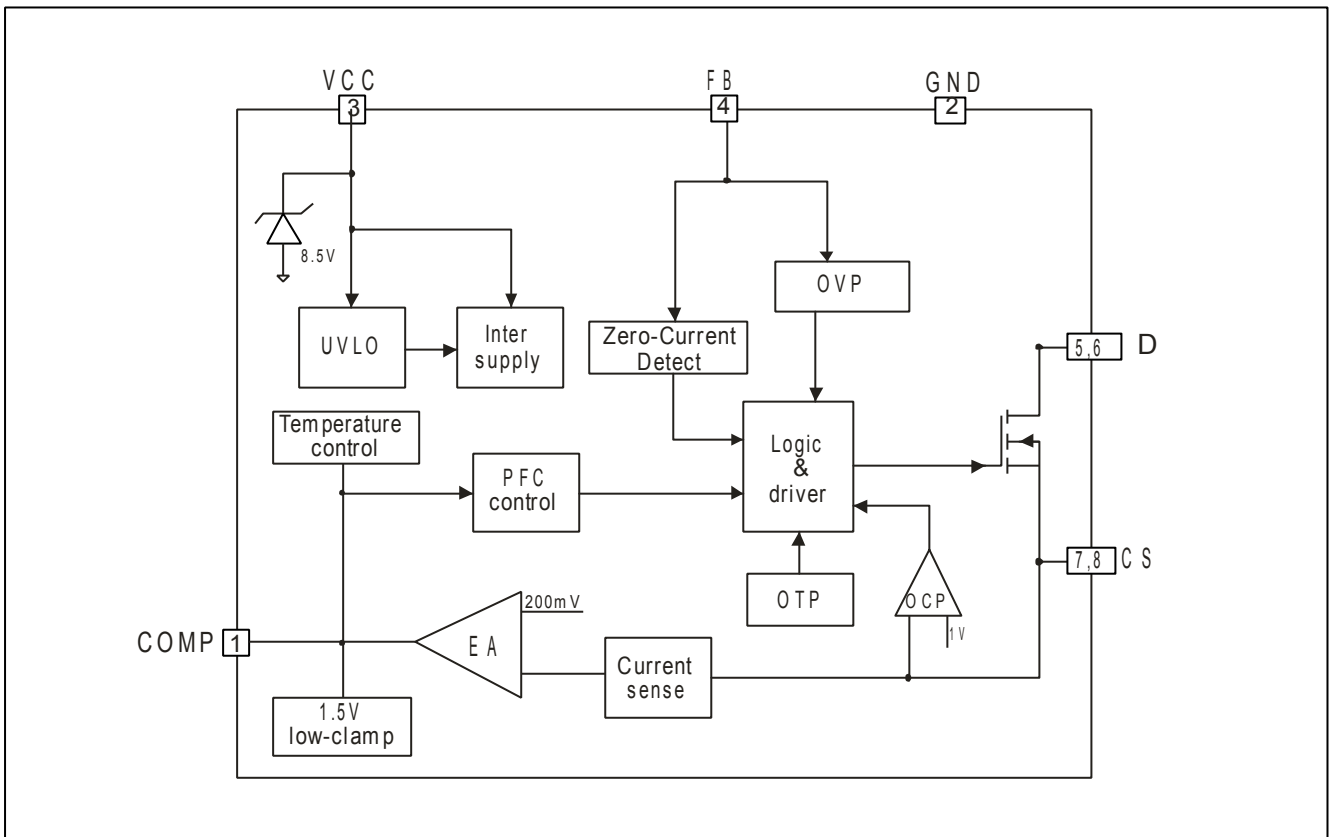

Ordering Information

Package	Part Number	Marking
8-Pin SOP-8, Pb-free	WS3412S8P	WS3412S8P

Recommended Operating Condition

symbol	parameter	value	units
I _{LED}	Output LED current	< 260	mA

Absolute Maximum Ratings

symbol	parameter	Range	Units
V _{DS}	Internal HV MOSFET drain voltage	-0.3~550	V
V _{CC}	Power Supply	-0.3~8.5	V
V _{CS}	Current sense pin input voltage	-0.3~7	V
V _{FB}	Feedback voltage input	-0.3~7	V
V _{COMP}	Loop Compensation Pin voltage	-0.3~7	V
P _{DMAX}	Power dissipation	0.5	W
T _J	Max. Operating junction temperature	150	°C
T _{STG}	Max./Min. Storage temperature range	-55~150	°C

Note: Stresses beyond those listed under “absolute maximum ratings” may cause permanent damage to the device. Under “recommended operating conditions” the device operation is assured, but some particular parameter may not be achieved.

Electrical Characteristics (Unless otherwise specified, $T_A=25^{\circ}\text{C}$, $V_{CC}=8\text{V}$)

Symbol	Parameter	Conditions	Min	Typ	Max	Units
Supply Voltage Section						
Vcc_clamp	VCC Clamping Voltage		7.8	8.5	9.3	V
Icc_clamp	VCC Clamping Current				5	mA
VCC_ST	VCC Start Up Voltage	VCC Rise		7.5		V
Vuvlo_HYS	VCC Under Voltage Latch Out Hysteresis	VCC Falling		1.5		V
Ist	Start Up Current	$V_{CC} < V_{CC_ST} - 0.5\text{V}$		70	100	μA
Iop	Operation Current			400		μA
Current Sensor Section						
Vocp	Current Sensor Voltage Threshold			1		V
TLEB	Leading Edge Blanking			350		ns
TDELAY	Turn Off Delay Time			200		ns
Loop Compensation Section						
VREF	Internal Reference Voltage		194	200	206	mV
VCL	Comp Low Clamp Voltage			1.5		V
VCH				4		V
Internal Driver Section						
Toff_min	Min. Demagnetization Time			3		μs
Ton_max	Max. On Time			20		μs
Feedback input Section						
VFB	OVP Threshold Voltage			1.6		V
VZCD	Zero Crossing Checking Threshold			0.2		V
Internal HV MOSFET						
RDSON	HV MOS ON Resistance				6.5	ohm
VDS	Drain to Source voltage		550			V
Over Temperature Section						
TSD	Thermal Shut Down Temperature			160		$^{\circ}\text{C}$
TSD_HYS	Thermal Shut Down Hysteresis			30		$^{\circ}\text{C}$

Function Description

The WS3412 is designed for active PFC non-isolated buck LED driver, which integrates 550V power MOSFET and using SOP 8 package, producing up to 260mA output current. It operates under valley switching mode, automatically adapting to the variation of the inductance and the output voltage.

It can achieve excellent constant current performance with very few external components.

Start up

The start current is very low, Typ. 70uA(Max. 100uA). Under the design system of 85VAC, the startup resistor is:

$$R = \frac{85 * \sqrt{2}}{100} = 1.2M$$

Chip Supply

After startup, the output voltage should supply the chip, rectifier diodes D6 need to use fast recovery diodes. Current limiting resistor R4 is calculated as:

$$R_4 = (1 - D) * \frac{V_{LED} - 9}{400\mu A}$$

Where, D is duty cycle, 400uA is the normal operation current of the chip, Vled is output load voltage. The consumption of R4 is:

$$P_{R4} = \frac{(V_{LED} - 9)^2}{R_4} * (1 - D)$$

For example:

Requirements: 180~260V input voltage, 36~80V output, 240mA output current.

The R4 design of above program should be met:

1. Supply Problem when Min. input AC voltage 180V and Min. output voltage 36V(which is the weakest power supply):
 $D = 36/180/1.414 = 0.141, R4 = (1 - 0.141) * (36 - 9)/400\mu A = 58k$
2. Power consumption problem of R4 when Max. input AC voltage 260V and Max. output voltage 80V(which is the

strongest power supply):

$$D = 80/260/1.414 = 0.218$$

The power consumption of R4:

$$P = (80 - 9) * (80 - 9) / 58 * (1 - 0.218) = 68mW$$

Sence Resistor

The WS3412 is designed for active PFC non-isolated buck LED driver. It operates under valley switching mode and can achieve high accuracy constant current performance with very few external components. The peak current of inductor is continuous detected. CS terminal is connected internal of the chip, and compared with the internal 200mV. Internal Amplifier's output COMP adjust the on-time, making the average value os CS equal to 200mV after the system is stable. In addition, a 1V cycle-by-cycle over current protection is set up inside CS pin.

LED output current:

$$I_{LED} = \frac{0.2V}{R_{CS}}$$

FB Voltage Detection

FB voltage determines the working status of the system, when FB is greater then 1.6V(typ.), WS3412 will automatically considered as output over voltage protection. The system will enter extremely energy efficient hiccup mode. Output over voltage protection voltage as follows:

$$V_{OVP} = 1.6 * \frac{R_2 + R_3}{R_3}$$

R2,R3,please refer to the typical application diagram, in which R3=1k(no more than 2k). use 1.3 instead of constant 1.6 in the above formula in the design of system. Assuming Vovp=90V, we got R2=56k from the above formula, choosing 60k for R2 (larger as far as possible).

Because VFB2 is between 1.3 and 1.9, choose 1.9 to calculate the withstand voltage of C4,

$$V_{ovp} = 1.9 * (1 + 60) / 1 = 116V$$

The withstand voltage of C4 shoule larger than the above value, 200V capacitor could be used.

The WS3412 uses the patent source driver structure. The typical operation current is as low as 200uA, the auxiliary winding is not need. So the system design is simple and the cost is low.

WS3412 will automatic detect the output voltage when enters hiccup mode; and will re-enter the normal working state when the output voltage is lower than V_{ovp} .

Output Open(Short) protection

Output open/short protection is integrated inside WS3412. Once output open/short circuit is detected, the system will automatic enter hiccup mode until the protection signal disappear.

Over Temperature Automatic adjustment of output current

WS3412 has over temperature regulating function, gradually reducing the output current when the power is over temperature, so as to control the output power and the temperature rise, keeping the power temperature in a setting value in order to improving the reliability of the system. The starting regulation temperature is 135°C.

Input Filter Capacitor

In order to obtain high PF value, the input capacitor can not be too large. 10-100nF is recommended.

Power Factor Correction

Active PFC control circuit is integrated in WS3412, which can get high PF value and low THD.

PCB Design

The following guidelines should be followed in WS3412 PCB layout:

Bypass Capacitor: The bypass capacitor on VCC pin should be as close as possible to the VCC and GND pins.

Ground Path: The power ground path for current sense should be short, and the power ground path should be separated from small signal ground path before the negative node of the bulk capacitor.

The Area of Power Loop: The area of power loop should be as small as possible to reduce EMI radiation.

And the controller should be placed away from the heat generator, such as the power diode.

Package Information
SOP-8 Package Outline Dimensions

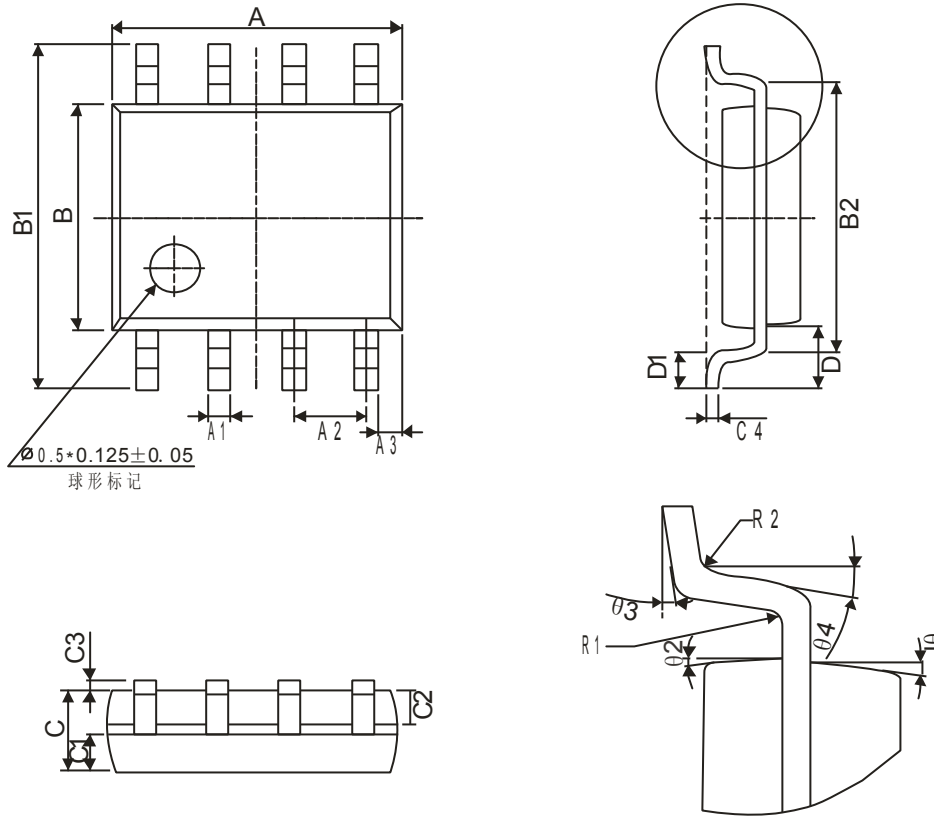

Winsemi				
Symbol	Dimensions in Millimeters		Dimensions in Inches	
	Min	Max	Min	Max
A	4.70	5.10	0.185	0.201
B	3.70	4.10	0.146	0.161
C	1.30	1.50	0.051	0.059
A1	0.35	0.48	0.014	0.019
A2	1.27TYP		0.05TYP	
A3	0.345TYP		0.014TYP	
B1	5.80	6.20	0.228	0.244
B2	5.00TYP		0.197TYP	
C1	0.55	0.70	0.022	0.028
C2	0.55	0.70	0.022	0.028
C3	0.05	0.225	0.002	0.009
C4	0.203TYP		0.008TYP	
D	1.05TYP		0.041TYP	
D1	0.40	0.80	0.016	0.031

NOTE:

- 1.We strongly recommend customers check carefully on the trademark when buying our product, if there is any question, please don't be hesitate to contact us.
- 2.Please do not exceed the absolute maximum ratings of the device when circuit designing.
- 3.Winsemi Microelectronics Co., Ltd reserved the right to make changes in this specification sheet and is subject to change without prior notice.

CONTACT:

Winsemi Microelectronics Co., Ltd.

ADD:Futian District, ShenZhen Tian An Cyber Tech Plaza two East Wing 1002

Post Code : 518040

Tel : 86-0755-82506257

FAX : 86-0755-82506299

Web Site : www.winsemi.com