

WS4518E

300mA, Single Li-ion Battery Charger

www.sh-willsemi.com

Descriptions

The WS4518E is a complete constant-current / constant voltage linear charger for single cell Lithium-Ion batteries. No external sense resistor is needed, and no blocking diode is required due to the internal MOSFET architecture. Thermal feedback regulates the charge current to limit the die temperature during high power operation or high ambient temperature. The charge voltage is fixed at 4.2V, and the charge current can be programmed externally with a single resistor.

The WS4518E automatically terminates the charge cycle when the charge current drops to 3/10 the programmed value after the final float voltage is reached.

When the input supply (wall adapter or USB supply) is removed, the WS4518E automatically enters a low current state, dropping the battery drain current to less than 0.5uA. The WS4518E can be put into shutdown mode, reducing supply current to 40uA (Typ.).

The WS4518E is available in a small package with SOT-23-5L. Standard product is Pb-Free.

Features

- Programmable Charge Current Up to 300mA
- Over-Temperature Protection
- Under Voltage Lockout Protection
- Automatic Recharge Threshold 4.05V(Typ.)
- Charge Status Output Pin
- 2.9V Trickle Charge Threshold
- Soft-Start Limits Inrush Current

Applications

- Wireless phone
- MP3/MP4 Player
- Bluetooth device



SOT-23-5L

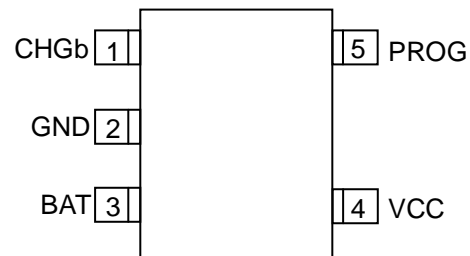

Pin configuration (Top view)

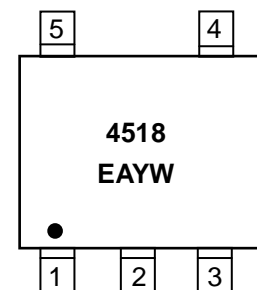

4518 = Device Code
EA = Package Code
Y = Year
W = Week
Marking

Order information

Device	Package	Shipping
WS4518E-5/TR	SOT-23-5L	3000/Reel&Tape

Typical applications

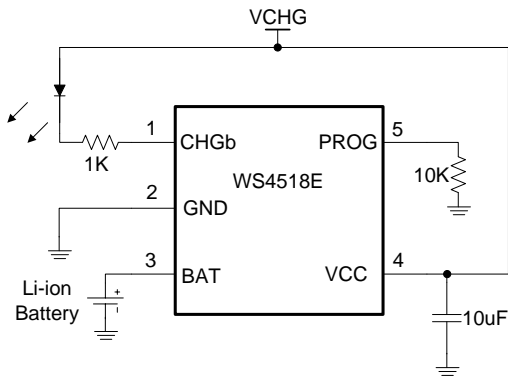
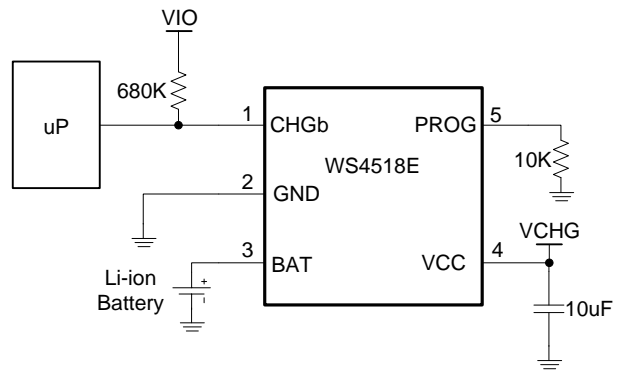
Typical applications W/T LED indicate

Typical applications W/T microprocessor detect

Pin descriptions

Pin Number	Pin Name	Function
1	CHGb	Open-Drain Charge Status Output. When the battery is charging, the CHGb pin is pulled low. When the charge cycle is completed or VCC is removed, the CHGb is forced high impedance.
2	GND	Ground
3	BAT	Charge Current Output. Provides charge current to the battery and regulates the final float voltage to 4.2V.
4	VCC	Power Supply
5	PROG	Charge current setting, charge current monitor and shutdown pin. The charging current is given by $I_{BAT} = (1/R_{PROG}) * 1000$. The chip will be shutdown when PROG pin floating

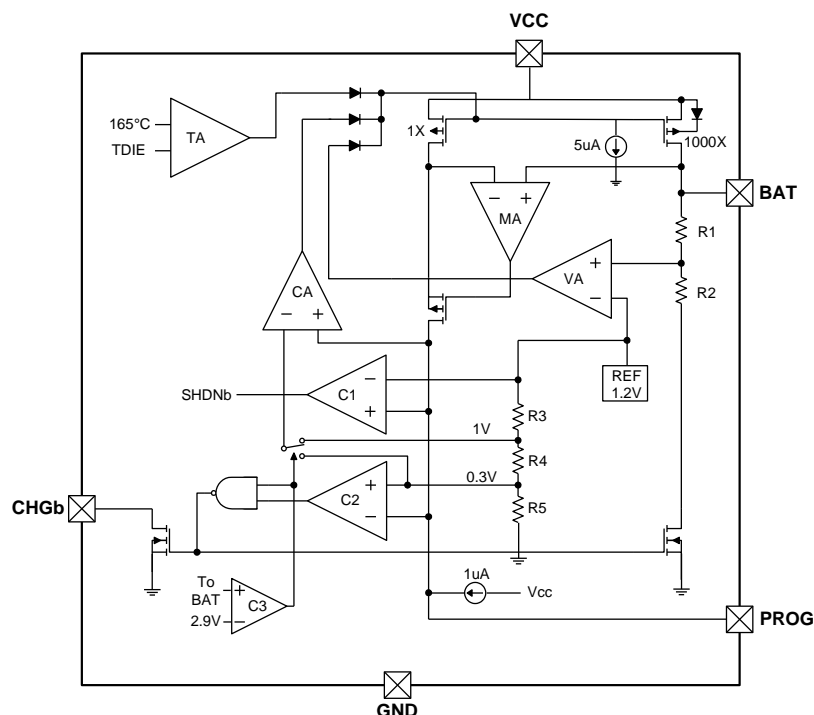
Block Diagram



Absolute Maximum ratings

Parameter	Symbol	Rating	Unit
Supply Voltage	VCC	-0.3~8	V
PROG Voltage	V _{PROG}	-0.3~VCC	V
BAT Voltage	V _{BAT}	-0.3~8	V
CHGb Voltage	V _{CHGb}	-0.3~VCC	V
BAT Pin Current	I _{BAT}	600	mA
Power Dissipation – Note1	Pd	0.5	W
Power Dissipation – Note2	Pd	0.3	W
Junction Temperature	T _j	150	°C
Operation Temperature	Top	-45~85	°C
Storage Temperature	T _{sg}	-65~125	°C
Lead Temperature (Soldering 10s)		260	°C

Thermal resistance characteristics

Symbol	Parameter	Max.	Unit
R _{θJA1}	Thermal Resistance, Junction to Ambient – Note1	125	°C/W
R _{θJA2}	Thermal Resistance, Junction to Ambient – Note2	415	°C/W

Note1: Surface mounted on FR4 Board using 1 in sq pad size, 2oz Cu.

Note2: Surface mounted on FR4 board using the minimum recommended pad size, 2oz Cu.

Electronics Characteristics (V_{CC}=5V, T_a=25°C, unless otherwise noted)

Symbol	Parameter	Condition	Min.	Typ.	Max.	Unit
I _{SPLYCHRG}	Charge Mode Supply Current	R _{PROG} =10kΩ		220	2000	μA
		R _{PROG} =20kΩ		170	2000	μA
I _{BATCHRG}	Charge Mode Battery Current	R _{PROG} =10kΩ	90	100	110	mA
		R _{PROG} =20kΩ	44	49	54	mA
		R _{PROG} =33.3kΩ	25	28.5	32	mA
V _{PROGCHRG}	PROG Pin Voltage	R _{PROG} =10kΩ	0.93	1.00	1.07	V
		R _{PROG} =20kΩ	0.93	1.00	1.07	V
I _{SPLYSTBY}	Standby Mode Supply Current	Charge Terminated		130	500	μA
I _{BATSTBY}	Standby Mode Battery Current	Charge Terminated	0	-2.5	-6	μA
I _{SPLYASD}	Shutdown Mode Supply Current	V _{CC} <V _{BAT}	20	40	90	μA
I _{BATASD}	Shutdown Mode BAT Pin Current	V _{CC} <V _{BAT}		±0.05	±1	μA
I _{SPLYUVLO}	UVLO Mode Supply Current	V _{CC} <V _{UV}	20	40	90	μA
I _{BATUVLO}	UVLO Mode BAT Pin Current	V _{CC} <V _{UV}		±0.05	±1	μA
I _{SPLYSHUT}	Shutdown Mode Supply Current	R _{PROG} not Connected	20	40	70	μA
I _{BATSHUT}	Shutdown Mode BAT Pin Current	R _{PROG} not Connected		±0.05	±1	μA
I _{BATMSD}	Manual Shutdown BAT Pin Current	V _{PROG} =1.3V		±0.05	±1	μA
I _{BATSLEEP}	Sleep Mode BAT Pin Current	V _{CC} =0V		±0.05	±1	μA
V _{FLOAT}	Float Voltage		4.158	4.2	4.242	V
I _{TRIKL}	Trickle Charge Current	R _{PROG} =10kΩ	19	29	39	mA
V _{TRIKL}	Trickle Charge Voltage Threshold	R _{PROG} =10kΩ	2.8	2.9	3.0	V
V _{TRIKL, HYS}	Trickle Charge Voltage Hysteresis	R _{PROG} =10kΩ		100		mV
V _{UVLO}	UVLO Threshold	From V _{CC} Low to High	3.6	3.8	4.0	V
V _{UVLO, HYS}	UVLO Hysteresis			250		mV
V _{MSD}	Manual Shutdown Threshold Voltage	PROG Pin Rising		1.2	1.3	V
		PROG Pin Falling		1.0		V
V _{ASD}	V _{CC} -V _{BAT} Lockout Threshold Voltage	V _{CC} from Low to High		120		mV
		V _{CC} from High to Low	5	50		mV
ΔV _{RECHRG}	Auto Recharge Battery Voltage		100	150	200	mV
V _{CHGb}	CHGb Pin Output Low Voltage	I _{CHGb} =5mA		0.3	0.6	V
T _{LIM}	Junction Temperature In Constant Temperature Mode			165		°C
R _{ON}	Power FET ON Resistance			200		mΩ
T _{SS}	Soft-Start Time	R _{PROG} =2kΩ		100		μs
T _{RECHRG}	Recharge Comparator Filter Time			2		ms
T _{TERM}	Termination Comparator Filter Time			1		ms
I _{PROG}	PROG Pin Pull-up Current		0.7	1.1	1.5	μA

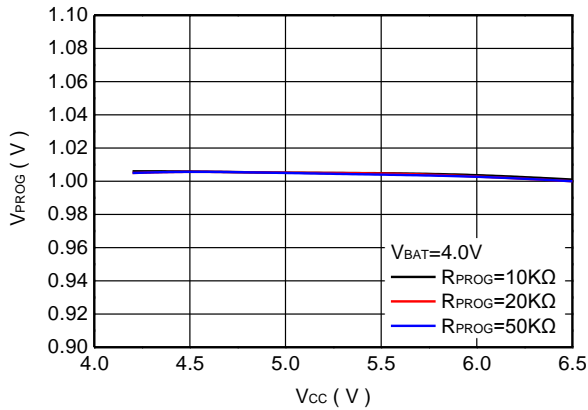
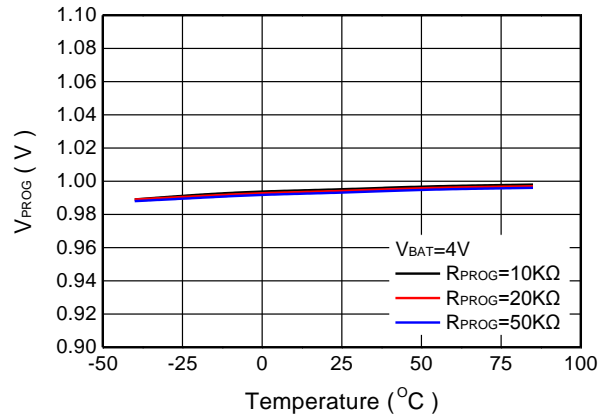
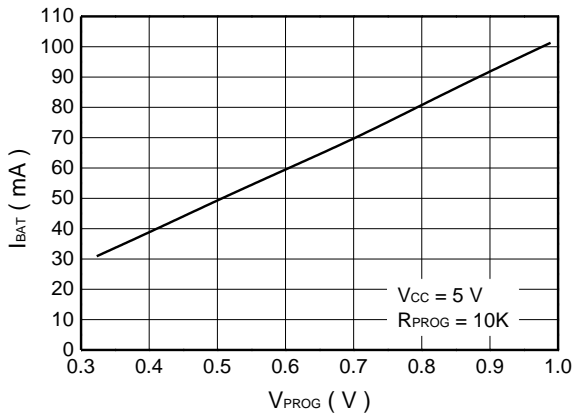
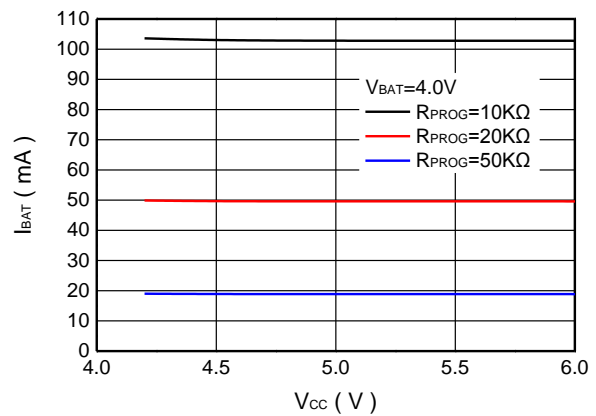
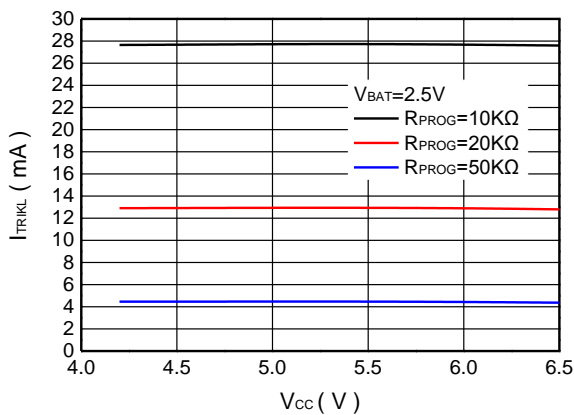
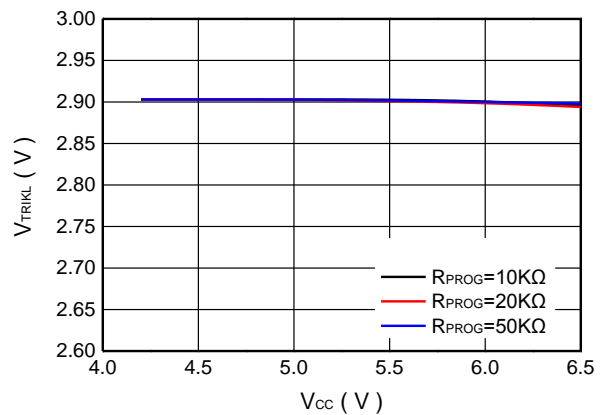
Typical Characteristics (Ta=25°C, unless otherwise noted)

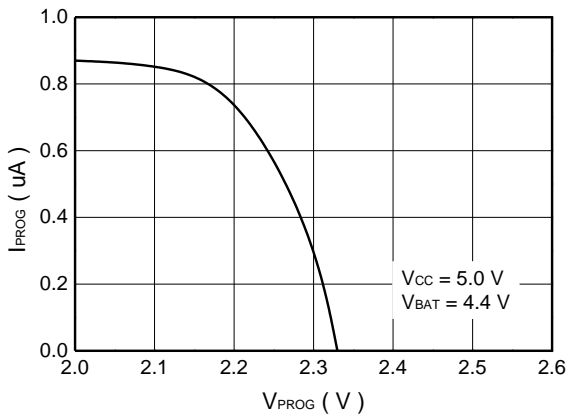
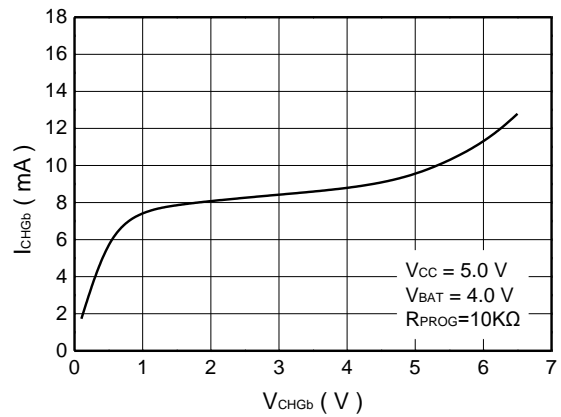
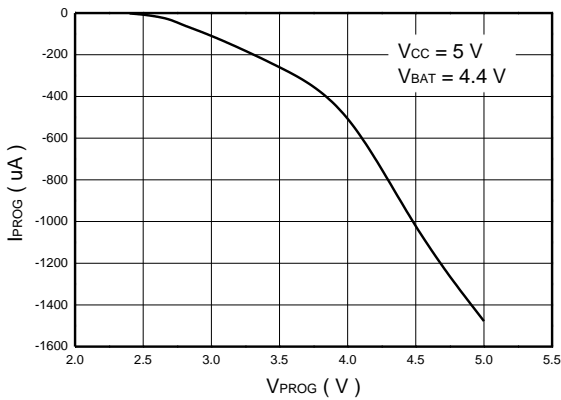
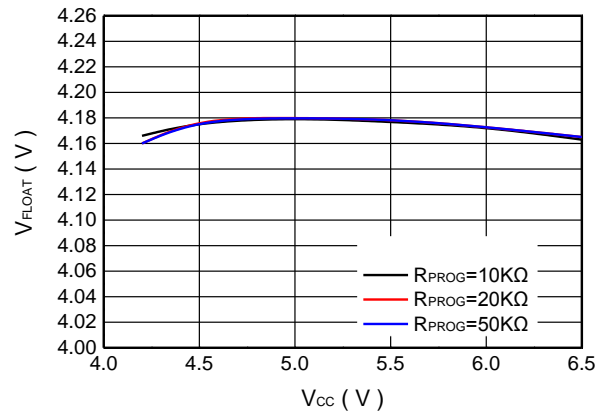
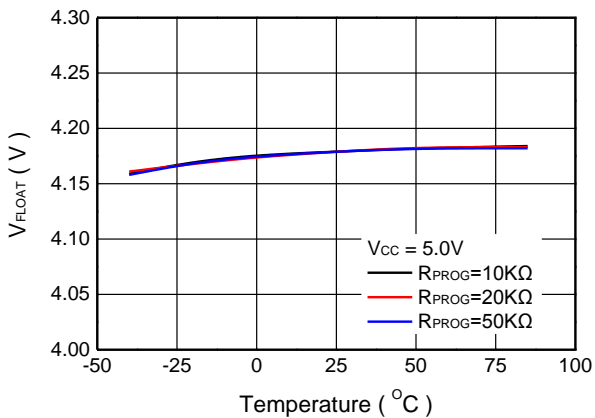
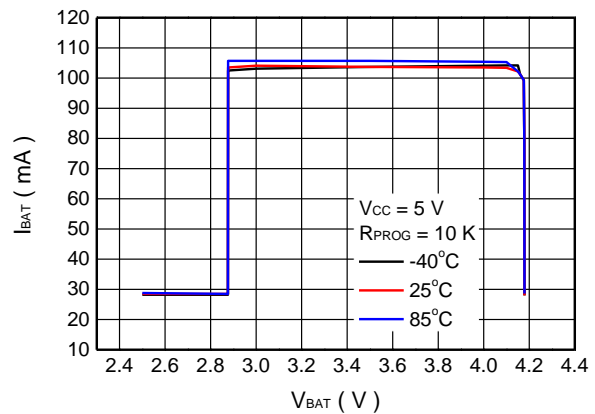
PROG Pin Voltage vs Supply Voltage

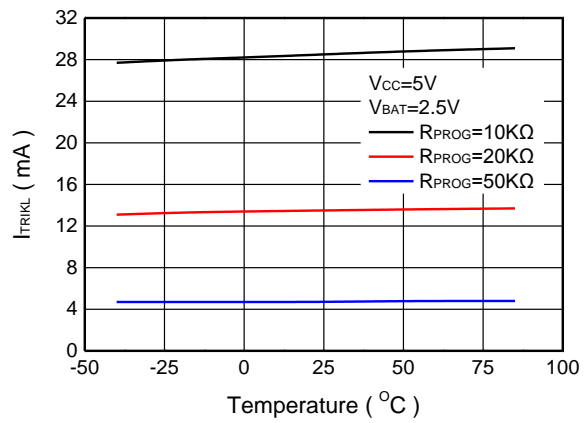
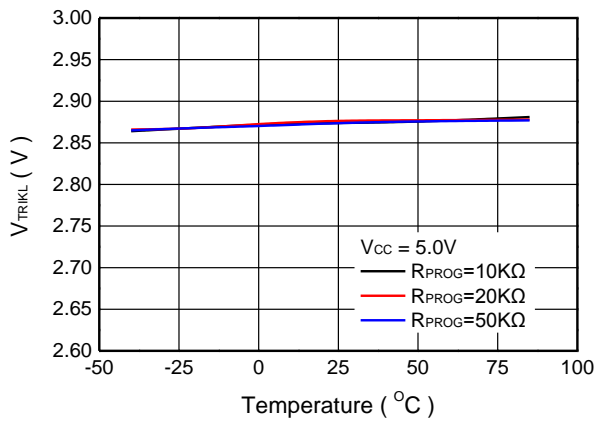
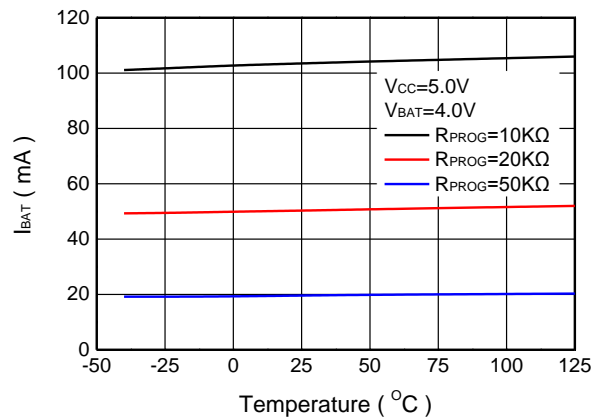
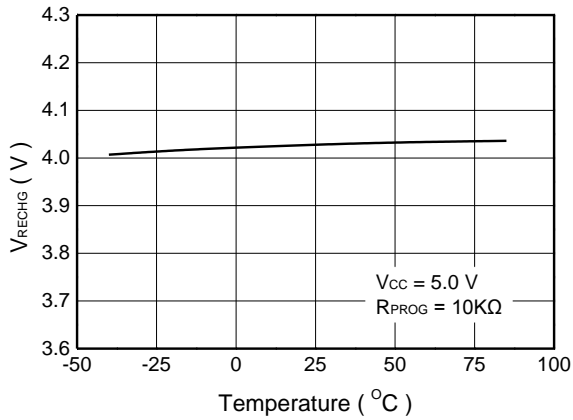
PROG Pin Voltage vs Ambient Temperature

Charge Current vs PROG Pin Voltage

Charge Current vs Supply Voltage

Trickle Charge Current vs Supply Voltage

Trickle Voltage vs Supply Voltage

PROG Pin Pull-Up Current vs PROG Pin Voltage

CHGb Pin Current vs CHGb Pin Voltage

PROG Pin Clamp Current vs PROG Pin Voltage

Float Voltage vs Supply Voltage

Float Voltage vs Ambient Temperature

Charge Current vs Battery Voltage

Trickle Charge Threshold vs Ambient Temperature Trickle Charge Current vs Ambient Temperature

Recharge Voltage Threshold vs Ambient Temperature Charge Current vs Ambient Temperature

Operation Information

The WS4518E is a single cell Lithium-Ion battery charger using a constant-current / constant-voltage algorithm. It can deliver up to 0.3A of charge current (using a good thermal PCB layout) with a final float voltage accuracy of $\pm 1\%$. The WS4518E includes an internal P-channel power MOSFET and thermal regulation circuitry. No blocking diode or external current sense resistor is required; thus, the basic charger circuit requires only two external components. Furthermore, the WS4518E is capable of operating from a USB power source.

Normal charge cycle

A charge cycle begins when the voltage at the VCC pin rises above the UVLO threshold level and a 1% program resistor is connected from the PROG pin to ground or when a battery is connected to the charger output. If the BAT pin is less than 2.9V, the charger enters trickle charge mode. In this mode, the WS4518E supplies approximately 3/10 the programmed charge current to bring the battery voltage up to a safe level for full current charging.

When the BAT pin voltage rises above 2.9V, the charger enters constant-current mode, where the programmed charge current is supplied to the battery. When the BAT pin approaches the final float voltage, the WS4518E enters constant-voltage mode and the charge current begins to decrease. The charge cycle ends when the PROG voltage is less than 300mV.

Programming charge current

The charge current is programmed using a single resistor from the PROG pin to ground. The battery charge current of constant current mode is 1000 times the current out of the PROG pin. The program resistor and the charge current of constant current are calculated using the following equations:

$$I_{CHG} = (1V/R_{PROG}) * 1000$$

Charge termination

A charge cycle is terminated when the charge current falls to 3/10 of the programmed value after the final float voltage is reached. This condition is detected by using an internal, filtered comparator to monitor the PROG pin. When the PROG pin voltage falls below 300mV for longer than T_{TERM} (typically 1ms), charging is terminated. The charge current is latched off and the WS4518E enters standby mode, where the input supply current drops to 130uA. (Note: 3CC/10 termination is disabled in trickle charging mode and thermal limiting modes).

When charging, transient loads on the BAT pin can cause the PROG pin to fall below 300mV for short periods of time before the DC charge current has dropped to 3/10 of the programmed value. The 1ms filter time (T_{TERM}) on the termination comparator ensures that transient loads of this nature do not result in premature charge cycle termination. Once the average charge current drops below 3/10 of the programmed value, the WS4518E terminates the charge cycle and ceases to provide any current through the BAT pin, the chip will be put into standby mode. In this state, all loads on the BAT pin must be supplied by the battery.

The WS4518E constantly monitors the BAT pin voltage in standby mode. If this voltage drops below the 4.05V recharge threshold (V_{RECHRG}), another charge cycle begins and current is once again supplied to the battery. The state diagram of a typical charge cycle is as below:

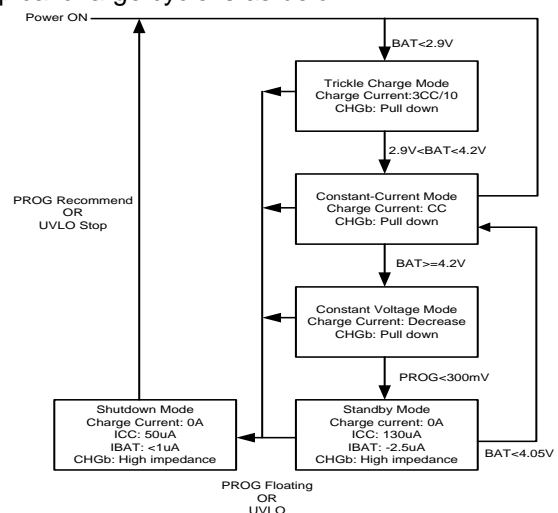

Charge status indicator (CHGb)

The charge status output indicator is an open drain circuit. The indicator has two different states: pull-down (~10mA), and high impedance. The pull-down state indicates that the WS4518E is in a charge cycle. High impedance indicates that the charge cycle is complete. The CHGb also can be used to detect the charge states by a microprocessor with a pull-up resistor.

Shutdown mode

At any point in the charge cycle, the WS4518E can be put into shutdown mode by removing RPROG thus floating the PROG pin. This reduces the battery drain current to less than 0.5uA and the supply current to less than 45uA. A new charge cycle can be initiated by reconnecting the program resistor. Below is a recommend application.

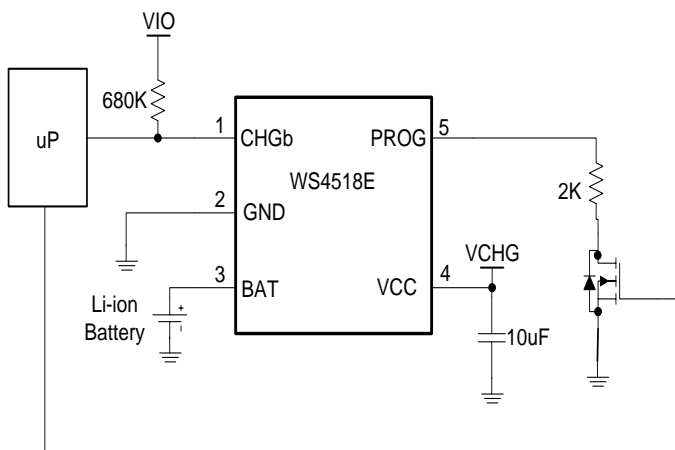

The WS4518E also be put into shutdown mode when VCC voltage down to UVLO Threshold. In this state, the CHGb pin is high impedance state. The CHGb pin is also in a high impedance state if the charge cycle is completed.

Automatic recharge

Once the charge cycle is terminated, the WS4518E continuously monitors the voltage on the BAT pin using a comparator with a 2ms filter time (T_{RECHRG}). A charge cycle restarts when the battery voltage falls below 4.05V (which corresponds to approximately 80% to 90% battery capacity). This ensures that the battery is kept at or near a fully charged condition and eliminates the need for periodic charge cycle initiations. CHGb output enters a pull-down state during recharge cycles.

Application informations

Stability considerations

The constant-voltage mode feedback loop is stable without an output capacitor provided a battery is connected to the charger output. With no battery present, an output capacitor is recommended to reduce ripple voltage. When using high value, low ESR ceramic capacitors, it is recommended to add a 1Ω resistor in series with the capacitor. No series resistor is needed if tantalum capacitors are used.

In constant-current mode, the PROG pin is in the feedback loop, not the battery. The constant-current mode stability is affected by the impedance at the PROG pin. With no additional capacitance on the PROG pin, the charger is stable with program resistor values as high as 50KΩ. However, additional capacitance on this node reduces the maximum allowed program resistor thus it should be avoided.

Thermal limit

An internal thermal feedback loop reduces the programmed charge current if the die temperature attempts to rise above a preset value of approximately 160°C. This feature protects the WS4518E from excessive temperature and allows the user to push the limits of the power handling capability of a given circuit board without risk of damaging the WS4518E. The charge current can be set according to typical (not worst-case) ambient temperature with the assurance that the charger will automatically reduce the current in worst-case conditions.

Power dissipation

The conditions that cause the WS4518E to reduce charge current through thermal feed-back can be approximated by considering the power dissipated in the IC. Nearly all of this power dissipation is generated by the internal MOSFET. This is calculated to be approximately:

$$P_D = (V_{CC} - V_{BAT}) \cdot I_{BAT}$$

It is important to remember that WS4518E applications do not be designed for worst-case thermal conditions since the IC will automatically reduce power dissipation when the junction temperature reaches approximately 160°C (Constant temperature mode).

VCC bypass capacitor

Many types of capacitors can be used for input bypass, however, caution must be exercised when using multilayer ceramic capacitors. Because of the self-resonant and high Q characteristics of some types of ceramic capacitors, a 10uF/16V ceramic capacitor is recommended for this bypass capacitor. Due to a high voltage transient will be generated under some start-up conditions, such as connecting the charger input to a live power source.

Charge current soft-start

The WS4518E includes a soft-start circuit to minimize the inrush current at the start of a charge cycle. When a charge cycle is initiated, the charge current ramps from zero to the full-scale current over a period of approximately 100us. This has the effect of minimizing the transient current load on the power supply during start-up.

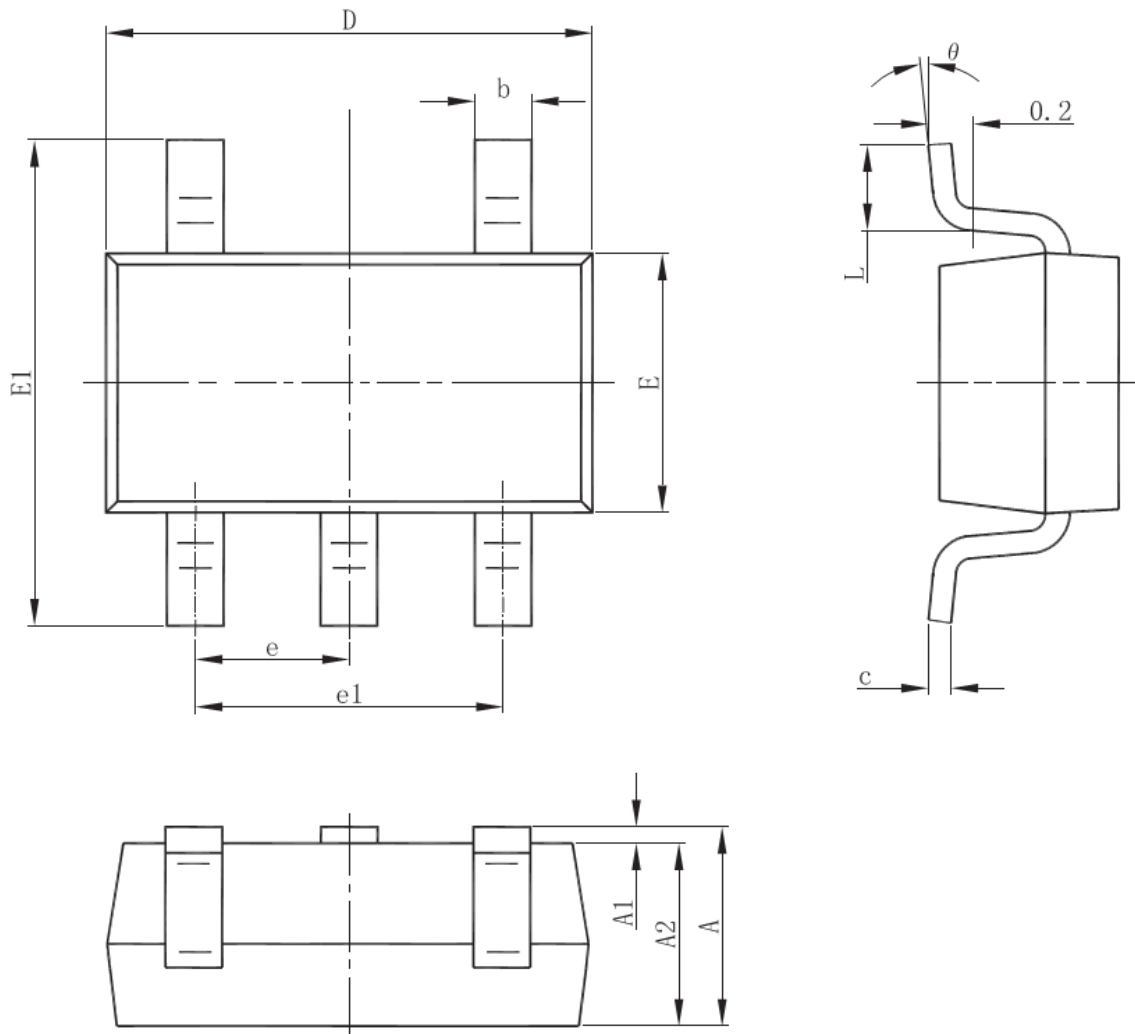
Package outline dimensions
SOT-23-5L

Symbol	Dimensions In Millimeters	
	Min.	Max.
A	1.050	1.250
A1	0.000	0.100
A2	1.050	1.150
b	0.300	0.500
c	0.100	0.200
D	2.820	3.020
E	1.500	1.700
E1	2.650	2.950
e	0.950(Basic)	
e1	1.800	2.000
L	0.300	0.600
theta	0°	8°