

## DESCRIPTION

The WS5203 is a monolithic synchronous buck regulator. The device integrates 100mΩ MOSFETS that provide 3A continuous load current over a wide operating input voltage of 4.75V to 30V. Current mode control provides fast transient response and cycle-by-cycle current limit.

An adjustable soft-start prevents inrush current at turn-on. In shutdown mode, the supply current drops below 1 μA.

This device, available in an 8-pin ESOP package, provides a very compact system solution with minimal reliance on external components.

## FEATURES

- 3A Output Current
- Wide 4.75V to 30V Operating Input Range
- Integrated 100mΩ Power MOSFET Switches
- Output Adjustable from 0.925V to 20V
- Up to 95% Efficiency
- Programmable Soft-Start
- Stable with Low ESR Ceramic Output Capacitors
- Fixed 300KHz Frequency
- Cycle-by-Cycle Over Current Protection
- Input Under Voltage Lockout
- Thermally Enhanced 8-Pin SOIC Package

## APPLICATIONS

- Distributed Power Systems
- Networking Systems
- Set-top Box
- LCD TV/Monitor
- Notebook or Mini-Book

## PACKAGE REFERENCE

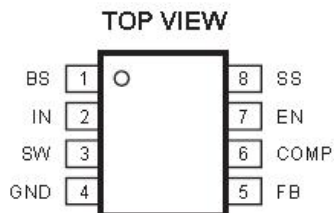

Part number	Package	Temperature
WS5203	SOP8	-20° C to +85° C

## ABSOLUTE MAXIMUM RATINGS<sup>(1)</sup>

Supply Voltage ( $V_{IN}$ )	-0.3V to 30V
Switch Voltage ( $V_{SW}$ )	-1V to $V_{IN} + 0.3V$
Bootstrap Voltage ( $V_{BS}$ )	$V_{SW} - 0.3V$ to $V_{SW} + 6V$
Enable/UVLO Voltage ( $V_{EN}$ )	-0.3V to +6V
Comp Voltage ( $V_{COMP}$ )	-0.3V to +6V
Feedback Voltage ( $V_{FB}$ )	-0.3V to +6V
Junction Temperature	+150°C
Lead Temperature	+260°C
Storage Temperature	-55°C to +150°C

## Recommended Operating Conditions<sup>(2)</sup>

Input Voltage ( $V_{IN}$ )	4.75V to 30V
Output Voltage ( $V_{SW}$ )	0.925 to 20V
Operating Temperature	-20°C to +85°C

## Thermal Resistance<sup>(3)</sup> $\theta_{JA}$ $\theta_{JC}$

SOIC8N	50	10	°C/W
--------	----	----	------

### Notes:

- 1) Exceeding these ratings may damage the device.
- 2) The device is not guaranteed to function outside of its operating conditions.
- 3) Measured on approximately 1" square of 1 oz copper.

## ELECTRICAL CHARACTERISTICS

$V_{IN} = 12V$ ,  $T_A = +25C$ , unless otherwise noted.

Parameter	Condition	Min	Typ	Max	Units
Shutdown Supply Current	$V_{EN} \leq 0.3V$		0.3	3.0	$\mu A$
Supply Current	$V_{EN} \geq 2.6V$ , $V_{FB} = 1.0V$		1.3	1.5	mA
Feedback Voltage	$4.75V \leq V_{IN} \leq 30V$	0.900	0.925	0.950	V
Feedback Overvoltage Threshold			1.1		V
Error Amplifier Voltage			480		V/V
Error Amplifier Transconductance	$\Delta I_c = \pm 10\mu A$		800		$\mu A/V$
High-Side Switch-On Resistance			100		m $\Omega$
Low-Side Switch-On Resistance			100		m $\Omega$
High-Side Switch Leakage	$V_{EN} = 0V$ , $V_{SW} = 0V$		1	10	$\mu A$
Upper Switch Current Limit			2.0	2.5	A
Lower Switch Current Limit			0.9		A
COMP to Current Sense Transconductance			4.0		A/V
Oscillator Frequency		350	400	450	KHz
Short Circuit Frequency	$V_{FB} = 0V$		150		KHz
Maximum Duty Cycle	$V_{FB} = 0.8V$		90		%
Minimum On Time			120		nS
EN Shutdown Threshold Voltage	$V_{EN}$ Rising	1.1	1.5	2.0	V
EN Shutdown Threshold Voltage Hysteresis			200		mV
EN Lockout Threshold Voltage		2.2	2.5	2.7	V
EN Lockout Hysteresis			210		mV
Input UVLO Threshold Rising	$V_{IN}$ Rising	3.80	4.20	4.40	V
Input UVLO Threshold Hysteresis			210		mV
Soft-start Current	$V_{SS} = 0V$		6.5		$\mu A$
Soft-start Period	$C_{SS} = 0.1\mu F$		15		ms
Thermal Shutdown <sup>4</sup>			160		$^{\circ}C$

**Note:**

4) Guaranteed by design

## APPLICATION

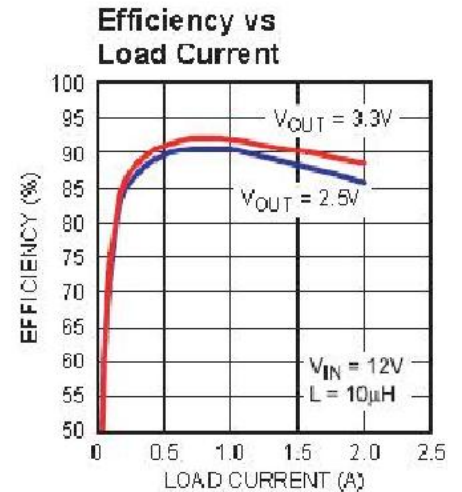
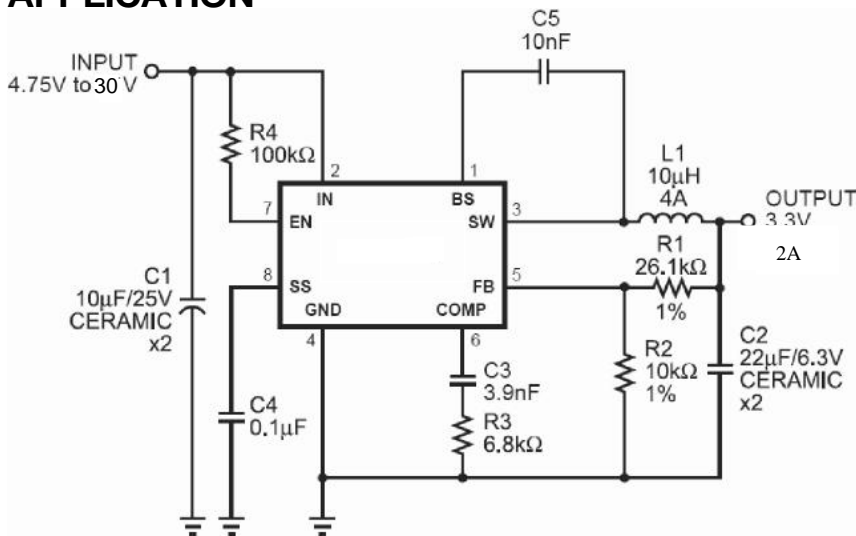

## PIN FUNCTIONS

Pin #	Name	Description
1	BS	High-Side Gate Drive Boost Input. BS supplies the drive for the high-side N-Channel MOSFET switch. Connect a 0.01 $\mu$ F or greater capacitor from SW to BS to power the high side switch.
2	IN	Power Input. IN supplies the power to the IC, as well as the step-down converter switches. Drive IN with a 4.75V to 30V power source. Bypass IN to GND with a suitably large capacitor to eliminate noise on the input to the IC. See <b>Input Capacitor</b> .
3	SW	Power Switching Output. SW is the switching node that supplies power to the output. Connect the output LC filter from SW to the output load. Note that a capacitor is required from SW to BS to power the high-side switch.
4	GND	Ground.
5	FB	Feedback Input. FB senses the output voltage to regulate that voltage. Drive FB with a resistive voltage divider from the output voltage. The feedback threshold is 0.925V. See <b>Setting the Output Voltage</b> .
6	COMP	Compensation Node. COMP is used to compensate the regulation control loop. Connect a series RC network from COMP to GND to compensate the regulation control loop. In some cases, an additional capacitor from COMP to GND is required. See <b>Compensation Components</b> .
7	EN	Enable Input. EN is a digital input that turns the regulator on or off. Drive EN high to turn on the regulator, drive it low to turn it off. Pull up with 100k $\Omega$ resistor for automatic
8	SS	Soft-Start Control Input. SS controls the soft-start period. Connect a capacitor from SS to GND to set the soft-start period. A 0.1 $\mu$ F capacitor sets the soft-start period to 15ms. To disable the soft-start feature, leave SS unconnected.

**OPERATION**

**FUNCTIONAL DESCRIPTION**

The WS5203 is a synchronous rectified, current-mode, step-down regulator. It regulates input voltages from 4.75V to 30V down to an output voltage as low as 0.925V, and supplies up to 3A of load current.

The WS5203 uses current-mode control to regulate the output voltage. The output voltage is measured at FB through a resistive voltage divider and amplified through the internal trans-conductance error amplifier. The voltage at the COMP pin is compared to the switch current measured internally to control the output voltage.

The converter uses internal N-Channel MOSFET switches to step-down the input voltage to the regulated output voltage. Since the high side MOSFET requires a gate voltage greater than the input voltage, a boost capacitor connected between SW and BS is needed to drive the high side gate. The boost capacitor is charged from the internal 5V rail when SW is low.

When the WS5203 FB pin exceeds 20% of the nominal regulation voltage of 0.925V, the over voltage comparator is tripped and the COMP pin and the SS pin are discharged to GND, forcing the high-side switch off.

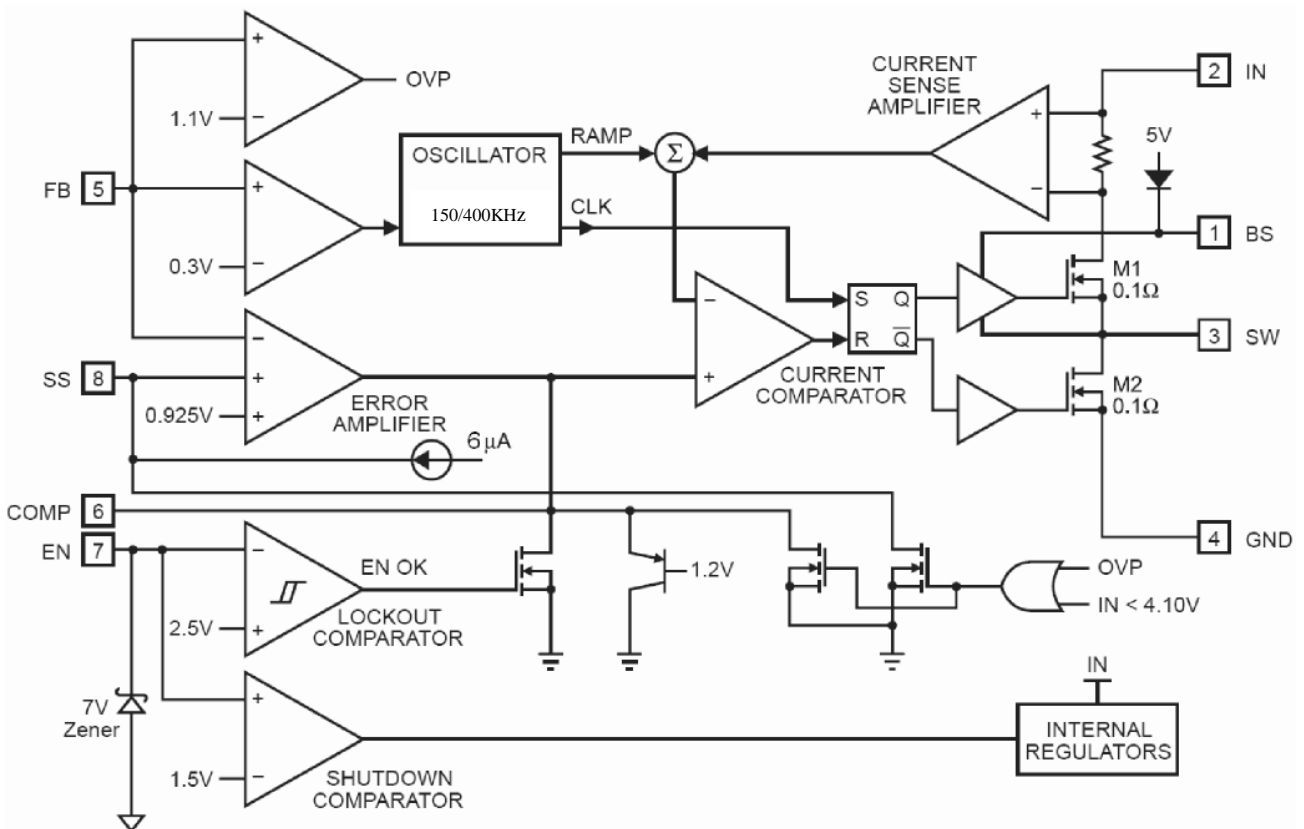

Figure 1 – Functional Block Diagram

**APPLICATION INFORMATION  
COMPONENT SELECTION**

**Setting the Output Voltage**

The output voltage is set using a resistive voltage divider from the output voltage to FB (see Typical Application circuit on page 1). The voltage divider divides the output voltage down by the ratio:

$$V_{FB} = V_{OUT} \frac{R2}{R1 + R2}$$

Where  $V_{FB}$  is the feedback voltage and  $V_{OUT}$  is the output voltage.

Thus the output voltage is:

$$V_{OUT} = 0.925 \times \frac{R1 + R2}{R2}$$

R2 can be as high as 100kΩ, but a typical value is 10kΩ. Using the typical value for R2, R1 is determined by:

$$R1 = 10.81 \times (V_{OUT} - 0.925) \text{ (k}\Omega\text{)}$$

For example, for a 3.3V output voltage, R2 is 10kΩ, and R1 is 26.1kΩ. Table 1 lists recommended resistance values of R1 and R2 for standard output voltages.

**Table 1—Recommended Resistance Values**

VOUT	R1	R2
1.8V	9.53kΩ	10kΩ
2.5V	16.9kΩ	10kΩ
3.3V	26.1kΩ	10kΩ
5V	44.2kΩ	10kΩ
12V	121kΩ	10kΩ

**Inductor**

The inductor is required to supply constant current to the output load while being driven by the switched input voltage. A larger value inductor will result in less ripple current that will result in lower output ripple voltage. However, the larger value inductor will have a larger physical size, higher series resistance, and/or lower saturation current. A good rule for determining the inductance to use is to allow the peak-to-peak ripple current in the inductor to be approximately 30% of the maximum switch current limit. Also, make sure that the peak inductor current is below the maximum switch current limit. The inductance value can be calculated by:

$$L = \frac{V_{OUT}}{f_s \times \Delta I_L} \times \left(1 - \frac{V_{OUT}}{V_{IN}}\right)$$

Where  $V_{OUT}$  is the output voltage,  $V_{IN}$  is the input voltage,  $f_s$  is the switching frequency, and  $\Delta I_L$  is the peak-to-peak inductor ripple current.

Choose an inductor that will not saturate under the maximum inductor peak current. The peak inductor current can be calculated by:

$$I_{LP} = I_{LOAD} + \frac{V_{OUT}}{2 \times f_s \times L} \times \left(1 - \frac{V_{OUT}}{V_{IN}}\right)$$

Where  $I_{LOAD}$  is the load current.

The choice of which style inductor to use mainly depends on the price vs. size requirements and any EMI requirements.

**Optional Schottky Diode**

During the transition between high-side switch and low-side switch, the body diode of the lowside power MOSFET conducts the inductor current. The forward voltage of this body diode is high. An optional Schottky diode may be paralleled between the SW pin and GND pin to improve overall efficiency. Table 2 lists example Schottky diodes and their Manufacturers.

**Table 2—Diode Selection Guide**

Part Number	Voltage/Current Rating	Vendor
B130	30V, 1A	Diodes, Inc.
SK13	30V, 1A	Diodes, Inc.
MBRS130	30V, 1A	International Rectifier

**Input Capacitor**

The input current to the step-down converter is discontinuous, therefore a capacitor is required to supply the AC current to the step-down converter while maintaining the DC input voltage. Use low ESR capacitors for the best performance. Ceramic capacitors are preferred, but tantalum or low-ESR electrolytic capacitors may also suffice. Choose X5R or X7R dielectrics when using ceramic capacitors. Since the input capacitor absorbs the input switching current it requires an adequate ripple current rating. The RMS current in the input capacitor can be estimated by:

$I_{CIN} = I_{LOAD} \times \sqrt{\frac{V_{OUT}}{V_{IN}} \times \left(1 - \frac{V_{OUT}}{V_{IN}}\right)}$  The worst-case condition occurs at  $V_{IN} = 2V_{OUT}$ , where  $I_{CIN} = I_{LOAD}/2$ . For simplification, choose the input capacitor whose RMS current rating greater than half of the maximum load current. The input capacitor can be electrolytic, tantalum or ceramic. When using electrolytic or tantalum capacitors, a small, high quality ceramic capacitor, i.e. 0.1 $\mu$ F, should be placed as close to the IC as possible. When using ceramic capacitors, make sure that they have enough capacitance to provide sufficient charge to prevent excessive voltage ripple at input. The input voltage ripple for low ESR capacitors can be estimated by:

$$\Delta V_{IN} = \frac{I_{LOAD}}{C_{IN} \times f_s} \times \frac{V_{OUT}}{V_{IN}} \times \left(1 - \frac{V_{OUT}}{V_{IN}}\right)$$

Where  $C_{IN}$  is the input capacitance value.

### Output Capacitor

The output capacitor is required to maintain the DC output voltage. Ceramic, tantalum, or low ESR electrolytic capacitors are recommended. Low ESR capacitors are preferred to keep the output voltage ripple low. The output voltage ripple can be estimated by:

$$\Delta V_{OUT} = \frac{V_{OUT}}{f_s \times L} \times \left(1 - \frac{V_{OUT}}{V_{IN}}\right) \times \left(R_{ESR} + \frac{1}{8 \times f_s \times C_O}\right)$$

Where  $C_O$  is the output capacitance value and  $R_{ESR}$  is the equivalent series resistance (ESR) value of the output capacitor. In the case of ceramic capacitors, the impedance at the switching frequency is dominated by the capacitance. The output voltage ripple is mainly caused by the capacitance. For simplification, the output voltage ripple can be estimated by:

$$\Delta V_{OUT} = \frac{V_{OUT}}{8 \times f_s^2 \times L \times C_O} \times \left(1 - \frac{V_{OUT}}{V_{IN}}\right)$$

In the case of tantalum or electrolytic capacitors, the ESR dominates the impedance at the switching frequency. For simplification, the output ripple can be approximated to:

$$\Delta V_{OUT} = \frac{V_{OUT}}{f_s \times L} \times \left(1 - \frac{V_{OUT}}{V_{IN}}\right) \times R_{ESR}$$

The characteristics of the output capacitor also affect the stability of the regulation system. The WS5203 optimized for a wide range of capacitance and ESR values.

### Compensation Components

WS5203 employs current mode control for easy compensation and fast transient response. The system stability and transient response are controlled through the COMP pin. COMP pin is the output of the internal transconductance error amplifier. A series capacitor-resistor combination sets a pole-zero combination to control the characteristics of the control system.

The DC gain of the voltage feedback loop is given by:

$$A_{VDC} = R_{LOAD} \times G_{CS} \times A_{EA} \times \frac{V_{FB}}{V_{OUT}}$$

Where  $V_{FB}$  is the feedback voltage, 0.925V;

$A_{VEA}$  is the error amplifier voltage gain;  $G_{CS}$  is the current sense transconductance and  $R_{LOAD}$  is the load resistor value.

The system has two poles of importance. One is due to the compensation capacitor ( $C_3$ ) and the output resistor of the error amplifier, and the other is due to the output capacitor and the load resistor. These poles are located at:

$$f_{P1} = \frac{G_{EA}}{2\pi \times C_3 \times A_{VEA}}$$

$$f_{P2} = \frac{1}{2\pi \times C_O \times R_{LOAD}}$$

Where  $G_{EA}$  is the error amplifier transconductance.

The system has one zero of importance, due to the compensation capacitor ( $C_3$ ) and the compensation resistor ( $R_3$ ). This zero is located at:

$$f_{Z1} = \frac{1}{2\pi \times C_3 \times R_3}$$

The system may have another zero of importance, if the output capacitor has a large capacitance and/or a high ESR value. The zero, due to the ESR and capacitance of the output capacitor, is located at:

$$f_{Z1} = \frac{1}{2\pi \times C_3 \times R_3}$$

In this case (as shown in Figure 2), a third pole set by the compensation capacitor ( $C_6$ ) and the compensation resistor ( $R_3$ ) is used to compensate the effect of the ESR zero on the loop gain. This pole is located at:

$$f_{ESR} = \frac{1}{2\pi \times C_O \times R_{ESR}}$$

The goal of compensation design is to shape the converter transfer function to get a desired loop gain. The system crossover frequency where the feedback loop has the unity gain is important. Lower crossover frequencies result in slower line and load transient responses, while higher crossover frequencies could cause system instability. A good rule of thumb is to set the crossover frequency below one-tenth of the switching frequency.

To optimize the compensation components, the following procedure can be used.

1. Choose the compensation resistor (R3) to set the desired crossover frequency. Determine the R3 value by the following equation:

$$R3 = \frac{2\pi \times C_O \times f_c}{G_{EA} \times G_{CS}} \times \frac{V_{OUT}}{V_{FB}} < \frac{2\pi \times C_O \times 0.1 \times f_s}{G_{EA} \times G_{CS}} \times \frac{V_{OUT}}{V_{FB}}$$

Where  $f_c$  is the desired crossover frequency which is typically below one tenth of the switching frequency.

2. Choose the compensation capacitor (C3) to achieve the desired phase margin. For applications with typical inductor values, setting the compensation zero,  $f_{z1}$ , below one-fourth of the crossover frequency provides sufficient phase margin.

Determine the C3 value by the following equation:

$$C3 > \frac{4}{2\pi \times R3 \times f_c}$$

Where R3 is the compensation resistor.

3. Determine if the second compensation

capacitor (C6) is required. It is required if the ESR zero of the output capacitor is located at less than half of the switching frequency, or the following relationship is valid:

$$\frac{1}{2\pi \times C_O \times R_{ESR}} < \frac{f_s}{2}$$

If this is the case, then add the second compensation capacitor (C6) to set the pole  $f_{p3}$  at the location of the ESR zero. Determine the C6 value by the equation:

$$C6 = \frac{C_O \times R_{ESR}}{R3}$$

### External Bootstrap Diode

It is recommended that an external bootstrap diode be added when the system has a 5V fixed input or the power supply generates a 5V output. This helps improve the efficiency of the regulator. The bootstrap diode can be a low cost one such as IN4148 or BAT54.

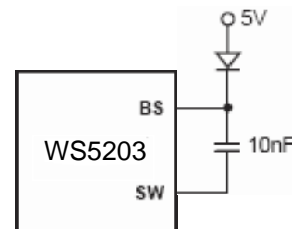

**Figure 2—External Bootstrap Diode**

This diode is also recommended for high duty cycle operation when output voltage ( $V_{OUT} > 12V$ ) applications

**TYPICAL APPLICATION CIRCUITS**

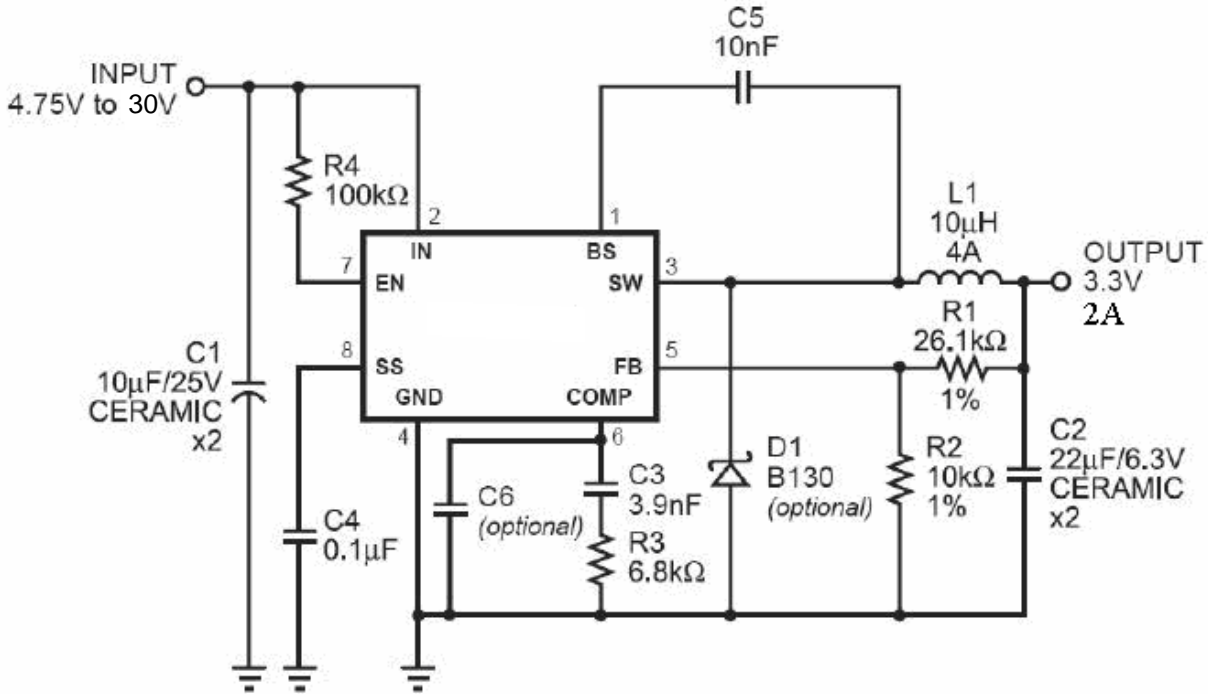

**Figure 3— WS5203 with AVX 47µF, 6.3V Ceramic Output Capacitor**

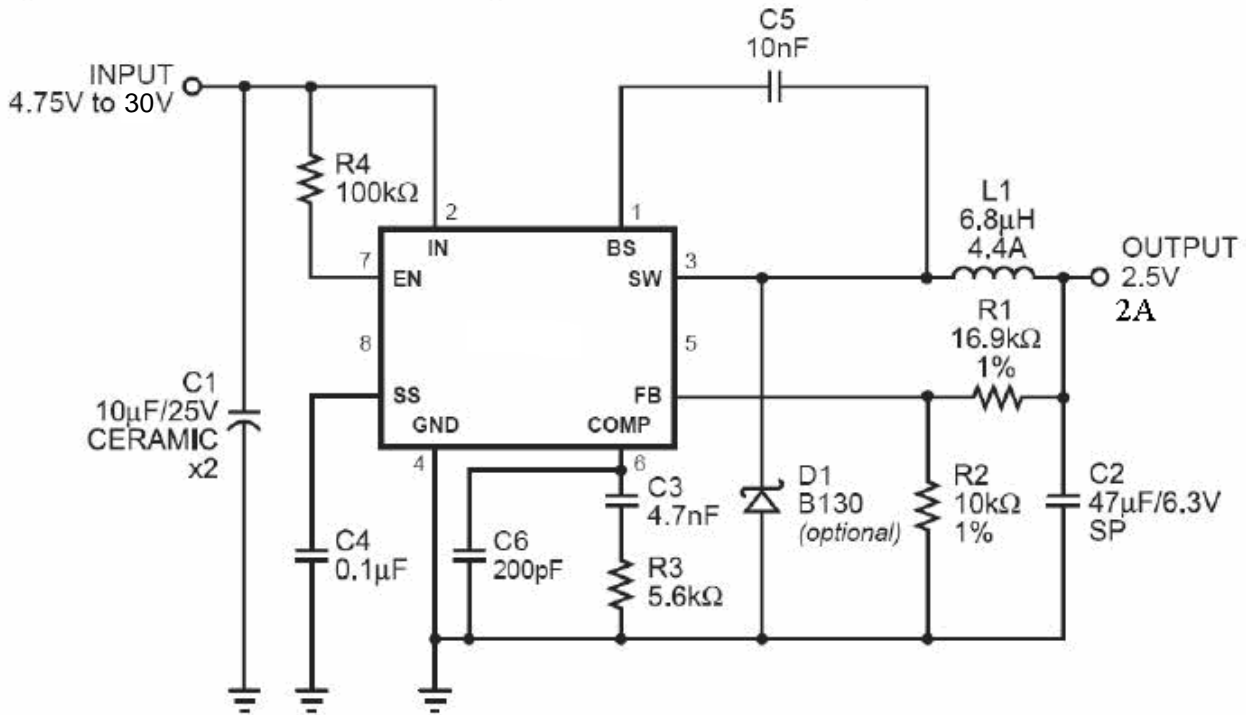

**Figure 4— WS5203 with Panasonic 47µF, 6.3V Solid Polymer Output Capacitor**



**PACKAGE INFORMATION**

**PACKAGE INFORMATION**

**ESOP8**

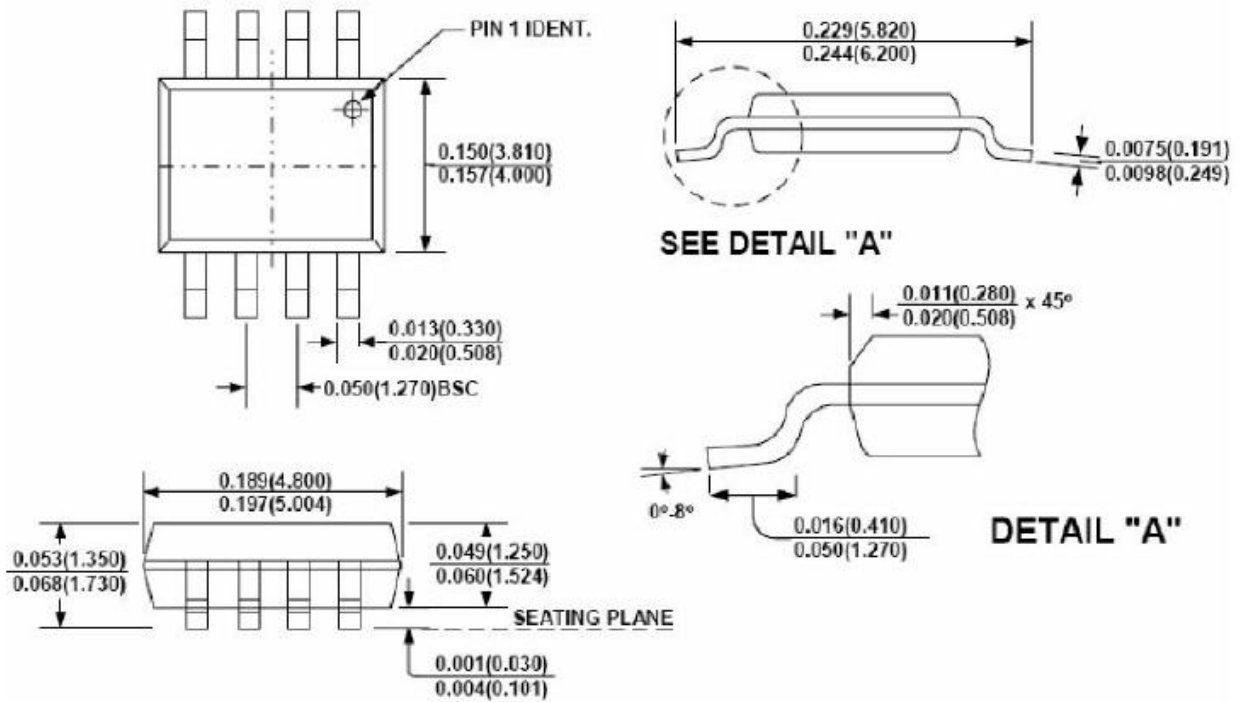

**NOTE:**  
1) Control dimension is in inches. Dimension in bracket is millimeters.