

High Precision PSR Constant Current LED Driver

Features

- Constant current control without secondary sense and feedback circuit.
- $\pm 3\%$ LED current accuracy
- Ultra low operating current to improve efficiency
- High resistance feedback resistor to improve efficiency
- Universal input voltage
- LED short and open circuit protection
- VCC under-voltage protection
- Feedback loop short circuit protection
- Current sense resistor open circuit protection
- Over temperature protection
- No external loop compensation component required
- Available in SOT23-5 package

Applications

- GU10/E27 LED bulb, spot light
- Other LED lighting

Description

The WS9252 is a high precision primary-side feedback and regulation controller for LED lighting, it operates in constant current control mode and is designed to work in inductor current discontinuous conduction mode and extremely suitable for buckboost/flyback convertor under universal input.

Since adopting primary sense and feedback control technology, the secondary sense and feedback circuit is eliminated. The loop compensation components are also removed while maintaining stability overall operating conditions. The low component counts and low BOM cost are realized.

Since using the proprietary high accurate current sense method, the WS9252 realizes $\pm 3\%$ accuracy of LED current along with excellent line regulation and load regulation.

The WS9252 offers rich protection functions including LED short circuit protection, LED open circuit protection, die over-temperature protection, VCC over voltage protection, VCC under voltage protection and FB short circuit protection. All the protection features are auto-recovery.

Typical Application

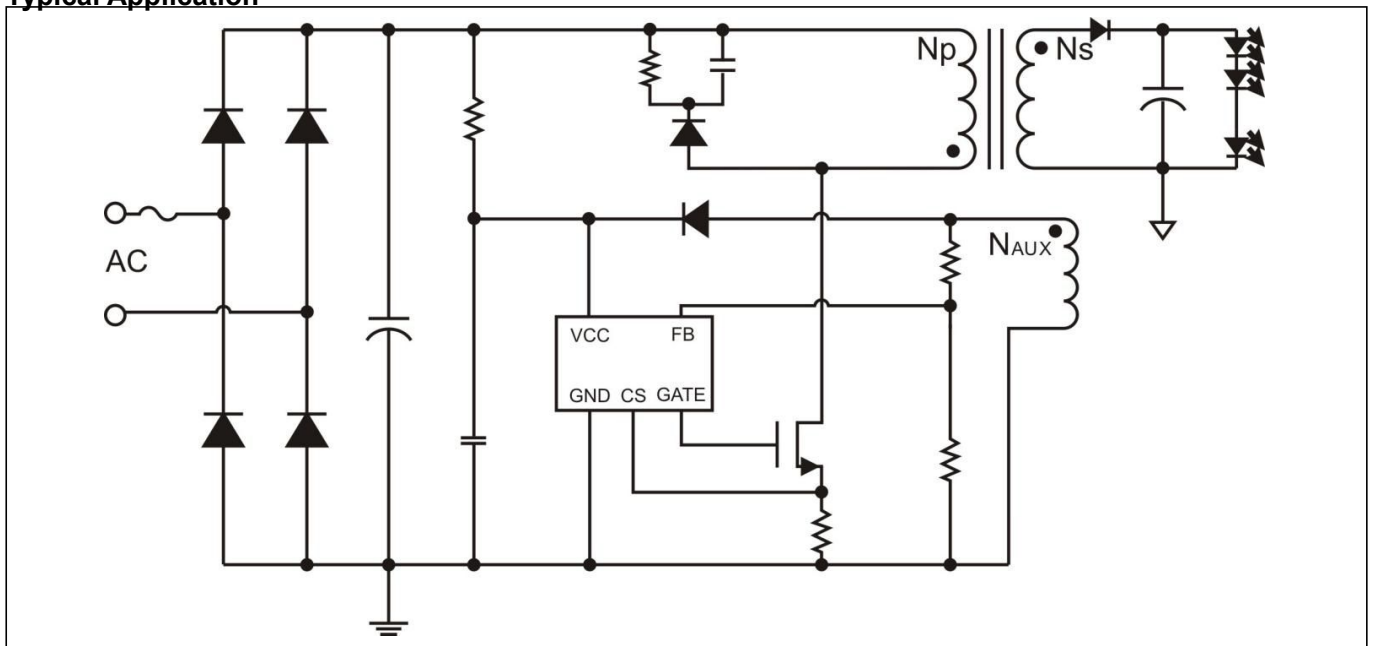

Pin Configuration and Marking Information

WS9252 is offered in SOT23-5 package, as bellows:

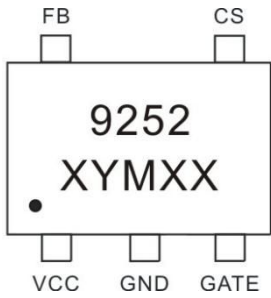

9252: Product Code
 X: Product Code
 YM: Production Date
 XX: Internal Code For QC

Pin Definition

Pin No.	Pin Name	Function Description
1	VCC	Power supply
2	GND	Ground
3	GATE	Gate Driver Pin. Connect it to the gate of external power MOSFET.
4	CS	Current sense. This pin connects a current sense resistor to GND to detect the primary current of transformer.
5	FB	Feedback Pin. This pin detects the output information from auxilliary winding.

Internal Block Diagram

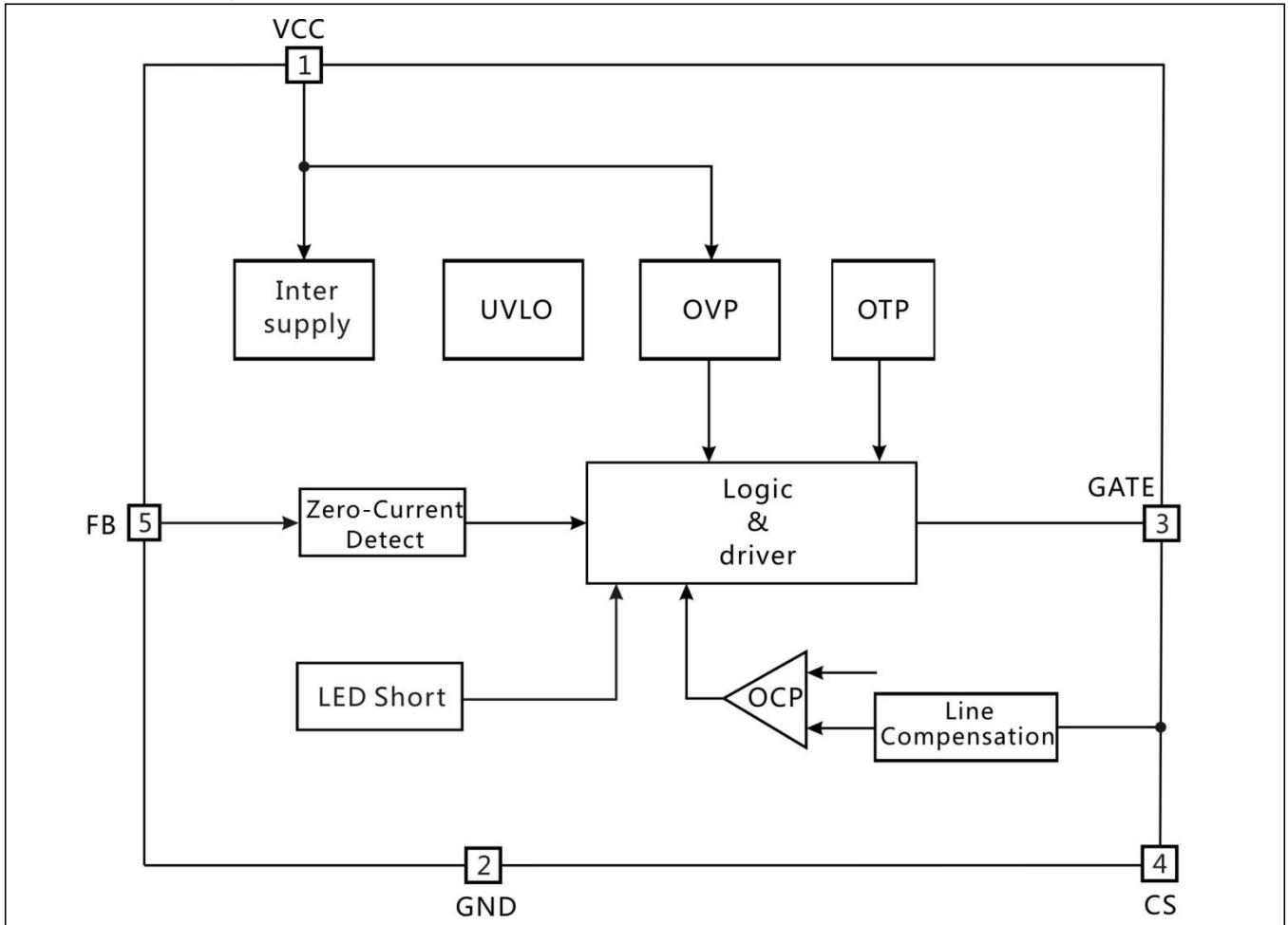

Ordering Information

Package	Marking	Part Number
5-Pin SOT23-5, Pb-free	WS9252YP	WS9252YP

Recommended Operation Conditions

Symbol	Parameter	Value	Unit
TA	Operation temperature	-20~85	°C
Fmax	Maximum working frequency	100	khz
VCC	Power supply voltage	10~17.5	V
POUT1	Output power(Input voltage230V±15%)	<50	W
POUT2	Output power(Input voltage85V~265V)	<36	W

Absolute Maximum Ratings (Note1)

symbol	paramete	limites	unit
VCC	VCC pin input voltage	-0.3~20	V
FB	Feedback pin input voltage	-0.3~6	V
Gate	Gate driver of external power MOSFET	-0.3~20	V
CS	Current sense pin input voltage	-0.3~6	V
PDMAX	Power dissipation (note2)	0.3	W
Tjo	Operating junction temperature	-40~150	°C
θJA	Thermal resistance (Junction to Ambient)	300	°C/W
TSTG	Storage temperature range	-55~150	°C

Note 1: Stresses beyond those listed under “absolute maximum ratings” may cause permanent damage to the device. Under “recommended operating conditions” the device operation is assured, but some particular parameter may not be achieved. The electrical characteristics table defines the operation range of the device, the electrical characteristics is assured on DC and AC voltage by test program. For the parameters without minimum and maximum value in the EC table, the typical value defines the operation range, the accuracy is not guaranteed by spec.

Note 2: The maximum power dissipation decrease if temperature rise, it is decided by TJMAX, θJA, and environment temperature (TA). The maximum power dissipation is the lower one between PDMAX = (TJMAX - TA)/ θJA and the number listed in the maximum table.

Electrical Characteristics (Unless otherwise specified, VCC=8V and TA =25 °C)

Symbol	Parameter	Test condition	Min	Typ	Max	Units
Supply Voltage Section						
VDD_CLAMP	VDD Clamping Voltage	4mA	17.4	18.3	19.4	V
UVLO_on	VDD Power Supply		16.1	17.1	18.1	V
UVLO_off	VDD Under Voltage Lockout		8.5	9	9.5	V
VCC_OVP	VCCover voltage protection level		17.9	18.9	19.9	V
Ist	Start up current			35		uA
Iop	Operating current			152		uA
Current Sense Section						
Ipp	Primary Peak Current		484	508	531	mV
TLEB	Lead Edge Blanking			500		ns
TDELAY	Shutdown Delay			200		ns
D_max	Maximum Duty Cycle			42		%
FeedbackInputSection						
Toff_max	MaximumDemagnetization time			420		us
Toff_min	MinimumDemagnetization time			4		us
Ton_max	MaxmiumON time			100		us
Vfb	FB voltage sense level			1		V
Power MOSFET						
Isource	GATE Pin Sourcing Current			100		mA
Rds_off	Resistor Of Gate Driver(OFF)			20		Ω
Over TemperatureProtection						
T_comp	Thermal Regulation Temperature			147		°C

Application Information

The WS9252 is a high performance power switch specially designed for LED lighting, it uses the patent constant current control technology of WINSEMI. The accurate LED current can be realized without opto-coupler and TL431 feedback circuit while minimizing the external component count, lowering the total bill of material cost.

Start Up

The VCC capacitor will be charged through the start-up resistor when the system is powered on, once the voltage on VCC reaches the start-up threshold, the WS9252 will start to operate, and then the VCC is supplied by the auxiliary winding.

Constant Current Control

Cycle-by-Cycle current sense is offered in WS9252, the CS is connected to the current sense comparator, and the voltage on CS will be compared with the internal 508mV reference voltage, the MOSFET will be switched off when the voltage on CS reaches the threshold. The output of the comparator also includes a 500nS leading edge blanking time

The primary peak current is given by:

$$I_{P_PK} = \frac{508}{R_{CS}} (mA)$$

The current in LED can be calculated by the equation:

$$I_{OUT} = \frac{I_{P_PK}}{4} \times \frac{N_P}{N_S}$$

Where,

NP: primary winding turns of transformer

NS: secondary winding turns of transformer

IP_PK: peak current in MOSFET

Feedback Network

The WS9252 senses the output information through the feedback network and the FB threshold voltage is set to 1V. The ratio of FB upper resistor to lower resistor is

recommended to about 4.0. The FB upper resistor can be set to 300KΩ~750KΩ to improve efficiency of convertor.

Operation Switching Frequency

The WS9252 is designed to work in discontinuous conduction mode and no external loop compensation component is required while maintaining stability. The maximum duty cycle is limited to 42%. The maximum switching frequency should be set to less than 100KHz and the minimum switching frequency should be set to more than 20KHz. The maximum and minimum switching frequency is limited in WS9252 to ensure the stability of system.

The switching frequency can be set by the formula:

$$f = \frac{N_P^2 \times V_{LED}}{8 \times N_S^2 \times L_P \times I_{LED}}$$

Where, LP is the primary winding inductance of transformer.

Protection Function

The WS9252 has several protection functions. The internal MOSFET will be shut down immediately when the voltage on VCC reaches the threshold of OVP and the device will not recover until the protection condition is removed. A 18V zener diode is designed in the WS9252 to prevent the chip damage from the abnormal situation.

The thermal protection circuitry in the WS9252 senses the die temperature after start up, and the thermal protection threshold is set to 147°C

The system will work in low consumption mode when the output LED short circuit or open circuit is detected. While the WS9252 continuous to detect output status until the LED recover to normal condition, and then the device will be operate in normal mode.

PCB Layout

The following rules should be followed in WS9252 PCB layout:

Bypass Capacitor

The bypass capacitor on VCC should be as close as possible to the VCC pin

Ground Path

The power ground path for current sense should be short, and the power ground path should be separated from small signal ground path before the negative of the bulk capacitor.

The Area of Power Loop

The area of main current loop should be as small as possible to reduce EMI radiation, such as the primary current loop, the snubber circuit and the secondary rectifying loop.

FB Pin

The feedback divider should be as close as possible to FB Pin and the node must keep away from dynamic node of transformer.

Package Information

SOT23-5 Package Outline Dimensions

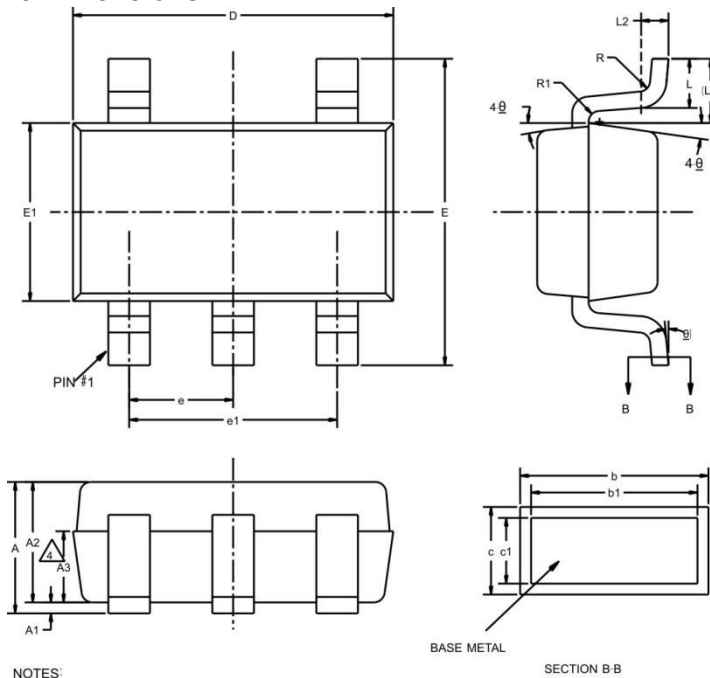

NOTES:
 ALL DIMENSIONS REFER TO JEDEC STANDARD MO-178 C
 DO NOT INCLUDE MOLD FLASH OR PROTRUSIONS

Symbol	Winsemi	
	Dimensions in Millimeters	
	Min	Max
A	-	1.45
A1	0	0.15
A2	0.90	1.30
A3	0.60	0.70
b	0.39	0.49
b1	0.35	0.45
c	0.08	0.22
c1	0.08	0.20
D	2.80	3.00
E	2.60	3.00
E1	1.50	1.70
e	0.85	1.05
e1	1.80	2.00
L	0.35	0.60
L1	0.60REF	
L2	0.25BSC	
R	0.10	-
R1	0.10	0.25
θ	0°	8°
θ 1	7°	11°
θ 2	8°	12°

NOTE:

- 1.We strongly recommend customers check carefully on the trademark when buying our product, if there is any question, please don't be hesitate to contact us.
- 2.Please do not exceed the absolute maximum ratings of the device when circuit designing.
- 3.Winsemi Microelectronics Co., Ltd reserved the right to make changes in this specification sheet and is subject to change without prior notice.

CONTACT:

Winsemi Microelectronics Co., Ltd.

ADD:Futian District, ShenZhen Tian An Cyber Tech Plaza two East Wing 1002

Post Code : 518040

Tel : +86-755-8250 6288

FAX : +86-755-8250 6299

Web Site : www.winsemi.com