

### Surface Mount Schottky Barrier Diodes

**(Pb)** Lead(Pb)-Free

#### Feature:

- \*Extremely High Switching Speed.
- \*Low Forward Voltage and Low Reverse Current.
- \*High Reliability.
- \*Schottky Barrier Diodes Encapsulated in a SOD-523 Package

#### Description:

These schottky barrier diodes are designed for high speed switching applications circuit protection, and voltage clamping, Extremely low forward voltage reduces conduction loss, Miniature surface mount package is excellent for hand held and portable applications where space is limited.

**SMALL SIGNAL  
SCHOTTKY DIODES  
30m AMPERES  
40 VOLTS**

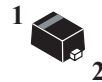

**SOD-523**

### SOD-523 Outline Dimensions

Unit:mm

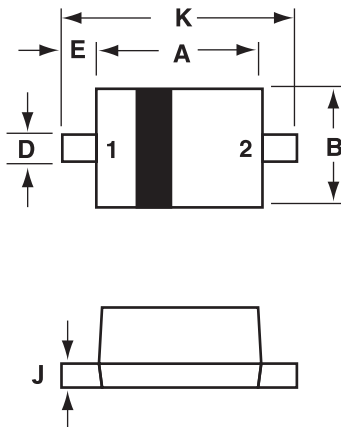

SOD-523		
Dim	Min	Max
A	1.10	1.30
B	0.70	0.90
C	0.50	0.70
D	0.25	0.35
E	0.15	0.25
J	0.07	0.20
K	1.50	1.70

PIN 1. CATHODE  
2. ANODE

## Maximum Ratings (T<sub>a</sub>=25 °C Unless otherwise noted)

Characteristic	Symbol	Value	Unit
Peak Reverse Voltage	V <sub>RM</sub>	40	Volts
DC Reverse Voltage	V <sub>R</sub>	30	Volts
Average Rectifier Forward Current	I <sub>F(AV)</sub>	30	mA
Peak Forward Surge Current <sup>(1)</sup>	I <sub>FSM</sub>	200	mA
Operating Junction Temperature Range	T <sub>J</sub>	-40 to +125	°C
Storage Temperature Range	T <sub>stg</sub>		

## Electrical Characteristics (T<sub>A</sub>=25 °C Unless otherwise noted)

Characteristic	Symbol	Min	TYP	Max	Unit
Reverse Breakdown Voltage (I <sub>R</sub> =100μA)	V(BR)R	30			Volts
Forward Voltage I <sub>F</sub> =1.0mA	V <sub>F</sub>			0.37	Volts
Reverse Leakage V <sub>R</sub> =30V	I <sub>R</sub>			0.5	μA <sub>dc</sub>
Capacitance Between Terminals V <sub>R</sub> =1V, f=MHZ	C <sub>T</sub>		2.0		PF

NOTE:

1.60HZ for 1 

## Device Marking

Item	Marking	Equivalent Circuit diagram
WSD751S	5	

## Electrical Characteristic Curves (Ta=25°C)

