

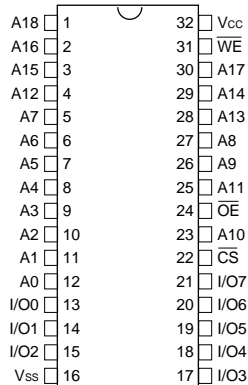

## 256Kx8 SRAM/ FLASH MODULE ADVANCED\*

FIG. 1

### PIN CONFIGURATION TOP VIEW



### PIN DESCRIPTION

A0-18	Address Inputs
I/O0-7	Data Input/Output
CS	Chip Select
OE	Output Enable
WE	Write Enable
Vcc	+5.0V Power
Vss	Ground

### BLOCK DIAGRAM

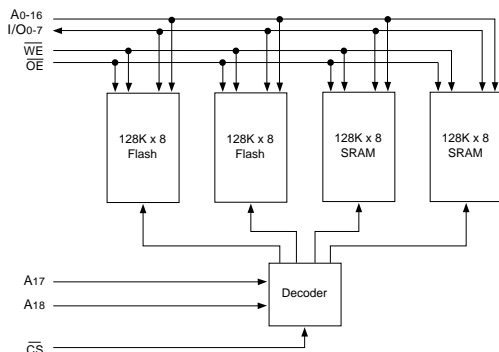

### FEATURES

- Access Times of 35ns (SRAM) and 70ns (FLASH)
- JEDEC Standard, Hermetic Ceramic Package, 32 pin DIP (Package 300)
- 256Kx8 SRAM
- 256Kx8 5V FLASH
- Memory Map
  - Flash Memory: 0H-3FFFFH
  - SRAM: 40000H-7FFFFH
- Low Power CMOS
- Commercial, Industrial and Military Temperature Ranges
- TTL Compatible Inputs and Outputs
- Built-in Decoupling Caps and Multiple Ground Pins for Low Noise Operation

### FLASH MEMORY FEATURES

- 10,000 Erase/Program Cycles
- Sector Architecture
  - 8 equal size sectors of 16KBytes each
  - Any combination of sectors can be concurrently erased. Also supports full chip erase
- Data Retention, 10 Years at 125°C
- 5 Volt Programming; 5V ± 10% Supply
- Embedded Erase and Program Algorithms
- Hardware and Software Write Protection
- Page Program Operation and Internal Program Control Time

\* This data sheet describes a product that may or may not be under development and is subject to change or cancellation without notice.



PACKAGE 300: 32 PIN, CERAMIC DIP, SINGLE CAVITY SIDE BRAZED

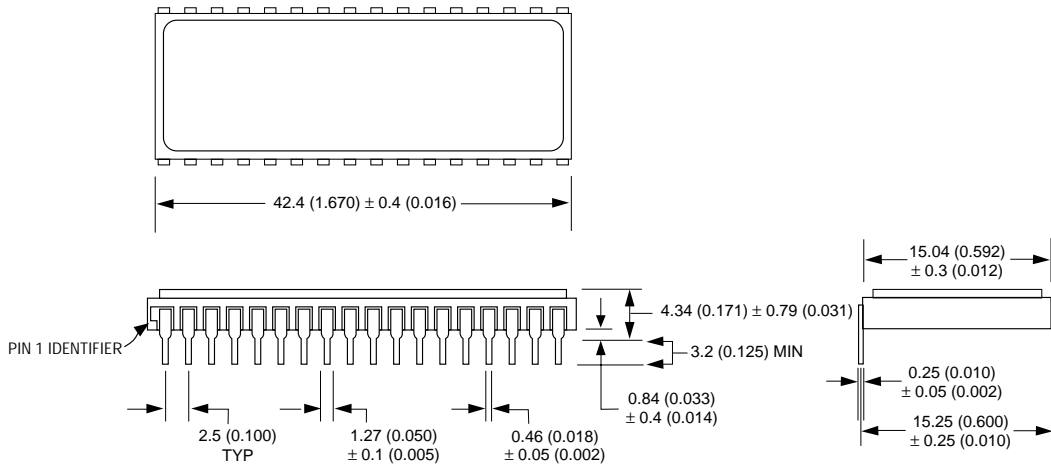

ALL LINEAR DIMENSIONS ARE MILLIMETERS AND PARENTHETICALLY IN INCHES

ORDERING INFORMATION

W S F 256K8 - XXX C X X

LEAD FINISH:

Blank = Gold plated leads

A = Solder dip leads

DEVICE GRADE:

M = Military Screened -55°C to +125°C

I = Industrial -40°C to +85°C

C = Commercial 0°C to +70°C

PACKAGE TYPE:

C = 32 DIP (Package 300)

ACCESS TIME (ns)

37 = 35ns SRAM and 70ns FLASH

72 = 70ns SRAM and 120ns FLASH also available

ORGANIZATION, 256K x 8

Flash PROM

SRAM

WHITE MICROELECTRONICS