

Linear Hall Effect Sensor IC

Features:

- Wide operating range 3.0~12V, -40°C~125°C
- Flat Response to 23kHz
- High Sensitivity 4.5mV/G
- Wide sensible magnetic field range on different supplied voltage
±450 Gauss on 5V supplied voltage
±1,000 Gauss on 12V supplied voltage. Low operating current 3mA
- Two package styles TO-92S/SOT-23 available.
- Built-in temperature compensated circuit to minimize temperature's effect

Functional Description :

The W137 integrates Hall sensing element, linear amplifier, sensitivity controller and emitter follower output stage. It accurately tracks extremely small change in magnetic flux density –generally too small to operate Hall effect switch.

W137 can be applied as current sensor, tooth sensor, proximity detectors and motion detectors. As sensitive monitor of magnetic flux, it can effectively measure a system's performance with negligible system loading while providing isolation from contaminated and electrically noisy environments.

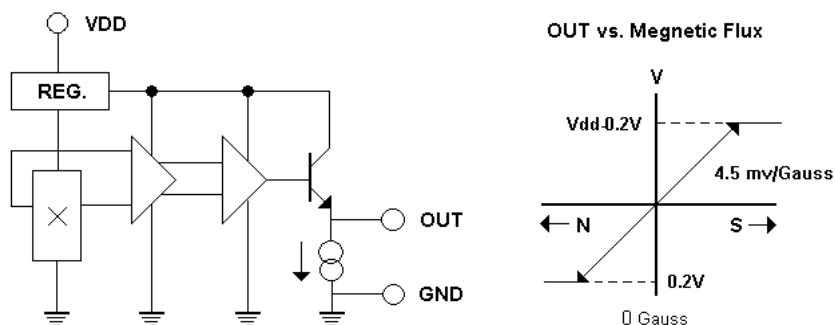

Winson reserves the right to make changes to improve reliability or manufacturability.

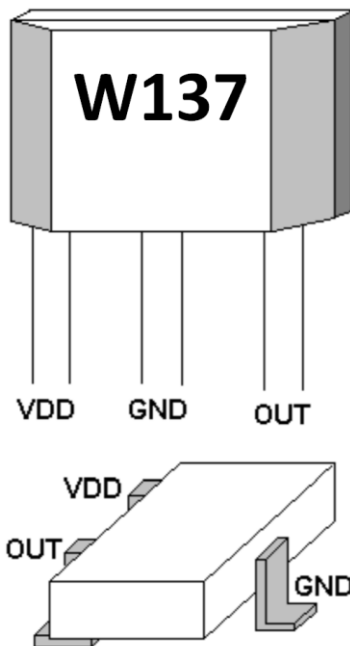

Absolute Maximum Range

Supply Voltage, Vdd	-----	14V
Magnetic Flux Density, B	-----	Unlimited
Output Driving Current, Iout	-----	0.4mA
Operating Temperature Range, Ta	-----	
	-----	-40°C to +125°C
Storage Temperature Range, Ts	-----	
	-----	-65°C to +150°C
Power Dissipation, Pd		
TO-92S	-----	500mW
SOT-23	-----	400mW

Order Information

WSH137-XPAN <input type="checkbox"/> (TO-92S)	1: A Grade
WSH137-XPCN <input type="checkbox"/> (SOT-23)	2: B Grade
 Grade	
Halogen Free	

★TO-92S – 1,000/bag , SOT-23 – 3,000/reel

Electrical Characteristics:

(T=+25°C, Vdd=5.0V)

Characteristic	Symbol	Test Conditions	Min	Typ	Max	Units
Supply Voltage	Vcc	—	3.0	—	12	V
Supply Current	Isupply	B=0 Gauss	—	3.0	5.0	mA
Quiescent Vout	V0G	B=0 G (A Grade)	2.45	2.5	2.55	V
		B=0 G (B Grade)	2.4	2.5	2.6	
Sensitivity	ΔV_{out}	B= 0 to \pm 400 G	4.0	4.5	5.0	mV/G
Bandwidth	BW	—	—	23	—	kHz
Measurable Gauss Range	MGR	Vdd=5V	—	\pm 450	—	Gauss
		Vdd=12V	—	\pm 1000	—	
Temperature Drift	ΔV_{out}	B=0 Gauss	—	\pm 0.5	—	mV/°C
Output Noise	V _{Np-p}	—	—	7.5	—	mV

1. All output-voltage measurements are made with a voltmeter having an input impedance of at least 100k Ω

2. Do not apply any 'resistor load' on output pin, it will degrade IC's performance.

Application circuit:

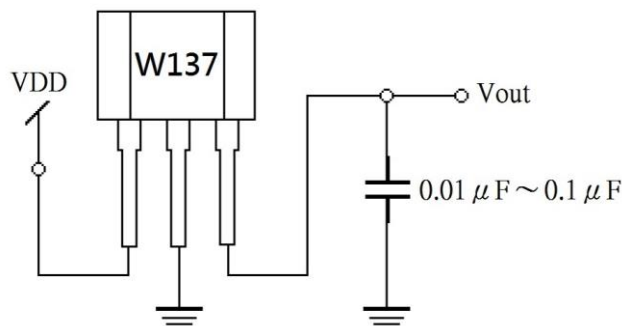

Winson reserves the right to make changes to improve reliability or manufacturability.

Hall Device Sensing Direction

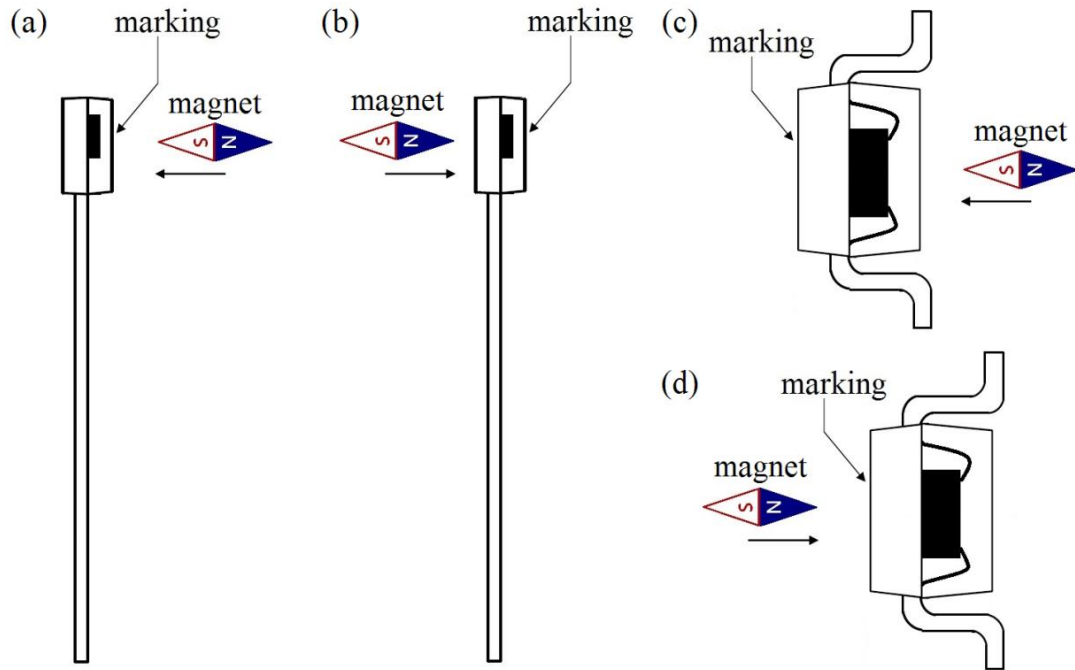

Package Information

《TO-92S》

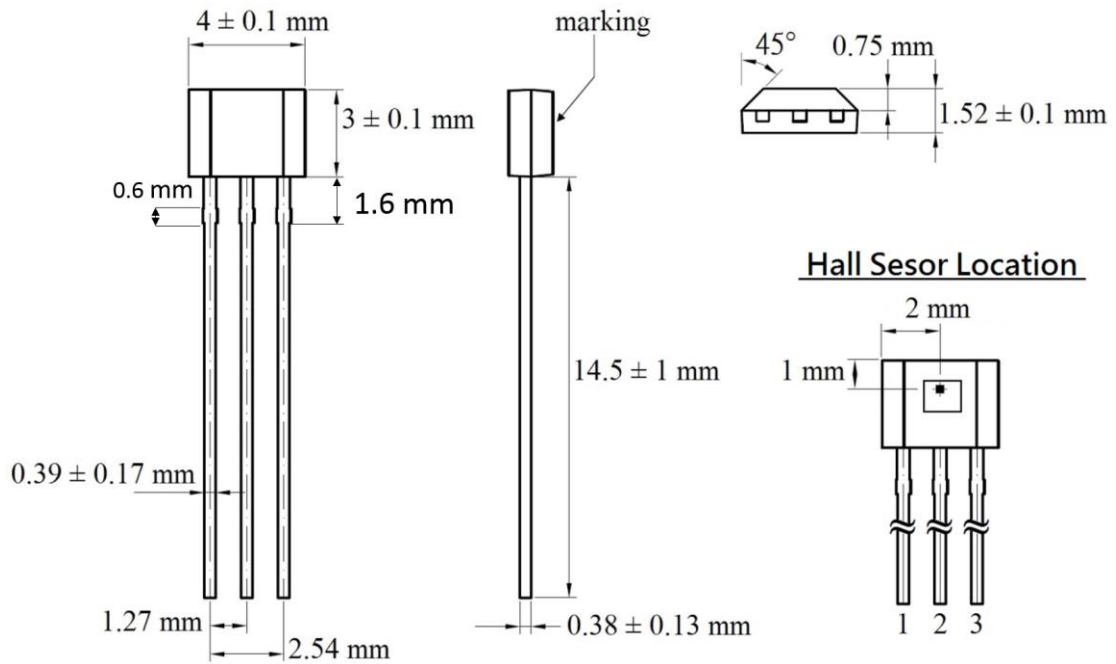

Winson reserves the right to make changes to improve reliability or manufacturability.

《SOT-23》

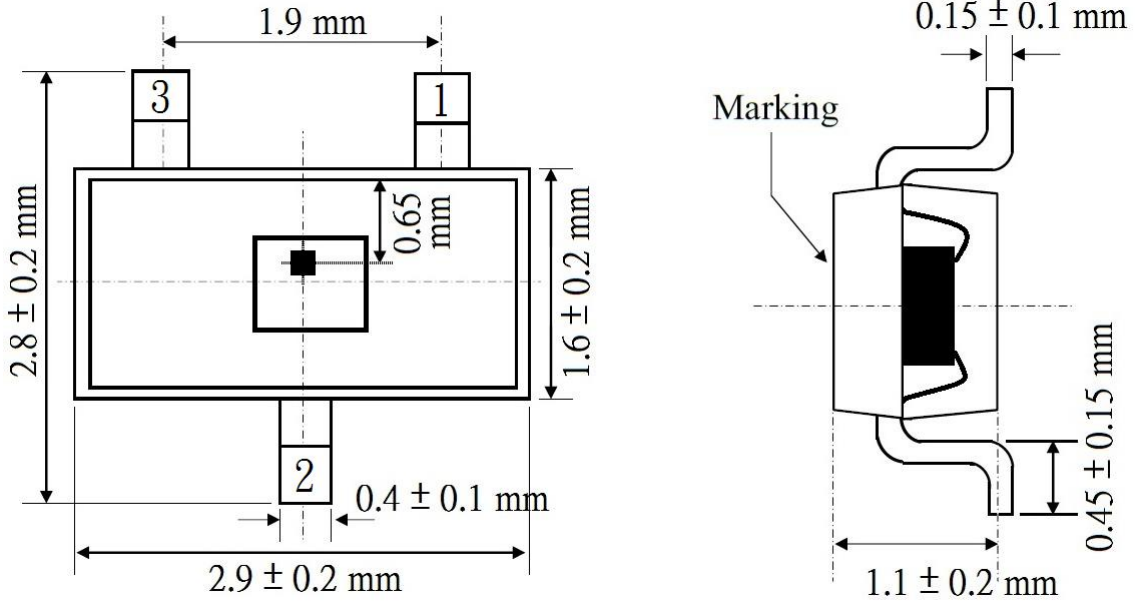

PCB Layout Reference View

SOT-23

TO-92S

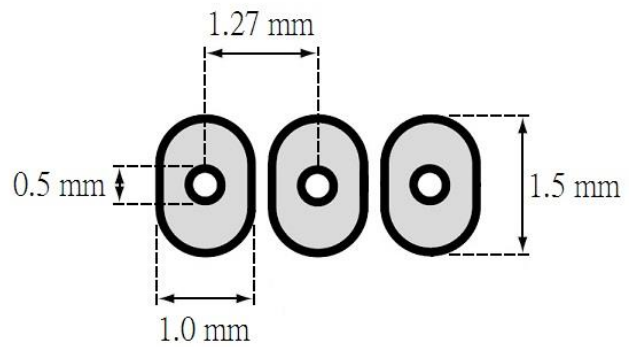
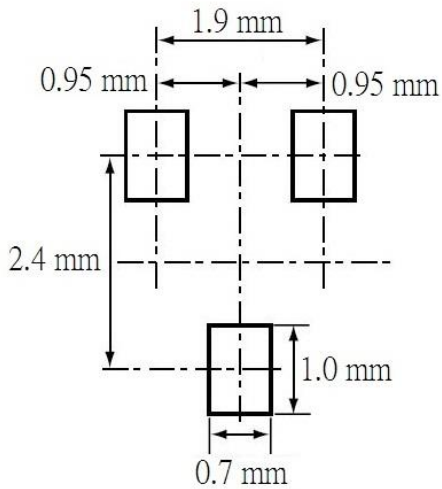

Winson reserves the right to make changes to improve reliability or manufacturability.

Characteristics Diagram:

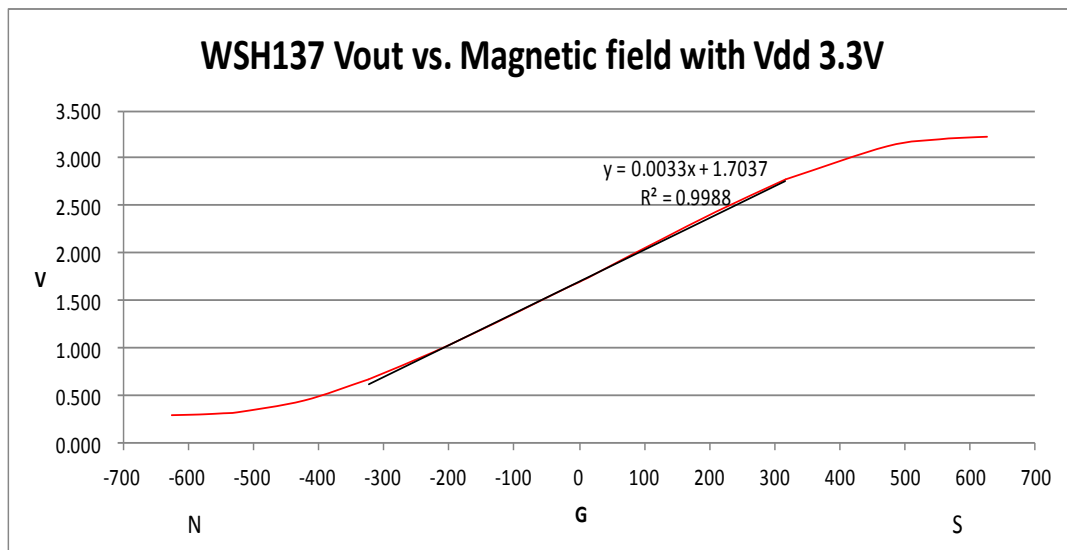
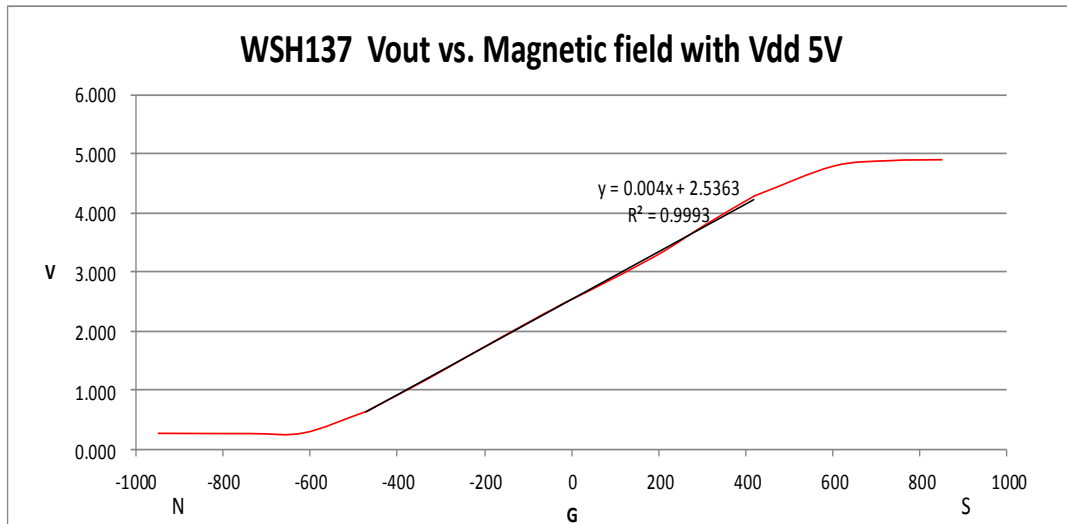
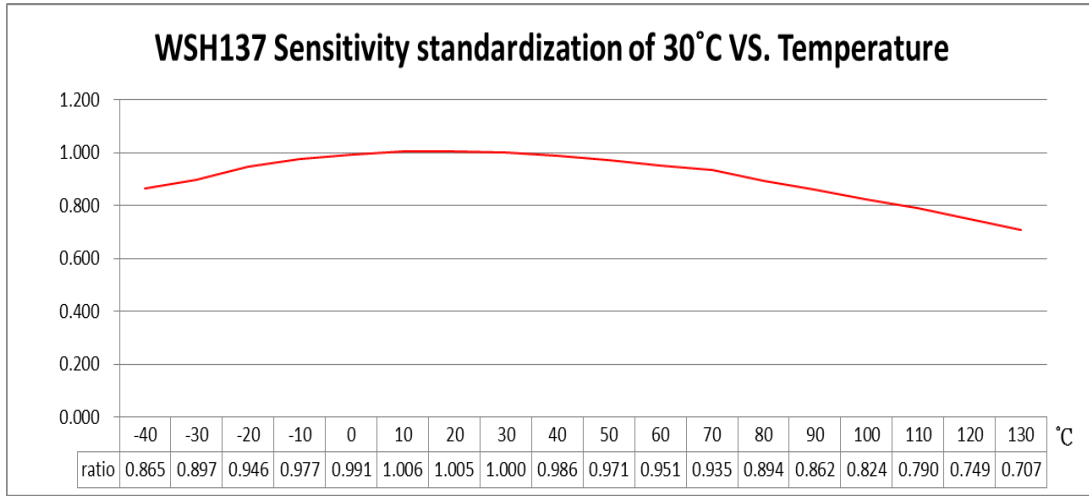

Winson reserves the right to make changes to improve reliability or manufacturability.

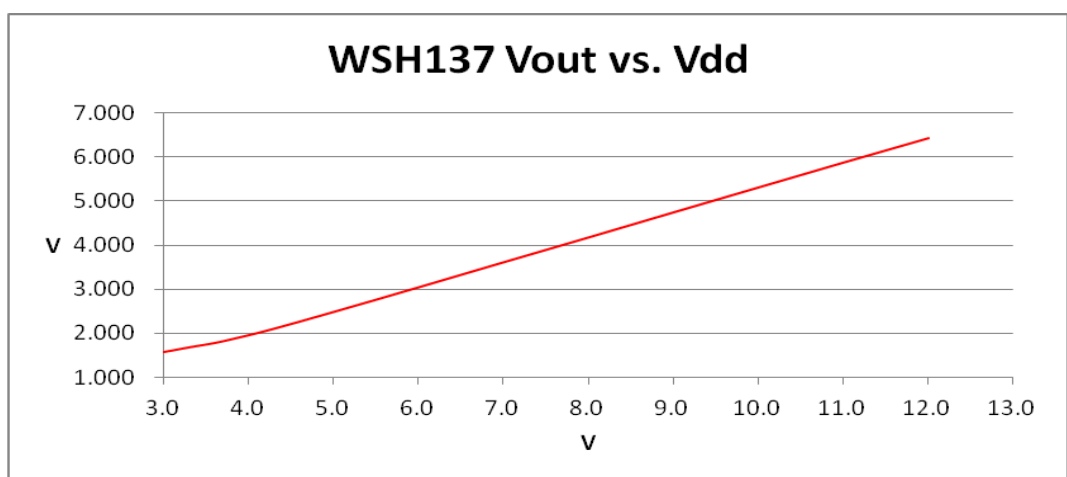
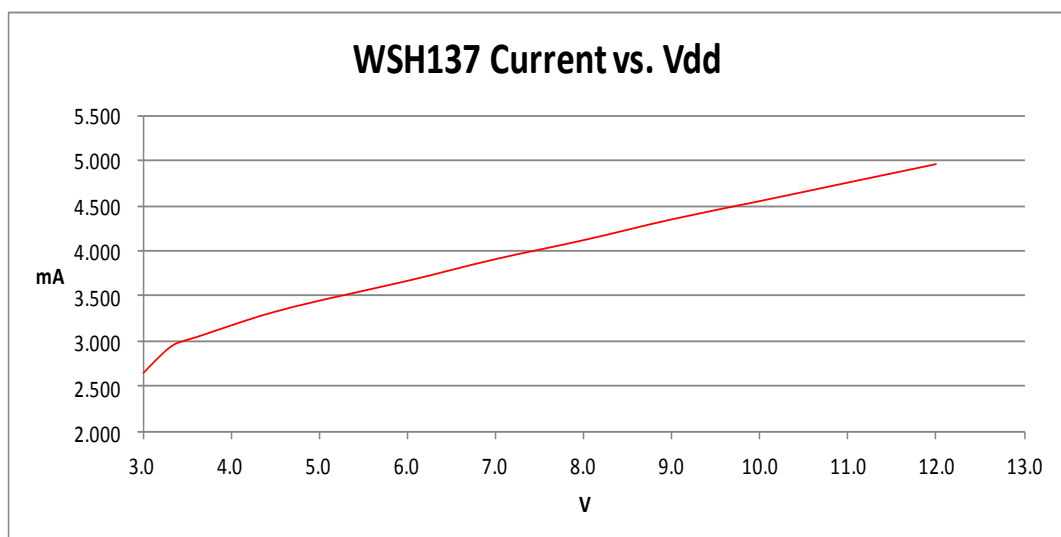
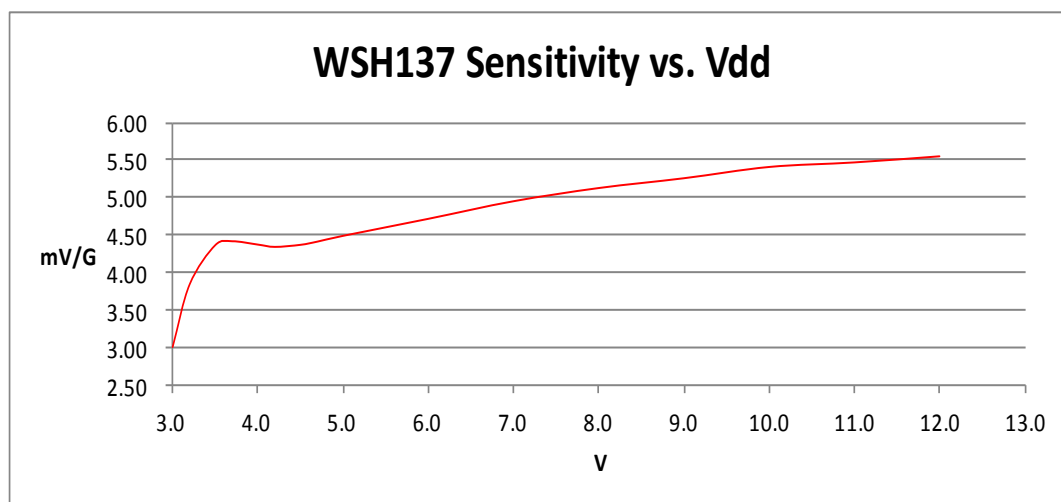

Precautions for the use of Hall Sensor IC: please refer to Winson Website->

Products->Application Note ->Hall Sensor IC Application Note:

<http://www.winson.com.tw/Product/83>

Winson reserves the right to make changes to improve reliability or manufacturability.