

General Description

The DW01 battery protection IC is designed to protect lithium-ion/polymer battery from damage or degrading the lifetime due to overcharge, overdischarge, and/or overcurrent for one-cell lithium-ion/polymer battery powered systems, such as cellular phones.

The ultra-small package and less required external components make it ideal to integrate the DW01 into the limited space of battery pack. The accurate $\pm 50\text{mV}$ overcharging detection voltage ensures safe and full utilization charging. The very low standby current drains little current from the cell while in storage.

Features

- Reduction in Board Size due to Miniature Package SOT-23-6.
- Ultra-Low Quiescent Current at $3\ \mu\text{A}$ ($V_{\text{CC}}=3.9\text{V}$).
- Ultra-Low Power-Down Current at $0.1\ \mu\text{A}$ ($V_{\text{CC}}=2.0\text{V}$).
- Precision Overcharge Protection Voltage $4.3\text{V} \pm 50\text{mV}$ for the DW01 Plus
- Load Detection Function during Overcharge Mode.
- Two Detection Levels for Overcurrent Protection.
- Delay times are generated by internal circuits. No external capacitors required.

Ordering Information

DW01

PACKAGE TYPE
SOT-23-6

TEMPERATURE RANGE
 $-40^{\circ}\text{C}\sim+85^{\circ}\text{C}$

OVERCHARGE PROTECTION
 $4.3\text{V} \pm 50\text{mV}$

Applications

- Protection IC for One-Cell Lithium-Ion / Lithium-Polymer Battery Pack

Product Name List

| Model | Package | Overcharge detection voltage [VocP] (V) | Overcharge release voltage [Vocr] (V) | Overdischarge detection voltage [VODP] (V) | Overdischarge release voltage [VODR] (V) | Overcurrent detection voltage [VoI1] (mV) |
|-------|----------|---|---------------------------------------|--|--|---|
| | SOT-23-6 | | | | | |
| DW01 | DW01A | 4.300±0.050 | 4.100±0.050 | 2.40±0.100 | 3.0±0.100 | 150±30 |

Pin Configuration

| Pin No. | Symbol | Description |
|---------|--------|--|
| 1 | OD | MOSFET gate connection pin for discharge control |
| 2 | CS | Input pin for current sense, charger detect |
| 3 | OC | MOSFET gate connection pin for charge control |
| 4 | TD | Test pin for reduce delay time |
| 5 | VCC | Power supply, through a resistor (R1) |
| 6 | GND | Ground pin |

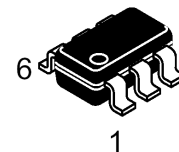
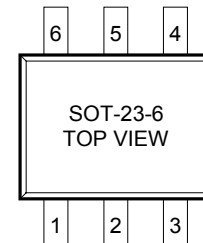

Functional Block Diagram

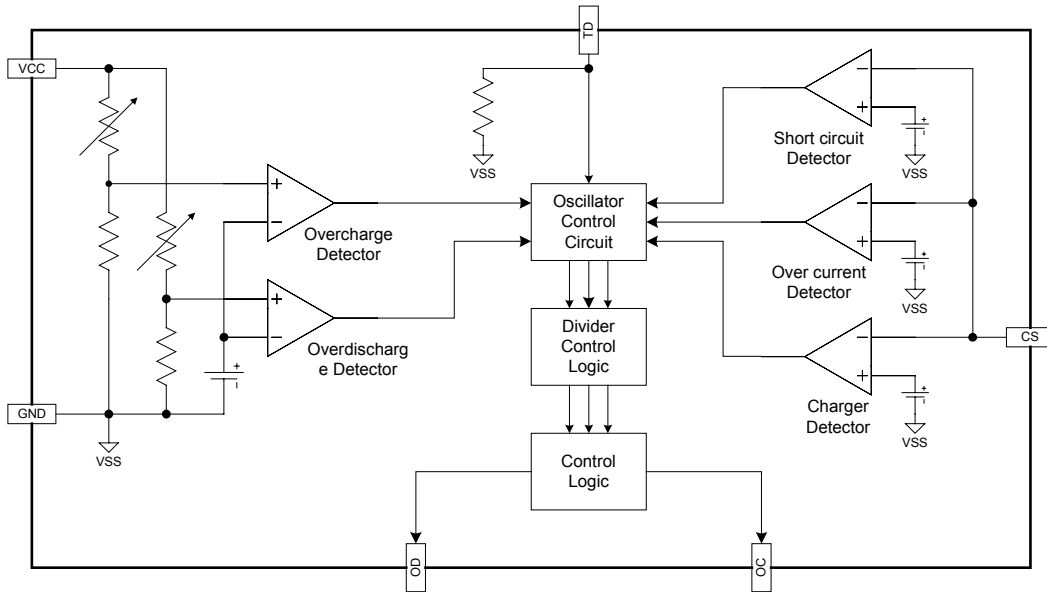

Typical Application Circuit

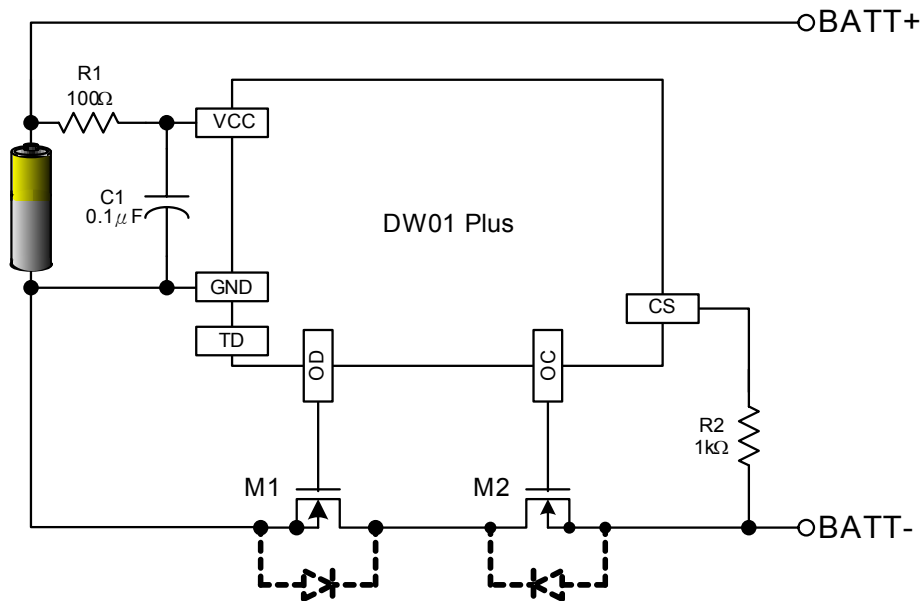

Absolute maximum Ratings (VSS=0V, Ta=25°C unless otherwise specified)

| Item | Symbol | Rating | Unit |
|-------------------------------------|--------|--------------------|------|
| Input voltage between VDD and VSS * | VDD | VSS-0.3 to VSS+10 | V |
| OC output pin voltage | Voc | VDD-26 to VDD+0.3 | V |
| OD output pin voltage | VOD | VSS-0.3 to VDD+0.3 | V |
| CS input pin voltage | Vcs | VDD-26 to VDD+0.3 | V |
| Operating Temperature Range | TOP | -40 to +85 | °C |
| Storage Temperature Range | TST | -40 to +125 | °C |

Note: DW01 Plus contains a circuit that will protect it from static discharge; but please take special care that no excessive static electricity or voltage which exceeds the limit of the protection circuit will be applied to it.

Electrical Characteristics

 (Ta=25°C unless otherwise specified)

| PARAMETER | TEST CONDITIONS | SYMBOL | Min | Typ | Max | UNIT |
|-------------------------------------|------------------|-------------|---------|----------|------|------|
| Supply Current | Vcc=3.9V | ICC | | 3.0 | 6.0 | μA |
| Power-Down Current | Vcc=2.0V | IPD | | | 0.1 | μA |
| Overcharge Protection Voltage | DW01 Plus | VOCP | 4.25 | 4.30 | 4.35 | V |
| Overcharge Release Voltage | | VOCR | 4.05 | 4.10 | 4.15 | V |
| Overdischarge Protection Voltage | | VODP | 2.30 | 2.40 | 2.50 | V |
| Overdischarge Release Voltage | | VODR | 2.90 | 3.00 | 3.10 | V |
| Overcurrent Protection Voltage | | VOIP (VOI1) | 120 | 150 | 180 | mV |
| Short Current Protection Voltage | Vcc=3.6V | VSIP (VOI2) | 1.25 | 1.35 | 1.45 | V |
| Overcharge Delay Time | | TOC | | 80 | 200 | ms |
| Overdischarge Delay Time | Vcc=3.6V to 2.0V | TOD | | 20 | 60 | ms |
| Overcurrent Delay Time (1) | Vcc=3.6V | TOI1 | | 10 | 20 | ms |
| Overcurrent Delay Time (2) | Vcc=3.6V | TOI2 | | 5 | 50 | μs |
| Charger Detection Threshold Voltage | | VCH | -1.2 | -0.7 | -0.2 | V |
| OD Pin Output "H" Voltage | | VDH | Vcc-0.1 | Vcc-0.02 | | V |
| OD Pin Output "L" Voltage | | VDL | | 0.1 | 0.5 | V |
| OC Pin Output "H" Voltage | | VCH | Vcc-0.1 | Vcc-0.02 | | V |
| OC Pin Output "L" Voltage | | VCL | | 0.1 | 0.5 | V |

Timing Diagram

1. Overcharge Condition → Load Discharging → Normal Condition

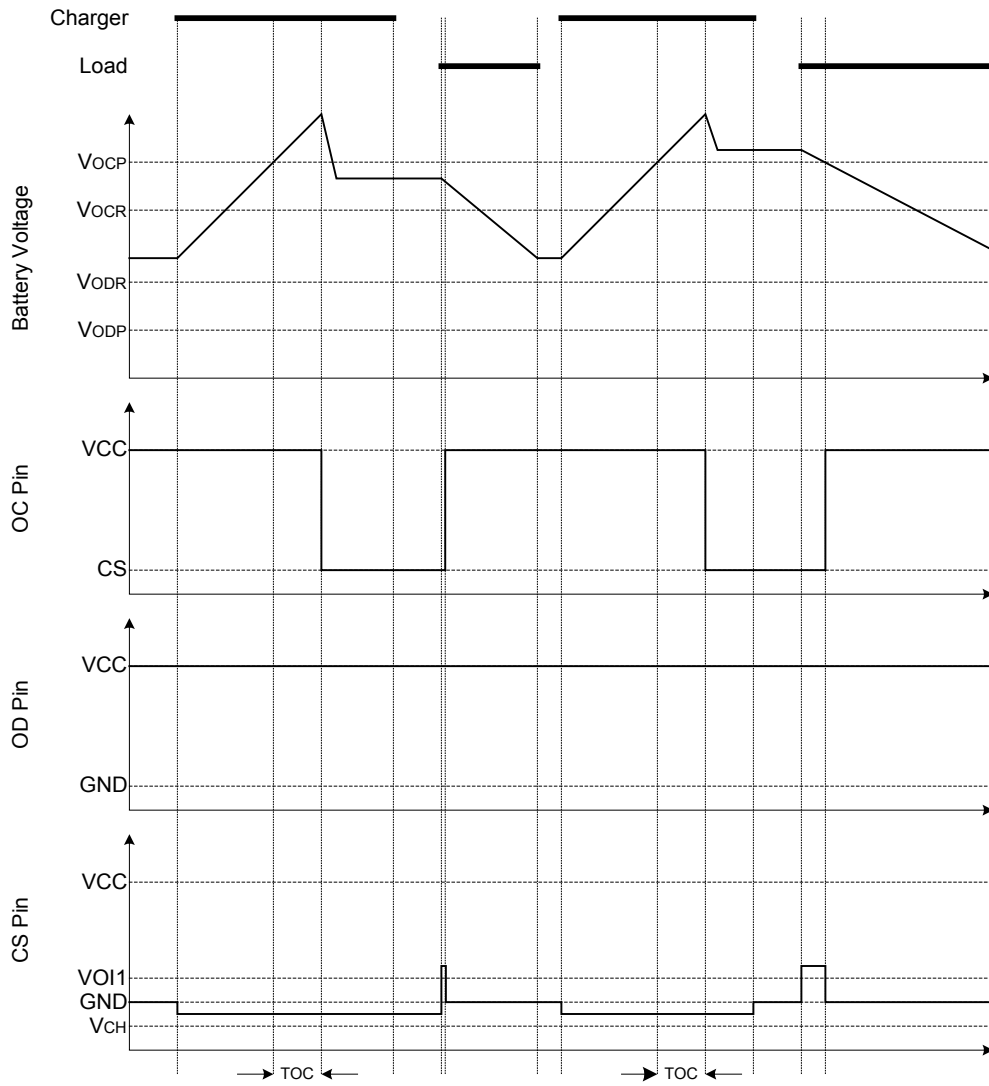

2. Overdischarge Condition → Charging by a Charger → Normal Condition

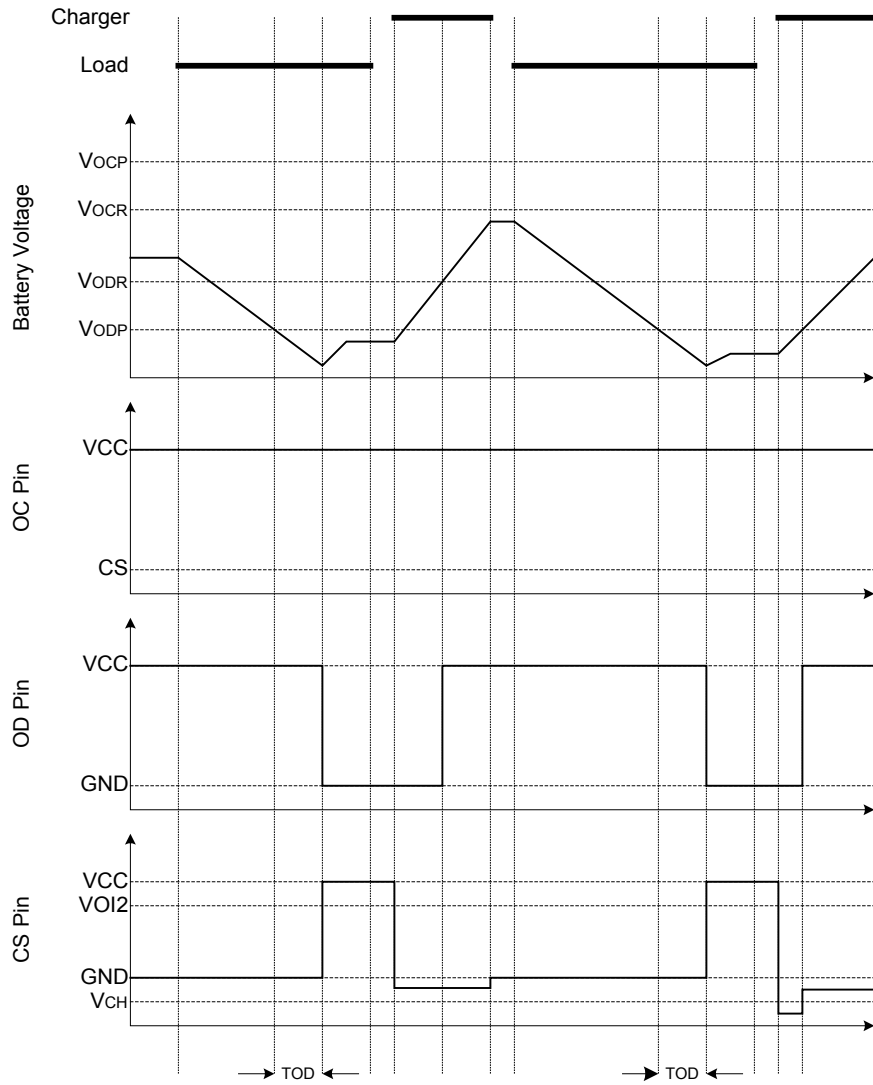

3. Over Current Condition → Normal Condition

