



20F-8, NO. 7 , Sec. 3, New Taipei Blvd., Xinzhuang Dist., New Taipei City

Web: <http://www.willtron.com.tw/>

Tel: +886 2 8522-7038 Fax: +886 2 8522-7069

SPECIFICATION

Model:WT-H-154D240I-CTP

For Customer's Acceptance:

Approved By	Comment		
PREPARED	CHECKED	VERIFIED BY QA DEPT	VERIFIED BY R&D DEPT

Table Of Contents

List	Description	Page No.
	Cover	1
	Revision Record	2
	Table Of Contents	3
1	Numbering System	4
2	General Information	4
3	External Dimensions	5
4	Interface Description	6
5	Absolute Maximum Ratings	6
6	Electrical Characteristics	7
7	Timing Characteristics	7
8	Backlight Characteristics	7
9	Optical Characteristics	8
10	Reliability Test Conditions And Methods	10
11	Inspection Standard	11
12	Handling Precautions	14
13	Precaution For Use	15
14	Packing Method	15

1. Numbering System

2. General Information

ITEM	STANDARD VALUES	UNITS
LCD type	1.54" TFT	--
Dot arrangement	240(RGB)×240	dots
Color filter array	RGB vertical stripe	--
Display mode	IPS / Transmissive / Normally Black	--
Viewing Direction	80/80/80/80	--
Driver IC	ST7789V	--
Module size	31.52(W)×33.72(H)×1.45(T)	mm
Active area	27.72(W)×27.72(H)	mm
Dot pitch	0.1155(W)×0.1155(H)	mm
Interface	SPI	--
Operating temperature	-20 ~ +70	°C
Storage temperature	-30 ~ +80	°C
Back Light	3 White LED	--
Weight	TBD	g

3. External Dimensions

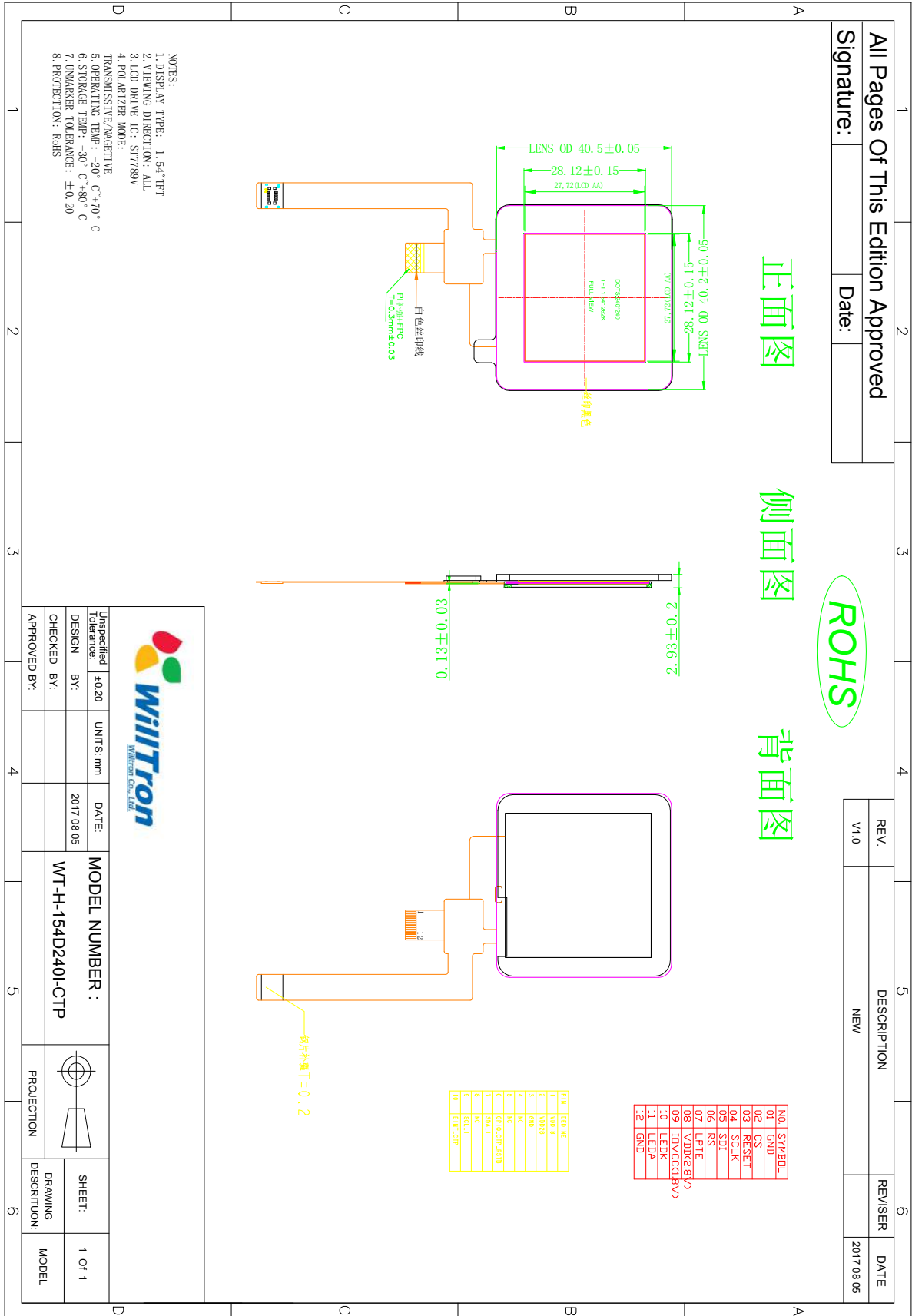

4. LCM Interface Description

PIN NO.	PIN NAME	DESCRIPTION
1	GND	System power ground.
2	CS	Chip select input pin ("Low" enable).
3	RESET	Reset signal input terminal, active at 'L'.
4	SCLK	This pin is used serial interface clock in SPI.
5	SDA	Serial input signal in SPI I/F.
6	D/C(RS)	Serves as command or parameter select.
7	FMARK	TE single
8	VCI	System power supply;(2.8~3.3V)
9	IOVCC	IO System power supply.(1.8V)
10	LEDK	Power supply for backlight cathode input terminal.
11	LEDA	Power supply for backlight anode input terminal.
12	GND	System power ground.

TP Pin Interface

PIN NO.	PIN NAME	DESCRIPTION
1	IOVCC(1.8V)	System power supply.
2	VCC(2.8V)	System power supply.
3	GND	System power ground.
4	NC	
5	NC	
6	CTP_RST	TP Reset signal input terminal, active at 'L' .
7	CTP_SDA	TP SDA signal input terminal
8	NC	NC
9	CTP_SCL	TP SCL clock signals.
10	CTP_INT	TP INT signal input terminal

5. Absolute Maximum Ratings

Item	Symbol	Min.	Max.	Unit
Logic Supply Voltage	IOVCC	-0.3	4.6	V
Analog Supply Voltage	VCC	-0.3	4.6	V
Input Voltage	Vin	-0.3	IOVCC+0.3	V
Operating Temperature	TOP	-20	70	°C

Storage Temperature	T _{ST}	-30	80	°C
Storage Humidity	HD	20	90	%RH

6. DC Characteristics

Item	Symbol	Min.	Typ.	Max.	Unit	Remark
Logic Supply Voltage	IOVCC	1.65	-	3.3	V	-
Analog Supply Voltage	VCC	2.5	-	3.3	V	-
Input High Voltage	V _{IH}	0.7IOVCC	-	IOVCC	V	Digital input pins
Input Low Voltage	V _{IL}	GND	-	0.3IOVCC	V	Digital input pins
Output High Voltage	V _{OH}	0.8IOVCC	-	IOVCC	V	Digital output pins
Output Low Voltage	V _{OL}	GND	-	0.2IOVCC	V	Digital output pins
I/O Leak Current	I _{LI}	-1.0	-	1.0	uA	-

7. Timing Characteristics

7.1 Timing Characteristics of the SPI

Please see the IC datasheet.

7.2 Reset Timing Characteristics

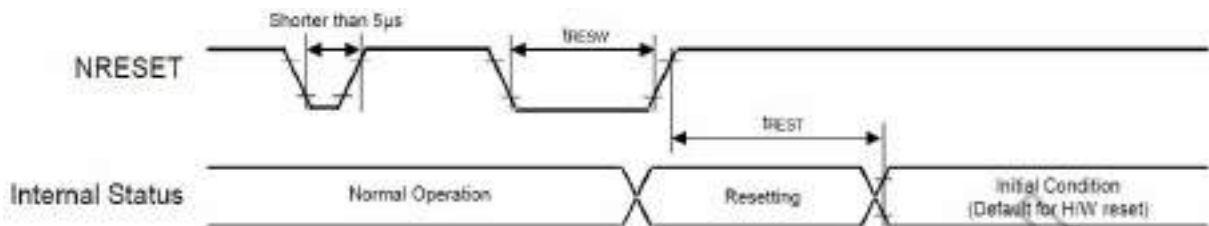

Symbol	Parameter	Related Pins	Spec.			Note	Unit
			Min.	Typ.	Max.		
t _{RESW}	Reset low pulse width ⁽¹⁾	NRESET	10	-	-	-	µs
t _{REST}	Reset complete time ⁽²⁾	-	5	-	-	When reset applied during SLPIN mode	ms
		-	120	-	-	When reset applied during SLPOUT mode	ms

8. Backlight Characteristics

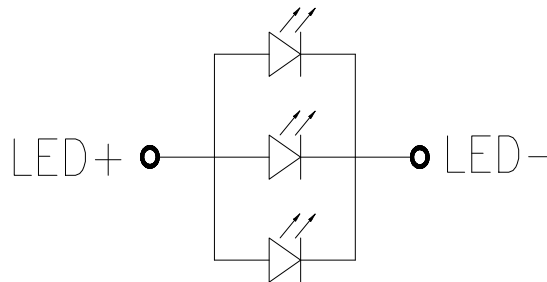

Item	Symbol	MIN	TYP	MAX	UNIT	Test Condition
Supply Voltage	V _f	3.0	3.2	3.5	V	I _f =60mA

Supply Current	If	-	60	75	mA	-
Luminous Intensity for LCM	-	450	500	-	Cd/m ²	If=60mA
Life Time	-	20000	-	-	Hr	If=60mA
Backlight Color	White					

9. Optical Characteristics

Parameter		Symbol	Condition	Min.	Typ.	Max.	Unit	Remark
Threshold Voltage Fig.1		VsatV		4.1	4.3	4.5	V	
		Vth		1.6	1.8	2.0	V	
Viewing Angle	Horizontal	Θ3	CR>10		80		°	Note 1
		Θ9			80		°	
	Vertical	Θ12			80		°	
		Θ6°			80		°	
Contrast Ratio		CR	Θ= 0°		900			Note 2
Transmittance		T(%)	Θ= 0°		5.5			Note 3
NTSC		%	Θ= 0°		50			
Reproduction Of color	Red	Rx	Θ= 0°	0.611	0.626	0.641		Note 4 *CF glass With OC
		Ry		0.295	0.310	0.325		
	Green	Gx		0.281	0.296	0.311		
		Gy		0.503	0.518	0.533		
	Blue	Bx		0.129	0.144	0.159		
		By		0.124	0.139	0.154		
White		Wx	Θ= 0°	0.280	0.295	0.310		
		Wy		0.310	0.325	0.340		
Response Time		Tr+Tf	Θ= 0°		35	50	ms	Note 5

Note 1. Ambient condition : 25±2°C , 60±10%RH , under 10 Lux in the darkroom .

Note 2. Measure device: BM-5A(TOPCON), viewing cone=1° , IL=20mA, after 10 minutes operation.

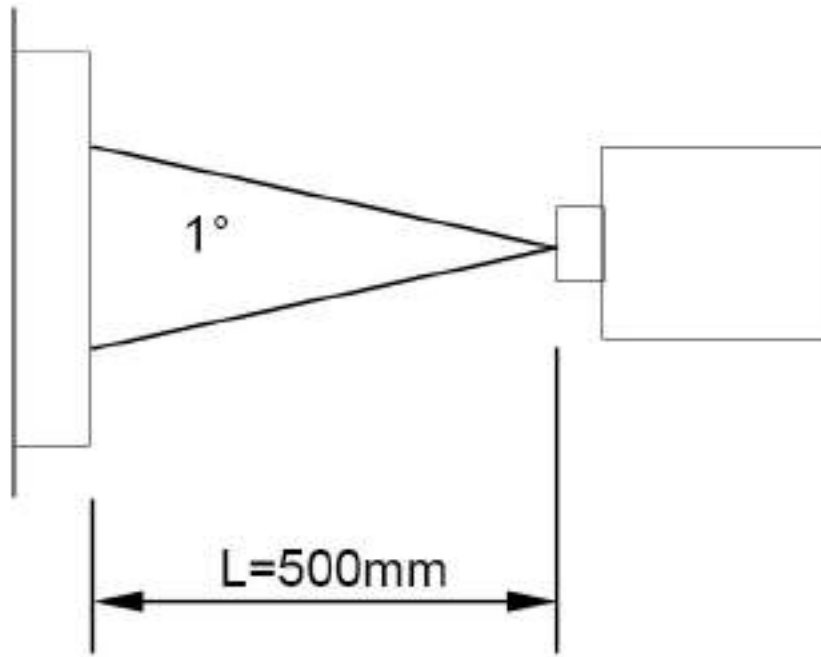

Note 3. Definition of Luminance Uniformity : $L = L(\text{MIN}) / L(\text{MAX}) \times 100\%$

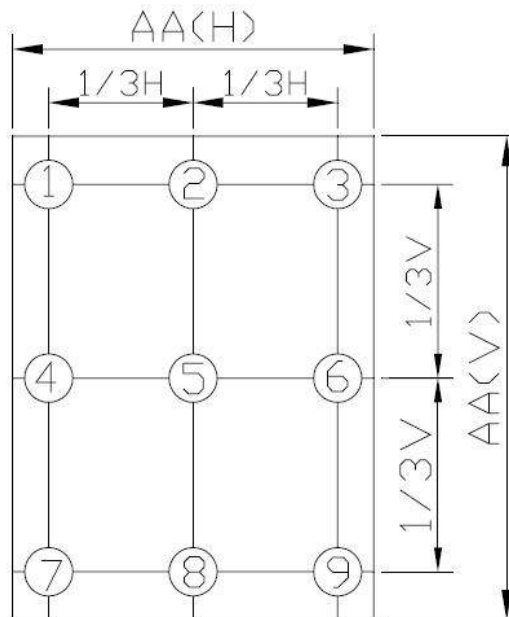

Note 4. Definition of Contrast Ratio :

$$\text{CR} = \text{White Luminance (ON)} / \text{Black Luminance (OFF)}$$

Note 5. Definition of response time : The response time is defined as the time interval between the 10% and 90% amplitudes.

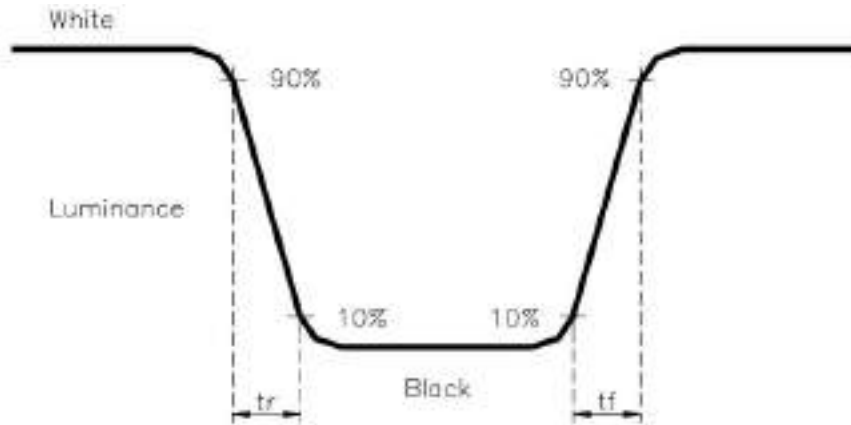

Note 6. Definition of view angle(θ , ψ) :

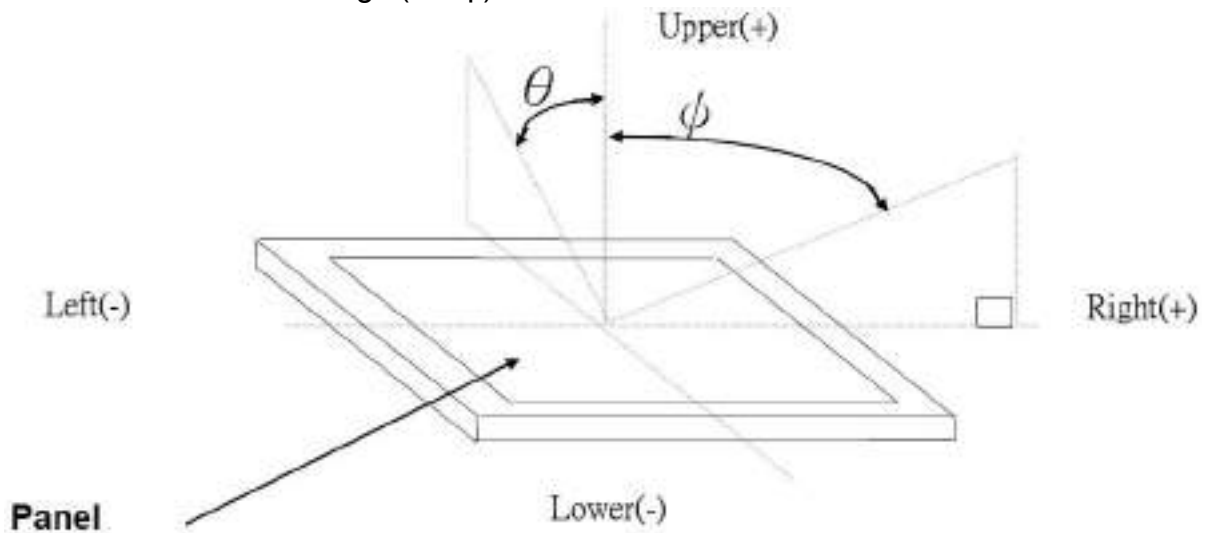

10. Reliability Test Conditions And Methods

NO.	TEST ITEMS	TEST CONDITION	INSPECTION AFTER TEST
①	High Temperature Storage	80°C±2°C×96Hours	Inspection after 2~4hours storage at room temperature,the samples should be free from defects: 1,Air bubble in the LCD. 2,Sealleak. 3,Non-display. 4,Missing segments. 5,Glass crack. 6,Current IDD is twice higher than initial value. 7,The surface shall be free from damage. 8,The electric charateristic
②	Low Temperature Storage	-30°C±2°C×96Hours	
③	High Temperature Operating	70°C±2°C×96Hours	
④	Low Temperature Operating	-20°C±2°C×96Hours	
⑤	Temperature Cycle(Storage)	-20°C ↔ 25°C ↔ 70°C (30min) ← (5min) → (30min) 1cycle Total 10cycle	

⑥	Damp Proof Test (Storage)	50°C±5°C×90%RH×96Hours	requirements shall be satisfied.
⑦	Vibration Test	Frequency:10Hz~55Hz~10Hz Amplitude:1.5M X,Y,Z direction for total 3hours (Packing Condition)	
⑧	Drooping Test	Drop to the ground from 1M height one time every side of carton. (Packing Condition)	
⑨	ESD Test	Voltage:±8KV,R:330Ω,C:150PF,Air Mode,10times	

REMARK:

- 1,The Test samples should be applied to only one test item.
- 2,Sample side for each test item is 5~10pcs.
- 3,For Damp Proof Test,Pure water(Resistance > 10MΩ)should be used.
- 4,In case of malfunction defect caused by ESD damage,if it would be recovered to normal state after resetting,it would be judge as a good part.
- 5,EL evaluation should be excepted from reliability test with humidity and temperature:Some defects such as black spot/blemish can happen by natural chemical reaction with humidity and Fluorescence EL has.
- 6,Failure Judgment Criterion:Basic Specification Electrical Characteristic,Mechanical Characteristic,Optical Characteristic.

11. Inspection Standard

This standard apply to C-STN/TFT module

1. Spot check plan:

According to spot check level II ,MIL-STD-105D Level II ,the rank of accept or reject is below:

3A 级、2A 级：major non-conformance: AQL 0.25 minor non-conformance: AQL 0.4

A 级：major non-conformance: AQL 0.65 minor non-conformance: AQL 1.

2. Inspection condition:

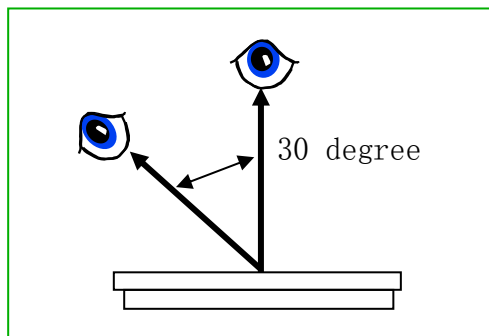

Under daylight lamp 20 ~ 40W , product distance inspector'eye 30cm,incline degree 30°.

3. LCD area define:

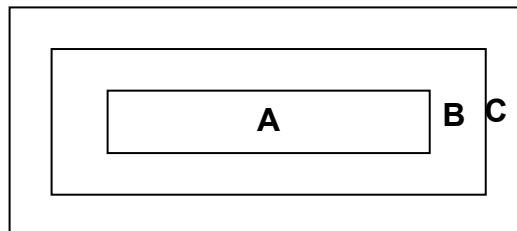

Area A: display area

Area B: VA area

Area C: out of VA area,not in sight after assembly

Remark :non-conformance at area C,but is OK that isn't influence reliability of product & assembly by customer.

4. Inspection standard

4.1 Major non-conformance

NO.	Item	Inspection standard	Rate
4.1.1	Function non-conformance	1) No display, display abnormally 2) Miss line, short 3) B/L no function or function abnormally 4) TP no function	major
4.1.2	miss	No matter miss what component	
4.1.3	Out of size	Module dimension out of spec	

4.2 Appearance non-conformance

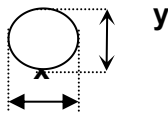
NO.	Item	Inspection standard	Rate																														
4.2.1	Black or white spot (power on)	dot non-conformance define Φ $\Phi = \frac{(x+y)}{2}$ 	Minor																														
		A grade																															
		<table border="1"> <thead> <tr> <th rowspan="2">area size (mm)</th> <th colspan="3">Most approve q'ty</th> </tr> <tr> <th>A</th> <th>B</th> <th>C</th> </tr> </thead> <tbody> <tr> <td>$\Phi \leq 0.10$</td> <td colspan="3">ignore</td> </tr> <tr> <td>$0.10 < \Phi \leq 0.15$</td> <td>3</td> <td colspan="2" rowspan="3">ignore</td> </tr> <tr> <td>$0.15 < \Phi \leq 0.20$</td> <td>2</td> </tr> <tr> <td>$0.20 < \Phi \leq 0.25$</td> <td>1</td> </tr> <tr> <td>$0.25 < \Phi$</td> <td>0</td> <td colspan="2"></td> </tr> </tbody> </table>		area size (mm)	Most approve q'ty			A	B	C	$\Phi \leq 0.10$	ignore			$0.10 < \Phi \leq 0.15$	3	ignore		$0.15 < \Phi \leq 0.20$	2	$0.20 < \Phi \leq 0.25$	1	$0.25 < \Phi$	0									
		area size (mm)			Most approve q'ty																												
				A	B	C																											
		$\Phi \leq 0.10$		ignore																													
$0.10 < \Phi \leq 0.15$	3	ignore																															
$0.15 < \Phi \leq 0.20$	2																																
$0.20 < \Phi \leq 0.25$	1																																
$0.25 < \Phi$	0																																
Most approve 4 damages, dot to dot $\geq 10\text{mm}$																																	
4.2.2	Black or white line (power on)	A grade	Minor																														
		<table border="1"> <thead> <tr> <th colspan="2">Size(mm)</th> <th colspan="3">Most approve q'ty</th> </tr> <tr> <th>L(length)</th> <th>W(width)</th> <th>A</th> <th>B</th> <th>C</th> </tr> </thead> <tbody> <tr> <td>ignore</td> <td>$W \leq 0.03$</td> <td colspan="3">ignore</td> </tr> <tr> <td>$L \leq 5.0$</td> <td>$0.03 < W \leq 0.05$</td> <td colspan="3">2</td> </tr> <tr> <td>$L \leq 3.0$</td> <td>$0.05 < W \leq 0.07$</td> <td colspan="3">1</td> </tr> <tr> <td></td> <td>$0.07 < W$</td> <td colspan="3">Treat with dot non-conformance</td> </tr> </tbody> </table>		Size(mm)		Most approve q'ty			L(length)	W(width)	A	B	C	ignore	$W \leq 0.03$	ignore			$L \leq 5.0$	$0.03 < W \leq 0.05$	2			$L \leq 3.0$	$0.05 < W \leq 0.07$	1				$0.07 < W$	Treat with dot non-conformance		
		Size(mm)		Most approve q'ty																													
		L(length)		W(width)	A	B	C																										
		ignore		$W \leq 0.03$	ignore																												
$L \leq 5.0$	$0.03 < W \leq 0.05$	2																															
$L \leq 3.0$	$0.05 < W \leq 0.07$	1																															
	$0.07 < W$	Treat with dot non-conformance																															
Most approve 3 damages, line to line $\geq 10\text{mm}$																																	

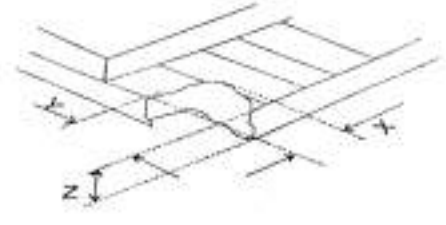
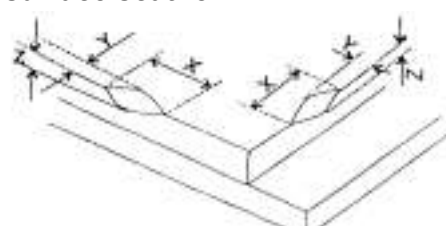
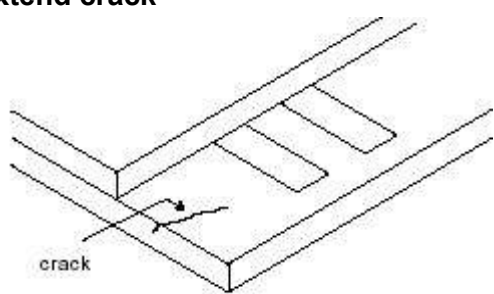
4.2.3	Polarizer position	1) polarizer attach meet drawing, disallow out of LCD. 2) polarizer must cover display area (special require unless)	Minor						
4.2.4	LCD non-conformance	(i) crash at side (remark: S=ITO length)  <table border="1" data-bbox="558 672 1197 772"> <thead> <tr> <th>X</th> <th>Y</th> <th>Z</th> </tr> </thead> <tbody> <tr> <td>≤3.0</td> <td>≤S</td> <td>ignore</td> </tr> </tbody> </table> <p>Crash disallow extend to ITO or seal.</p>	X	Y	Z	≤3.0	≤S	ignore	Minor
		X	Y	Z					
		≤3.0	≤S	ignore					
(ii) commonly surface scathe  <table border="1" data-bbox="542 1108 1220 1198"> <thead> <tr> <th>X</th> <th>Y</th> <th>Z</th> </tr> </thead> <tbody> <tr> <td>≤2.0</td> <td><frame edge</td> <td>ignore</td> </tr> </tbody> </table>	X	Y	Z	≤2.0	<frame edge	ignore			
X	Y	Z							
≤2.0	<frame edge	ignore							
(iii) crack Disallow extend crack 									
4.2.5	Contrast voltage warp	VOP/Vlcd voltage of confirmed sample ±0.15V	Minor						
4.2.6	color	Color & luminance of module scope reference spec	Minor						
4.2.7	Cross talk	Reference confirmed limit sample	Minor						

12. Handling Precautions

12.1 Mounting method

The LCD panel of SC LCD module consists of two thin glass plates with polarizers which easily be damaged. And since the module is so constructed as to be fixed by utilizing fitting holes in the printed circuit board.

Extreme care should be needed when handling the LCD modules.

12.2 Caution of LCD handling and cleaning

When cleaning the display surface, Use soft cloth with solvent
[recommended below] and wipe lightly

- Isopropyl alcohol
- Ethyl alcohol

Do not wipe the display surface with dry or hard materials that will damage the polarizer surface.

Do not use the following solvent:

- Water
- Aromatics

Do not wipe ITO pad area with the dry or hard materials that will damage the ITO patterns

Do not use the following solvent on the pad or prevent it from being contaminated:

- Soldering flux
- Chlorine (Cl) , Sulfur (S)

If goods were sent without being silicon coated on the pad, ITO patterns could be damaged due to the corrosion as time goes on.

If ITO corrosion happens by miss-handling or using some materials such as Chlorine (Cl), Sulfur (S) from customer, Responsibility is on customer.

12.3 Caution against static charge

The LCD module uses C-MOS LSI drivers, so we recommend that you:

Connect any unused input terminal to Vdd or Vss, do not input any signals before power is turned on, and ground your body, work/assembly areas, assembly equipment to protect against static electricity.

12.4 packing

- Module employs LCD elements and must be treated as such.
- Avoid intense shock and falls from a height.
- To prevent modules from degradation, do not operate or store them exposed directly to sunshine or high temperature/humidity

12.5 Caution for operation

- It is an indispensable condition to drive LCD's within the specified voltage limit since the higher voltage than the limit causes the shorter LCD life.
- An electrochemical reaction due to direct current causes LCD's undesirable deterioration, so that the use of direct current drive should be avoided.
- Response time will be extremely delayed at lower temperature than the operating temperature range and on the other hand at higher temperature LCD's show dark color in them. However those phenomena do not mean malfunction or out of order with LCD's, which will come back in the specified operation temperature.
- If the display area is pushed hard during operation, some font will be abnormally displayed but it resumes normal condition after turning off once.
- A slight dew depositing on terminals is a cause for electro-chemical reaction resulting in terminal open circuit.

Usage under the maximum operating temperature, 50%Rh or less is required.

12.6 storage

In the case of storing for a long period of time for instance, for years for the purpose or replacement use, the following ways are recommended.

- Storage in a polyethylene bag with the opening sealed so as not to enter fresh air outside in it . And with no desiccant.
- Placing in a dark place where neither exposure to direct sunlight nor light's keeping the storage temperature range.
- Storing with no touch on polarizer surface by the anything else.
[It is recommended to store them as they have been contained in the inner container at the time of delivery from us

12.7 Safety

- It is recommendable to crash damaged or unnecessary LCD's into pieces and wash off liquid crystal by either of solvents such as acetone and ethanol, which should be burned up later.
- When any liquid leaked out of a damaged glass cell comes in contact with your hands, please wash it off well with soap and water

13. Precaution For Use

13.1

A limit sample should be provided by the both parties on an occasion when the both parties agreed its necessity. Judgment by a limit sample shall take effect after the limit sample has been established and confirmed by the both parties.

13.2

On the following occasions, the handing of problem should be decided through discussion and agreement between responsible of the both parties.

- When a question is arisen in this specification
- When a new problem is arisen which is not specified in this specifications
- When an inspection specifications change or operating condition change in customer is reported to LCD , and some problem is arisen in this specification due to the change
- When a new problem is arisen at the customer's operating set for sample evaluation in the customer site.

14. Packing Method

