

## WT2000 B03

---

V1.02

**Note:**

WAYTRONIC ELECTRONIC CO.,LTD. reserves the right to change this document without prior notice. Information provided by WAYTRONIC is believed to be accurate and reliable. However, WAYTRONIC makes no warranty for any errors which may appear in this document. Contact WAYTRONIC to obtain the latest version of device specifications before placing your orders. No responsibility is assumed by WAYTRONIC for any infringement of patent or other rights of third parties which may result from its use. In addition,WAYTRONIC products are not authorized for use as critical components in life support devices/systems or aviation devices/systems, where a malfunction or failure of the product may reasonably be expected to result in significant injury to the user, without the express written approval of WAYTRONIC.



## 1. Overview

WT2000B03 is a kind of MP3 module, with folder classification, specified file-name play and specified index sequence play. According file name to record in specified file or according index sequence to record and play. Support SPI-Flash, SD card and U disk.





## 2. Features

- Support WAV, WMA, MP3 format.
- SPI-FLASH, micro SD card, U disk as storage, maximum support 32G micro SD card and 32G U disk.
- Built-in memory can store 1999 pieces of voice.
- Support combination play in the same storage.
- Support inter-cut in different storage.
- Connect with computer, through USB interface to renewal micro SD card audio.
- Support USB sound card.
- Support UART communication, with standard interface protocol.
- Inner 1W amplifier, direct drive 8ohm/1w speaker, with 32 level volume.
- DC 5V power supply.

## 3. Specification

Name	Function
Audio Format	Support 8K-48K sample rate, 8-320Kbps bit rate Support 8K-44.1K sample rate WAV audio file Support 8K-44.1K sample rate WMA audio file
Store Volume	Support 4Mbit-128Mbit SPI-FLASH Max support 32GB micro SD card Max support 32GB U disk
USB Interface	Full speed 2.0
Power Supply	DC3.3~5V
Rated Current	20~250mA (related with load)
IO Port Level	3.3V TTL Level
Size	21.3mm*37.2mm
Working Temperature	-40~85 degree
Humidity	5%~95%

## 4. Pin description

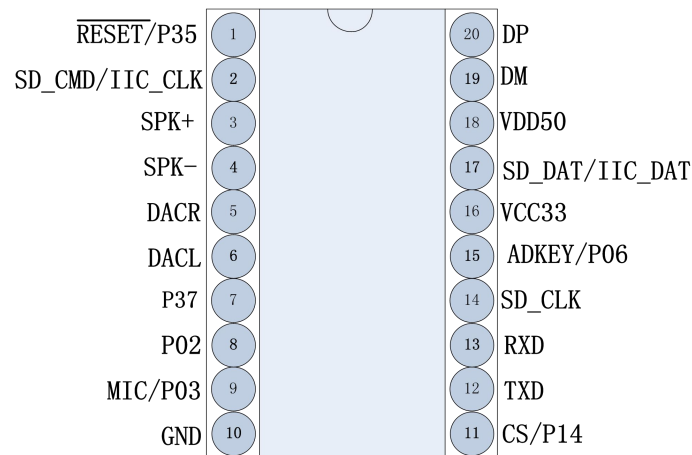

**WT2000B03**

Pin No.	Name	Type	Function Description
1	RESET/P35	I	Inner storage to control pin (it need to control the pin when external downloader download audio into inner storage)
2	SD_CMD/IIC_CLK	PWP	Connect CMD port of SD card
3	SPK+	AO	Speaker connector
4	SPK-	AO	Speaker connector
5	DACR	IO	DAC right channel output
6	DACL	IO	DAC left channel output
7	P37	I	Input terminal of SPI-FLASH clock signal interface
8	P02	I	Input terminal of SPI-FLASH data signal interface
9	MIC/P03	I/O	Microphone connector(not used currently)
10	GND	PWP	Power Ground
11	CS/P14	I/O	Internal storage SPI-FLASH CS interface input terminal
12	TXD	O	UART asynchronous serial data output port
13	RXD	I	UART asynchronous serial data input port
14	SD-CLK	I	External SD card interface of clock signal input terminal
15	ADKEY/P06	I	ADC key connecting end
16	VCC33	PWP	LDO 3.3V power output terminal
17	SD_DAT/IIC_DAT	I	UART asynchronous serial data input terminal
18	VDD50	PWP	Module power supply terminal
19	DM	IO	USB data terminal DM
20	DP	IO	USB data terminal DP

**Note:**

Power output terminal VDD33 is not allowed to supply power to external device, so as not to effect module working, only for low power consumption device like pull-up resistor.



## 5. Electric parameter

Name	Remark	Condition	Min. value	Typical value	Max. value	Unit
VDD50	LDO input voltage	-	3.2	5.0	5.5	V
VDD33	LDO 3.3V output voltage	Vout3.3>3.1V	-	-	150	mA
Quiescent current	Current under no load	No load		30		mA
Working current	Current in playing state	8R/1W speaker, 31-level volume		390		mA
SNR	Signal to noise ratio	-	-	92	-	dB
THD+N	Total harmonic distortion	Idle load	-	-70	-	dB
PWRAB	DAC output power	32 ohm speaker	-	-	16	mW
VPP	DAC max output voltage	10K ohm load	-	-	2.8	V
Ps1	Standby power consumption (with SD card)	Related with SD card power consumption	-	27.6	-	Ma
Prec	Recording power consumption (with SD card)	Related with SD card power consumption	-	28.1	-	Ma
P	Power consumption when playing (Idle Load)	Related with SD card power consumption	-	28.7	-	Ma
VPPLINE	External audio input		-	-	2.8	V

## 6. Control mode

### 6.1 Key Control

Key Name	K1	K2	K3	K4
Operation	Short press	Short press	Short press	Short press
Function	Play/Pause	Choose the next file	Chose the previous file	Stop playing

Key connecting circuit, please refer to below application circuit.

### 6.2 Serial port control

#### 6.2.1 Protocol command format

WT2000B03 is built in standard UART asynchronous serial interface, belonging to 3.3V TTL level interface. Through MAX3232 chip converted into RS232 level.

Communication data format: start bit: 1 digit, data bit: 8 digit, parity bit: none, stop bit: 1 digit. Use computer serial debug assistance to set correct serial port parameter, shown below:



Serial port :	COM1	
Baud rate :	9600	
Check bit :	None	
Stop bit :	8	
Data bit :	1	
	<input checked="" type="radio"/>	Send in Hex format
	<input type="radio"/>	Send in Chars format

Start Bit	Length	Operation Code	Parameter	Cumulative sum check	End Code
0X7E	See below	See below	See below	See below	0XEF

**Note:** all data are hexadecimal number. “Length” means length (1 byte) + command code(several bytes) + parameter(several bytes) + check sum (1byte). “Cumulative sum check” means length + command code +low byte of parameter cumulative sum.

## 6.2.2 Command List

### Communication Control Command

CMD	Corresponding Function	Parameter
A0	Specified SPI FLASH root directory index play	File index
A1	Specified file play in SPI FLASH folder	Folder, file index
A2	Specified SD card root directory index play	File index
A3	Specified file name play in SD card	File name
A4	Specified file index play in SD card folder	Folder name, file name
A5	Specified folder name play in SD card folder	Folder name, file name
A6	Specified U disk root directory index play	File index
A7	Specified U disk file name play	File name
A8	Specified file index play in U disk folder	Folder name, file index
A9	Specified file index play in U disk folder	Folder name, file index
AA	Pause command	None
AB	Stop command	None
AC	Next command	None
AD	Previous command	None
AE	Volume control command	Volume level
AF	Specified play mode	Cycle mode
B0	Combination play command	File index



B1	Inter-cut command	Work drive letter, file index
B2	Specified EQ format	EQ format
B3	Copy audio from SD card to SPI FLASH	None
B4	Copy audio from U disk to SPI FLASH	None
B8	Specified user area (config data) logging data	Address, data
B9	Into sleep mode—low consumption	None
BA	End return code	Whether need feedback information
D2	Switch the current work drive letter	Work drive letter

### Communication Query Command

CMD	Corresponding Function	Parameter
C1	Query current volume setting	C1 XX
C2	Query current working status	C2 XX
C3	Query the total number of music files in SPI FLASH	C3 XXXX
C4	Query the total number of music files in specified folder of SPI FLASH	C4 XXXX
C5	Query the total number of music files in SD card	C5 XXXXX
C6	Query the total number of music files in specified folder of SD card	C6 XXXX
C7	Query the total number of music files in U disk	C7 XXXX
C8	Query the total number of music files in specified folder of U disk	C8 XXXX
C9	Query audio file currently playing	C9 XXXX
CA	Query current external connection status	CA XX
CB	Query the song name currently playing	CB XX(8 digit)
CD	Query specified MP3 special identifying data	CD xx(8 digit)
CF	Query user cache data of the specified address	CF xxxxxx

## 6.2.3 Write operation command

### 6.2.3.1. Write operation command return code format

Operation Code
XX

Note: after finishing executing write command, return the corresponding one-byte operation code.

Return code: 00 means OK, execute command.

01 means FAIL, command error, not execute.

02 means EMP, no such file.

### 6.2.3.2. Specified SPI FLASH root directory index play (A0)

This command can play the voice file of SPI FLASH. The file ordered by index.

Start Code	Length	Command	High order of audio	Low order of audio	Check code	End code
7E	05	A0	00	01	XX	EF

Note: If the specified song does not exist, it will not influence current playing when specified to play.

### 6.2.3.3 Specified file play in SPI FLASH folder (A1)

This command is used for classifying music in the form of folder when copy from U disk and SD card to SPI-FLASH.

Start Code	Length	Command	Folder	High order of audio	Low order of audio	Check Code	End Code
7E	06	A1	01	00	02	XX	EF

Above command, "01" in folder column means No.1 file. "00 02" stands for the second song in song column. This command specifies to play the second audio file of No.1 folder.

### 6.2.3.4 Specified SD card root directory index play (A2)

This command can play specified file in SD card, influenced by file store sequence. File order is according to the index order.

Start Code	Length	Command	High order of audio	Low order of audio	Check Code	End Code
7E	05	A2	00	01	XX	EF

Note: If specified song does not exist, it will not influence playing when specified to play.

### 6.2.3.5 Specified file name play in SD card (A3) (File name 8 characters at most)

This command can according to file name play audio in specified root directory of SD card.(File name no more than 8 characters)

Start Code	Length	Command	File Name (high-low)			Check Code	End Code	
7E	07	A3	54('T')	30('0')	30('0')	32('2')	XX	EF



“54, 30, 30, 32” respectively stand for ASCII code of T002. Only file name is ASCII code value, other data are hexadecimal values. The above commands mean playing audio file “T002XXX.MP3”. And the first four digits need to be corresponding.

### 6.2.3.6 Specified file index play in SD card folder (A4)

This command can play the audio file of folder in specified root directory.(File name is fixed 5 characters)

Start Code	Length	Command	Folder Name (High-Low)					Folder Index(High-Low)		Check Code	End Code
7E	0A	A4	'M'	'U'	'S'	'I'	'C'	00	01	XX	EF

File name is ASCII code value; other data are hexadecimal values. The above commands mean playing the second audio file of folder “MUSIC” in the specified root directory (index number is 0001).

### 6.2.3.7 Specified folder name play in SD card folder (A5)

This command is according to the file name to play in specified root directory(folder name is fixed 5 characters, the length of file name is 8 characters at most)

Start Code	Length	Command	Folder Name (High-Low)					File Name(High-Low)				Check Code	End Code				
7E	0C	A5	'M'	'U'	'S'	'I'	'C'	54	30	30	32	'T'	'0'	'0'	'2'	XX	EF

“54, 30, 30, 32” respectively stand for ASCII code of T002. Only file name is ASCII code value; other data are hexadecimal values. The above commands mean playing the audio file “T002XXX.MP3”. And the first four digits need to be corresponding.

### 6.2.3.8 Specified U disk root directory index play (A6)

This command can play the specified file of U disk, but influenced by file order. The order is according to index order.

Start Code	Length	Command	High order of audio	Low order of audio	Check Code	End Code
7E	05	A6	00	01	XX	EF

Note: If specified audio is not existed, it will not affect current playing.

### 6.2.3.9 Specified U disk file name play (A7)

This command can play audio in specified root directory of U disk according to the file name.

Start Code	Length	Command	File Name (High-Low)				Check Code	End Code
7E	07	A7	54('T'	30('0')	30('0')	32('2')	XX	EF

“54, 30, 30, 32” respectively stand for ASCII code of T002. Only file name is ASCII code value; other data



are hexadecimal values. The above commands mean playing the audio file "T002XXX.MP3". And the first four digits need to be corresponding.

### 6.2.3.10 Specified file index play in U disk folder (A8)

This command can play audio according to file index in folder of specified root directory.(File name is fixed 5 characters)

Start Code	Length	Command	Folder Name (High-Low)					File Name(High-Low)		Check Code	End Code
7E	0A	A8	'M'	'U'	'S'	'I'	'C'	00	01	XX	EF

File name is ASCII code value; other data are hexadecimal values. The above commands mean playing the second audio file of folder "MUSIC" in the specified root directory (index number is 0001).

### 6.2.3.11 Specified file index play in U disk folder (A9)

This command can play audio file according to the file name in specified U disk root directory.

Start Code	Length	Command	Folder Name (High-Low)					File Name(High-Low)				Check Code	End Code
7E	0C	A9	'M'	'U'	'S'	'I'	'C'	54	30	30	32	XX	EF
								'T'	'0'	'0'	'2'		

"54, 30, 30, 32" respectively stand for ASCII code of T002. Only file name is ASCII code value; other data are hexadecimal values. The above commands mean playing the audio file "T002XXX.MP3". And the first four digits need to be corresponding.

### 6.2.3.12 Pause Command (AA)

Start Code	Length	Command	Check Code	End Code
7E	03	AA	AD	EF

In first time, sending this command, it will pause to play audio; resend data, it will continue to play audio from the pause.

### 6.2.3.13 Stop Command (AB)

Start Code	Length	Command	Check Code	End Code
7E	03	AB	AE	EF

If send this command, it will stop playing current audio.

### 6.2.3.14 Next Command (AC)

Start Code	Length	Command	Check Code	End Code
7E	03	AC	AF	EF

This command can trigger to play the next audio. When playing to the last audio, sending this command can play the first audio.

### 6.2.3.15 Previous Command (AD)

Start Code	Length	Command	Check Code	End Code
7E	03	AD	B0	EF

This command can trigger to play the previous audio. When playing the first audio, sending this command can play the last audio.

### 6.2.3.16 Volume Control Command (AE)

Volume has 32 levels, from 00 to 31, 00 is mute, 31 is the max volume.

Start Code	Length	Command	Volume Level	Check Code	End Code
7E	04	AE	1F	XX	EF

The example is the volume of 31 level. This command can modify and adjust volume in real time.

### 6.2.3.17 Specified Play Mode (AF)

Start Code	Length	Command	Parameter	Check Code	End Code
7E	04	AF	00: single play(dormant)	B3	EF
			01: single cycle	B4	
			02: all audio cycle play	B5	
			03: random mode	B6	

Note: this command modifies the playing mode in the condition of no power down. After power down it will restore the default mode. When using this command, just set MCU once in the module initialization, then it will execute in this way each time when powered on.

### 6.2.3.18 Combination Play Command (B0)

This command can continue playing some files in specified current directory. This command is only used for index play.

Start Code	Length	Command	Mark Word	Check Code	End Code
7E	04	B0	01	XX	EF

Start Code	Length	Command	High order of audio	Low order of audio	Check Code	End Code
7E	05	B0	00	01	XX	EF

Start Code	Length	Command	Mark Word	Check Code	End Code
7E	04	B0	FF	XX	EF

Combination play means that continue sending 10 or less music group code to WT2000. WT2000 plays audio in turn, according to the sequence of receiving code. The difference from directly sending file name to control music play is that before finishing playing music, send the next code, it will not be interrupted. After receiving command, it will do FIFO processing.

For example: When WT2000 continues receiving seven groups of data "7E 04 B0 01 B5 EF", "7E 05 B0 00 01 B8 EF", "7E 05 B0 00 02 B9 EF", "7E 05 B0 00 03 BA EF", "7E 05 B0 00 04 BB EF", "7E 05 B0 00 05 BC EF", "7E 04 B0 FF B3 EF", it will specify to play the first, second, third, fourth, fifth audio file in SD card. 7E 04 B0 01 B5 EF is start code, 7E 04 B0 FF B3 EF is end code.

**Note:**

1. Before combination play, if want to play file in other storage, you must first send specified storage play command (that is, mark word of start code), then send the latter audio command to realize combination play or directly switch mode.

**Mark word:**→00 stands for inserting the specified index address in SPI-FLASH.

→01 stands for inserting the specified index address in SD card.

→02 stands for inserting the specified index address in U disk.

2. For continuous combination play, support 10 groups at most. During playing, if there is new play command, it will be interrupted and execute new command.

**Note:**

1. Timeout judgment: for example: if only send the code 7E 04 B0 01 XX EF, after code receiving is finished, start timing; if timekeeping over 3s with no response, need to delete relative information.

2. After sending 7E 04 B0 01 XX EF, if receiving 7E 06 B0 01 00 01 XX EF and other command, delete the recorded time and re-timing again until exceeding 10 groups, or receiving the end code or waiting more than 3s. If start code and address code are received, but end code is not received, after overtime or over 10 commands, it will directly start to play audio according the command. In other words, if the address code of combination play has been sent, even the timer expires, it will not directly empty out all, but start to play the received data.

3. During combination playing, sending other command will interrupt the play.

**6.2.3.19 Inter-cut Command (B1)**

Start Code	Length	Command	Mark Word	High order of audio	Low order of audio	Check Code	End Code
7E	06	B1	01	00	01	XX	EF

Note: When receive this command, it will pause current playing and play the audio specified by this command. After finishing playing, it will continue to play the paused audio (can have error within 1s or round numbers of second)

When first time inner-cut play isn't finished, send the second inter-cut command, the command is invalid. After the first inner-cut is finished, it can have the second inter-cut play. It supports inter-cut between the same devices or different devices.

**Mark word:**→00 stands for inserting the specified index address in SPI-FLASH.

→01 stands for inserting the specified index address in SD card.

→02 stands for inserting the specified index address in U disk.

**6.2.3.20 Specified EQ Mode (B2)**



Start Code	Length	Command	Parameter	Check Code	End Code
7E	04	B2	00: Normal (in default)	B6	EF
			01: Pop	B7	
			02: Rock	B8	
			03: Jazz	B9	
			04: Classic	BA	
			05: Base	BB	

### 6.2.3.21 Copy audio from SD card to SPI FLASH (B3)

Start Code	Length	Command	Check Code	End Code
7E	03	B3	B6	EF

Note: indicator light will flash when copy. After finishing, indicator light will stop flashing.

MP3 file copy correct, config data copy correct, return 00

MP3 file copy correct, config data copy abnormal, return 01

MP3 file copy abnormal, config data copy correct, return 02

MP3 file copy abnormal, config data copy abnormal, return 03

### 6.2.3.22 Copy audio from U disk to SPI FLASH (B4)

Start Code	Length	Command	Check Code	End Code
7E	03	B4	B7	EF

Note: indicator light will flash when copy. After finishing copying, indicator light will stop flashing.

MP3 file copy correct, config data copy correct, return: 00

MP3 file copy correct, config data copy abnormal, return: 01

MP3 file copy abnormal, config data copy correct, return: 02

MP3 file copy abnormal, config data copy abnormal, return: 03

### 6.2.3.23 Specified user area (config data) logging data (B8)

Store data in specified address (0000H-0FFFH), max 4K address; store 200 characters at most one time.

Start Code	Length	Command	Start Address (0000H-0FFFH)	Data Area (At most 200B)	Check Code	End Code
7E	09	B8	00 00	F1 E2 D3 04	DA	EF

Check code: from start address, data will be summation (hexadecimal), until the low byte data of the total sum in data area. For example, the above command  $0X00+0X00+0XF1+0XE2+0XD3+0X04 = 0X02DA$ , so the check code is 0XDA.

Above command means, through WT2000 user writes 0XF1, 0XE2, 0XD3, 0X04 into the SPI-FLASH address of 4000H, 4001H, 4002H, 4003H.

### 6.2.3.24 End return code(BA)

Start Code	Length	Command	Parameter	Check Code	End Code
7E	04	BA	00: not need to return information ( in default)	BE	EF
			01: need to return information	BF	

This command will decide whether need to return information after finishing every audio play, stand for current audio position. Return format: EF XX XX (return audio index position (two characters). If the audio is in folder, it will return the index position in folder)

### 6.2.3.25 Switch the current work drive letter (D2)

Start code	Length	Command	Parameter	Check code	End code
7E	04	D2	00: internal memory	D6	EF
			01: SD card(default)	D7	
			02: U disk	D8	

## 6.2.4 Read operation command

### 6.2.4.1 Query current volume setting (C1)

Start Code	Length	Command	Check Code	End Code
7E	03	C1	C4	EF

Return Format

Operation Code	Return Value
0XC1	Volume Value (00-1F)

### 6.2.4.2 Query current working status (C2)

Start Code	Length	Command	Check Code	End Code
7E	03	C2	C5	EF

Return Format

Operation Code	Return Value
0XC2	01: Play 02: Stop 03: Pause

### 6.2.4.3 Query the total number of music files in SPI FLASH (C3)

Start Code	Length	Command	Check Code	End Code
7E	03	C3	C6	EF

Return Format

Operation Code	Return Value (2BYTE)
0XC3	The total number of file

### 6.2.4.4 Query the total number of music files in specified folder of SPI FLASH (C4)

Start Code	Length	Command	Folder	Check Code	End Code
7E	04	C4	1	XX	EF

This command means, in SPI-FLASH, read the total number of audio files stored in the form of the first



folder.

#### Return Format

Operation Code	Return Value (2BYTE)
0XC4	The total number of file

#### 6.2.4.5 Query the total number of music files in SD card (C5)

Start Code	Length	Command	Check Code	End Code
7E	03	C5	C8	EF

#### Return Format

Operation Code	Return Value (2BYTE)
0XC5	The total number of file

#### 6.2.4.6 Query the total number of music files in specified folder of SD card (C6)

Start Code	Length	Command	Folder Name (High-Low)	Check Code	End Code
7E	08	C6	'M' 'U' 'S' 'I' 'C'	XX	EF

The folder name exists in ASCII code, above commands mean that read the total number of audio files of folder "MUSIC" file in root directory.

Return Format (C600 00 means no audio file or such folder)

Operation Code	Return Value(2BYTE)
0XC6	The total number of file

#### 6.2.4.7 Query the total number of music files in U disk (C7)

Start Code	Length	Command	Check Code	End Code
7E	03	C7	CA	EF

#### Return Format

Operation Code	Return Value(2BYTE)
0XC7	The total number of file

#### 6.2.4.8 Query the total number of music files in specified folder of U disk(C8)

Start Code	Length	Command	File Folder (High-Low)	Check Code	End Code
7E	08	C8	'M' 'U' 'S' 'I' 'C'	XX	EF

The folder name exists in ASCII code, above commands mean that read the total number of audio files of folder "MUSIC" file in root directory.

Return Format (C800 00 means no audio file or such folder)

Operation Code	Return Value(2BYTE)
0XC8	The total number of file

**6.2.4.9 Query audio file currently playing (C9)**

Start Code	Length	Command	Check Code	End Code
7E	03	C9	CC	EF

**Return Format**

Operation Code	Document Number High Type	Document Number Low Type
0XC9	XX	XX

**6.2.4.10 Query current external connection status (CA)**

Start Code	Length	Command	Check Code	End Code
7E	03	CA	CD	EF

**Return Format**

Operation Code	Return Value
0XCA	XX

When SD card or U disk plugs in or pulls out, WT2000 will automatically return data to prompt. Low 4BIT of return value represent the existing state of PC connection (BIT3), U disk (BIT2), SD card (BIT1) and SPI-FLASH (BIT0), respectively.

0 stands for existence

1 stands for nonexistence

For example:

0x01: without PC connection (BIT3=0), without U disk (BIT2=0), without SD card (BIT1=0), with SPI-FLASH (BIT0=1)

0x07: without PC connection (BIT3=0), without U disk (BIT2=2), without SD card (BIT1=1), with SPI-FLASH (BIT0=1)

**6.2.4.11 Query the song name currently playing (CB)**

Start Code	Length	Command	Working Mode	High order of audio	Low order of audio	Check code	End Code
7E	06	CB	01	00	01	XX	EF

**Return Format**

Operation Code	Return Value
0XCB	XX XXXXXXXXXXXXXXXX

The returned data is in ASCLL code. If the song name is not enough 8 bytes, those without 8 bytes will be supplemented with 20H to return.

**6.2.4.12 Query specified MP3 special identifying data(only for specified index)(CD)**

Start code	Length	Command	Working	High order of	Low order of	Check sum	End code
------------	--------	---------	---------	---------------	--------------	-----------	----------





			mode	audio	audio		
7E	06	CD	01	00	01	XX	EF

There are 3 working modes: 00 is SPI-FLASH mode, 01 is SD card mode, 02 is U disk mode

Return Format

Operation Code	Return Value
0XCD	XX XX XX XX XX XX XX XX

Note: When send command “7E 06 CD 01 00 01 D5 EF”, WT2000 will read the special mark data of the first music, the 8 bytes data stored in the 15H to 1CH address of MP3 file. Return code like “CB 80 81 82 83 84 85 86 87” means “80H” is stored in the 15H address of the first MP3 file. “81H” is stored in 16H address...

Reading data allows to stop playing audio file.

#### 6.4.12. Read user cache data of the specified address (CC)

Read data of Config.mp3 file in user area, SD card or U disk in SPI-FLASH.

Start Code	Length	Command	Working Drive	Start Address 0000H~0FFFH	Length of return data (at most 512)	Check sum	End Code
7E	08	CF	00	XX XX	XX XX	XX	EF

Return Format:

Return Code	Working Drive	Data Length	Data Content
0XCF	00	XX XX	XX XXXXXX

Note: XX XX is the length of specified return data. Serial command can specify to return the number of data bytes. Before reading, switch the drive first.

If the length of data in Config.mp3 file is less than the total amount of data command required, will use “FF” to replace the insufficient data. For example, in Config.mp3 file, store “OFF ON”, send read command “7E 07 CF 00 00 02 00 02 DA EF”, it will return “CF 00 00 08 4F 46 46 00 4F 4E FF FF 03 7F”. If send read data command “7E 07 CF 00 00 02 00 02 DA EF”, it will return “CF 00 00 02 46 00 00 48”. In SPI-FLASH, read user cache area (copied Config.mp3 data or data written by user through AD command), address range is 0x0000-0x0FFF.

In SD card drive, directly read data of Config.mp3 file to return.

in U disk, directly read data of Config.mp3 file to return.

Note: congfig area max support 4KB (0000H-0FFFH)



### 8.2 WT2000B03 module with external amplifier

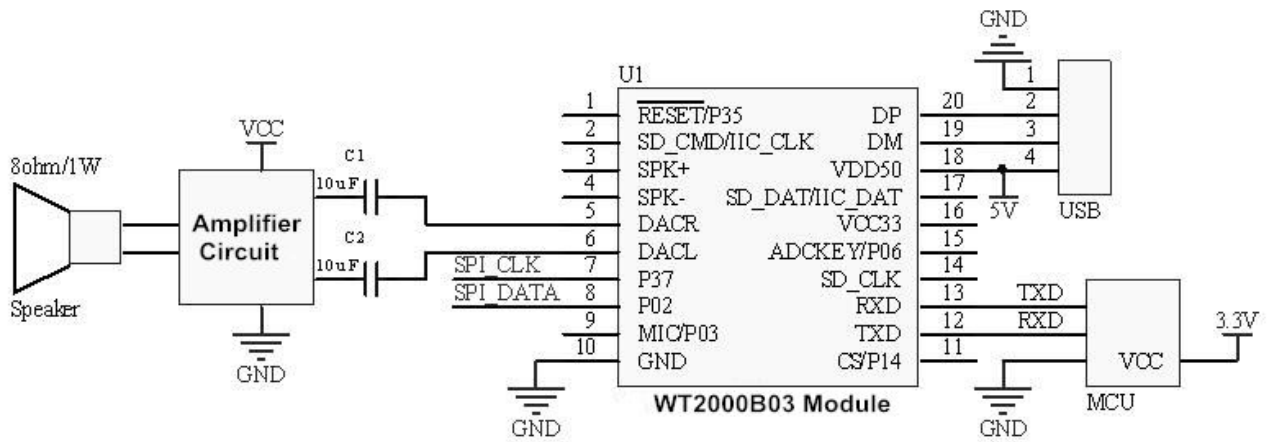

Note:

1. IO port of WT2000B03 is 3.3V level. It can directly connect with 3.3V MCU. If connected with 5V MCU, it needs to increase level shift circuit.
2. The coupling capacity of C1 and C2 is 0.1uF-10uF.