



The Manual of WT5001 Modules

- 1、 Selection Guide3
 - 1.1、 Function Table3
 - 1.2、 Absolute Maximum Rate3
 - 1.3、 Chip Electrical Parameters.....3
- 2、 Detailed Description of The Pin Assignment Diagram3
 - 2.1、 WT5001M01-16P Pin Assignment and Description3
 - 2.2、 WT5001M02-28P Pin Assignment and Description4
 - 2.3、 WT5001M03-28P Pin Assignment and Description5
 - 2.4、 WT5001M04-14P Pin Assignment and Description6
- 3、 Detailed description of the functional operation7
 - 3.1、 BUSY indicate output7
 - 3.2、 Function detail of ADC standard key mode.....7
 - 3.3、 Function setting description.....7
 - 3.3.1、 Setting method7
 - 3.3.2、 Function detail7
 - 3.3.3、 ISound.mp3 file storing location.....8
 - 3.4、 SPI FLASH copy function.....8
 - 3.4.1、 Method of mass production.....8
 - 3.4.2、 Copy method of SD card or U-disk8
 - 3.4.3、 The order of music file stored in SD card:8
 - 3.5、 Description of specific function:8
 - 3.5.1、 Press to copy function keys8
 - 3.5.2、 One to one function key8
 - 3.5.3、 A、 B mode function key8
 - 3.6、 Description of storage9
 - 3.6.1、 Stored format.....9
 - 3.6.2、 Memory power down.....9
 - 3.7、 Sleep and awake audio process function9
 - 3.8、 Process audio files9
- 4、 Serial communication control protocol9
 - 4.1、 Protocol command format9
 - 4.2、 Write instruction.....9
 - 4.2.1、 Format of code returned from writing instruction9



4.2.2、Specify the files in SD card to play	9
4.2.3、Specify the files in SPI Flash to play.....	9
4.2.4、Specify the files in U disk to play	10
4.2.5、Pause	10
4.2.6、Stop	10
4.2.7、Next song	10
4.2.8、Previous song	10
4.2.9、Volume control	10
4.2.10、Combine to play	10
4.2.11、Set playing mode.....	10
4.2.12、Instruction of copy the content from SD card to SPI FLASH.....	11
4.2.13、Instruction of copy the content from U disk to SPI FLASH.....	11
4.2.14、Instruction of insertion.....	11
4.3、Instructions of setting clock	11
4.3.1、Set data information	11
4.3.2、Set time information	11
4.3.3、Set waking up time information.....	11
4.3.4、Set information of time period.....	11
4.4、The command of reading operation	12
4.4.1、Read the current volume value.....	12
4.4.2、Read the current playing state.....	12
4.4.3、Read the total number of files in SPI Flash	12
4.4.4、Read the total number of files in SD card.....	12
4.4.5、Read the total number of files in U disk	12
4.4.6、Read the current audio file name.....	12
4.4.7、Read iSound.mp3 file “cf” character	12
4.4.8、Read the current data information	12
4.4.9、Read the current time information	13
5、Example of application circuit.....	13
5.1、WT5001M01-16P Minimum application circuit diagram	13
5.2、WT5001M02-28P Minimum application circuit diagram	13
5.3、WT5001M03-28P Minimum application circuit diagram	13
5.4、WT5001M04-14P Minimum application circuit diagram	14
6、Appendix 1: SPI-FLASH capacity corresponding parameter	14
7、Appendix 2: Module and development download tool selection	14

8、Appendix 3: Reference solution and module model selection consult..... 15
 9、Manual Version Record 16

1、 Selection Guide

1.1、 Function Table

Model	Package	Size (mm)	SPI download	RS232 Serial control	Press to copy	ADC_KEY	SD card	SD card socket	U disk	One to one key control	A、 B mode
WT5001M01-16P	16PIN module	20.9*19.6	√	√	√	√	×	×	×	×	×
WT5001M02-28P	28PIN module	36.2*19.1	√	√	√	√	√	√	√	√	×
WT5001M03-28P	28PIN module	36.1*19.7	√	√	√	√	√	×	√	×	×
WT5001M04-14P	14PIN module	20.9*19.6	√	√	√		×	×	×	×	×
WT5001-48L	TQFP48module	9.0*9.0	√	√	√	√	√	×	√	√	√

1.2、 Absolute Maximum Rate

Parameters	Mark	Enviroment condition	Rated value	Unit	Note
Supply voltage	VDD	Input	-0.3V-5.2V	V	

1.3、 Chip Electrical Parameters

Parameters	Mark	Enviroment condition	Minimum value	Typical value	Maximum value	Unit	Note
Supply voltage	VDD	RL=8Ω,1W	3.3	5	5.2	V	
Play current	Ip	RL=8Ω,1W	-	39.1	-	mA	Play mute
Pause current	Ir	RL=8Ω,1W	-	37.6	-	mA	
Stop current	Id	RL=8Ω,1W	-	37.6	-	mA	
Copy current	Ic	RL=8Ω,1W	-	42	52	mA	
Button current	Ik	RL=8Ω,1W	-	45	55.6	uA	
Audio output power	Pout	RL=8Ω,1W	-	0.132	-	W	
UART response time	To	-	-	128	-	ms	

2、 Detailed Description of The Pin Assignment Diagram

2.1、 WT5001M01-16P Pin Assignment and Description

Pin assignments as follows: (WT5001M01-16P V1.2)

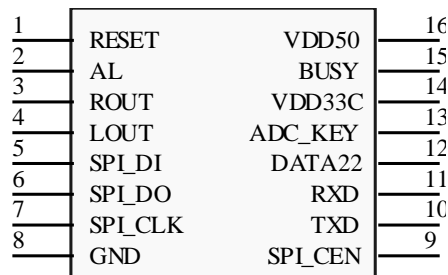

Detailed description of pin:

NUM	NAME	ATTR	DESCRIPTION	NOTE
1	RESET	I	External reset	Reset when low trigger
2	AL	ANA	ADC audio output	Can be connect to active speaker
3	ROUT	ANA	PWM audio output	Can be connect to 1W8Ωspeaker
4	LOUT	ANA	PWM audio output	Can be connect to 1W8Ωspeaker
5	SPI_DI	IO	SPI main output minor input data bus	SPI download port
6	SPI_DO	IO	SPI main input minor output data bus	SPI download port
7	SPI_CLK	IO	SPI clock bus	SPI download port
8	GND	GND	GND	
9	SPI_CEN	IO	SPI chip select bus	SPI download port
10	TXD	IO	UART send bus	
11	RXD	IO	UART receive bus	
12	DATA22		Press to copy function keys	
13	ADC_KEY	IO	ADC standard MP3 function key	
14	VCC33	PWR	LDO 3.3V output	Output 3.3V to external
15	BUSY	IO	Indication output when the module is busy	
16	VDD50	PWR	Power supply port, DC5V	

2.2、WT5001M02-28P Pin Assignment and Description

Pin assignments as follows: (WT5001M02-28P V1.4)

1	DATA16	ENABLE	28
2	GND	GND	27
3	DATA17	DP	26
4	DATA18	DM	25
5	DATA19	DATA14	24
6	DATA5	GND	23
7	RESET	VDD50	22
8	AL	BUSY	21
9	ROUT	VDD33C	20
10	LOUT	ADC_KEY	19
11	SPI_DI	DATA22	18
12	SPI_DO	RXD	17
13	SPI_CLK	TXD	16
14	GND	SPI_CEN	15

Detailed description of pin:

NUM	NAME	ATTR	DESCRIPTION	NOTE
1	DATA16	IO	One to one function key, corresponding to the address of the first song;	
2	GND		Connect to TF socket shell	
3	DATA17	IO	One to one function key, corresponding to the address of the second song;	
4	DATA18	IO	One to one function key, corresponding to the address of the third song;	
5	DATA19	IO	One to one function key, corresponding to the address of the fourth song;	
6	DATA5	IO	Control sleep and awake;when DATA5 receive 2sec high level,IC enter into sleep;when IC in sleep mode,DATA5 receive a high pulse,IC was awaken	
7	RESET	I	External reset	Low trigger to reset
8	AL	ANA	ADC audio output	Can be connect to active speaker
9	ROUT	ANA	PWM audio output	Can be connect to 1W8Ωspeaker
10	LOUT	ANA	PWM audio output	Can be connect to 1W8Ωspeaker
11	SPI_DI	IO	SPI main output minor input data bus	SPI download port
12	SPI_DO	IO	SPI main input minor output data bus	SPI download port
13	SPI_CLK	IO	SPI clock bus	SPI download port



14	GND	GND	GND	
15	SPI_CEN	IO	SPI chip select bus	SPI download port
16	TXD	IO	UART send bus	
17	RXD	IO	UART receive bus	
18	DATA22	IO	Press to copy function keys	
19	ADC_KEY	IO	ADC standard MP3 function key	
20	VDD33C	PWR	Module 3.3V output	Output 3.3V to external
21	BUSY	IO	Indication output when the module is busy	
22	VDD50	PWR	Power supply port, DC5V	
23	GND	GND	Connect to TF socket shell	
24	DATA14	IO	One to one function key ,switch play cycle mode	
25	DM	IO	USB DM differential line	
26	DP	IO	USB DP differential line	
27	GND	GND	U disk power GND,connect to TF card socket shell	
28	ENABLE	IO	Module amplifier enable pin, when vacant or keep high level, amplifier will be open; when connect to low level, amplifier will be closed	

2.3、WT5001M03-28P Pin Assignment and Description

Pin assignments as follows: (WT5001M03-28P V1.3)

1	CARD_INS	ENABLE	28
2	CARD_CLK	GND	27
3	CARD_DAT	DP	26
4	CARD_CMD	DM	25
5	VDD33	EXT_SCL	24
6	DATA5	EXT_SDL	23
7	RESET	VDD50	22
8	AL	BUSY	21
9	ROUT	VDD33C	20
10	LOUT	ADC_KEY	19
11	SPI_DI	DATA22	18
12	SPI_DO	RXD	17
13	SPI_CLK	TXD	16
14	GND	SPI_CEN	15

Detailed description of pin:

NUM	NAME	ATTR	DESCRIPTION	Note
1	CARD_INS	IO	(SD card detect pin)	
2	CARD_CLK	IO	SD/MMC/MSPRO clock bus	
3	CARD_DAT	IO	SD/MMC/MSPRO data bus	
4	CARD_CMD	IO	SD/MMC/MSPRO command bus	
5	VCC33	PWR	SD card power supply	
6	DATA5	IO	Control sleep and awake:when DATA5 receive 2sec high level,IC enter into sleep mode; when IC in sleep mode,DATA5 receive a high pulse,IC is awaken	
7	RESET	I	External reset	Low trigger to reset
8	AL	ANA	ADC audio output	Can be connect to active speaker
9	ROUT	ANA	PWM audio output	Can be connect to 1W8Ωspeaker
10	LOUT	ANA	PWM audio output	Can be connect to 1W8Ωspeaker
11	SPI_DI	IO	SPI main output minor input data bus	SPI download port
12	SPI_DO	IO	SPI main input minor output data bus	SPI download port
13	SPI_CLK	IO	SPI clock bus	SPI download port
14	GND	GND	GND	



15	SPI_CEN	IO	SPI chip select bus	SPI download port
16	TXD	IO	UART send bus	
17	RXD	IO	UART receive bus	
18	DATA22	IO	Press to copy function keys	
19	ADC_KEY	IO	ADC standard MP3 functional key	
20	VCC33	PWR	Module 3.3V output	
21	BUSY	IO	Indication output when the module is busy	
22	VDD50	PWR	Power supply port, DC5V	
23	EXT_SDL	IO	EEPROM data bus;	
24	EXT_SCL	IO	EEPROM data bus;	
25	DM	IO	USB DM differential line	
26	DP	IO	USB DP differential line	
27	GND	GND	U disk GND	
28	ENABLE	IO	Module amplifier enable pin,vacant or keep high level,amplifier will open;connect to low level ,amplifier will close	

2.4、WT5001M04-14P Pin Assignment and Description

Pin assignments as follows:

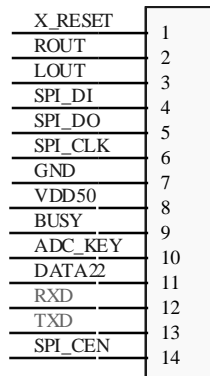

Detailed description of pin:

NUM	NAME	ATTR	DESCRIPTION	备注
1	RESET	I	External reset	Low trigger to reset
2	ROUT	ANA	PWM audio output	Directly connect to 1W 8ohms speaker
3	LOUT	ANA	PWM audio output	Directly connect to 1W 8ohms speaker
4	SPI_DI	IO	SPI main output minor input data bus	SPI download port
5	SPI_DO	IO	SPI main input minor output data bus	SPI download port
6	SPI_CLK	IO	SPI clock bus	SPI download port
7	GND	GND	GND	
8	VDD50	PWR	Power supply port, DC5V	
9	BUSY	IO	Indication output when module is busy	
10	ADC_KEY	IO	ADC standard function key	
11	DATA22		Press to copy function key	
12	RXD	IO	UART receive bus	
13	TXD	IO	UART send bus	

14	SPI_CEN	IO	SPI chip selection bus	SPI download port
----	---------	----	------------------------	-------------------

3、Detailed description of the functional operation

The below function description is for WT5001-48L, Module includes all the function of WT5001-48L,so please go to “4、Detailed Description of The Pin Assignment Diagram” to refer to module’s function .

3.1、BUSY indicate output

There is an output signal BUSY, when there are audios playing, the output will be high, and be low as normal.

3.2、Function detail of ADC standard key mode

Key	Operation	Function and operation
PLAY	Short press	Play\Pause
	Long press	Stop
NEXT	Short press	Select next song
	Long press	Fast forward (when playing)
LAST	Short press	Select previous song
	Long press	Fast reverse (when playing)
VOL+	Short press	Volume increase
	Long press	Volume increase rapidly
VOL-	Short press	Volume decrease
	Long press	Volume decrease rapidly

3.3、Function setting description

3.3.1、Setting method

There is an iSound.mp3 document in SD card .Copy all mp3 files in SD card to SPI flash to operate, while all the configurations in iSound.mp3 file is updated to the SPI flash, the specific storing location as below.

Note: you can open iSound.mp3 file on the computer by "WordPad", modify the setting parameters inside. Please don't mistake the uppercase and lowercase of the "iSound.mp3" file name.

3.3.2、Function detail

Setup as below:

sp00//,Power-on Auto Play Setting. “sp”is lowercase, “00” indicates Power-on Non Auto Play, “01” indicates Power-on Auto Play;

cl00//,Play Mode Setting. “cl” is lowercase, “00” indicates single track non cycle. “01” indicates single track cycle, “02” indicates all tracks cycle, “03” indicates play randomly;

cfxx xx xx xx//, user defined. User can read the 4 bytes through serial port command . “cf” is lowercase,the “xx” following “cf” indicates 0~F hexadecimal character, “xx”indicates one byte, there is one blank space between two bytes,such as “cf23 A0 CE 78”;

Through serial port send command “7E 02 C7 7E”, return “C7 23 A0 CE 78”(hexadecimal)

Note: Followed “cf”, can maximum write 4 bytes character size, there is no blank space between cf and the first character,but there is one blank space between two bytes; if there are less than 4 bytes after “cf”,send code, still return 5 bytes character size (includes “C7”), that means non-filled bytes was make up by “FF”, such as set up “cf23 A0 C”, return “C7 23 A0 CF FF”. Setup refer to below figure :

```

sp01//
cl02//
cf23 AD CE 78//

```

Application example:

sp to set power-on play, cl to set play mode, in the user definition data after cf , the first byte can be defined as volume, the second and third bytes defined as power-on play track, the fourth bytes set to whether sleep or not. User read definition data through serial port,and setup corresponding function according to the data .

3.3.3、ISound.mp3 file storing location

ISound.mp3 files must put at the final storing address of SD card or U disk, that is the final to deposit to the SD card or U disk (the final of index sequence).

3.4、SPI FLASH copy function

3.4.1、Method of mass production

Edit the project file by PC software, programmed into the SPI FLASH directly.

3.4.2、Copy method of SD card or U-disk

First edit iSound.mp3 file, copy it to SD card or U disk, and then copy the voice file you want to put in SD card or U disk in order, finish it; through three operating methods copy to SPI-FLASH, (default the original mode unchanged if there isn't iSound.mp3 file)

1>Press the key for 5S when power on, the red light BUSY flash that it will start to copy then release the key, red light BUSY flash until the copy ends.

2>Long press the A key and B key for 5S, the red light BUSY flash that it will start to copy then release the key, red light BUSY flash until the copy ends.

3>The MCU send serial commands to achieve copying, BUSY light indicates as the first method, when finish the copy, the serial port output an instruction, the specific instructions see agreement below.

Note: The sequence of the music files copied to the SPI-FLASH is the order of the file address stored in SD card or U disk, which is index order of the file in SD card or U disk.

3.4.3、The order of music file stored in SD card:

As the order of file address in SD card is the order of index, that is, who is the first to copy, whose memory address is at first. And the order of WT5001-48L playing music in SD card is in accordance with the order of the memory address in SD card, so be clearly that the order of the file in SD card which WT5001-48L specify to playback with, the first that you must store the file in SD card in order as planed. The following is the method to store files in SD card:

Build a file folder on your computer , to place the music files which will be stored in SD card, and make them in good order (if you want to know the files order clearly , you can add to each music file name with "0001-9999", such as 0001 the Motherland mp3, 0002 love story. mp3, rank in the order of the file, Select all the music files which will be stored in SD card, such as CTRL + A ", and then right-click the first file, select "sent to the removable storage (SD card or U disk), so the order of music files in SD card is desired.

Note: the order of music files stored in the U-disk is similar as in SD card.

3.5、Description of specific function:

3.5.1、Press to copy function keys

The normal function of the key (DATA22) is: short press, is for the next one, when play the final song, back to the first song, and the playing mode is single cycle mode; long press, is copy function when power-on , first press the key and hold before power-on, after 5S power on ,BUSY indicator flashes (said to enter the copy), release the button until the BUSY indicator stop flashing and darken, copy success.

3.5.2、One to one function key

When DATA14 is high, DATA16 \ DATA17 \ DATA18 \ DATA19 corresponds to 1, 2, 3, and 4 pieces of voice, low pulse trigger and play once then stop.

When DATA14 is low, DATA16 \ DATA17 \ DATA18 \ DATA19 correspond to 1, 2, 3, 4 pieces of voice, when low to maintain ,the playing mode is single cycle, when jump to high it will finish the current song then stop.

3.5.3、A、 B mode function key

A、 B keys are set two different operating modes: Short press A key (DATA21) to select last song, long press A key (DATA21) for 3S to set to A mode; short press B key (DATA20) to select next song, long press B key (DATA20) for 3S to set to B mode, the key is active low. When there is an EEPROM, it can remember the operating mode, identify the mode automatically when power on. As switching the mode, the light flashes indicate switching success and BUSY goes low.

Model A: auto play current song (Memory) each time when power-on, play it once and stop.

Mode B: play the next one (Memory) each time when power-on, play it once and stop; when play the final one power-on, then start to play the first one when power-on next time.

Note: when using A, B mode, there must be the EEPROM to memory power-down.

3.6、Description of storage

3.6.1、Stored format

The storage of SD card and U disk supports FAT16, FAT32 file system.

3.6.2、Memory power down

Memory store to the EEPROM when power down that is a standard function, memory power-down include volume value, the current playing song number and the setting of A, B mode referred below; when there isn't external EEPROM, it will be no memory processing when power down ,but can not affect other functions;

3.7、Sleep and awake audio process function

IC sleep and awake controlled through I/O port(DATA5), detail as below:

Sleep: when DATA5 receive 2sec high level, IC enter into sleep mode;

Awake sleep:When IC in sleep mode,when DATA5 receive a high pulse, IC was awaken

3.8、Process audio files

Support MP3, WAV format audio files. (in SPI-FLASH, do not support WAV format audio files);

If the MP3 files store in SPI-FALSH, it should be lower bit rate MP3 format files.

6Kbps~320Kbps bit rate MP3 file and 8KHz~44.1KHz sample rate WAV file

Note: Most voice quality of voice chip depend on audio itself sample rate and bit rate, WAV with more sample rate, the voice quality is better; MP3 with higher bit rate, the voice quality is better. Recommend user use COOL EDIT PRO、ADOBE AUDITION、GOLDWAVE or TTPlayer such professional audio software to convert sample rate or bit rate. Then it can be realized good performance.

4、Serial communication control protocol

Choose a available serial port, set up RS232 parameter correctly, setup as below:



Serial port: COM1 Baud rate: 9600 Check bit: Don't check Datacode: 8, End code :1

4.1、Protocol command format

Start code	Length	Opcode	Parameter	End code
0X7E	See below	See below	See below	0X7E

Note: The "length" refers to the length + opcode + the length of parameter, as follows 12.2.2 the command that specifying the file in SD card to play, of which the length is 4 bytes.

4.2、Write instruction

4.2.1、Format of code returned from writing instruction

Opcode
XX

Note: After perform each writing command, return to one byte operation code corresponded to the command.

4.2.2、Specify the files in SD card to play

This command can specify the files in SD card to play, it doesn't effect by the order of files stored.

Start code	Length	Command	High bit of songs	Low bit of songs	End code
7E	04	A0	00	01	7E

4.2.3、Specify the files in SPI Flash to play

This command can specify to the files operate only in SPI Flash.

Start code	Length	Command	High bit of songs	Low bit of songs	End code
7E	04	A1	00	01	7E

4.2.4、Specify the files in U disk to play

This command can specify the files to operate only in U disk.

Start code	Length	Command	High bit of songs	Low bit of songs	End code
7E	04	A2	00	01	7E

4.2.5、Pause

Start code	Length	Command	End code
7E	02	A3	7E

Sending the command first time to pause the music, send the data again, continue to play music from the suspension.

4.2.6、Stop

Start code	Length	Command	End code
7E	02	A4	7E

Sending the command to stop the current song.

4.2.7、Next song

Start code	Length	Command	End code
7E	02	A5	7E

The instruction trigger to play the next song, when playing the first song, sending the command can trigger to play the final music.

4.2.8、Previous song

Start code	Length	Command	End code
7E	02	A6	7E

The instruction trigger to play the previous song, when playing the final song, sending the command can trigger to play the first song.

4.2.9、Volume control

The volume levels are total of 32, from 00 to 31, which 00 is mute, 31 is maximum volume.

Start code	Length	Command	Volume level	End code
7E	03	A7	1F	7E

The command in example is to send a maximum volume 31, this instruction can adjust the volume in real time, and the volume can be in memory power-down (with EEPROM).

4.2.10、Combine to play

This command can specify certain files to play continuously in the current directory

Start code	Length	Command	High bit of songs	Low bit of songs	End code
7E	04	A8	00	01	7E

The combination of playing is sending 10 groups or less music combination code to the WT5001-48L continuously, WT5001-48L play the music according to the sequence of code received. Different from sending name to control directly is that the next code can not interrupt the playing until finish the current song , receive the command to do FIFO processing. Example : WT5001 continuously receive "7E 04 A8 00 08 7E ", "7E 04 A8 00 06 7E ", "7E A8 04 00 07 7E ", "7E A8 04 00 04 7E ", "7E 04 A8 00 03 7E ", "7E 04 A8 00 02 7E " six sets of data, WT2801-S specify to play SD files named" 0008.mp3 ", " 0006.mp3 ", " 0007.mp3 ", " 0004.mp3 ", "0003.mp3 ", " 0002.mp3 "6 audio files in order.

Note:

- A, Before the combination of playing, if you want to play other mode of files stored, you must first send the specified storage mode playing command, the track in instructions fill in the first one of the combination of playing, and then send the tracks behind in the instructions, to realize combine to play.
- B, Combination of playing only in the non-cyclic mode, is invalid in the single cycle mode or all songs cycle mode,;
- C, The continuous combination is maximum 10 groups. During playback, if there is a new command it can be interrupted, and implement the new command.

4.2.11、Set playing mode

Start code	Length	Command	Parameter	End code
7E	03	A9	00: single and no cycle (default)	7E
			01: single and cycle	
			02: all songs cycle	
			03: random play	

Note: The instruction is to modify the playing mode when power on, when power down, the mode will return to the mode which is configured in iSOUND.mp3 file. Using the instructions, it is proposal that MCU set the mode as initializing the module to realize performing as setting each time.

4.2.12、 Instruction of copy the content from SD card to SPI FLASH

Start code	Length	Command	End code
7E	03	AA	00 7E

Note: It will return "AA" immediately after receive the instruction, while the indicator flashes, if copy successfully it will return "AA 00", if not, it will return "AA 01"; the indicator stop flashing when the copy finished.

4.2.13、 Instruction of copy the content from U disk to SPI FLASH

Start code	Length	Command	End code
7E	03	AB	00 7E

Note: it will return "AB" immediately after receive the instruction, while the indicator flashes, if copy successfully it will return "AB 00", if not, it will return "AB 01"; the indicator stop flashing when the copy finished.

4.2.14、 Instruction of insertion

Start code	Length	Command	High bit of songs	Low bit of songs	End code
7E	04	AC	00	01	7E

Note: When receive the instruction, the current song will pause, and then execute this command to playback the specified song, when finish playing, it will play the original song which is pause. This instruction only can be implemented in SPI- FLASH.

4.3、 Instructions of setting clock

4.3.1、 Set data information

Start code	Length	Opcode	Year (2bytes)	Month(1byte)	Day (1byte)	End code
7E	06	B1	2011	05	08	7E

Note: The year, month, day are hexadecimal code, such as the data of 2011 is 07 DB.

4.3.2、 Set time information

Start code	Length	Opcode	Hour (1byte)	Minute (1byte)	Second(1byte)	End code
7E	05	B2	20	07	08	7E

Note: The hour, minute, second are shown as hexadecimal code.

4.3.3、 Set waking up time information

Start code	Length	Opcode	Hour (1byte)	Minute (1byte)	Second (1byte)	End code
7E	05	B3	0A	05	08	7E

Note: after executing this instruction, the clock of IC will record a time, when it's time to the setting time, DATA0 of IC will output one second pulse signal; after MCU of the controlling side detects the pulse signal from INT, sent the inquiry instruction through the serial port to read the current time, then it will know to perform what procedures this time.

4.3.4、 Set information of time period

Note: The first two bytes represent the starting time, the latter two represent the cut-off time.

Start code	Length	Opcode	Hour (1byte)	Minute (1byte)	Hour (1byte)	Minute(1byte)	End code
7E	06	B4	06	05	06	08	7E

Note: The former two bytes indicates start time, the latter bytes indicates the stop time

If there is MCU, this function can be implemented through the microcontroller, so we do not consider to performing any function.

4.3.5、 Clear the information of timing

Start code	Length	Opcode	End code
7E	02	B5	7E

4.3.6、 Clear the information of time period

Start code	Length	Command	End code
7E	02	B6	7E

4.4、The command of reading operation

4.4.1、Read the current volume value

Start code	Length	Command	End code
7E	02	C1	7E

The format returned:

Opcode	Return value
0XC1	Volume value(00-1F)

4.4.2、Read the current playing state

Start code	Length	Command	End code
7E	02	C2	7E

The format returned:

Opcode	Return value
0XC2	01: Play 02: Stop; 03: Pause

4.4.3、Read the total number of files in SPI Flash

Start code	Length	Command	End code
7E	02	C3	7E

The format returned:

Opcode	Return value
0XC3	Total number of files

4.4.4、Read the total number of files in SD card

Start code	Length	Command	End code
7E	02	C4	7E

The format returned:

Opcode	Return value
0XC4	Total number of files

4.4.5、Read the total number of files in U disk

Start code	Length	Command	End code
7E	02	C5	7E

The format returned:

Opcode	Return value
0XC5	Total number of files

4.4.6、Read the current audio file name

Start code	Length	Command	End code
7E	02	C6	7E

The format returned:

Opcode	High bit of files number	Low bit of files number
0XC6	XX	XX

4.4.7、Read iSound.mp3 file “cf” character

Start code	Length	Command	End code
7E	02	C7	7E

The format returned:

OPcode	Return value
0XC7	XX XX XX XX

Note:Return code : “C7 23 A0 CE FF”, every bit is hexadecimal character, indicates that every bit is among “0-F” ;if the “cf” in iSound.mp3 only has two or less than four bytes,then will still return four bytes character, but except for iSound.mp3 character is set, the others use “F” take place; for example “cf23 AD” , then return “C7 23 AD FF FF”.

4.4.8、Read the current data information

Start code	Length	Opcode	End code
------------	--------	--------	----------

7E	02	D1	7E
----	----	----	----

The format returned:

Opcode	Year (2bytes)	Month (1bytes)	Day (1bytes)
0XD1	XX	XX	XX

4.4.9、Read the current time information

Start code	Length	Opcode	End code
7E	02	D2	7E

The format returned:

Opcode	Hour (1bytes)	Minute (1bytes)	Second (1bytes)
0XD2	XX	XX	XX

5、Example of application circuit

5.1、WT5001M01-16P Minimum application circuit diagram

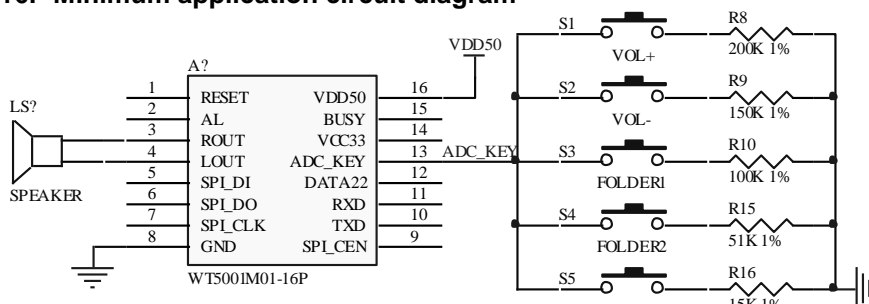

5.2、WT5001M02-28P Minimum application circuit diagram

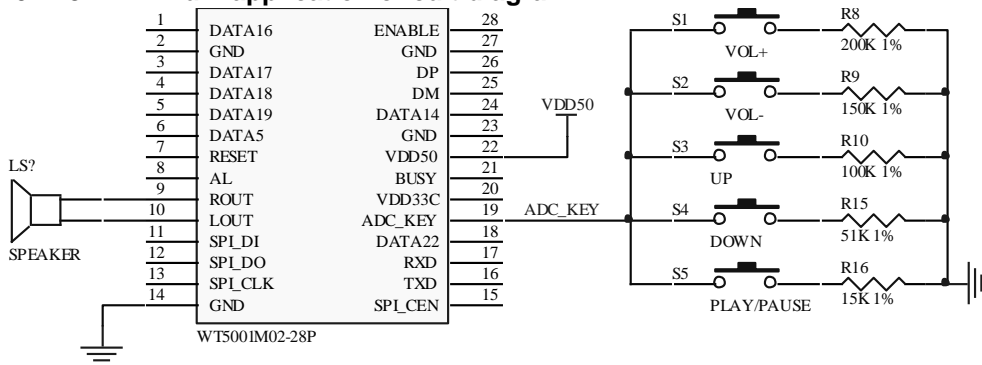

5.3、WT5001M03-28P Minimum application circuit diagram

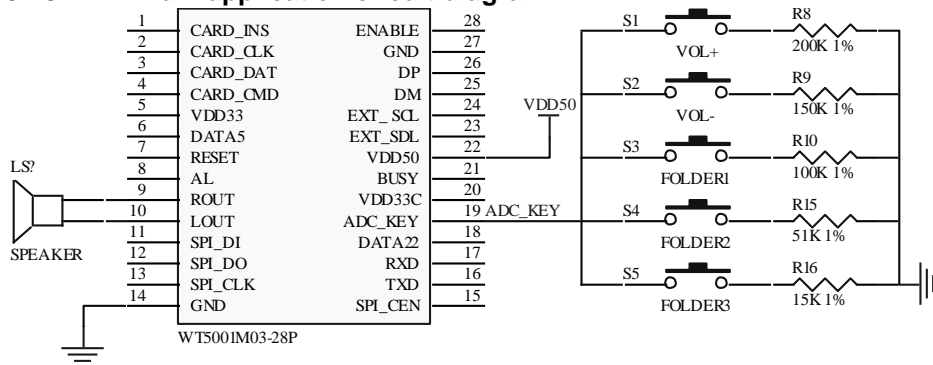

5.4、WT5001M04-14P Minimum application circuit diagram

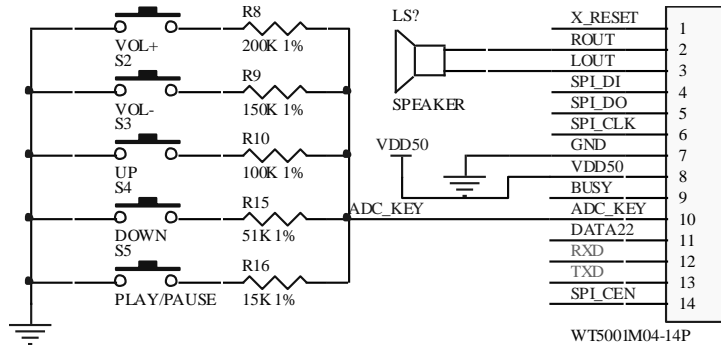

6、Appendix 1: SPI-FLASH capacity corresponding parameter

Attached list 1-1 WT5001 module FLASH capacity and time swap table(unit:s)

Capacity / Bit rate	4MBits	8MBits	16MBits	32MBits	64MBits
16Kbps	252	505	1011	2022	4045
24Kbps	163	327	654	1309	2618
32Kbps	113	226	453	906	1812
64Kbps	59	119	239	477	955
96Kbps	41	81	162	325	651
128Kbps	31	61	123	246	493
160Kbps	24	49	97	194	389
192Kbps	20	40	81	161	323
256Kbps	15	30	60	120	241
320Kbps	11	23	47	95	191







Attached list 1-2 Time of copy SD card content and FLASH capacity comparison table(unit:s)

SPI-FLASH capacity	4MBits	8 MBits	16 MBits	32 MBits	64 MBits
Time of copy SD card content	4.8	7.37	16.5	22.5	37.9

7、Appendix 2: Module and development download tool selection

Attached list 2-1 WT5001 module and development download tool selection

Model	Plug in style and appearance	Basic performance	Application characteristic	Image
-------	------------------------------	-------------------	----------------------------	-------

	(mm)			
WT5001M01-16P	16P, in-line package 19.5*21.1	1.With 1W amplifier 、 SPI-FLASH; 2.Supply voltage: 3.3V-5.0V; 3.RS232 serial port control、 ADC_KEY key、 press to copy key (long press nonsupport) ;	1.Small size; 2.Easy operation; 3.Update FLASH content need to cooperate with WT8209P01-USB downloader and WT5023P12 test board	
WT5001M02-28P	28P, in-line package 21.6*36.9	1.With 1W amplifier 、 SPI-FLASH; 2.Supply voltage:3.3V-5.0V; 3.RS232 serial port control、 ADC_KEY key、 press to copy function; 4.With SD socket、 U-disk pin、 one to one function key;	1.Free and flexible to change audio; 2.Mutiple function; 3.Come with TF socket , easy application;	
WT5001M03-28P	28P, in-line package 18.6*36.4	1.With 1W amplifier 、 SPI-FLASH; 2.Supply volage:3.3V-5.0V; 3.RS232 serial port control、 ADC_KEY key、 press to copy key; 4.With SD card pin、 U-disk pin、 EEPROM pin;	1.Free and flexible to change sound file (But need conect external SD card or U-disk) ; 2.Mutiple function; 3.With EEPROM, Support power-off memory function;	
WT5001M04-14P	14p, verical insert mode or contact edge on module 39.7*26.1	1.With 1W amplifer 、 SPI-FLASH; 2.Supply voltage:3.3V-5.0V; 3.RS232 serial port control、 ADC_KEY key、 press to copy (long press nonsupport) ;	1.Contact edge on module and vertical insert mode; 2.Easy operation; 3.Change FLASH content need to cooperate with WT8209P01-USB offline downloader and WT5023P12 test board;	
WT8209P01-USB offline downloader	USB、 in-line package 26*27	1.Downlad sound file to TF card from computer ; 2.Read TF card sound file via USB interface; 3.Can connect with WT5001 test board,download TF card content to WT5001 module; 4.Test WT5001M03-28P module, can connect external TF card socket;	1.Can act as TF card reader; 2.Work with WT5023P12 test board to update FLASH content of WT5001 module;	
WT5023P12 test board	USB、 RS232 85*101.9	1.Can test all the function of each kind of WT5001 module; 2.Cooperate with WT5001 offline downloader to change FLASH content of WT5001 module; 3.Connect external DC9 power supply.	1.Test all function of all kinds of WT5001 module; 2.Download and update FLASH content of WT5001 module;	

8、 Appendix 3: Reference solution and module model selection consult

Attached list 3-1 Reference application solution and module model selection consult



	Solution description	Basic requirement	Available component model selection	Remark
Reference solution NO.1	Intelligent toy;	With amplifier, speaker; Button control; High voice quality; No need change audio;	WT5001M01-16P 、 WT5001M02-28P 、 WT5001M03-28P 、 WT5001M04-14P 、 WT8209P01-USB offline downloader (production use) 、 WT5023P12 test board (production use)	For reference only
Reference solution NO.2	Voice advertisement machine;	With amplifier, speaker; Flexible to update audio; Some key control; High voice quality;	WT5001M02-28P、 WT5001M03-28P、 WT5023P12 test board (development and test use)	For reference only
Reference solution NO.3	Voice prompts	Can take amplifier and speaker; Flexible to update audio; Some control I/O port; High voice quality;	WT5001M02-28P 、 WT5001M03-28P 、 WT8209P01-USB offline downloader、 WT5023P12 test board (development and test use)	For reference only
Reference solution NO.4	Electronic voice greeting card;	With amplifier and speaker; Small thickness; Play simple audio; no need update voice; High voice quality;	WT5001M04-14P、 WT8209P01-USB offline downloader (production use) 、 WT5023P12 test board (production and test use)	For reference only

9. Manual Version Record

Version	Date	Description
V1.0	2011-12-13	Original version
V1.1	2011-12-22	Add appendix: SPI-FLASH capacity reference parameter
V1.2	2012-02-14	1、 Add WT5001M04-14P"pin assignment description"and application circuit; 2、 Add RS232 parameter setting; 3、 Modify"6.3.1 set data information"and"6.3.2 set time information"command description; 4、 Add WT5001-48L voice chip minimum application circuit diagram (master control) ; 5、 Modify"5.7 Process audio files"description; 6、 Add"Appendix 2: module and development download tool model selection"and"Appendix 3: reference solution and module model selection reference"description.
V1.3	2012-03-13	1、 In iSoud.mp3 setting,add "cf"character information setting; 2、 Add read"cf"character information serial command"7E 02 C7 7E "; 3、 Add sleep and awake function; Through DATA5 control; 4、 Modify module pin definition, change pin"6"and"28" of WT5001M02 and WT5001M03 to "DATA5" and"ENABLE"; 5、 Modify corresponding application circuit.