

**WT51F104**  
**1T 8052 Micro-controller**  
**with ADC Function (FLASH)**

**Data Sheet**

**Rev. 3.0**

**December 2014**

**Copyright Notice**

This data sheet is copyrighted by Weltrend Semiconductor, Inc. Do not reproduce, transform to any other format, or send/transmit any part of this documentation without the express written permission of Weltrend Semiconductor, Inc.

**Disclaimers**

**Right to make change –**

This document provides technical information for user. Weltrend Semiconductor, Inc. reserves the right to make change without further notice to any products herein.

## Table of Contents

<b>1. General Description .....</b>	<b>3</b>
<b>2. Features .....</b>	<b>3</b>
<b>3. Block Diagram .....</b>	<b>4</b>
3.1 System Clock Tree.....	5
<b>4. Pin Configuration .....</b>	<b>6</b>
4.1 Pin Description.....	8
4.2 Pin Summary .....	11
4.3 Port Structure.....	13
<b>5. Normal Function.....</b>	<b>16</b>
5.1 CPU .....	16
5.2 RAM.....	16
5.3 Flash Memory .....	17
5.4 Memory Mapping .....	18
5.5 In-System Programming (ISP) (Important!!! Must Read!!!) .....	22
5.6 Timer/Counter .....	25
5.7 Reset .....	29
5.8 System Clock and Clock sources.....	30
<b>6. Enhanced Function .....</b>	<b>31</b>
6.1 External Special Function Register (XFR).....	31
6.2 I/O Port .....	36
6.3 Interrupt .....	49
6.4 Universal Asynchronous Receiver-Transmitter (UART) .....	61
6.5 External Interrupt Request (IRQ).....	66
6.6 Pulse Width Modulation (PWM).....	70
6.7 Power Management .....	76
6.8 12 MHz RC Oscillator Calibration.....	90
6.9 Watchdog Timer and Watch Timer .....	93
6.10 I <sup>2</sup> C Serial Interface.....	97
6.11 Enhanced Timer/Counter.....	102
6.12 Serial Peripheral Interface (SPI).....	107
6.13 Analog/Digital Converter (ADC).....	113
6.14 Comparator.....	119
6.15 Low Voltage Detection (LVD).....	123
6.16 Low Voltage Detection Reset (LVDR).....	124
6.17 Emulated E <sup>2</sup> PROM .....	126
6.18 Code Option.....	130
6.19 Read Out Protection & Encryption.....	139

<b>7. Electrical Characteristics</b> .....	<b>140</b>
7.1 Absolute Maximum Ratings.....	140
7.2 Recommended Operating Parameters.....	140
7.3 DC Electrical Characteristics ( $V_{DD} = 1.8V \sim 5V, -40^{\circ}C \sim +85^{\circ}C$ ).....	141
7.4 AC Electrical Characteristics ( $T_A = 25^{\circ}C$ ).....	142
7.5 Internal 12 MHz RC Oscillator Temperature Tolerance table.....	143
7.6 A/D Converting Characteristics ( $T_A = 25^{\circ}C$ ).....	144
7.7 Bandgap Electrical Characteristic.....	145
7.8 Low Voltage Reset (LVR), Low Voltage Detection (LVD) & Low Voltage Detection Reset (LVDR) Electrical Characteristics ( $T_A = 25^{\circ}C$ ).....	145
7.9 Comparator Characteristics ( $V_{DD} = 5V, T_A = 25^{\circ}C$ ).....	145
7.10 Thermal Resistance Notice.....	146
<b>8. Application Circuits</b> .....	<b>147</b>
8.1 Power Supply.....	147
8.2 Oscillator Circuits.....	147
8.3 RESET Circuit.....	148
8.4 Standard Circuit.....	149
8.5 Development board circuits (16*2 LCM).....	150
<b>9. Product Naming Rule</b> .....	<b>151</b>
<b>10. Ordering Information</b> .....	<b>151</b>
<b>11. Pad Diagram &amp; Location Table</b> .....	<b>152</b>
<b>12. Package Dimension</b> .....	<b>154</b>
12.1 20-Pin SSOP.....	154
12.2 14-Pin SOP.....	155
12.3 10-Pin MSOP.....	156
12.4 8-Pin SOP.....	157
<b>13. Development Tools</b> .....	<b>158</b>
<b>14. Revision History</b> .....	<b>162</b>
<b>Appendix: Errata</b> .....	<b>163</b>

## 1. General Description

The WT51F104 is a general-purpose single chip Microcontroller provided by Weltrend, a well-known IC Design House in Taiwan. In addition to using the advanced IT 8052 single-chip core, wide and low operating voltage range (1.8V ~ 5.5V), and high noise immunity, the product consists of 4Kx8 Flash Program Memory, 256x8 RAM, abundant peripheral resources and versatile power management (refer to the content for more details).

The above features make the WT51F104 suitable for a wide range of applications, especially in areas such as home appliances, cooling fan, electronic ballast, car alarm, ultrasonic parking assistant sensors, and so on. The WT51F104 is a low cost high performance product with kinds of package to replace the mainstream products on the market (refer to “WT51F104 Application Notes” for more details). In order to contribute more competitive ability, Weltrend also provides wafer and dice sale for the customer.

## 2. Features

WT51F104 is an advanced 8052 Micro-controller, and it also provides the following features.

- 1T 8052 core, MCS-51 instruction set compatible
- Instruction execution time: Min. = 41.67ns @24 MHz
- 256 Bytes of RAM (256 Bytes of standard 8052 internal Data RAM)
- 4K Bytes of flash memory for program storage
- Supporting Internal & External Clock Oscillators:
  - ◆ Internal clock: 12 MHz RC oscillator or 32 kHz RC oscillator
  - ◆ External clock: 32.768 kHz ~ 24 MHz Crystal Oscillator
- Dual 16-bit Data Pointers (DPTR0 & DPTR1)
- Two 16-bit Timer/Counters (Timer0, Timer1)
- One Watchdog Timer (WDT)
- One Watch Timer
- One 16-bit Enhanced Timer with Capture function
- One UART (UART0), supports baud rate 1200 bps ~ 230400 bps (at 12 MHz)
- Emulated E<sup>2</sup>PROM
- One Master/slave SPI interface
- One Master/slave I<sup>2</sup>C interface
- Two 16-bit PWMs (PWM0, PWM1) with four outputs
- 16-channel 10-bit Analog/Digital Converter (ADC0 ~ ADC15) with Voltage Reference source
- One Comparator with 32-level Voltage Reference sources
- Three power-saving modes: Sleep mode, Green mode and Idle mode
- 16 external Interrupt IRQ pins (IRQ0 ~ IRQ15)
- 18 programmable bi-directional I/O pins, 5 of them with both high current sink/source ability (10mA)
- Low Voltage Detection (LVD) and Low Voltage Detection Reset (LVDR), both of them are programmable
- On-chip Power On Reset (POR) and Low Voltage Reset (LVR)
- Built-in Single-Wire In-Circuit Emulator (ICE) and In-System Program (ISP)
- Read Out Protection and Code Encryption
- Operating voltage range: 1.8V ~ 5.5V
- Operating temperature: -40°C ~ +85°C
- Package (**Green Package**): SOP8 (150 mil), SOP14 (150 mil), MSOP10 (118 mil), SSOP20 (150 mil)

### 3. Block Diagram

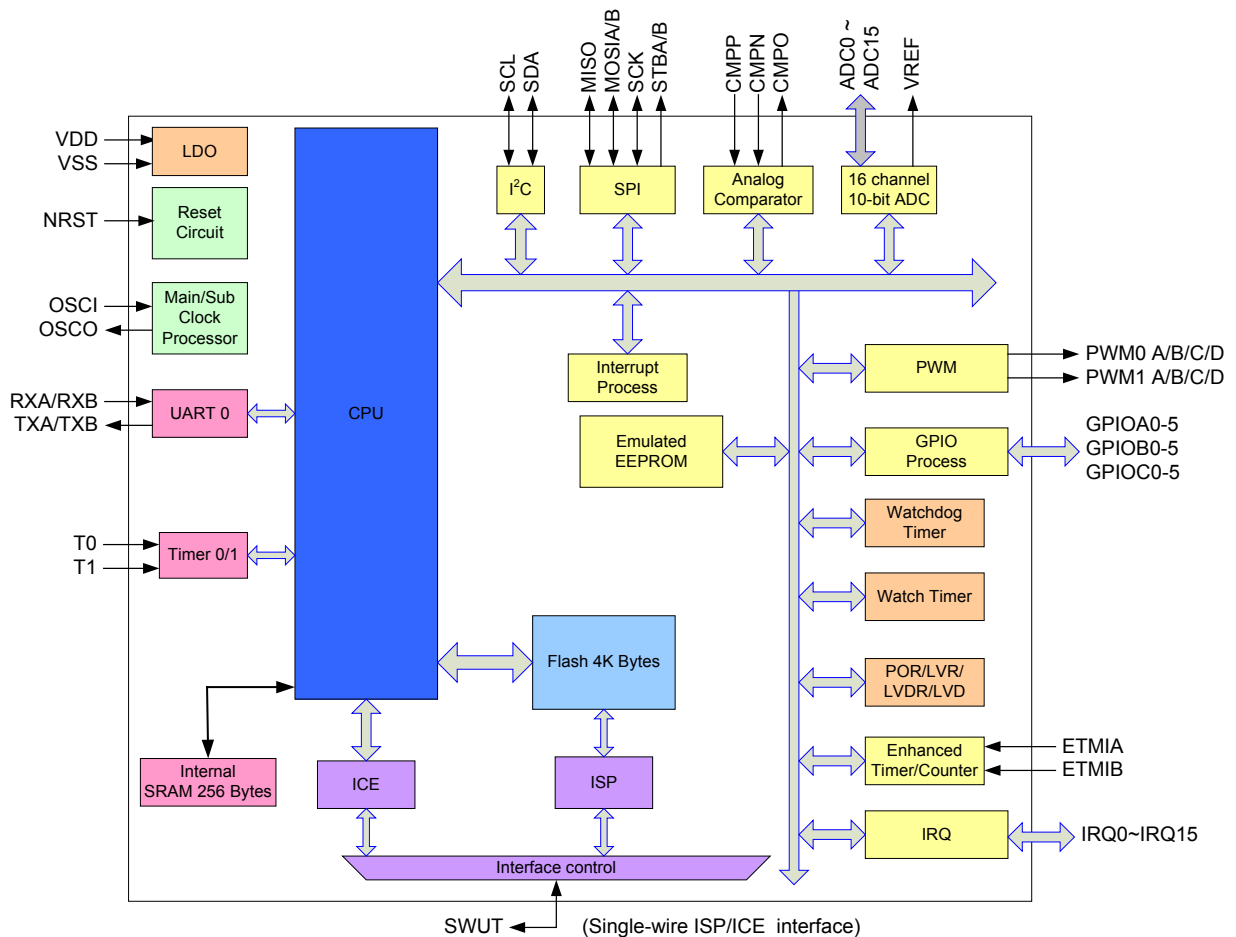

### 3.1 System Clock Tree

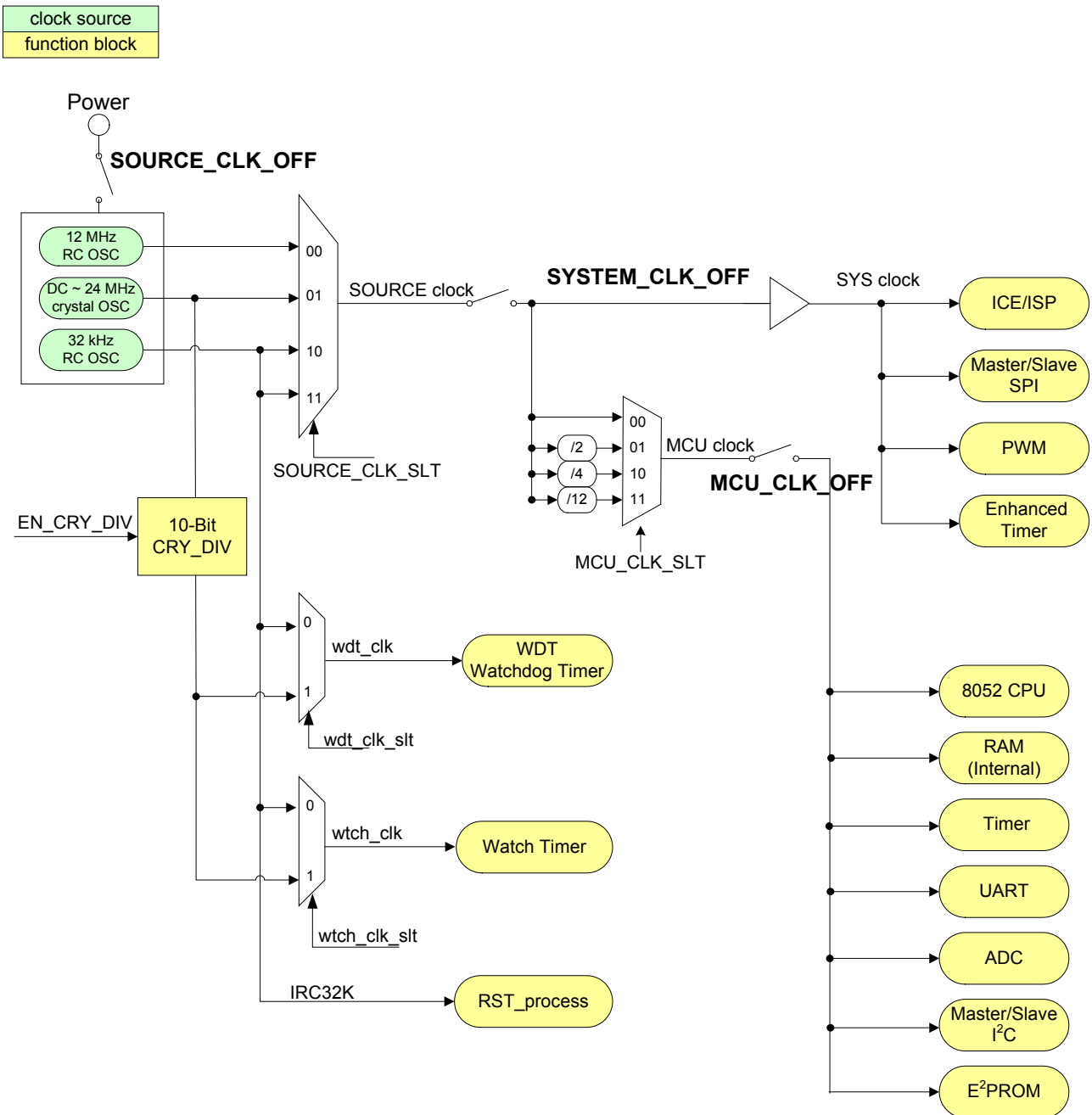

\* When using the external Crystal Oscillator, please select the corresponding driving ability according to its frequency. Refer to Oscillator Driver Control Register (XFR: 0x08) CRY\_12M\_DR[1:0] bit for more details.

## 4. Pin Configuration

### WT51F104-OG20AWT 20-Pin SSOP

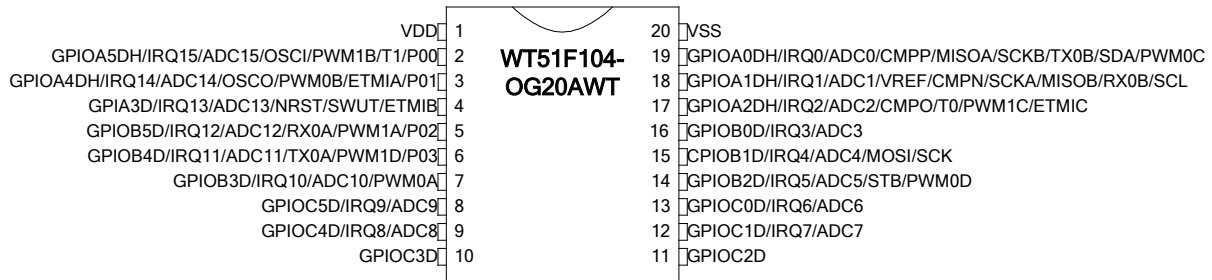

### WT51F104-SG140WT 14-Pin SOP (pins can replace Microchip PIC16F616/676/630)

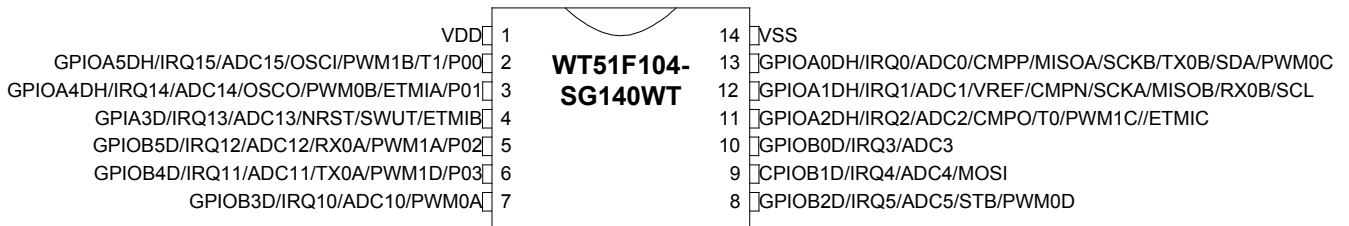

### WT51F104-MG10A WT 10-Pin MSOP

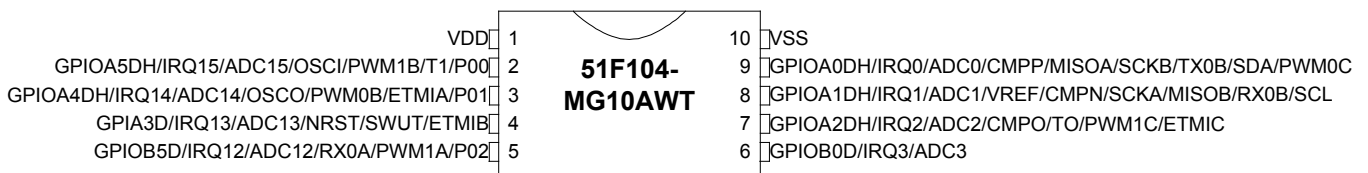

**WT51F104-SG080WT 8-Pin SOP (pins can replace Microchip PIC12F615/675/629)**

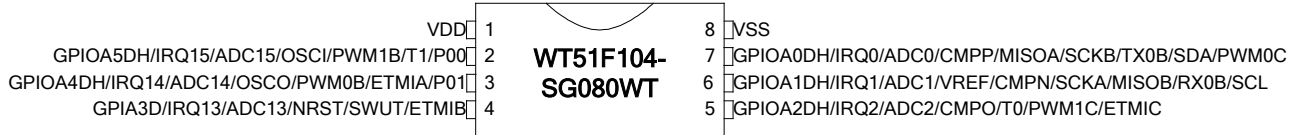



## 4.1 Pin Description

Pin Number				Pin Name		Primary Functions	
OG20A WT	SG140 WT	MG10A WT	SG080 WT		I/O	Descriptions	Circuit Type
1	1	1	1	VDD	PWR	VDD power	
2	2	2	2	GPIOA5DH/ IRQ15/ ADC15/ OSCI/ PWM1B/ T1/ P00	I/O	GPIOA5DH: General-purpose I/O with programmable high current sink/source push-pull or open drain IRQ15: External Interrupt Request 15 ADC15: Analog/Digital Converter Input 15 OSCI: External Oscillator Input PWM1B: PWM1 Output pin of Path B T1: External Output pin of Counter 1 P00: Mapping to 8052 P0.0 <b>(the mapping rGPIO_TYP must be set as open drain)</b>	B
3	3	3	3	GPIOA4DH/ IRQ14/ ADC14/ OSCO/ PWM0B/ ETMIA/ P01	I/O	GPIOA4DH: General-purpose I/O with programmable high current sink/source push-pull or open drain IRQ14: External Interrupt Request 14 ADC14: Analog/Digital Converter Input 14 OSCO: Output of External Oscillator PWM0B: PWM0 Output pin of Path B ETMIA: Enhanced Timer/Counter Clock Source or Capture Input of Path A P01: Mapping to 8052 P0.1 <b>(the mapping rGPIO_TYP must be set as open drain)</b>	B
4	4	4	4	GPIA3D/ IRQ13/ ADC13/ NRST/ SWUT/ ETMIB	I	GPIA3D: Input pin IRQ13: External Interrupt Request 13 ADC13: Analog/Digital Converter Input 13 NRST: Reset pin SWUT: Single-wire ISP/ICE interface ETMIB: Enhanced Timer/Counter Clock Source or Capture Input of Path B	D
5	5	5		GPIOB5D/ IRQ12/ ADC12/ RX0A/ PWM1A/ P02	I/O	GPIOB5D: General-purpose I/O with programmable push-pull or open drain IRQ12: External Interrupt Request 12 ADC12: Analog/Digital Converter Input 12 RX0A: UART0 Data input of Path A <b>(the mapping rGPIO_TYP must be set as open drain)</b> PWM1A: PWM1 Output pin of Path A P02: Mapping to 8052 P0.2 <b>(the mapping rGPIO_TYP must be set as open drain)</b>	C1

Pin Number				Pin Name		Primary Functions	
OG20A WT	SG140 WT	MG10A WT	SG080 WT		I/O	Descriptions	Circuit Type
6	6			GPIOB4D/ IRQ11/ ADC11/ TX0A/ PWM1D/ P03	I/O	GPIOB4D: General-purpose I/O with programmable push-pull or open drain IRQ11: External Interrupt Request 11 ADC11: Analog/Digital Converter Input 11 TX0A: UART0 Data output of Path A ( <b>the mapping rGPIO_TYP must be set as open drain</b> ) PWM1D: PWM1 Output pin of Path D P03: Mapping to 8052 P0.3 ( <b>the mapping rGPIO_TYP must be set as open drain</b> )	C1
7	7			GPIOB3D/ IRQ10/ ADC10/ PWM0A	I/O	GPIOB3D: General-purpose I/O with programmable push-pull or open drain IRQ10: External Interrupt Request 10 ADC10: Analog/Digital Converter Input 10 PWM0A: PWM0 Output pin of Path A	C1
8				GPIOC5D/ IRQ9/ ADC9	I/O	GPIOC5D: General-purpose I/O with programmable push-pull or open drain IRQ9: External Interrupt Request 9 ADC9: Analog/Digital Converter Input 9	C1
9				GPIOC4D/ IRQ8/ ADC8	I/O	GPIOC4D: General-purpose I/O with programmable push-pull or open drain IRQ8: External Interrupt Request 8 ADC8: Analog/Digital Converter Input 8	C1
10				GPIOC3D	I/O	GPIOC3D: General-purpose I/O with programmable push-pull or open drain	A
11				GPIOC2D	I/O	GPIOC2D: General-purpose I/O with programmable push-pull or open drain	A
12				GPIOC1D/ IRQ7/ ADC7	I/O	GPIOC1D: General-purpose I/O with programmable push-pull or open drain IRQ7: External Interrupt Request 7 ADC7: Analog/Digital Converter Input 7	C1
13				GPIOC0D/ IRQ6/ ADC6	I/O	GPIOC0D: General-purpose I/O with programmable push-pull or open drain IRQ6: External Interrupt Request 6 ADC6: Analog/Digital Converter Input 6	C1
14	8			GPIOB2D/ IRQ5/ ADC5/ STB/ PWM0D	I/O	GPIOB2D: General-purpose I/O with programmable push-pull or open drain IRQ5: External Interrupt Request 5 ADC5: Analog/Digital Converter Input 5 STB: STB pin of SPI PWM0D: PWM0 Output pin of Path D	C1
15	9			GPIOB1D/ IRQ4/ ADC4/ MOSI/	I/O	GPIOB1D: General-purpose I/O with programmable push-pull or open drain IRQ4: External Interrupt Request 4 ADC4: Analog/Digital Converter Input 4 MOSI: MOSI pin of SPI	C1

Pin Number				Pin Name		Primary Functions	
OG20A WT	SG140 WT	MG10A WT	SG080 WT		I/O	Descriptions	Circuit Type
16	10	6		GPIOB0D/ IRQ3/ ADC3	I/O	GPIOB0D: General-purpose I/O with programmable push-pull or open drain IRQ3: External Interrupt Request 3 ADC3: Analog/Digital Converter Input 3	C1
17	11	7	5	GPIOA2DH/ IRQ2/ ADC2/ CMPO/ T0/ PWM1C/ ETMIC	I/O	GPIOA2DH: General-purpose I/O with programmable high current sink/source push-pull or open drain IRQ2: External Interrupt Request 2 ADC2: Analog/Digital Converter Input 2 CMPO: Comparator Output pin T0: External Input pin of Counter 0 PWM1C: PWM1 Output pin of Path C ETMIC: Enhanced Timer/Counter Clock Source or Capture Input of path C	C1
18	12	8	6	GPIOA1DH/ IRQ1/ ADC1/ VREF/ CMPN/ SCKA/ MISOB/ RX0B/ SCL	I/O	GPIOA1DH: General-purpose I/O with programmable high current sink/source push-pull or open drain IRQ1: External Interrupt Request 1 ADC1: Analog/Digital Converter Input 1 VREF: Analog/Digital Converter Voltage Reference Input pin CMPN: Comparator Negative Input pin SCKA: SCK pin of Path A of SPI MISOB: MISO pin of Path B of SPI RX0B: UART0 Data input of Path B ( <b>the mapping rGPIO_TYP must be set as open drain</b> ) SCL: SCL pin of I <sup>2</sup> C	C2
19	13	9	7	GPIOA0DH/ IRQ0/ ADC0/ CMPP/ MISOA/ SCKB/ TX0B/ SDA/ PWM0C	I/O	GPIOA0DH: General-purpose I/O with programmable high current sink/source push-pull or open drain IRQ0: External Interrupt Request 0 ADC0: Analog/Digital Converter Input 0 CMPP: Comparator Positive Input pin MISOA: MISO pin of Path A of SPI SCKB: SCK pin of Path B of SPI TX0B: UART0 Data Output of Path B ( <b>the mapping rGPIO_TYP must be set as open drain</b> ) SDA: SDA pin of I <sup>2</sup> C PWM0C: PWM0 Output pin of Path C	C2
20	14	10	8	VSS	GND	Ground	

**Note 1: All I/O pins are floating on Reset status.**

**Note 2: While using 8052 port (P0.x), please set the mapping rGPIO\_TYP as open drain and connect to external pull-up resistor.**

**Note 3: While using UART0 or I<sup>2</sup>C, please set the mapping rGPIO\_TYP as open drain and connect to external pull-up resistor.**

## 4.2 Pin Summary

Explain each pin function in details.

Pin Name	Type	Description
<b>PORT</b>		
GPIOA0 ~ GPIOA5	I/O	6-bit bidirectional general-purpose I/O port (GPIA3 is input only pin)
GPIOB0 ~ GPIOB5	I/O	6-bit bidirectional general-purpose I/O port
GPIOC0 ~ GPIOC5	I/O	6-bit bidirectional general-purpose I/O port
<b>Timer 0/1</b>		
T0	I	Timer/Counter 0 External Input
T1	I	Timer/Counter 1 External Input
<b>Enhanced Timer/Counter</b>		
ETMIA	I	Enhanced Timer/Counter Clock Source or Capture Input (Path A)
ETMIB	I	Enhanced Timer/Counter Clock Source or Capture Input (Path B)
ETMIC	I	Enhanced Timer/Counter Clock Source or Capture Input (Path C)
<b>IRQ</b>		
IRQ0 ~ IRQ15	I	16 External Interrupt Request Input pins
<b>PWM</b>		
PWM0 A/B/C/D	O	PWM 0 Output of Path A / Path B / Path C / Path D
PWM1 A/B/C/D	O	PWM 1 Output of Path A / Path B / Path C / Path D
<b>UART</b>		
RX0 A/B	I	UART0 Receive Path A or Path B <b>(the mapping rGPIO_TYP must be set as open drain)</b>
TX0 A/B	O	UART0 Transmit Path A or Path B <b>(the mapping rGPIO_TYP must be set as open drain)</b>
<b>SPI</b>		
SCKA	I/O	SPI Interface Clock of Path A
MISOA	I/O	SPI Data pin MISO (Master Input; Slave Output) of Path A
SCKB	I/O	SPI Interface Clock of Path B
MISOB	I/O	SPI Data pin MISO (Master Input; Slave Output) of Path B
MOSI	I/O	SPI Data pin MOSI (Master Output; Slave Input)
STB	I/O	SPI Enable
<b>ADC</b>		
ADC0 ~ ADC15	I	16 Analog/Digital Input pins

<b>ACOMP</b>		
CMPP	I	Comparator Positive Input pin
CMPN	I	Comparator Negative Input pin
CMPO	O	Comparator Output pin
<b>I<sup>2</sup>C</b>		
SCL	I/O	I <sup>2</sup> C interface clock
SDA	I/O	I <sup>2</sup> C interface data
<b>VCC &amp; VSS</b>		
VDD	P	Power
VSS	P	Ground
OSCO	O	Main (Sub) oscillator output
OSCI	I	Main (Sub) oscillator input
NRST	I	CPU reset
<b>ISP &amp; ICE</b>		
SWUT	I/O	Single-wire ISP & ICE interface

### 4.3 Port Structure

#### I/O Structure (Type A)

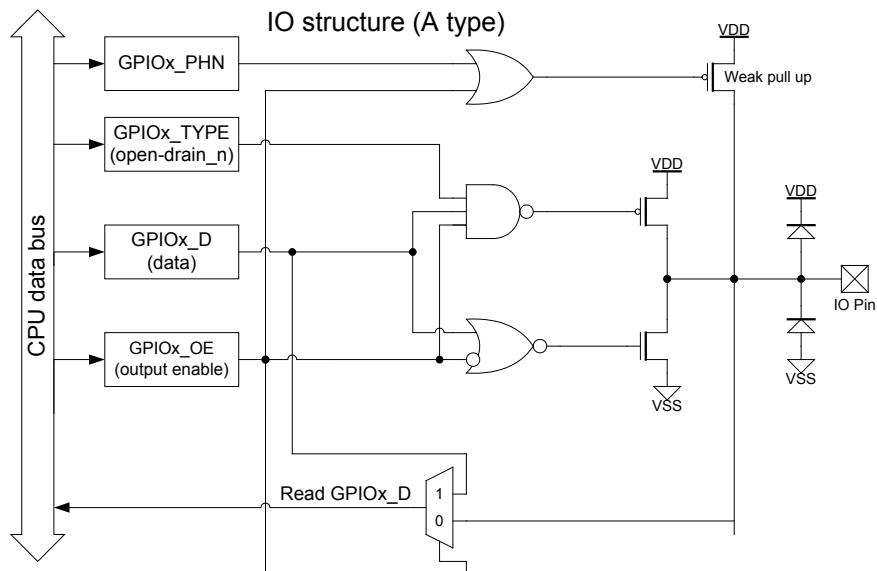

#### I/O Structure (Type D)

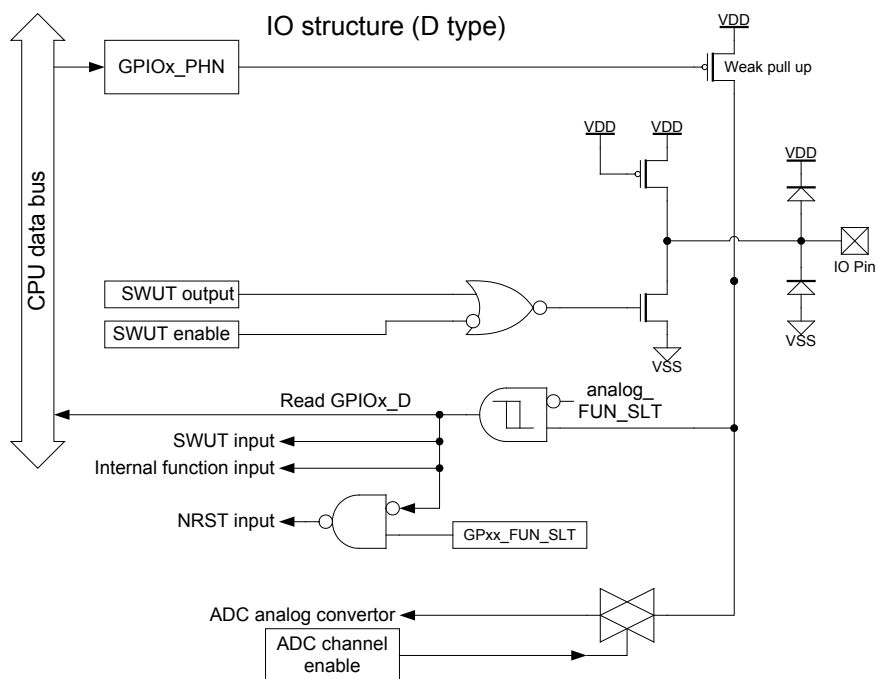

**I/O Structure (Type B)**

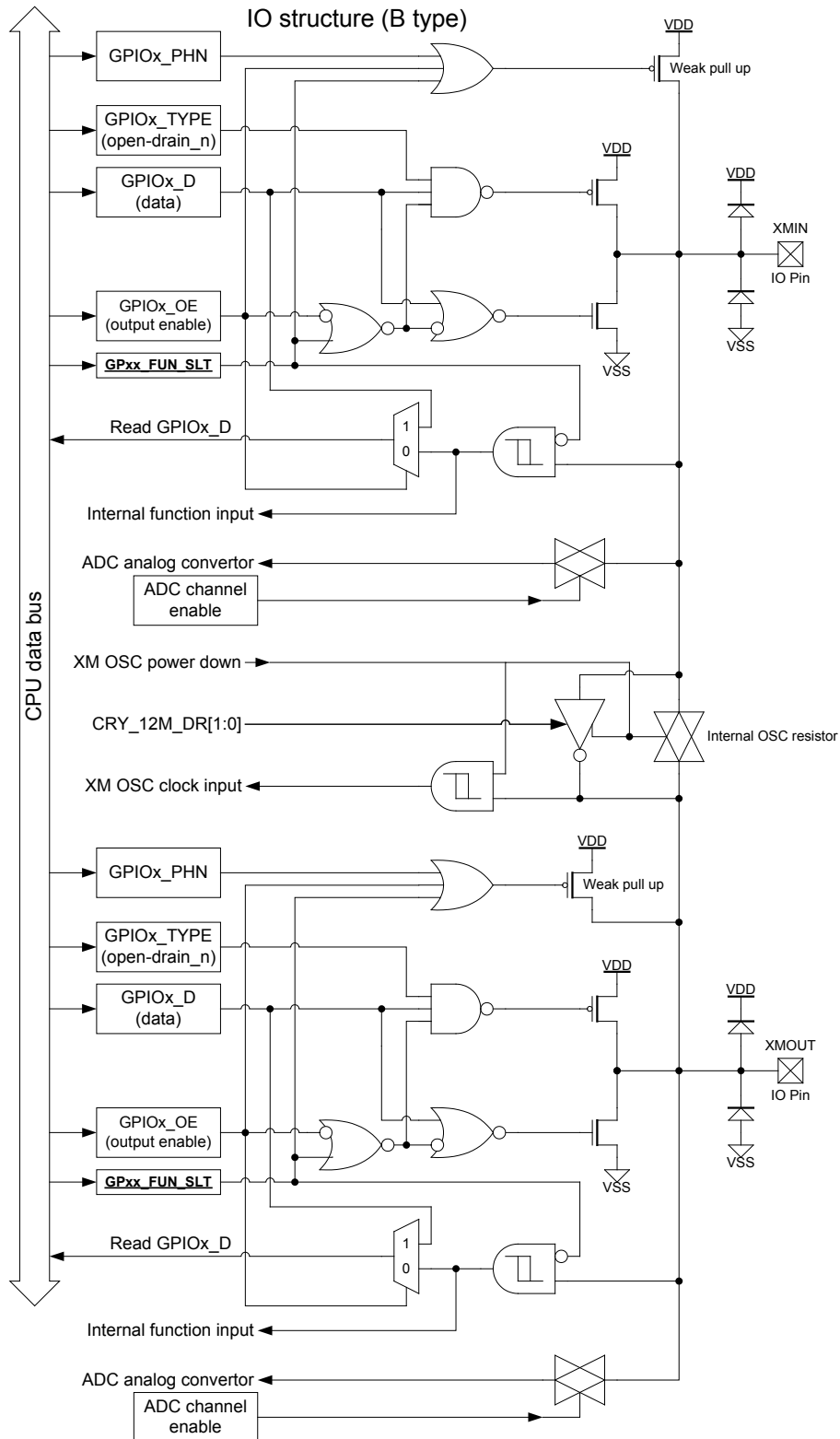

**I/O Structure (Type C1)**

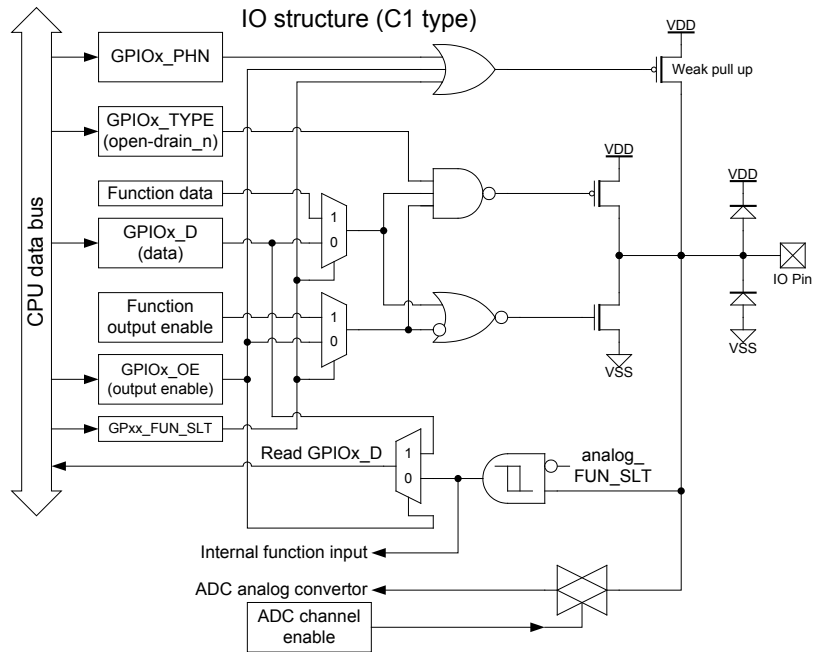

**I/O Structure (Type C2)**

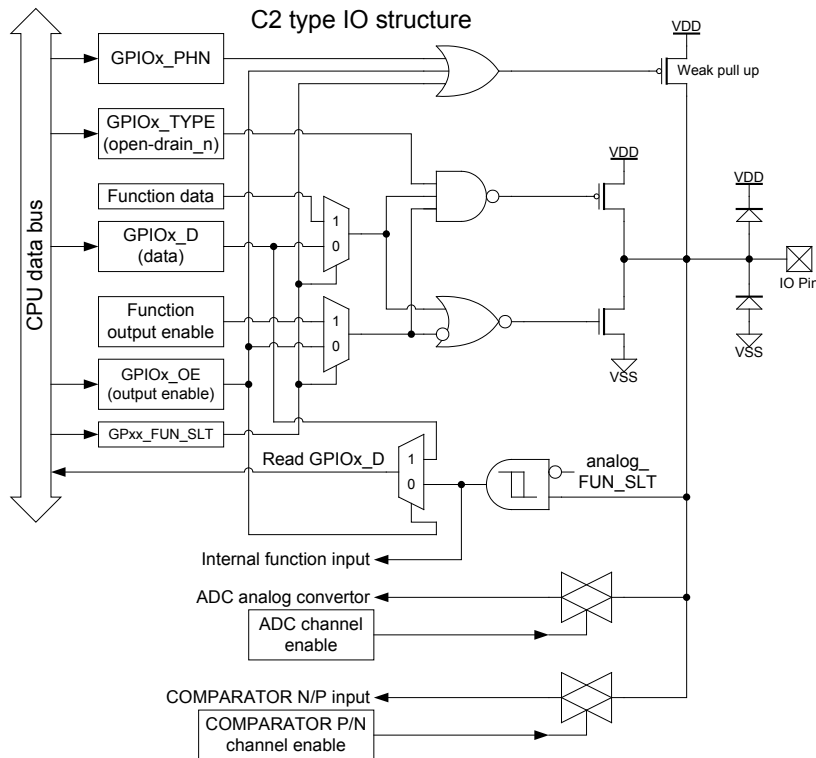



## 5. Normal Function

### 5.1 CPU

The WT51F104 has an embedded 8-bit 1T 8052 compatible CPU with 16-bit space addressable and 8-bit data access functions. The instruction execution time of 1T 8052 is three times faster than that of the conventional 3T 8052, and 12 times faster than that of 12T 8052. All of the functions and Special Function Register (SFR) definitions will be described in below sections.

### 5.2 RAM

The WT51F104 consists of 256 Bytes of SRAM. The 256 Bytes of RAM is the internal RAM of the general 8052. Below figure shows a map of the RAM. For Peripheral Control Registers, see section 6.1.

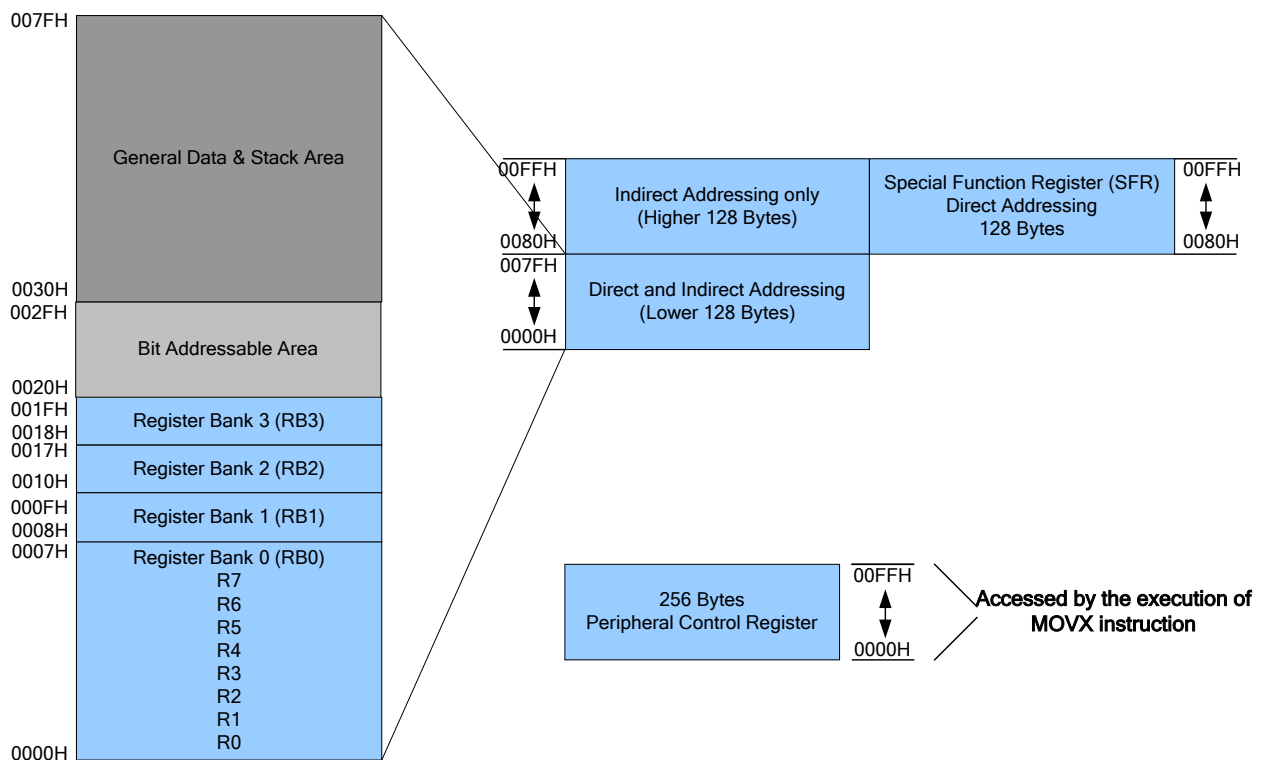

The internal SRAM contains:

128 Bytes of internal SRAM, locates from 0x0000H to 0x007FH (direct and indirect addressing is allowed)

128 Bytes of internal SRAM, locates from 0x0080H to 0x00FFH (indirect addressing)

Its main purpose is for storing data in the program, and therefore it is also called Data Memory. The Data memory of WT51F104 includes the following sections:

- (1) The lower 128 bytes of internal SRAM (0000H ~ 007FH) which can be accessed by direct or indirect addressing is divided into 3 segments:

**General Purpose Register:** Locates from 0000H to 001FH, 32 Bytes in total, can be divided into 4 register banks. Each register bank contains 8 general purpose registers (R0~R7). 4 register banks can be selected by the select bit RS1 and RS0 in the Program Status Word Register.

**Bit Addressable Area:** Locates from 20H to 2FH, 16 Bytes in total. Each one of the 128 bits of this segment can be directly addressed by Bit Addressing.

**General Data Area:** Locates from 0030H to 007FH, 80 Bytes are available to the user as data RAM (including the Stack area).

(2) The higher 128 bytes of internal SRAM (0080H ~ 00FFH) can be accessed by indirect addressing through R0 or R1 (\*).

(3) Special Function Registers (SFR), locates from 0080H to 00FFH, can be accessed by direct addressing (\*).

(\*) Although the SFR and the higher 128 Bytes of internal RAM occupy the same addresses (0080H ~ 00FFH), they are two separate areas. MCU will automatically determine which area is in use by two different accessing ways.

### 5.3 Flash Memory

The WT51F104 consists of 4K built-in flash, which can be served as general Program memory or simulated E<sup>2</sup>PROM (0x0C00H ~ 0x0EFFH) with features as below:

- ◆ FLASH memory: 4K Bytes
- ◆ Operating voltage: 1.8V ~ 5.5V
- ◆ In-System Programming (ISP)
- ◆ Over 10 years Data Retention
- ◆ Read Out Protection and Code Encryption
- ◆ Emulated E<sup>2</sup>PROM function

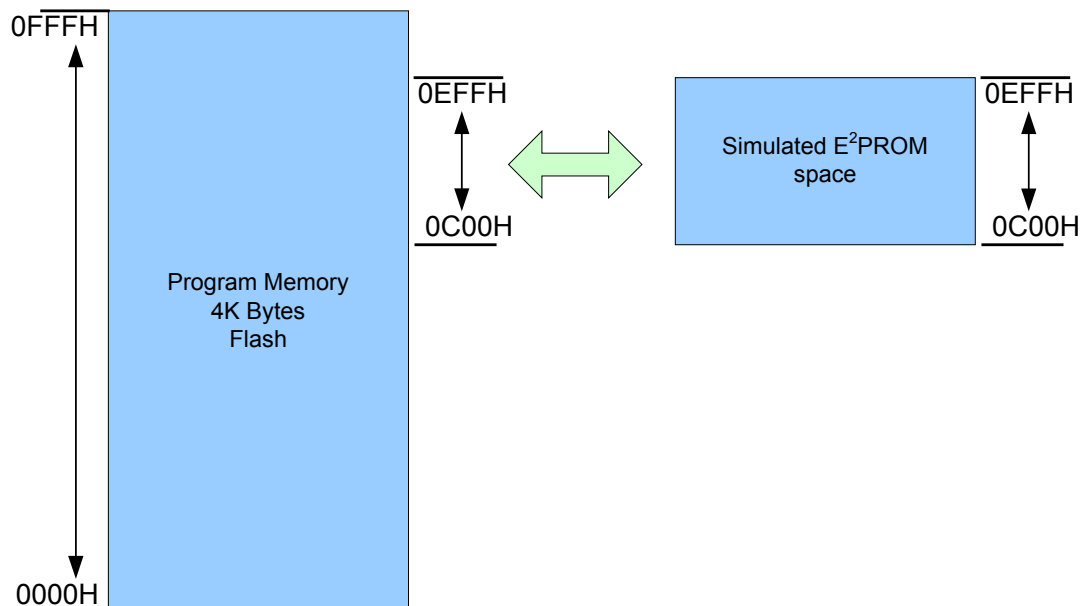

**Note:** The last 8 bytes of FLASH is Code Option, and the available flash ranges from 0x000H to 0xFF7H.

## 5.4 Memory Mapping

WT51F104 built-in 128 Bytes of direct addressing 8052 standard Special Function Register (SFR), as described below.

- CPU Core Register: ACC, B, PSW, SP, DPL0, DPH0, DPL1, DPH1, DPS
- Interrupt Register: IP, IE, XICON
- I/O Port Register: P0
- Timer Register: TCON, TMOD, TL0, TH0, TL1, TH1
- UART0 Register: SCON0, SBUF0, SBRG0H, SBRG0L, PCON

### Special Function Register (SFR) MAP:

Bit Addressable		No Bit Addressable						
F8H								FFH
F0H	B							F7H
E8H								EFH
E0H	ACC							E7H
D8H								DFH
D0H	PSW							D7H
C8H								CFH
C0H	XICON							C7H
B8H	IP							BFH
B0H								B7H
A8H	IE							AFH
A0H								A7H
98H	SCON0	SBUF0	SBRG0H	SBRG0L				9FH
90H								97H
88H	TCON	TMOD	TL0	TL1	TH0	TH1		8FH
80H	P0	SP	DPL0	DPH0	DPL1	DPH1	DPS PCON	87H

### Special Function Register (SFR) Table:

Register Name	Address	Reset Value	Description
SP	81H	07H	Stack Pointer
DPL0	82H	00H	Data Pointer 0, low byte
DPH0	83H	00H	Data Pointer 0, high byte
DPL1	84H	00H	Data Pointer 1, low byte
DPH1	85H	00H	Data Pointer 1, high byte
DPS	86H	00H	Data Pointer select
PCON	87H	00H	Power Control Register

Register Name	Address	Reset Value	Description
TCON	88H	00H	Timer 0/1 Counter Control
TMOD	89H	00H	Timer 0/1 Mode Control
TL0	8AH	00H	Timer 0, low byte
TL1	8BH	00H	Timer 1, low byte
TH0	8CH	00H	Timer 0, high byte
TH1	8DH	00H	Timer 1, high byte
SCON0	98H	00H	Serial Port 0, Control Register
SBUF0	99H	00H	Serial Port 0, Data Buffer
SBRG0H	9AH	00H	Serial Baud rate Generator, high byte
SBRG0L	9BH	00H	Serial Baud rate Generator, low byte
IE	A8H	00H	Interrupt Enable Register
IP	B8H	00H	Interrupt Priority Register 1
XICON	C0H	00H	Interrupt Enable Register (INT2/INT3)
PSW	D0H	00H	Program Status Word
ACC	E0H	00H	Accumulator
B	F0H	00H	B Register

**Note: Refer to 5.7 “Reset” section for the initial value of SFR.**

**Introduction of WT51F104 CPU SFR is as below:**

**B: Address: F0H**

**Reset Value: 00h**

7	6	5	4	3	2	1	0
B.7	B.6	B.5	B.4	B.3	B.2	B.1	B.0

The B register is used during multiply and divide operations. It can store the multiplier and the high bytes of operation result in multiply operation, and also the divisor and the remainder of operation result in divide operation. The B register can be used as a general register.

**ACC: Address: E0H**

**Reset Value: 00h**

7	6	5	4	3	2	1	0
ACC.7	ACC.6	ACC.5	ACC.4	ACC.3	ACC.2	ACC.1	ACC.0

ACC is the Accumulator register, used for data operations.

**PSW (Program Status Word): Address: D0H**

**Reset Value: 00h**

7	6	5	4	3	2	1	0
CY	AC	F0	RS1	RS0	OV	F1	PARITY

The Program Status Word contains program status information.

Bit Number	Bit Mnemonic	Description
7	CY	Carry Flag, used to indicate the result of arithmetic operation whether a carry or borrow occurred in the 7 <sup>th</sup> bit. Operation result of Addition: CY = 1: a carry occurred; CY = 0: no carry occurred. Operation result of Subtraction: CY = 1: a borrow occurred; CY = 0: no borrow occurred.
6	AC	Auxiliary-Carry Flag, used to indicate the result of arithmetic operation whether the 3 <sup>rd</sup> bit borrow (or carry) from the 4 <sup>th</sup> bit occurred. Operation result of Addition: AC = 1: a carry occurred; AC = 0: no carry occurred. Operation result of Subtraction: AC = 1: a carry occurred; AC = 0: no carry occurred.
5	F0	General purpose flag, can be served as general purpose read/write bit.
4	RS1	Register Bank Select bits 1 and 0 (refer to Register Bank Selection Table).
3	RS0	
2	OV	Overflow Flag, used to indicate the result of arithmetic operation whether an overflow occurred. If OV = 1, an overflow occurred. Otherwise, it is cleared.
1	F1	General-purpose flag, can be used as normal read/write bit.
0	P	Parity Flag. It is set to indicate an odd number of "1" bits in the accumulator. Otherwise, it is cleared.

**Register Bank Selection Table:**

Register Bank	Address	RS1	RS0
0	00H ~ 07H	0	0
1	08H ~ 0FH	0	1
2	10H ~ 17H	1	0
3	18H ~ 1FH	1	1

**SP (Stack Point) Address: 81H**
**Reset Value: 07h**

7	6	5	4	3	2	1	0
SP.7	SP.6	SP.5	SP.4	SP.3	SP.2	SP.1	SP.0

Stack Pointer, indicated the location at which the last byte was pushed onto the stack. It is incremented before data is stored during PUSH.

**DPL0 (DPTR0, low byte of the 16-bit data pointer 0) Address: 82H**
**Reset Value: 00h**

7	6	5	4	3	2	1	0
DPL0.7	DPL0.6	DPL0.5	DPL0.4	DPL0.3	DPL0.2	DPL0.1	DPL0.0

DPL0 is a low byte of DPTR0, using together with the data pointer of DPH0.

**DPH0 (DPTR0, high byte of the 16-bit data pointer 0) Address: 83H Reset Value: 00h**

7	6	5	4	3	2	1	0
DPH0.7	DPH0.6	DPH0.5	DPH0.4	DPH0.3	DPH0.2	DPH0.1	DPH0.0

DPH0 is a high byte of DPTR0, using together with the data pointer of DPL0.

**DPL1 (DPTR1, low byte of the 16-bit data pointer 1) Address: 84H Reset Value: 00h**

7	6	5	4	3	2	1	0
DPL1.7	DPL1.6	DPL1.5	DPL1.4	DPL1.3	DPL1.2	DPL1.1	DPL1.0

DPL1 is a low byte of DPTR1, using together with the data pointer of DPH1.

**DPH1 (DPTR1, high byte of the 16-bit data pointer 1) Address: 85H Reset Value: 00h**

7	6	5	4	3	2	1	0
DPH1.7	DPH1.6	DPH1.5	DPH1.4	DPH1.3	DPH1.2	DPH1.1	DPH1.0

DPH1 is a high byte of DPTR1, using together with the data pointer of DPL1.

**DPS (Data point select) Address: 86H Reset Value: 00h**

7	6	5	4	3	2	1	0
							DPS

Data Point selection: If DPS = 0, selects DPTR0 (DPH0, DPL0)  
 If DPS = 1, selects DPTR1 (DPH1, DPL1)

**Note: Other special function registers will be discussed in later sections.**

## 5.5 In-System Programming (ISP) (Important!!! Must Read!!!)

In-System Programming function allows users to perform programming on the target board directly without removing any components.

**ISP interface adopts:**

3-wire: VDD, GND (VSS), SWUT

2-wire: SWUT, GND (VSS), if the target board already has VDD power.

The figure below illustrates pins of ISP interface:

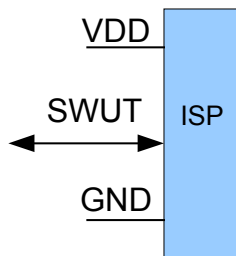

**Note:** See WT51F104 WLINK-SWUT ISP User's Manual for more details.

### 5.5.1 In-System Programming Notice

Condition: MCU SOURCE clock 12 MHz (Internal/External Oscillator). For more details, please refer to Chapter 8 Application Circuits.

Description: Since this series of MCU adopts single-wire UART (SWUT) for sytem programming and the baud rate is 115200 bps, SOURCE clock of MCU must work at 12 MHz. In addition, the default setting of MCU is IRC 12 MHz, and thus direct In-System Programming is supported. It requires adding trigger or wakeup conditions if MCU works at external 24 MHz, Green Mode, Idle Mode or Sleep Mode, otherwise programming procedures will fail. The following section will explain how to operate in those modes. (For more details on reference clock source, please refer to section 3.1)

GPIOxx/RESET/SWUT pin supports Reset function/Input/Programming function at the same time, but each level is different, please refer to the table below:

Function (VDD = 5.0V)	VIH	VIL	Function (VDD = 3.5V)	VIH	VIL
SWUT	0.83 VDD	0.57 VDD	SWUT	0.81 VDD	0.52 VDD
NRST	0.45 VDD	0.24 VDD	NRST	0.49 VDD	0.27 VDD

**The programming voltage of SWUT ranging between 2.2V and 5.5V. If the programming voltage is below 2.7V, the internal pull high of GPIOA3 pin must be disabled. (XFR 0x1C GPIOA\_PHN[3])**

### **Normal Mode:**

If MCU works at 12 MHz (Internal/External Oscillator), and MCU performs Power On Reset normally, the programming process can go smoothly.

MCU works together with special frequency External Oscillator, such as 1 MHz, 4 MHz, 8 MHz, and 24 MHz crystal oscillator. Since the SWUT baud rate is not 115200 bps, MCU cannot perform programming directly. It requires setting ISP Clock Source Control Register (ISP\_CHG\_CTL) to enable two control bits (Bit7 ISP\_CHG\_12M & Bit5 UART\_ISP\_CHG), which allows SWUT pin to receive trigger signal. After the MCU being switched to Internal Oscillator 12 MHz automatically, the programming process will succeed. For more details, please refer to section 6.7.

### **Green Mode**

It is so-called Green Mode when MCU works at 32 kHz (Internal/External Oscillator). MCU cannot perform programming directly when works at this mode. It requires setting ISP Clock Source Control Register (ISP\_CHG\_CTL) to enable two control bits (Bit7 ISP\_CHG\_12M & Bit5 UART\_ISP\_CHG), which allows SWUT pin to receive trigger signal. After the MCU being switched to Internal Oscillator 12 MHz automatically, the programming process will succeed. For more details, please refer to section 6.7.

### **Idle Mode:**

Before entering this mode, in addition to setting ISP Clock Source Control Register (ISP\_CHG\_CTL) to enable two control bits (Bit7 ISP\_CHG\_12M & Bit5 UART\_ISP\_CHG), be sure to set up wakeup conditions. Then MCU can switch back to work at 12 MHz, and maintain 2 ~ 3 seconds to receive the programming command from SWUT. For more details, please refer to section 6.7.

### **Sleep Mode:**

Before entering this mode, in addition to setting ISP Clock Source Control Register (ISP\_CHG\_CTL) to enable two control bits (Bit7 ISP\_CHG\_12M & Bit5 UART\_ISP\_CHG), be sure to set up wakeup conditions. Then MCU can switch back to work at 12 MHz, and maintain 2 ~ 3 seconds to receive the programming command from SWUT. For more details, please refer to section 6.7.



**Recommended Circuit:**

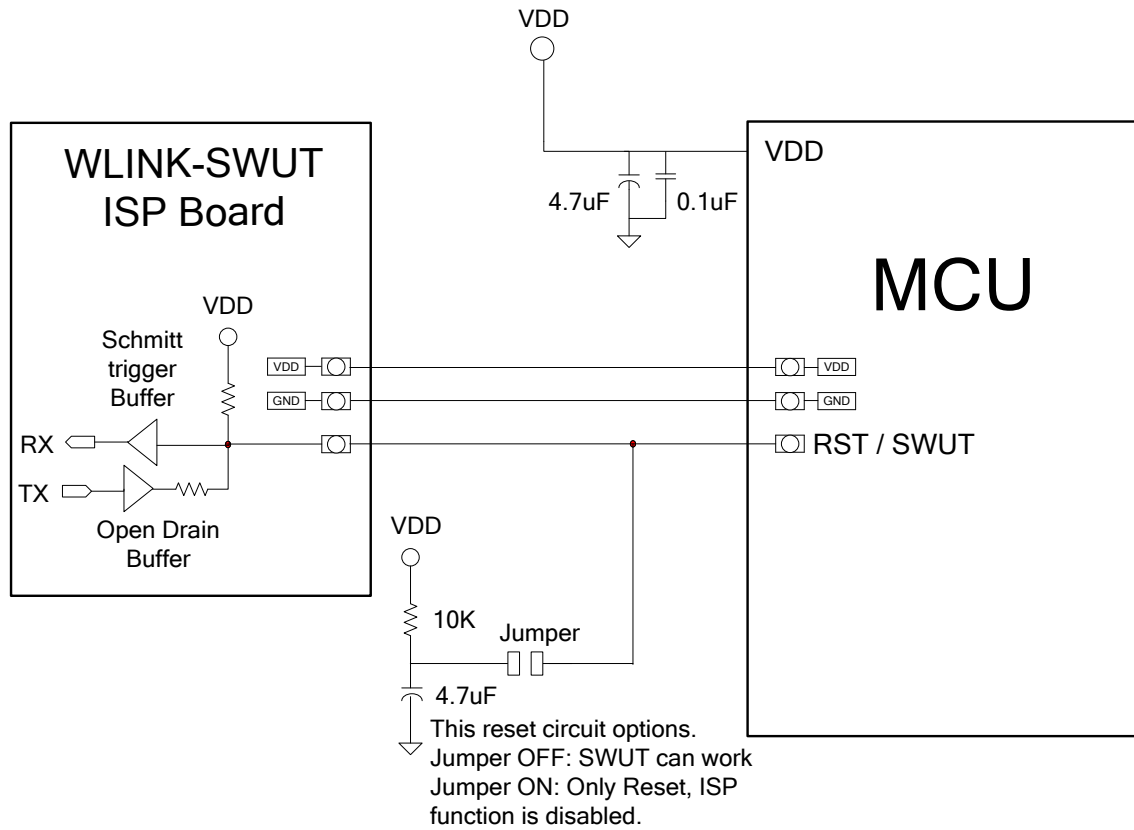

## 5.6 Timer/Counter

The WT51F104 contains two 16-bit Timer/Counters (Timer0 ~ 1). Both Timer/Counters can be configured as Timer or Counter.

### 5.6.1 Timer/Counter0 & Timer/Counter1 (Timer 0/1)

The internal Timer/Counter 0 and Timer/Counter 1 of WT51F104 have four operation modes to be selected by bits M11, M10, or M01, M00 respectively in the Special Function Register TMOD, as described below.

**TMOD (8052 Timer0/1 mode control register) Address: 89H**

7	6	5	4	3	2	1	0
GATE1	C1/T1	M11	M10	GATE0	C0/T0	M01	M00

Bit Number	Bit Mnemonic	Description
7	GATE1	GATE1 = 1, invalid GATE1 = 0, configured as internal Timer. If TR1 = 1, Timer1 starts.
6	C1/T1	Timer/Counter 1 selector C1/T1 = 1, configured as an external Timer, and the counter signal is from external pin (GPIOA5/T1) C1/T1 = 0, configured as an internal Timer, and the counter signal is from MCU Clock 12 MHz IRC ÷ 12
5-4	M11-M10	Timer/Counter 1 mode selection bits 00: Mode 0, 13-bit Timer/Counter 01: Mode 1, 16-bit Timer/Counter 10: Mode 2, 8-bit auto-reload Timer/Counter 11: Mode 3, Timer/Counter 1 stopped and retained count
3	GATE0	GATE0 = 1, invalid GATE0 = 0, configured as internal Timer. If TR0 = 1, Timer0 starts.
2	C0/T0	Timer/Counter 0 selector C0/T0 = 1, configured as an external Timer, and the counter signal is from external pin (GPIOA2/T0) input C0/T0 = 0, configured as an internal Timer, and the counter signal is from MCU Clock 12 MHz IRC ÷ 12
1-0	M01-M00	Timer/Counter 0 mode selection bits 00: Mode 0, 13-bit Timer/Counter 01: Mode 1, 16-bit Timer/Counter 10: Mode 2, 8-bit auto-reload Timer/Counter 11: Mode 3, 8-bit Timer/Counter (TL0 uses TR0 bit and TH0 uses TR1 bit)

**TCON (8052 Timer 0/1 control register) Address: 88H**

7	6	5	4	3	2	1	0
TF1	TR1	TF0	TR0	-	-	-	-

Bit Number	Bit Mnemonic	Description
7	TF1	Timer/Counter 1 Overflow Flag. When the Timer/Counter overflows, TF1 is set (TF1 = 1). When CPU is jumped to the Interrupt Service Routine of Timer/Counter 1, TF1 is auto-cleared (TF1 = 0).
6	TR1	Timer/Counter 1 Enable bit. If TR1 is set (TR1 = 1), Timer/Counter 1 is in use; If TR1 is disabled (TR1 = 0), Timer/Counter 1 stopped.
5	TF0	Timer/Counter 0 Overflow Flag. When the Timer/Counter overflows, TF0 is set (TF0 = 1). When the CPU is jumped to the Interrupt Service Routine of Timer/Counter 0, TF0 is auto-cleared (TF0 = 0).
4	TR0	Timer/Counter 0 Enable bit. If TR0 is set (TR0=1), Timer/Counter 0 is in use; If TR0 is disabled (TR0=0), Timer/Counter 0 stopped.
3-0	-	Invalid

**Note:** See section 6.4 for more information on Baud rate generator of Timer/Counter 1.

**Mode 0:**

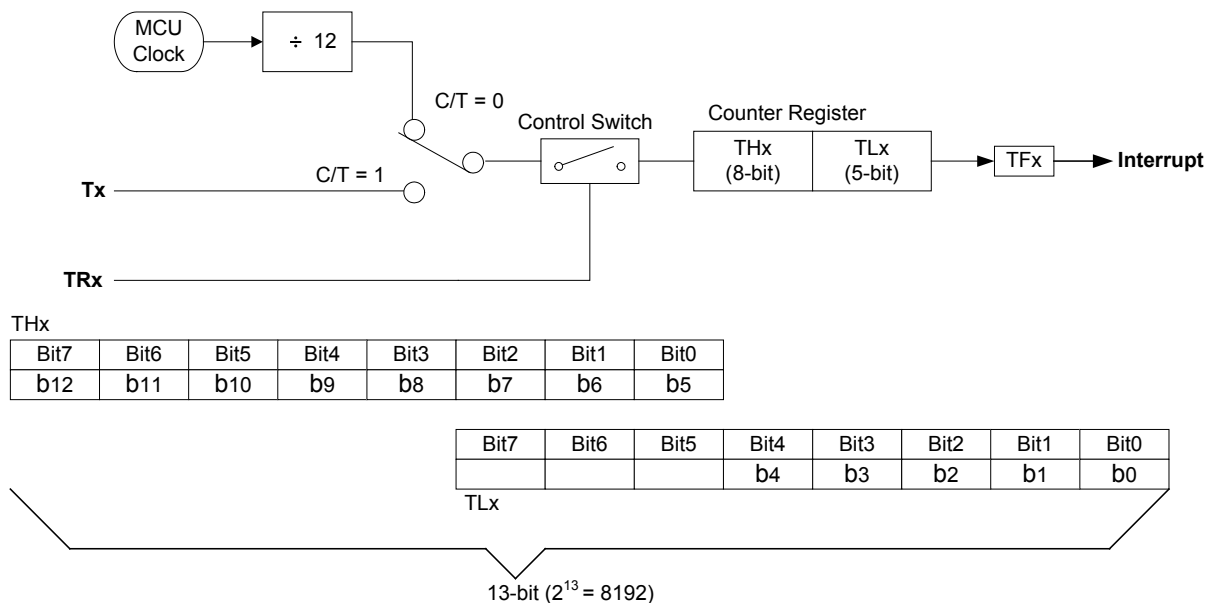

Mode 0 operation is the same for Timer/Counter 0 and Timer/Counter 1. In this mode, the timer register is configured as a 13-bit Up Timer/Counter, which consists of the Special Function Register THx and TLx. As the count of the 13 bits is all 1s, if the register incremented 1 then count of the B bit is all 0s and meantime if the Timer/Counter Interrupt is enabled, an Timer overflow interrupt will occur and Overflow Flag is set (TFx = 1).

**Mode 1:**

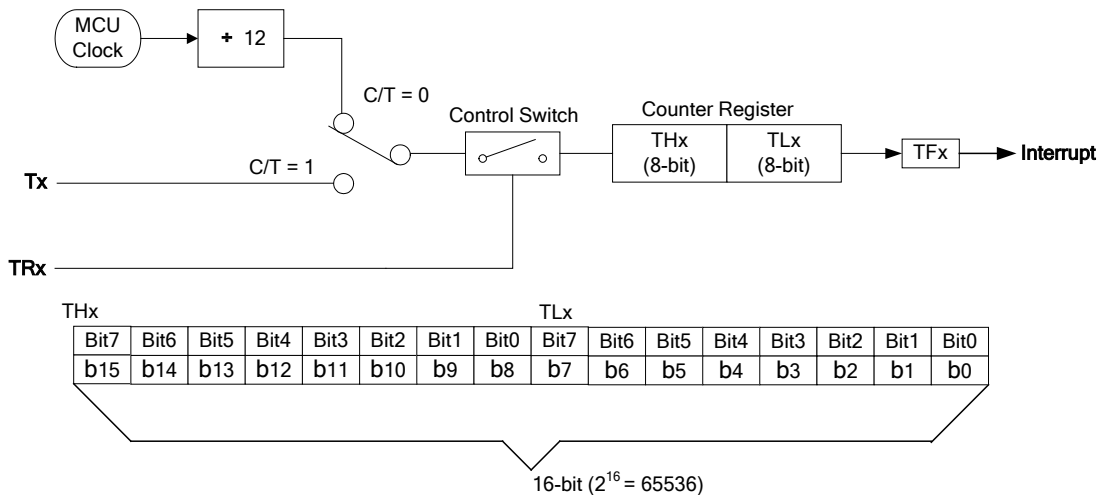

Mode 1 operation is the same as Mode 0 for Timer/Counter 0 and Timer/Counter 1, except that the Timer Register which consists of THx and TLx is configured as a 16-bit Up Timer/Counter.

**Mode 2:**

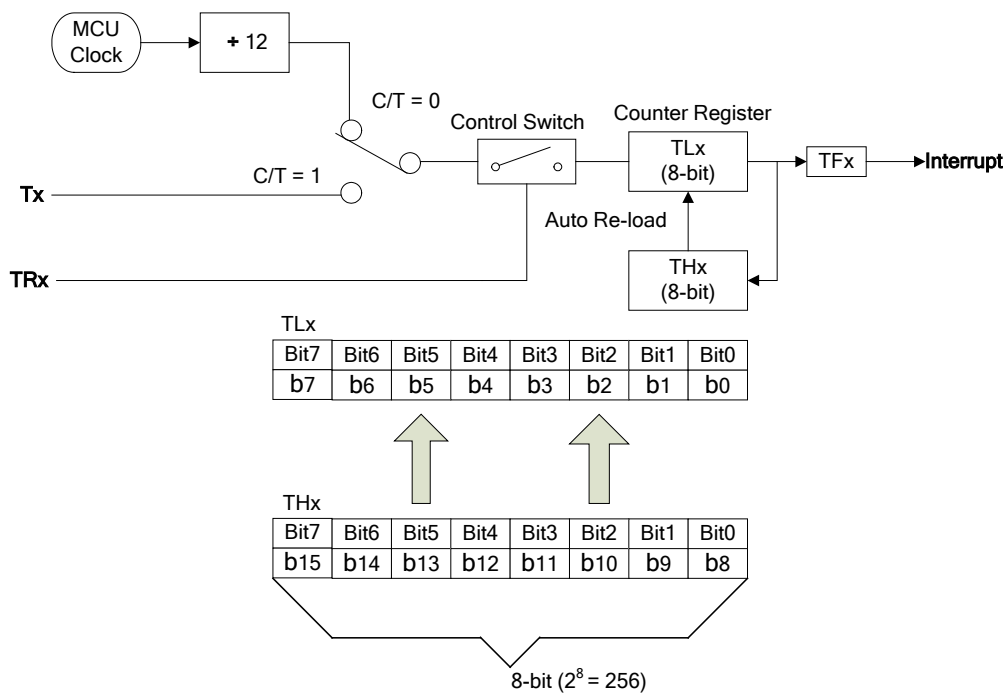

Mode 2 operation is the same for Timer/Counter 0 and Timer/Counter 1 to configure two 8-bit auto-reload Timer/Counters. The counter value is stored in TLx Register. Overflow from TLx not only sets TFX = 1, but also auto-reloads contents of THx to TLx.

**Mode 3:**

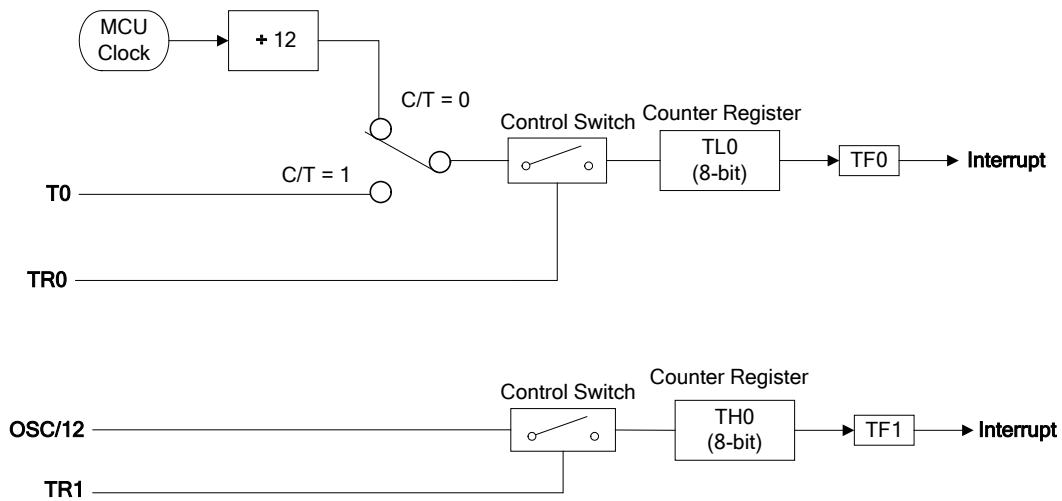

Mode 3 operation is rarely different for Timer/Counter 0 and Timer/Counter 1, as described below.

In Mode 3, TL0 is an 8-bit Timer/Counter, while TH0 is an 8-bit Counter controlled by TR1. In the meantime, be aware of the Overflow Flag of Timer/Counter 1 borrowed by TH0, and the corresponding Interrupt Service Routine address is 001BH. In Mode 3, Timer/Counter 1 stopped and retained count.

## 5.7 Reset

The WT51F104 has seven reset generation sources: Power On Reset (POR), Low Voltage Reset (LVR), Low Voltage Detection Reset (LVDR), External NRST pin Reset, Watchdog Reset, ISP/ICE Command Reset, and PC Counter Overflow Reset (PC\_OVR). During Reset, all registers are reset to their initial values. You may judge what kind of reset is generated by Reset Flag Register (XFR 0x03).

### Power-on Reset (POR)

The Power-on Reset occurs when the VDD supply voltage is below the Power-on Reset voltage threshold (refer to DC Characteristics sections for more details), then XFR: 0x03 POR\_RST\_FLG = 1.

### Low Voltage Reset (LVR)

A reset occurs when the VDD voltage is below the operating voltage threshold, then XFR: 0x03 LVR\_RST\_FLG = 1.

### Low Voltage Detection Reset (LVDR)

A reset occurs when the VDD voltage is below the Low Voltage Detection setting level, then XFR: 0x03 LVD\_RST\_FLG = 1.

### External NRST pin Reset

A reset occurs when the voltage of the external reset pin (NRST) is below its VIL (refer to DC characteristics sections for more details), then XFR: 0x03 NRST\_FLG = 1.

### Watchdog Timer Reset

A reset occurs when the Watchdog Timer times out, then XFR: 0x03 WDT\_RST\_FLG = 1.

### ISP/ICE Command Reset

An ISP/ICE reset occurs when SWUT pin transmitted the reset command, then XFR: 0x03 ISP\_RST\_FLG = 1.

### PC Counter Overflow Reset (PC\_OVR)

The PC counter stores the address where the current instruction locates. A reset occurs when the address exceeds the range of the Flash memory (Flash Address 0x0000 ~ 0x3FFF), then XFR: 0x03 PC\_OVL\_RST\_FLG = 1.

### Reset status

When above condition occurred, all Special Function Registers are set to their initial values. SFR contents are described in the following text. XFR contents will be discussed in next section.

The initial value of Special Function Register after Reset (as shown below):

SFR	Initial Value	SFR	Initial Value
P0	11111111b	P2	11111111b
SP	0000111b	IE	0000000b
DPL0	0000000b	P3	11111111b
DPH0	0000000b	IP	xx00000b
DPL1	0000000b	T2CON	0000000b
DPH1	0000000b	T2MOD	xxxxxx00b
DPS	0000000b	RCAP2L	0000000b
PCON	0000000b	RCAP2H	0000000b
TCON	0000000b	TL2	0000000b
TMOD	0000000b	TH2	0000000b
TL0	0000000b	PSW	0000000b
TL1	0000000b	SCON1	0000000b
TH0	0000000b	SBUF1	0000000b
TH1	0000000b	ACC	0000000b
P1	11111111b	B	0000000b
SCON0	0000000b	XICON	0000000b
SBUF0	0000000b		
SBRG0H	0000000b		
SBRG0L	0000000b		

## 5.8 System Clock and Clock sources

The WT51F104 contains three clock sources: 32.768 kHz ~ 24 MHz external crystal oscillator, internal 12 MHz RC oscillator, and internal 32 kHz RC oscillator. The MCU clock sources are selected by External Special Function Register (XFR) SOURCE\_CLK\_SLT [1:0] and MCU\_CLK\_SLT [1:0]. The initial value is internal 12 MHz RC oscillator and without using a prescaler, at the same time MCU works at 12 MHz operating frequency. For more details, refer to section 6.7 Power Management.

Clock Sources are listed below.

Main Clock Sources	Sub Clock Sources
DC ~ 24 MHz Crystal Oscillator	32K Internal RC Oscillator
12 MHz Internal RC Oscillator	32K Internal RC Oscillator
12 MHz Internal RC Oscillator	32.768 kHz Crystal Oscillator

## 6. Enhanced Function

### 6.1 External Special Function Register (XFR)

External Special Function Register (XFR) locates from 0x00 ~ 0xFF, must be accessed by the execution of MOVX instruction.

External Special Function Register Table:

External memory address	Description
0000H ~ 000FH	System Register, Low Voltage Detection and Reset Register
0010H ~ 001FH	General-purpose I/O port Register
0020H ~ 002FH	General-purpose I/O port Register and Multi-function Register
0030H ~ 003FH	Interrupt Enable Register
0040H ~ 004FH	External Interrupt Request Register (IRQ)
0050H ~ 005FH	Pulse Width Modulation Register (PWM)
0060H ~ 006FH	Wakeup Register
0070H ~ 007FH	Internal Oscillator Calibration Register, Watchdog Register, Watch Timer Register
00A0H ~ 00AFH	I <sup>2</sup> C Serial Port Interface Register
00B0H ~ 00BFH	Enhanced Timer/Counter Register
00C0H ~ 00CFH	SPI Serial Port Interface Register
00D0H ~ 00D7H	10-bit Analog/Digital Register
00DAH ~ 00DFH	Comparator Register
00E0H ~ 00EFH	Simulated E <sup>2</sup> PROM Register

When the Reset status which is mentioned in section 5.7 occurred, the default value of external function register after reset is listed below:

Register Name	Address	Reset Default (Hex)	Index Section
Reserved	-	-	
System Control Register	0x01	80	6.9
Low Voltage Detection Control Register	0x02	A6	6.15; 6.16
Reset Flag Register	0x03	01	6.16
ISP Clock Source Control Register	0x04	00	6.7
System Clock Source Control Register	0x05	A0	6.7
Power Saving Control Register	0x06	50	6.7
Clock Source Control Register	0x07	A2	6.7
Oscillator Driver Control Register	0x08	54	6.7
External Clock Source Prescaler Control Register 1	0x09	01	6.9



Register Name	Address	Reset Default (Hex)	Index Section
External Clock Source Prescaler Control Register 2	0x0A	76	6.9
Customer Code Register 1	0x0D	FF	6.18
Customer Code Register 2	0x0E	FF	6.18
Customer Code Register 3	0x0F	FF	6.18
General-purpose I/O Port A Output Enable Control Register	0x10	00	6.2
General-purpose I/O Port B Output Enable Control Register	0x11	00	6.2
General-purpose I/O Port C Output Enable Control Register	0x12	00	6.2
General-purpose I/O Port A Data Register	0x16	00	6.2
General-purpose I/O Port B Data Register	0x17	00	6.2
General-purpose I/O Port C Data Register	0x18	00	6.2
General-purpose I/O Port A Enable Internal Pull-up Resistor Register	0x1C	3F	6.2
General-purpose I/O Port B Enable Internal Pull-up Resistor Register	0x1D	3F	6.2
General-purpose I/O Port C Enable Internal Pull-up Resistor Register	0x1E	3F	6.2
General-purpose I/O Port A Output Type Control Register	0x22	3F	6.2
General-purpose I/O Port B Output Type Control Register	0x23	3F	6.2
General-purpose I/O Port C Output Type Control Register	0x24	3F	6.2
General-purpose I/O Port A Complex Function Setting Register 1	0x25	00	6.2
General-purpose I/O Port A Complex Function Setting Register 2	0x26	00	6.2
General-purpose I/O Port A Complex Function Setting Register 3	0x27	00	6.2
General-purpose I/O Port B Complex Function Setting Register 1	0x28	00	6.2
General-purpose I/O Port B Complex Function Setting Register 2	0x29	00	6.2
General-purpose I/O Port B Complex Function Setting Register 3	0x2A	00	6.2
General-purpose I/O Port C Complex Function Setting Register 1	0x2B	00	6.2
General-purpose I/O Port C Complex Function Setting Register 2	0x2C	00	6.2
General-purpose I/O Port C Complex Function Setting Register 3	0x2D	00	6.2
8052 External Interrupt 0 Control Register	0x30	00	6.3
8052 External Interrupt 1 Control Register	0x31	00	6.3
8052 External Interrupt 2 Control Register	0x32	00	6.3
8052 External Interrupt 3 Control High Bytes Register	0x33	00	6.3
8052 External Interrupt 3 Control Low Bytes Register	0x34	00	6.3
8052 External Interrupt 0 (INT0) Flag Register	0x35	00	6.3
8052 External Interrupt 1 (INT1) Flag Register	0x36	00	6.3
8052 External Interrupt 2 (INT2) Flag Register	0x37	00	6.3

Register Name	Address	Reset Default (Hex)	Index Section
8052 External Interrupt 3 (INT3) Flag High Bytes Register	0x38	00	6.3
8052 External Interrupt 3 (INT3) Flag Low Bytes Register	0x39	00	6.3
External Interrupt Request (IRQ) Control High Bytes Register	0x40	00	6.5
External Interrupt Request (IRQ) Control Low Bytes Register	0x41	00	6.5
External Interrupt Request (IRQ) Status High Bytes Register	0x42	00	6.5
External Interrupt Request (IRQ) Status Low Bytes Register	0x43	00	6.5
External Interrupt Request (IRQ) Clear High Bytes Register	0x44	00	6.5
External Interrupt Request (IRQ) Clear Low Bytes Register	0x45	00	6.5
External Interrupt Request (IRQ) Bi-directional Trigger High Bytes Register	0x46	00	6.5
External Interrupt Request (IRQ) Bi-directional Trigger Low Bytes Register	0x47	00	6.5
External Interrupt Request (IRQ) Trigger Edge High Bytes Register	0x48	00	6.5
External Interrupt Request (IRQ) Trigger Edge Low Bytes Register	0x49	00	6.5
PWM Control Register	0x50	00	6.6
PWM0 Period Control High Bytes Register	0x51	00	6.6
PWM0 Period Control Low Bytes Register	0x52	01	6.6
PWM0 Duty Cycle Control High Bytes Register	0x53	00	6.6
PWM0 Duty Cycle Control Low Bytes Register	0x54	00	6.6
PWM1 Period Control High Bytes Register	0x55	00	6.6
PWM1 Period Control Low Bytes Register	0x56	01	6.6
PWM1 Duty Cycle Control High Bytes Register	0x57	00	6.6
PWM1 Duty Cycle Control Low Bytes Register	0x58	00	6.6
General-purpose I/O Port A Wakeup Control Register	0x60	00	6.7
General-purpose I/O Port B Wakeup Control Register	0x61	00	6.7
General-purpose I/O Port C Wakeup Control Register	0x62	00	6.7
Peripheral Interrupt Wakeup Control Register	0x64	00	6.7
General-purpose I/O Port A Wakeup Flag Register	0x65	00	6.7
General-purpose I/O Port B Wakeup Flag Register	0x66	00	6.7
General-purpose I/O Port C Wakeup Flag Register	0x67	00	6.7
Peripheral Interrupt Wakeup Flag Register	0x69	00	6.7
Wakeup Clear Register	0x6A	00	6.7
Internal Oscillator Adjust Register	0x70	40	6.8
Internal Oscillator Counter Data High Bytes Register	0x71	00	6.8
Internal Oscillator Counter Data Low Bytes Register	0x72	00	6.8
Internal Oscillator Calibration Control Register	0x73	00	6.8

Register Name	Address	Reset Default (Hex)	Index Section
Watchdog Timer Control Register	0x78	02	6.9
Watch Timer Control Register	0x7C	80	6.9
Watch Timer Output Selection Register	0x7D	00	6.9
Master/Slave I <sup>2</sup> C Control Register	0xA0	40	6.10
Master/Slave I <sup>2</sup> C Status Register	0xA1	00	6.10
Master/Slave I <sup>2</sup> C Transmit Buffer Register	0xA2	00	6.10
Master/Slave I <sup>2</sup> C Transmit and Receive Buffer Register	0xA3	FF	6.10
Slave I <sup>2</sup> C Address Register	0xA4	00	6.10
Master/Slave I <sup>2</sup> C Extended Control Register	0xA5	00	6.10
Enhanced Timer/Counter Control Register 1	0xB0	00	6.11
Enhanced Timer/Counter Control Register 2	0xB1	00	6.11
Enhanced Timer/Counter Interrupt Register	0xB2	00	6.11
Enhanced Timer/Counter Data Buffer Low Bytes Register	0xB3	00	6.11
Enhanced Timer/Counter Data Buffer High Bytes Register	0xB4	80	6.11
SPI Control Register 1	0xC0	00	6.12
SPI Control Register 2	0xC1	00	6.12
SPI Interrupt Control Register	0xC2	00	6.12
SPI Interrupt Clear Register	0xC3	00	6.12
SPI Flag Register	0xC4	00	6.12
SPI Bit Rate Setting Register	0xC5	00	6.12
SPI Transmit Buffer Register	0xC6	FF	6.12
SPI Receive Buffer Register	0xC7	00	6.12
ADC Control Register	0xD0	80	6.13
ADC Setting Control Register	0xD1	40	6.13
ADC Interrupt Control Register	0xD2	00	6.13
ADC Channel Control Register	0xD3	00	6.13
ADC Voltage Compare Data High Bytes Register	0xD4	80	6.13
ADC Voltage Compare Data Low Bytes Register	0xD5	00	6.13
ADC Converted Data High Bytes Register	0xD6	00	6.13
ADC Converted Data Low Bytes Register	0xD7	00	6.13
Comparator Control Register	0xDA	E0	6.14
Comparator Flag Register	0xDB	00	6.14
Comparator Reference Voltage Register	0xDC	00	6.14
E <sup>2</sup> PROM Enable Register 1	0xE0	00	6.17
E <sup>2</sup> PROM Enable Register 2	0xE1	00	6.17

<b>Register Name</b>	<b>Address</b>	<b>Reset Default (Hex)</b>	<b>Index Section</b>
E <sup>2</sup> PROM Address Low Bytes Register	0xE2	FF	6.17
E <sup>2</sup> PROM Address High Bytes Register	0xE3	0F	6.17
E <sup>2</sup> PROM Control Register	0xE4	08	6.17
E <sup>2</sup> PROM Data Register	0xE8	00	6.17

## 6.2 I/O Port

### 6.2.1 Features

- ◆ 18 programmable I/O, contains: GPIOA[5:0], GPIOB[5:0], GPIOC[5:0]
- ◆ Some I/O with special functions (such as IRQ, ADC, and PWM exc.), can be configured by Special Function Register

### 6.2.2 Register

WT51F104 I/O related registers are classified into four categories:

- ◆ GPIOx\_OE: Control Output/Input Register, configured to set I/O as output or input. If the corresponding bit GPIOx\_OE = 1, it is an output port with 4mA driving ability
- ◆ GPIOx\_D: Data Register, reading I/O data or set output of I/O
- ◆ GPIOx\_PHN: Internal Pull-up Resistor Enable Register. When I/O is configured as Input port (by GPIOx\_OE), this register is allowed to set if I/O is with pull-up resistor. If the corresponding GPIOx\_PHN bit = 0, the I/O is with internal pull-up resistor.
- ◆ GPIOx\_TYP: Output mode setting Register, is configured to set I/O as Push-Pull or Open Drain type.

#### General-purpose I/O Port A Output Enable Control Register GPIOA\_OE (XFR: 0x10) Reset Value: 00h

Bit	Bit 7	Bit 6	Bit 5	Bit 4	Bit 3	Bit 2	Bit 1	Bit 0
Status			R/W	R/W	R/W	R/W	R/W	R/W
Name	Reserved		GPIOA_OE[5:0]					

Bit Number	Bit Mnemonic	Description
7-6	Reserved	-
5-4	GPIOA_OE[5:4]	General-purpose I/O Port A Output/Input setting 1: Output 0: Input (default)
3	GPIOA_OE[3]	General-purpose I/O Port A Output/Input setting 0: Input (default) <b>Note: Input mode only</b>
2-0	GPIOA_OE[2:0]	General-purpose I/O Port A Output/Input setting 1: Output 0: Input (default)

- : unimplemented.

**General-purpose I/O Port B Output Enable Control Register GPIOB\_OE (XFR: 0x11) Reset Value: 00h**

Bit	Bit 7	Bit 6	Bit 5	Bit 4	Bit 3	Bit 2	Bit 1	Bit 0
Status	-	-	R/W	R/W	R/W	R/W	R/W	R/W
Name	Reserved		GPIOB_OE[5:0]					

Bit Number	Bit Mnemonic	Description
7-6	Reserved	-
5-0	GPIOB_OE[5:0]	General-purpose I/O Port B Output/Input setting 1: Output 0: Input (default)

- : unimplemented.

**General-purpose I/O Port C Output Enable Control Register GPIOC\_OE (XFR: 0x12) Reset Value: 00h**

Bit	Bit 7	Bit 6	Bit 5	Bit 4	Bit 3	Bit 2	Bit 1	Bit 0
Status	-	-	R/W	R/W	R/W	R/W	R/W	R/W
Name	Reserved		GPIOC_OE[5:0]					

Bit Number	Bit Mnemonic	Description
7-6	Reserved	-
5-0	GPIOC_OE[5:0]	General-purpose I/O Port C Output/Input setting 1: Output 0: Input (default)

- : unimplemented.

**General-purpose I/O Port A Data Register GPIOA\_D (XFR: 0x16) Reset Value: 00h**

Bit	Bit 7	Bit 6	Bit 5	Bit 4	Bit 3	Bit 2	Bit 1	Bit 0
Status	-	-	R/W	R/W	R/W	R/W	R/W	R/W
Name	Reserved		GPIOA_D[5:0]					

Bit Number	Bit Mnemonic	Description
7-6	Reserved	-
5-4	GPIOA_D[5:4]	General-purpose I/O Port A Output/Input data
3	GPIOA_D[3]	GPIOA3 is input only pin
2-0	GPIOA_D[2:0]	General-purpose I/O Port A Output/Input data

-: unimplemented.

**General-purpose I/O Port B Data Register GPIOB\_D (XFR: 0x17)**
**Reset Value: 00h**

Bit	Bit 7	Bit 6	Bit 5	Bit 4	Bit 3	Bit 2	Bit 1	Bit 0
Status	-	-	R/W	R/W	R/W	R/W	R/W	R/W
Name	Reserved		GPIOB_D[5:0]					

Bit Number	Bit Mnemonic	Description
7-6	Reserved	-
5-0	GPIOB_D[5:0]	General-purpose I/O Port B Output/Input data

**:- unimplemented.**
**General-purpose I/O Port C Data Register GPIOC\_D (XFR: 0x18)**
**Reset Value: 00h**

Bit	Bit 7	Bit 6	Bit 5	Bit 4	Bit 3	Bit 2	Bit 1	Bit 0
Status	-	-	R/W	R/W	R/W	R/W	R/W	R/W
Name	Reserved		GPIOC_D[5:0]					

Bit Number	Bit Mnemonic	Description
7-6	Reserved	-
5-0	GPIOC_D[5:0]	General-purpose I/O Port C Output/Input data

**:- unimplemented.**
**General-purpose I/O Port A Enable Internal Pull-up Resistor GPIOA\_PHN (XFR: 0x1C) Reset Value: 3Fh**

Bit	Bit 7	Bit 6	Bit 5	Bit 4	Bit 3	Bit 2	Bit 1	Bit 0
Status	-	-	R/W	R/W	R/W	R/W	R/W	R/W
Name	Reserved		GPIOA_PHN[5:0]					

Bit Number	Bit Mnemonic	Description
7-6	Reserved	-
5-0	GPIOA_PHN[5:0]	Enable General-purpose I/O Port A Pull-up Resistor setting 1: Disable Pull-up Resistor (default) 0: Enable Pull-up Resistor

**:- unimplemented.**
**General-purpose I/O Port B Enable Internal Pull-up Resistor GPIOB\_PHN (XFR: 0x1D) Reset Value: 3Fh**

Bit	Bit 7	Bit 6	Bit 5	Bit 4	Bit 3	Bit 2	Bit 1	Bit 0
Status	-	-	R/W	R/W	R/W	R/W	R/W	R/W
Name	Reserved		GPIOB_PHN[5:0]					

Bit Number	Bit Mnemonic	Description
7-6	Reserved	-
5-0	GPIOB_PHN[5:0]	Enable General-purpose I/O Port B Pull-up Resistor setting 1: Disable Pull-up Resistor (default) 0: Enable Pull-up Resistor

:- unimplemented.

**General-purpose I/O Port C Enable Internal Pull-up Resistor GPIOC\_PHN (XFR: 0x1E) Reset Value: 3Fh**

Bit	Bit 7	Bit 6	Bit 5	Bit 4	Bit 3	Bit 2	Bit 1	Bit 0
Status	-	-	R/W	R/W	R/W	R/W	R/W	R/W
Name	Reserved		GPIOC_PHN[5:0]					

Bit Number	Bit Mnemonic	Description
7-6	Reserved	-
5-0	GPIOC_PHN[5:0]	Enable General-purpose I/O Port A Pull-up Resistor setting 1: Disable Pull-up Resistor (default) 0: Enable Pull-up Resistor

:- unimplemented.

**General-purpose I/O Port A Output Type Control Register GPIOA\_TYP (XFR: 0x22) Reset Value: 3Fh**

Bit	Bit 7	Bit 6	Bit 5	Bit 4	Bit 3	Bit 2	Bit 1	Bit 0
Status	-	-	R/W	R/W	-	R/W	R/W	R/W
Name	Reserved		GPIOA_TYP[5:4]		Reserved	GPIOA_TYP[2:0]		

Bit Number	Bit Mnemonic	Description
7-6	Reserved	-
3	Reserved	-
5-4	GPIOA_TYP[5:4]	General-purpose I/O Port A output type setting 1: Push-pull output type (default) 0: Open-drain output type
2-0	GPIOA_TYP[2:0]	

:- unimplemented.

**General-purpose I/O Port B Output Type Control Register GPIOB\_TYP (XFR: 0x23) Reset Value: 3Fh**

Bit	Bit 7	Bit 6	Bit 5	Bit 4	Bit 3	Bit 2	Bit 1	Bit 0
Status	-	-	R/W	R/W	R/W	R/W	R/W	R/W
Name	Reserved		GPIOB_TYP[5:0]					



Bit Number	Bit Mnemonic	Description
7-6	Reserved	-
5-0	GPIOB_TYP[5:0]	General-purpose I/O Port B output type setting 1: Push-pull output type (default) 0: Open-drain output type

-: unimplemented.

**General-purpose I/O Port C Output Type Control Register GPIOC\_TYP (XFR: 0x24)      Reset Value: 3Fh**

Bit	Bit 7	Bit 6	Bit 5	Bit 4	Bit 3	Bit 2	Bit 1	Bit 0
Status	-	-	R/W	R/W	R/W	R/W	R/W	R/W
Name	Reserved		GPIOC_TYP[5:0]					

Bit Number	Bit Mnemonic	Description
7-6	Reserved	-
5-0	GPIOC_TYP[5:0]	General-purpose I/O Port C output type setting 1: Push-pull output type (default) 0: Open-drain output type

-: unimplemented.

### 6.2.3 Port Sharing

This is used to set I/O functions, such as SPI, I<sup>2</sup>C, PWM, ADC, etc.

**General-purpose I/O Port A Complex Function Setting Register1 GPIOA\_FUN1 (XFR: 0x25) Reset Value: 00h**

Bit	Bit 7	Bit 6	Bit 5	Bit 4	Bit 3	Bit 2	Bit 1	Bit 0
Status	-	R/W	R/W	R/W	-	R/W	R/W	R/W
Name	Reserved	GPA5_FUN_SLT[2:0]			Reserved	GPA4_FUN_SLT[2:0]		

Bit Number	Bit Mnemonic	Description
7	Reserved	-
6-4	GPA5_FUN_SLT[2:0]	Set GPIOA5DH complex function 000: GPIO/IRQ15 (default) 001: ADC15 input 011: PWM1 output of Path B 010: T1 input 101: P00 output/input (mapping to 8052 P0.0) <b>Note: If GPIOA4DH = OCSO, GPIOA5DH must be set as GPIO.</b>
3	Reserved	-
2-0	GPA4_FUN_SLT[2:0]	Set GPIOA4DH complex function 000: GPIO/IRQ14/ETMIA (default) 001: ADC14 input 010: OSCO ( <b>select OSCO, and the mapping GPIOA5DH must be set as GPIO</b> ) 011: PWM0 output of Path B 101: P01 output/input (mapping to 8052 P0.1)

:- unimplemented.

**Note:** Before using the external input pins (ETMIA & ETMIB) of the Enhanced Timer/Counter, please set GPIOA5/GPIOA4 as input mode GPIO.

**Note:** The setting of using External Crystal Oscillator as SOURCE clock:

1. Set GPIOA5 and GPIOA4 as Input port. (XFR 0x10 GPIOA\_OE[5:4])
2. GPIOA5 and GPIOA4 disable internal pull high resistor. If enable pull high resistor will result in oscillator outputs unstable frequency. (XFR 0x1C GPIOA\_PHN[5:4])
3. Set GPIOA4 as OSCO crystal oscillator pin. (XFR 0x25 GPA4\_FUN\_SLT[2:0])
4. Set the complex function of GPIOA5 as GPIO. (XFR 0x25 GPA5\_FUN\_SLT[2:0])
5. Set the driving ability of External Crystal Oscillator. (XFR 0x08 CRY\_12M\_DR[1:0])
6. Power on External Crystal Oscillator switch. (XFR 0x07 CRY\_12M\_PD)
7. Switch SOURCE clock to External Crystal Oscillator. (XFR 0x05 SOURCE\_CLK\_SLT[1:0])

**Note:** While using 8052 port (P0.x), please set the mapping rGPIO\_TYP as open drain and connect to external pull-up resistor.

**General-purpose I/O Port A Complex Function Setting Register2 GPIOA\_FUN2 (XFR: 0x26)      Reset Value: 00h**

Bit	Bit 7	Bit 6	Bit 5	Bit 4	Bit 3	Bit 2	Bit 1	Bit 0
Status	-	R/W	R/W	R/W	-	R/W	R/W	R/W
Name	Reserved	GPA3_FUN_SLT[2:0]			Reserved	GPA2_FUN_SLT[2:0]		

Bit Number	Bit Mnemonic	Description
7	Reserved	-
6-4	GPA3_FUN_SLT[2:0]	Set GPA3D complex function 000: GPIO/IRQ13/ETMIB (default) 001: ADC13 input 010: Reset pin (NRST) input
3	Reserved	-
2-0	GPA2_FUN_SLT[2:0]	Set GPIOA2DH complex function 000: GPIO/IRQ2 (default) 001: ADC2 input 010: CMPO, Comparator output 011: PWM1 output of Path C 101: T0 input

-: unimplemented.

**General-purpose I/O Port A Complex Function Setting Register3 GPIOA\_FUN3 (XFR: 0x27)      Reset Value: 00h**

Bit	Bit 7	Bit 6	Bit 5	Bit 4	Bit 3	Bit 2	Bit 1	Bit 0
Status	-	R/W	R/W	R/W	-	R/W	R/W	R/W
Name	Reserved	GPA1_FUN_SLT[2:0]			Reserved	GPA0_FUN_SLT[2:0]		

Bit Number	Bit Mnemonic	Description
7	Reserved	-
6-4	GPA1_FUN_SLT[2:0]	Set GPIOA1DH complex function 000: GPIO/IRQ1 (default) 001: ADC1 input or VREF input 010: CMPN, Comparator Negative Input pin 100: RX0B, RX of Path B of UART0 101: I <sup>2</sup> C SCL input/output pin 110: SCK pin of Path A of SPI 111: MISO data pin of Path B of SPI  <b>Note: ADC1 input can be selected by EN_AD[3:0] of ADC Channel Control Register; while VREF input can be selected by ADC_VREF_SEL[1:0] of ADC Setting Control Register.</b>
3	Reserved	-
2-0	GPA0_FUN_SLT[2:0]	Set GPIOA0DH complex function 000: GPIO/IRQ0 (default) 001: ADC0 input 010: CMPP, Comparator Positive Input pin 011: PWM0 output of Path C 100: TX0B, TX of Path B of UART0 101: I <sup>2</sup> C SDA input/output pin

Bit Number	Bit Mnemonic	Description
		110: MISO pin of Path A of SPI 111: SCK data pin of Path B of SPI <b>Note: If GPIOA1DH = I<sup>2</sup>C SCL, GPIOA0DH must be set as GPIO.</b>

**Note: While using UART0 path B, I<sup>2</sup>C, please set the mapping rGPIO\_TYP as open drain and connect to external pull-up resistor.**

**General-purpose I/O Port B Complex Function Setting Register1 GPIOB\_FUN1 (XFR: 0x28)      Reset Value: 00h**

Bit	Bit 7	Bit 6	Bit 5	Bit 4	Bit 3	Bit 2	Bit 1	Bit 0
Status	-	R/W	R/W	R/W	-	R/W	R/W	R/W
Name	Reserved	GPB5_FUN_SLT[2:0]			Reserved	GPB4_FUN_SLT[2:0]		

Bit Number	Bit Mnemonic	Description
7	Reserved	-
6-4	GPB5_FUN_SLT[2:0]	Set GPIOB5 complex function 000: GPIO/IRQ12 (default) 001: ADC12 input 010: RX0A, RX of Path A of UART0 011: PWM1 output of Path A 101: P02 output/input (mapping to 8052 P0.2)
3	Reserved	-
2-0	GPB4_FUN_SLT[2:0]	Set GPIOB4 complex function 000: GPIO/IRQ11 (default) 001: ADC11 input 010: TX0A, TX of Path A of UART0 011: PWM1 output of Path D 101: P03 output/input (mapping to 8052 P0.3) <b>Note: If GPIOB5 = RX0A, GPB4_FUN_SLT will auto select TX0A, and the complex function of ADC11/PWM1D will be invalid.</b>

-: unimplemented.

**Note 1: While using 8052 port (P0.x), please set the mapping rGPIO\_TYP as open drain and connect to external pull-up resistor.**

**Note 2: While using UART0 path A, please set the mapping rGPIO\_TYP as open drain and connect to external pull-up resistor.**

**General-purpose I/O Port B Complex Function Setting Register2 GPIOB\_FUN2 (XFR: 0x29)      Reset Value: 00h**

Bit	Bit 7	Bit 6	Bit 5	Bit 4	Bit 3	Bit 2	Bit 1	Bit 0
Status	-	R/W	R/W	R/W	-	R/W	R/W	R/W
Name	Reserved	GPB3_FUN_SLT[2:0]			Reserved	GPB2_FUN_SLT[2:0]		

Bit Number	Bit Mnemonic	Description
7	Reserved	-
6-4	GPB3_FUN_SLT[2:0]	Set GPIOB3 complex function

Bit Number	Bit Mnemonic	Description
		000: GPIO/IRQ10 (default) 001: ADC10 input 011: PWM0 output of Path A
3	Reserved	-
2-0	GPB2_FUN_SLT[2:0]	Set GPIOB2 complex function 000: GPIO/IRQ5 (default) 001: ADC5 input 010: STB pin of SPI 011: PWM0 output of Path D

:- unimplemented.

**General-purpose I/O Port B Complex Function Setting Register3 GPIOB\_FUN3 (XFR: 0x2A)      Reset Value: 00h**

Bit	Bit 7	Bit 6	Bit 5	Bit 4	Bit 3	Bit 2	Bit 1	Bit 0
Status	-	R/W	R/W	R/W	-	R/W	R/W	R/W
Name	Reserved	GPB1_FUN_SLT[2:0]			Reserved	GPB0_FUN_SLT[2:0]		

Bit Number	Bit Mnemonic	Description
7	Reserved	-
6-4	GPB1_FUN_SLT[2:0]	Set GPIOB1 complex function 000: GPIO/IRQ4 (default) 001: ADC4 input 010: MOSI pin of SPI
3	Reserved	-
2-0	GPB0_FUN_SLT[2:0]	Set GPIOB0 complex function 000: GPIO/IRQ3 (default) 001: ADC3 input

:- unimplemented.

**General-purpose I/O Port C Complex Function Setting Register1 GPIOC\_FUN1 (XFR: 0x2B)      Reset Value: 00h**

Bit	Bit 7	Bit 6	Bit 5	Bit 4	Bit 3	Bit 2	Bit 1	Bit 0
Status	-	R/W	R/W	R/W	-	R/W	R/W	R/W
Name	Reserved	GPC5_FUN_SLT[2:0]			Reserved	GPC4_FUN_SLT[2:0]		

Bit Number	Bit Mnemonic	Description
7	Reserved	-
6-4	GPC5_FUN_SLT[2:0]	Set GPIOC5 complex function 000: GPIO/IRQ9 (default) 001: ADC9 input
3	Reserved	-
2-0	GPC4_FUN_SLT[2:0]	Set GPIOC4 complex function 000: GPIO/IRQ8 (default) 001: ADC8 input

:- unimplemented.

**General-purpose I/O Port C Complex Function Setting Register2 GPIOC\_FUN2 (XFR: 0x2C)      Reset Value: 00h**

Bit	Bit 7	Bit 6	Bit 5	Bit 4	Bit 3	Bit 2	Bit 1	Bit 0
Status	-	R/W	R/W	R/W	-	R/W	R/W	R/W
Name	Reserved	GPC3_FUN_SLT[2:0]			Reserved	GPC2_FUN_SLT[2:0]		

Bit Number	Bit Mnemonic	Description
7	Reserved	-
6-4	GPC3_FUN_SLT[2:0]	Set GPIOC3 complex function 000: GPIO (default)
3	Reserved	-
2-0	GPC2_FUN_SLT[2:0]	Set GPIOC2 complex function 000: GPIO (default)

:- unimplemented.

**General-purpose I/O Port C Complex Function Setting Register3 GPIOC\_FUN3 (XFR: 0x2D)      Reset Value: 00h**

Bit	Bit 7	Bit 6	Bit 5	Bit 4	Bit 3	Bit 2	Bit 1	Bit 0
Status	-	R/W	R/W	R/W	-	R/W	R/W	R/W
Name	Reserved	GPC1_FUN_SLT[2:0]			Reserved	GPC0_FUN_SLT[2:0]		

Bit Number	Bit Mnemonic	Description
7	Reserved	-
6-4	GPC1_FUN_SLT[2:0]	Set GPIOC1 complex function 000: GPIO/IRQ7 (default) 001: ADC7 input
3	Reserved	-
2-0	GPC0_FUN_SLT[2:0]	Set GPIOC0 complex function 000: GPIO/IRQ6 (default) 001: ADC6 input

:- unimplemented.

**ADC Complex Function Setting Table:**

ADC	Register Setting	Shared with GPIO
ADC15	GPA5_FUN_SLT[2:0] = 001	GPIOA5
ADC14	GPA4_FUN_SLT[2:0] = 001	GPIOA4
ADC13	GPA3_FUN_SLT[2:0] = 001	GPIOA3
ADC12	GPB5_FUN_SLT[2:0] = 001	GPIOB5
ADC11	GPB4_FUN_SLT[2:0] = 001	GPIOB4
ADC10	GPB3_FUN_SLT[2:0] = 001	GPIOB3
ADC9	GPC5_FUN_SLT[2:0] = 001	GPIOC5

ADC	Register Setting	Shared with GPIO
ADC8	GPC4_FUN_SLT[2:0] = 001	GPIOC4
ADC7	GPC1_FUN_SLT[2:0] = 001	GPIOC1
ADC6	GPC0_FUN_SLT[2:0] = 001	GPIOC0
ADC5	GPB2_FUN_SLT[2:0] = 001	GPIOB2
ADC4	GPB1_FUN_SLT[2:0] = 001	GPIOB1
ADC3	GPB0_FUN_SLT[2:0] = 001	GPIOB0
ADC2	GPA2_FUN_SLT[2:0] = 001	GPIOA2
ADC1	GPA1_FUN_SLT[2:0] = 001	GPIOA1
ADC0	GPA0_FUN_SLT[2:0] = 001	GPIOA0

**ADC VREF Complex Function Setting Table:**

ADC VREF	Register Setting	Shared with GPIO
VREF	GPA1_FUN_SLT[2:0] = 001	GPIOA1

**Crystal Oscillator Complex Function Setting Table:**

CLKIO	Register Setting	Shared with GPIO
OSCO	GPA4_FUN_SLT[2:0] = 010	GPIOA4
OSCI	GPA4_FUN_SLT[2:0] = 010	GPIOA5

**SPI Complex Function Setting Table**

SPI	Register Setting	Shared with GPIO
STB	GPB2_FUN_SLT[2:0] = 010	GPIOB2
SCKA	GPA1_FUN_SLT[2:0] = 110	GPIOA1
SCKB	GPA0_FUN_SLT[2:0] = 111	GPIOA0
MOSI	GPB1_FUN_SLT[2:0] = 010	GPIOB1
MISOA	GPA0_FUN_SLT[2:0] = 110	GPIOA0
MISOB	GPA1_FUN_SLT[2:0] = 111	GPIOA1

**UART Complex Function Setting Table:**

UART	Register Setting	Shared with GPIO
RX0A	GPIOB_OE[5] = 0 GPIOB_TYP[5] = 0 GPB5_FUN_SLT[2:0] = 010	GPIOB5
TX0A	GPIOB_OE[4] = 1 GPIOB_TYP[4] = 0 GPB4_FUN_SLT[2:0] = 010	GPIOB4

UART	Register Setting	Shared with GPIO
RX0B	GPIOA_OE[1] = 0 GPIOA_TYP[1] = 0 GPA1_FUN_SLT[2:0] = 100	GPIOA1
TX0B	GPIOA_OE[0] = 1 GPIOA_TYP[0] = 0 GPA0_FUN_SLT[2:0] = 100	GPIOA0

**I<sup>2</sup>C Complex Function Setting Table:**

Master I <sup>2</sup> C	Register Setting	Shared with GPIO
SDA	GPIOA_OE[0] = 1 GPIOA_TYP[0] = 0 GPA0_FUN_SLT[2:0] = 101	GPIOA0
SCL	GPIOA_OE[1] = 1 GPIOA_TYP[1] = 0 GPA1_FUN_SLT[2:0] = 101	GPIOA1

Slave I <sup>2</sup> C	Register Setting	Shared with GPIO
SDA	GPIOA_OE[0] = 0 GPIOA_TYP[0] = 0 GPA0_FUN_SLT[2:0] = 101	GPIOA0
SCL	GPIOA_OE[1] = 0 GPIOA_TYP[1] = 0 GPA1_FUN_SLT[2:0] = 101	GPIOA1

**Comparator Complex Function Setting Table:**

ACOM	Register Setting	Shared with GPIO
COMPP	GPA0_FUN_SLT[2:0] = 010	GPIOA0
COMPN	GPA1_FUN_SLT[2:0] = 010	GPIOA1
COMPO	GPA2_FUN_SLT[2:0] = 010	GPIOA2

**Timer0/1 Pin Setting Table:**

Timer0/1	Register Setting	Shared with GPIO
T0	GPA2_FUN_SLT[2:0] = 101	GPIOA2
T1	GPA5_FUN_SLT[2:0] = 010	GPIOA5



**PWM0 Complex Function Setting Table:**

PWM0	Register Setting	Shared with GPIO
PWM0A	GPB3_FUN_SLT[2:0] = 011	GPIOB3
PWM0B	GPA4_FUN_SLT[1:0] = 011	GPIOA4
PWM0C	GPA0_FUN_SLT[1:0] = 010	GPIOA0
PWM0D	GPB2_FUN_SLT[1:0] = 011	GPIOB2

**PWM1 Complex Function Setting Table:**

PWM1	Register Setting	Shared with GPIO
PWM1A	GPB5_FUN_SLT[2:0] = 011	GPIOB5
PWM1B	GPA5_FUN_SLT[2:0] = 011	GPIOA5
PWM1C	GPA2_FUN_SLT[1:0] = 011	GPIOA2
PWM1D	GPB4_FUN_SLT[2:0] = 011	GPIOB4

**8052 Port 0 Complex Function Setting Table:**

8052 Port 0.x	Register Setting	Shared with GPIO
P0.0	GPA5_FUN_SLT[2:0] = 101	GPIOA5
P0.1	GPA4_FUN_SLT[2:0] = 101	GPIOA4
P0.2	GPB5_FUN_SLT[2:0] = 101	GPIOB5
P0.3	GPB4_FUN_SLT[2:0] = 101	GPIOB4

### 6.3 Interrupt

The WT51F104 provides total seven 8052 Interrupt sources: four 8052 External Interrupts (INT0, INT1, INT2, INT3), two Timer/Counter Interrupts (TF0, TF1), and one UART Interrupt (RI0/TI0).

Each of these interrupt sources has its own enable control bit, and can be individually enabled or disabled by setting or clearing the corresponding bit in the Special Function Register IE0 or XICON.

When an interrupt is generated, CPU will jump to interrupt vector from service routine as listed below. If multiple requests of different priority levels are received simultaneously, the request of higher priority level is serviced, and then returned to service routine through RETI instruction. If interrupt flag bit is set, CPU will enter the Interrupt processing again.

#### Interrupt Vector Table of 8052 & Priority Level Structure:

Keil C Interrupt Number	Interrupt sources	Vector Address	Priority Level (default)	Interrupt Enable Register
0	8052 external interrupt 0	03H	1	IE.0 (EX0)
1	Timer/Counter 0 interrupt	0BH	2	IE.1 (ET0)
2	8052 external interrupt 1	13H	3	IE.2 (EX1)
3	Timer/Counter 1 interrupt	1BH	4	IE.3 (ET1)
4	Serial port 0 interrupt (UART0)	23H	5	IE.4 (ES)
7	8052 external interrupt 2	3BH	6	XICON.2 (EX2)
8	8052 external interrupt 3	43H	7	XICON.6 (EX3)

#### Interrupt Enable Register 0

**IE (8052 interrupt enable register, including INT0/INT1) Address: A8H**

**Reset Value: 00h**

7	6	5	4	3	2	1	0
EA	ES1	ET2	ES	ET1	EX1	ET0	EX0

Bit Number	Bit Mnemonic	Description
7	EA	1: Enable all interrupt function 0: Disable all interrupt function
6	ES1	1: Enable UART 1 interrupt (function not available in WT51F104) 0: Disable UART 1 interrupt
5	ET2	1: Enable Timer/Counter 2 interrupt (function not available in WT51F104) 0: Disable Timer/Counter 2 interrupt
4	ES	1: Enable UART 0 interrupt 0: Disable UART 0 interrupt
3	ET1	1: Enable Timer/Counter 1 interrupt 0: Disable Timer/Counter 1 interrupt

Bit Number	Bit Mnemonic	Description
2	EX1	1: Enable 8052 external interrupt 1 interrupt 0: Disable 8052 external interrupt 1 interrupt
1	ET0	1: Enable Timer/Counter 0 interrupt 0: Disable Timer/Counter 0 interrupt
0	EX0	1: Enable 8052 external interrupt 0 interrupt 0: Disable 8052 external interrupt 0 interrupt

**Interrupt Enable Register 1**
**XICON (8052 interrupt enable register, including INT2/INT3) Address: C0H**
**Reset Value: 00h**

7	6	5	4	3	2	1	0
PX3	EX3	IE3	-	PX2	EX2	IE2	-

Bit Number	Bit Mnemonic	Description
7	PX3	Define the interrupt priority of external interrupt 3 1: INT3 has the higher priority 0: INT3 has the lower priority
6	EX3	1: Enable external interrupt 3 interrupt 0: Disable external interrupt 3 interrupt
5	IE3	If CPU detects external interrupt 3 interrupt, IE3 will be cleared by hardware 1: Has external interrupt 3 request 0: No external interrupt 3 request
4	Reserved	-
3	PX2	Define the interrupt priority of external interrupt 2 1: INT2 has the higher priority 0: INT2 has the lower priority
2	EX2	1: Enable external interrupt 2 interrupt 0: Disable external interrupt 2 interrupt
1	IE2	If CPU detects external interrupt 2 interrupt, IE2 will be cleared by hardware 1: Has external interrupt 2 request 0: No external interrupt 2 request
0	Reserved	-

**-: unimplemented.**

**Interrupt priority register**
**IP (8052 interrupt priority register) Address: B8H**
**Reset Value: 00h**

7	6	5	4	3	2	1	0
-	PS1	PT2	PS	PT1	PX1	PT0	PX0

Bit Number	Bit Mnemonic	Description
7	Reserved	-
6	PS1	Define the interrupt priority of UART 1 1: Has the higher priority 0: Has the lower priority
5	PT2	Define the interrupt priority of Timer/Counter2 1: Has the higher priority 0: Has the lower priority
4	PS	Define the interrupt priority of UART 0 1: Has the higher priority 0: Has the lower priority
3	PT1	Define the interrupt priority of Timer/Counter 1 1: Has the higher priority 0: Has the lower priority
2	PX1	Define the interrupt priority of external interrupt 1 1: Has the higher priority 0: Has the lower priority
1	PT0	Define the interrupt priority of Timer/Counter 0 1: Has the higher priority 0: Has the lower priority
0	PX0	Define the interrupt priority of external interrupt 0 1: Has the higher priority 0: Has the lower priority

**:- unimplemented.**

As illustrated below, if not set the priority level in Interrupt Priority Register (IP), the priority level of interrupt will be: **INT0 > T0 > INT1 > T1 > UART0 > T2 > UART1 > INT2 > INT3**.

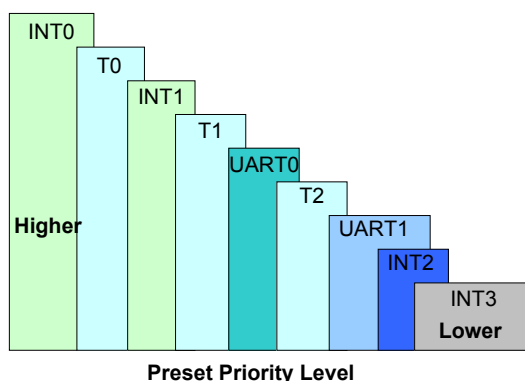

If the higher priority is assigned to any one of the interrupts, such as set PT1 = 1, then the priority level will be: **T1 > INT0 > T0 > INT1 > UART0 > T2 > UART1 > INT2 > INT3**.

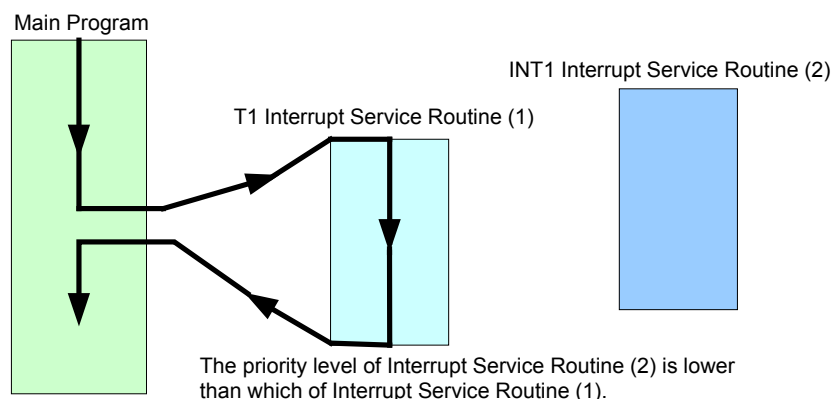

If PT1 = 1 and PX1 = 1, then the priority level will be: **INT1 > T1 > INT0 > T0 > UART0 > T2 > UART1 > INT2 > INT3**, and so on. The figure below illustrated the executing procedures under different priority levels.

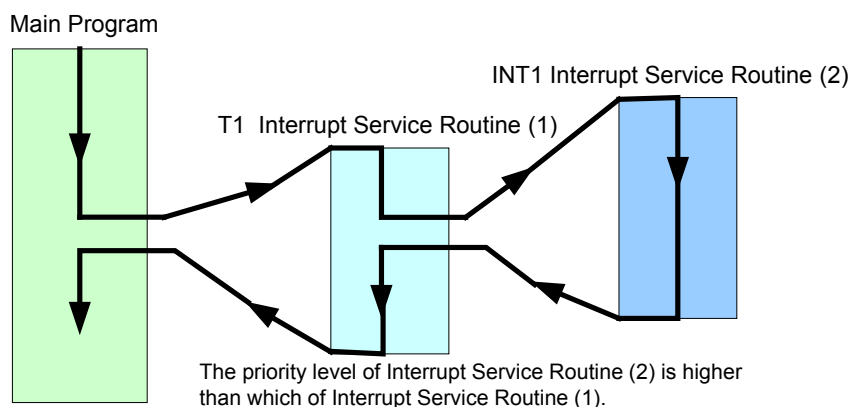

### 6.3.1 8052 External Interrupt 0/1/2

The WT51F104 supports eight peripheral interrupt sources which are derived from 8052 external interrupt 0/1/2, as described below.

1. SPI interrupt
2. I<sup>2</sup>C interrupt
3. ADC interrupt
4. Comparator (ACOMP) interrupt
5. Low Voltage Detection (LVD) interrupt
6. Watch Timer interrupt
7. Enhanced Timer/Counter interrupt
8. General-purpose I/O port input triggered interrupt

The figure below shows the interrupt sources of 8052 external interrupt 0/1/2:

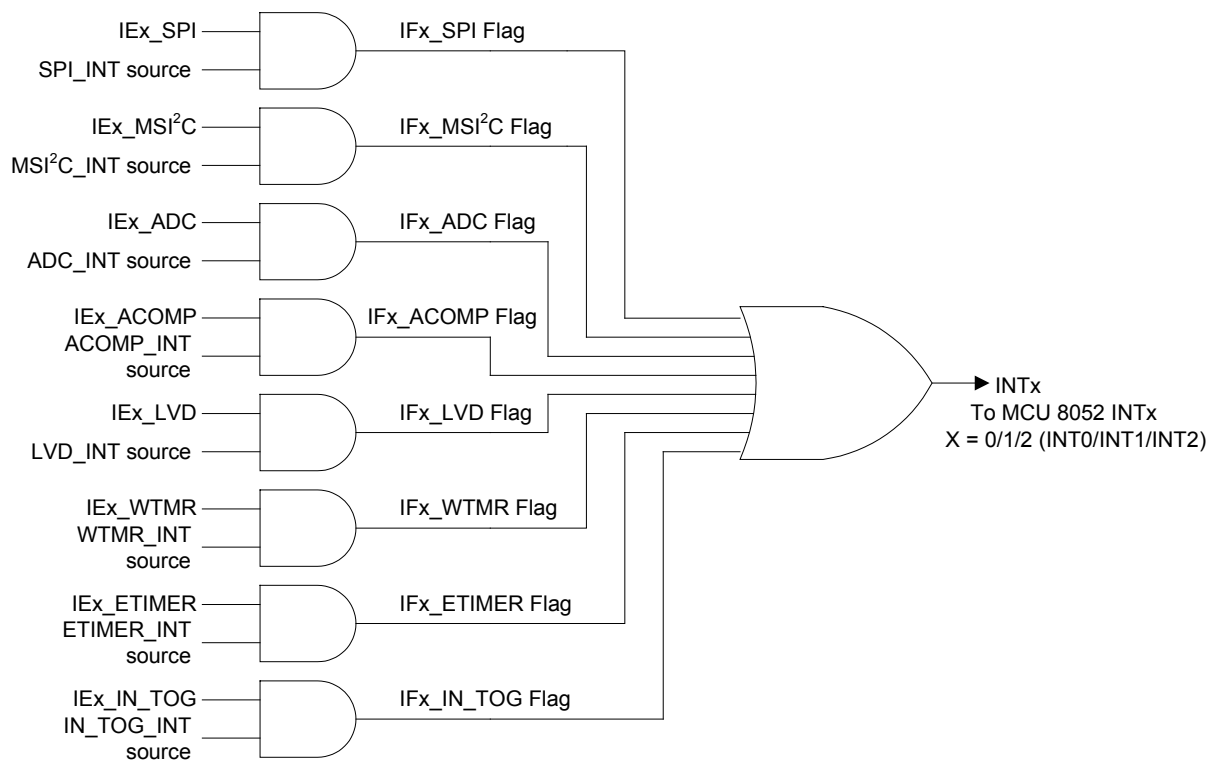

### 6.3.2 8052 External Interrupt 3

WT51F104 contains 16 External Interrupt Request input pins. An interrupt is generated by using 8052 External Interrupt Vector 3, as illustrated below (refer to section 6.5 for more details).

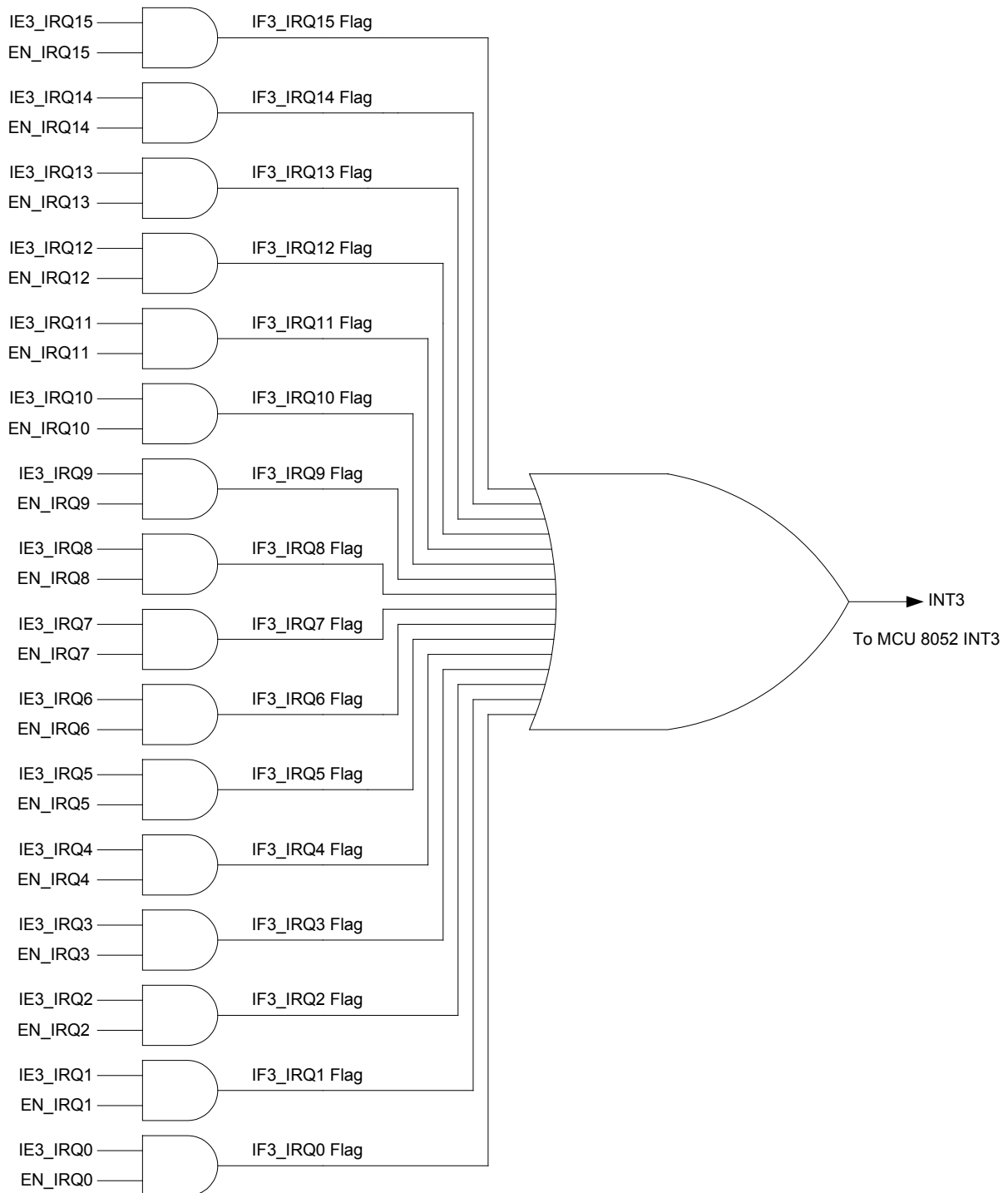

**8052 External Interrupt 0 Control Register IE0\_CTL (XFR: 0x30)**
**Reset Value: 00h**

Bit	Bit 7	Bit 6	Bit 5	Bit 4	Bit 3	Bit 2	Bit 1	Bit 0
Status	R/W	R/W	R/W	R/W	R/W	R/W	R/W	R/W
Name	IE0_SPI	IE0_MSI <sup>2</sup> C	IE0_ADC	IE0_ACOMP	IE0_LVD	IE0_WTMR	IE0_ETIMER	IE0_IN_TOG

Bit Number	Bit Mnemonic	Description
7	IE0_SPI	1: Enable SPI Interrupt generated by INT0 0: Disable SPI Interrupt generated by INT0
6	IE0_MSI <sup>2</sup> C	1: Enable M/S I <sup>2</sup> C Interrupt generated by INT0 0: Disable M/S I <sup>2</sup> C Interrupt generated by INT0
5	IE0_ADC	1: Enable ADC Interrupt generated by INT0 0: Disable ADC Interrupt generated by INT0
4	IE0_ACOMP	1: Enable ACOMP Interrupt generated by INT0 0: Disable ACOMP Interrupt generated by INT0
3	IE0_LVD	1: Enable LVD Interrupt generated by INT0 0: Disable LVD Interrupt generated by INT0
2	IE0_WTMR	1: Enable Watch Timer Interrupt generated by INT0 0: Disable Watch Timer Interrupt generated by INT0
1	IE0_ETIMER	1: Enable Enhanced Timer Interrupt generated by INT0 0: Disable Enhanced Timer Interrupt generated by INT0
0	IE0_IN_TOG	1: Enable All-Input Toggle Interrupt generated by INT0 0: Disable All-Input Toggle Interrupt generated by INT0

**8052 External Interrupt 1 Control Register IE1\_CTL (XFR: 0x31)**
**Reset Value: 00h**

Bit	Bit 7	Bit 6	Bit 5	Bit 4	Bit 3	Bit 2	Bit 1	Bit 0
Status	R/W	R/W	R/W	R/W	R/W	R/W	R/W	R/W
Name	IE1_SPI	IE1_MSI <sup>2</sup> C	IE1_ADC	IE1_ACOMP	IE1_LVD	IE1_WTMR	IE1_ETIMER	IE1_IN_TOG

Bit Number	Bit Mnemonic	Description
7	IE1_SPI	1: Enable SPI Interrupt generated by INT1 0: Disable SPI Interrupt generated by INT1
6	IE1_MSI <sup>2</sup> C	1: Enable M/S I <sup>2</sup> C Interrupt generated by INT1 0: Disable M/S I <sup>2</sup> C Interrupt generated by INT1
5	IE1_ADC	1: Enable ADC Interrupt generated by INT1 0: Disable ADC Interrupt generated by INT1
4	IE1_ACOMP	1: Enable ACOMP Interrupt generated by INT1 0: Disable ACOMP Interrupt generated by INT1
3	IE1_LVD	1: Enable LVD Interrupt generated by INT1 0: Disable LVD Interrupt generated by INT1
2	IE1_WTMR	1: Enable Watch Timer Interrupt generated by INT1 0: Disable Watch Timer Interrupt generated by INT1
1	IE1_ETIMER	1: Enable Enhanced Timer Interrupt generated by INT1 0: Disable Enhanced Timer Interrupt generated by INT1
0	IE1_IN_TOG	1: Enable All-Input Toggle Interrupt generated by INT1 0: Disable All-Input Toggle Interrupt generated by INT1



**8052 External Interrupt 2 Control Register IE2\_CTL (XFR: 0x32)**
**Reset Value: 00h**

Bit	Bit 7	Bit 6	Bit 5	Bit 4	Bit 3	Bit 2	Bit 1	Bit 0
Status	R/W	R/W	R/W	R/W	R/W	R/W	R/W	R/W
Name	IE2_SPI	IE2_MSI <sup>2</sup> C	IE2_ADC	IE2_ACOMP	IE2_LVD	IE2_WTMR	IE2_ETIMER	IE2_IN_TOG

Bit Number	Bit Mnemonic	Description
7	IE2_SPI	1: Enable SPI Interrupt generated by INT2 0: Disable SPI Interrupt generated by INT2
6	IE2_MSI <sup>2</sup> C	1: Enable M/S I <sup>2</sup> C Interrupt generated by INT2 0: Disable M/S I <sup>2</sup> C Interrupt generated by INT2
5	IE2_ADC	1: Enable ADC Interrupt generated by INT2 0: Disable ADC Interrupt generated by INT2
4	IE2_ACOMP	1: Enable ACOMP Interrupt generated by INT2 0: Disable ACOMP Interrupt generated by INT2
3	IE2_LVD	1: Enable LVD Interrupt generated by INT2 0: Disable LVD Interrupt generated by INT2
2	IE2_WTMR	1: Enable Watch Timer Interrupt generated by INT2 0: Disable Watch Timer Interrupt generated by INT2
1	IE2_ETIMER	1: Enable Enhanced Timer Interrupt generated by INT2 0: Disable Enhanced Timer Interrupt generated by INT2
0	IE2_IN_TOG	1: Enable All-Input Toggle Interrupt generated by INT2 0: Disable All-Input Toggle Interrupt generated by INT2

**8052 External Interrupt 3 Control High Bytes Register INT3\_IRQ[15:8] (XFR: 0x33)**
**Reset Value: 00h**

Bit	Bit 7	Bit 6	Bit 5	Bit 4	Bit 3	Bit 2	Bit 1	Bit 0
Status	R/W	R/W	R/W	R/W	R/W	R/W	R/W	R/W
Name	IE3_IRQ[15:8]							

Bit Number	Bit Mnemonic	Description
7	IE3_IRQ15	1: Enable IRQ15 Interrupt generated by INT3 0: Disable IRQ15 Interrupt generated by INT3
6	IE3_IRQ14	1: Enable IRQ14 Interrupt generated by INT3 0: Disable IRQ14 Interrupt generated by INT3
5	IE3_IRQ13	1: Enable IRQ13 Interrupt generated by INT3 0: Disable IRQ13 Interrupt generated by INT3
4	IE3_IRQ12	1: Enable IRQ12 Interrupt generated by INT3 0: Disable IRQ12 Interrupt generated by INT3
3	IE3_IRQ11	1: Enable IRQ11 Interrupt generated by INT3 0: Disable IRQ11 Interrupt generated by INT3
2	IE3_IRQ10	1: Enable IRQ10 Interrupt generated by INT3 0: Disable IRQ10 Interrupt generated by INT3
1	IE3_IRQ9	1: Enable IRQ9 Interrupt generated by INT3 0: Disable IRQ9 Interrupt generated by INT3
0	IE3_IRQ8	1: Enable IRQ8 Interrupt generated by INT3 0: Disable IRQ8 Interrupt generated by INT3

**8052 External Interrupt 3 Control Low Bytes Register INT3\_IRQ[7:0] (XFR: 0x34)**
**Reset Value: 00h**

Bit	Bit 7	Bit 6	Bit 5	Bit 4	Bit 3	Bit 2	Bit 1	Bit 0
Status	R/W	R/W	R/W	R/W	R/W	R/W	R/W	R/W
Name	IE3_IRQ[7:0]							

Bit Number	Bit Mnemonic	Description
7	IE3_IRQ7	1: Enable IRQ7 Interrupt generated by INT3 0: Disable IRQ7 Interrupt generated by INT3
6	IE3_IRQ6	1: Enable IRQ6 Interrupt generated by INT3 0: Disable IRQ6 Interrupt generated by INT3
5	IE3_IRQ5	1: Enable IRQ5 Interrupt generated by INT3 0: Disable IRQ5 Interrupt generated by INT3
4	IE3_IRQ4	1: Enable IRQ4 Interrupt generated by INT3 0: Disable IRQ4 Interrupt generated by INT3
3	IE3_IRQ3	1: Enable IRQ3 Interrupt generated by INT3 0: Disable IRQ3 Interrupt generated by INT3
2	IE3_IRQ2	1: Enable IRQ2 Interrupt generated by INT3 0: Disable IRQ2 Interrupt generated by INT3
1	IE3_IRQ1	1: Enable IRQ1 Interrupt generated by INT3 0: Disable IRQ1 Interrupt generated by INT3
0	IE3_IRQ0	1: Enable IRQ0 Interrupt generated by INT3 0: Disable IRQ0 Interrupt generated by INT3

**8052 External Interrupt 0 (INT0) Flag Register IF0\_FLAG (XFR: 0x35)**
**Reset Value: 00h**

Bit	Bit 7	Bit 6	Bit 5	Bit 4	Bit 3	Bit 2	Bit 1	Bit 0
Status	R	R	R	R	R	R	R	R
Name	IF0_SPI	IF0_MSI <sup>2</sup> C	IF0_ADC	IF0_ACOMP	IF0_LVD	IF0_WTMR	IF0_ETIMER	IF0_IN_TOG

Bit Number	Bit Mnemonic	Description
7	IF0_SPI	1: SPI Interrupt Event Flag be set, SPI Interrupt Flag Clear, refer to section 6.12 XFR[0xC3]
6	IF0_MSI <sup>2</sup> C	1: M/S I <sup>2</sup> C Interrupt Event Flag be set, M/S I <sup>2</sup> C Interrupt Flag Clear, refer to section 6.10 XFR[0xA0]
5	IF0_ADC	1: ADC Interrupt Event Flag be set, will be cleared automatically after ADC conversion
4	IF0_ACOMP	1: ACOMP Interrupt Event Flag be set, ACOMP Interrupt Flag Clear, refer to section 6.14 XFR[0xDB]
3	IF0_LVD	1: LVD Interrupt Event Flag be set, LVD Interrupt Flag Clear, refer to section 6.16 XFR[0x03]
2	IF0_WTMR	1: Watch Timer Interrupt Event Flag be set, Watch Timer Interrupt Flag Clear, refer to section 6.9 XFR[0x7C]
1	IF0_ETIMER	1: Enhanced Timer Interrupt Event Flag be set, Enhanced Timer Interrupt Flag Clear, refer to section 6.11 XFR[0xB2]
0	IF0_IN_TOG	1: All-Input Toggle Interrupt Event Flag be set, Input Toggle Interrupt Clear, refer to section 6.7 XFR[0x6A]

**8052 External Interrupt 1 (INT1) Flag Register IF1\_FLAG (XFR: 0x36)**
**Reset Value: 00h**

Bit	Bit 7	Bit 6	Bit 5	Bit 4	Bit 3	Bit 2	Bit 1	Bit 0
Status	R	R	R	R	R	R	R	R
Name	IF1_SPI	IF1_MSI <sup>2</sup> C	IF1_ADC	IF1_ACOMP	IF1_LVD	IF1_WTMR	IF1_ETIMER	IF1_IN_TOG

Bit Number	Bit Mnemonic	Description
7	IF1_SPI	1: SPI Interrupt Event Flag be set, SPI Interrupt Flag Clear, refer to section 6.12 XFR[0xC3]
6	IF1_MSI <sup>2</sup> C	1: M/S I <sup>2</sup> C Interrupt Event Flag be set, M/S I <sup>2</sup> C Interrupt Flag Clear, refer to section 6.10 XFR[0xA0]
5	IF1_ADC	1: ADC Interrupt Event Flag be set, will be cleared automatically after ADC conversion
4	IF1_ACOMP	1: ACOMP Interrupt Event Flag be set, ACOMP Interrupt Flag Clear, refer to section 6.14 XFR[0xDB]
3	IF1_LVD	1: LVD Interrupt Event Flag be set, LVD Interrupt Flag Clear, refer to section 6.16 XFR[0x03]
2	IF1_WTMR	1: Watch Timer Interrupt Event Flag be set, Watch Timer Interrupt Flag Clear, refer to section 6.9 XFR[0x7C]
1	IF1_ETIMER	1: Enhanced Timer Interrupt Event Flag be set, Enhanced Timer Interrupt Flag Clear, refer to section 6.11 XFR[0xB2]
0	IF1_IN_TOG	1: All-Input Toggle Interrupt Event Flag be set, Input Toggle Interrupt Flag Clear, refer to section 6.7 XFR[0x6A]

**8052 External Interrupt 2 (INT2) Flag Register IF2\_FLAG (XFR: 0x37)**
**Reset Value: 00h**

Bit	Bit 7	Bit 6	Bit 5	Bit 4	Bit 3	Bit 2	Bit 1	Bit 0
Status	R	R	R	R	R	R	R	R
Name	IF2_SPI	IF2_MSI <sup>2</sup> C	IF2_ADC	IF2_ACOMP	IF2_LVD	IF2_WTMR	IF2_ETIMER	IF2_IN_TOG

Bit Number	Bit Mnemonic	Description
7	IF2_SPI	1: SPI Interrupt Event Flag be set, SPI Interrupt Flag Clear, refer to section 6.12 XFR[0xC3]
6	IF2_MSI <sup>2</sup> C	1: M/S I <sup>2</sup> C Interrupt Event Flag be set, M/S I <sup>2</sup> C Interrupt Flag Clear, refer to section 6.10 XFR[0xA0]
5	IF2_ADC	1: ADC Interrupt Event Flag be set, will be cleared automatically after ADC conversion
4	IF2_ACOMP	1: ACOMP Interrupt Event Flag be set, ACOMP Interrupt Flag Clear, refer to section 6.14 XFR[0xDB]
3	IF2_LVD	1: LVD Interrupt Event Flag be set, LVD Interrupt Flag Clear, refer to section 6.16 XFR[0x03]
2	IF2_WTMR	1: Watch Timer Interrupt Event Flag be set, Watch Timer Interrupt Flag Clear, refer to section 6.9 XFR[0x7C]
1	IF2_ETIMER	1: Enhanced Timer Interrupt Event Flag be set, Enhanced Timer Interrupt Flag Clear, refer to section 6.11 XFR[0xB2]

Bit Number	Bit Mnemonic	Description
0	IF2_IN_TOG	1: All-Input Toggle Interrupt Event Flag be set, Input Toggle Interrupt Flag Clear, refer to section 6.7 XFR[0x6A]

**8052 External Interrupt 3 (INT3) Flag High Bytes Register IF3\_IRQ[15:8] (XFR: 0x38)    Reset Value: 00h**

Bit	Bit 7	Bit 6	Bit 5	Bit 4	Bit 3	Bit 2	Bit 1	Bit 0
Status	R	R	R	R	R	R	R	R
Name	IF3_IRQ[15:8]							

Bit Number	Bit Mnemonic	Description
7	IF3_IRQ15	1: IRQ15 Interrupt Event Flag be set, IRQ Interrupt Flag Clear, refer to section 6.5 XFR[0x44]
6	IF3_IRQ14	1: IRQ14 Interrupt Event Flag be set, IRQ Interrupt Flag Clear, refer to section 6.5 XFR[0x44]
5	IF3_IRQ13	1: IRQ13 Interrupt Event Flag be set, IRQ Interrupt Flag Clear, refer to section 6.5 XFR[0x44]
4	IF3_IRQ12	1: IRQ12 Interrupt Event Flag be set, IRQ Interrupt Flag Clear, refer to section 6.5 XFR[0x44]
3	IF3_IRQ11	1: IRQ11 Interrupt Event Flag be set, IRQ Interrupt Flag Clear, refer to section 6.5 XFR[0x44]
2	IF3_IRQ10	1: IRQ10 Interrupt Event Flag be set, IRQ Interrupt Flag Clear, refer to section 6.5 XFR[0x44]
1	IF3_IRQ9	1: IRQ9 Interrupt Event Flag be set, IRQ Interrupt Flag Clear, refer to section 6.5 XFR[0x44]
0	IF3_IRQ8	1: IRQ8 Interrupt Event Flag be set, IRQ Interrupt Flag Clear, refer to section 6.5 XFR[0x44]

**8052 External Interrupt 3 (INT3) Flag Low Bytes Register IF3\_IRQ[7:0] (XFR: 0x39)    Reset Value: 00h**

Bit	Bit 7	Bit 6	Bit 5	Bit 4	Bit 3	Bit 2	Bit 1	Bit 0
Status	R	R	R	R	R	R	R	R
Name	IF3_IRQ[7:0]							

Bit Number	Bit Mnemonic	Description
7	IF3_IRQ7	1: IRQ7 Interrupt Event Flag be set, IRQ Interrupt Flag Clear, refer to section 6.5 XFR[0x45]
6	IF3_IRQ6	1: IRQ6 Interrupt Event Flag be set, IRQ Interrupt Flag Clear, refer to section 6.5 XFR[0x45]
5	IF3_IRQ5	1: IRQ5 Interrupt Event Flag be set, IRQ Interrupt Flag Clear, refer to section 6.5 XFR[0x45]
4	IF3_IRQ4	1: IRQ4 Interrupt Event Flag be set, IRQ Interrupt Flag Clear, refer to section 6.5 XFR[0x45]

Bit Number	Bit Mnemonic	Description
3	IF3_IRQ3	1: IRQ3 Interrupt Event Flag be set, IRQ Interrupt Flag Clear, refer to section 6.5 XFR[0x45]
2	IF3_IRQ2	1: IRQ2 Interrupt Event Flag be set, IRQ Interrupt Flag Clear, refer to section 6.5 XFR[0x45]
1	IF3_IRQ1	1: IRQ1 Interrupt Event Flag be set, IRQ Interrupt Flag Clear, refer to section 6.5 XFR[0x45]
0	IF3_IRQ0	1: IRQ0 Interrupt Event Flag be set, IRQ Interrupt Flag Clear, refer to section 6.5 XFR[0x45]

## 6.4 Universal Asynchronous Receiver-Transmitter (UART)

The WT51F104 contains one Universal Asynchronous Receiver-Transmitter (UART0).

As a standard UART of 8052, the Baud rate is selected by the Serial Baud rate Generator in SFR.

On Transmit and Receive, the SFR SBUFx uses two separate registers: a transmit buffer and a receive buffer register.

Transmitting data: Writing to SBUF0 register and loads these data in serial output buffer, and starts transmitting.

Receiving data: Reading SBUF0 register and reading the serial receive buffer. The serial port can transmit and receive simultaneously. It is also one byte receive-buffered, meaning it can commence reception of a second byte before a previously received byte has been read from the receive register to prevent data loss.

### The peripheral registers of UART:

SFR Name	Address	Description
PCON	87H	8052 power control register
SCON0	98H	Serial Port 0, Control Register
SBUF0	99H	Serial Port 0, Data Buffer
SBRG0H	9AH	Serial Baud rate Generator 0, high byte
SBRG0L	9BH	Serial Baud rate Generator 0, low byte

### UART0 Peripheral Registers

#### PCON (Power control register) Address: 87H

7	6	5	4	3	2	1	0
SMOD1	SMOD2	-	-	-	-	-	-

SMOD1: UART0 dual rate bit.

SMOD2: UART1 dual rate bit.

-: unimplemented.

#### SBUF0 (8052 UART0 buffer) Address: 99H

7	6	5	4	3	2	1	0
SBUF0.7	SBUF0.6	SBUF0.5	SBUF0.4	SBUF0.3	SBUF0.2	SBUF0.1	SBUF0.0

The Serial Data Buffer of UART0. It is used to hold the bytes to be received or the bytes to be transmitted from UART0.

#### SBRG0H: Address: 9Ah

7	6	5	4	3	2	1	0
SBRG_EN	BRG_M[10]	BRG_M[9]	BRG_M[8]	BRG_M[7]	BRG_M[6]	BRG_M[5]	BRG_M[4]

Used to configure the Baud rate of UART0 and it must be accessed together with SBRG0L.

**SBRG0L: Address: 9Bh**

7	6	5	4	3	2	1	0
BRG_M[3]	BRG_M[2]	BRG_M[1]	BRG_M[0]	BRG_F[3]	BRG_F[2]	BRG_F[1]	BRG_F[0]

Used to configure the Baud rate of UART0 and it must be accessed together with SBRG0H.

**SCON0 (8052 UART0 control register) Address: 98H**

7	6	5	4	3	2	1	0
SM0_1	SM0_2	SM0_3	REN_0	TB8_0	RB8_0	TI_0	RI_0

Bit Number	Bit Mnemonic	Description
7-6	SM0_1, SM0_2	UART0 mode selection 00: Mode 0 01: Mode 1 10: Mode 2 11: Mode 3
5	SM0_3	Multi-processor Communication Enable bit In Mode 0, if SM0_3 = 0, the multi-processor communication function is disabled. In Mode 1, 2, or 3, if SM0_3 = 1, the multi-processor communication function is enabled.
4	REN_0	UART Receive Enable bit must be cleared by software. REN_0 = 1, receive starts. REN_0 = 0, receive stops.
3	TB8_0	The 9 <sup>th</sup> transmit bit in Mode 2 or Mode 3, can be set or cleared by software.
2	RB8_0	In Mode 0, this bit is invalid. In Mode 1, this bit is Stop bit if SM0_3 = 0 In Mode 2 or 3, the 9 <sup>th</sup> data bit that was received.
1	TI_0	Transmit Interrupt Flag. When an interrupt is complete, this bit will not be restored to "0", and it must be cleared by software. In Mode 0, this bit is set by hardware at the end of the 8 <sup>th</sup> bit, and meantime it can commence a TI_0 interrupt. In Mode 1, 2, or 3, this bit is set by hardware at the end of transmitting Stop bit, and meantime it can commence a TI_0 interrupt.
0	RI_0	Receive Interrupt Flag. When an interrupt is complete, this bit will not be restored to "0", and it must be cleared by software. In Mode 0, this bit is set by hardware at the end of the 8 <sup>th</sup> bit, and meantime it can commence a RI_0 interrupt. In Mode 1, 2, or 3, this bit is set by hardware at the end of transmitting Stop bit, and meantime it can commence a RI_0 interrupt.

The Serial Interface 0 can operate in four modes, as described below.

SM0_1	SM0_2	Mode	Function	Baud Rate
0	0	0	Shift Register	Fosc/12
0	1	1	8-bit UART	Software programmed
1	0	2	8-bit UART	Fosc/32 or Fosc/64
1	1	3	9-bit UART	Software programmed

\*Fosc = MCU clock

### Mode 0

In Mode 0, the Baud rate of Shift transmission register is fixed at 1/12 of the oscillator frequency ( $f_{OSC}/12$ ). At 12 MHz, the Baud rate is 1Mbps. In this mode, no matter on receive or transmit data, Rx0 of CPUs connects each other worked as a serial data bus and Tx0 connects each other worked as a Shift pulse. On Receive, Tx0 pin sent out the shift pulse, and the serial data is received by Rx0 pin; On Transmit, it is also based on the shift pulse sent by Tx0 pin, and sent the serial data by Rx0 pin.

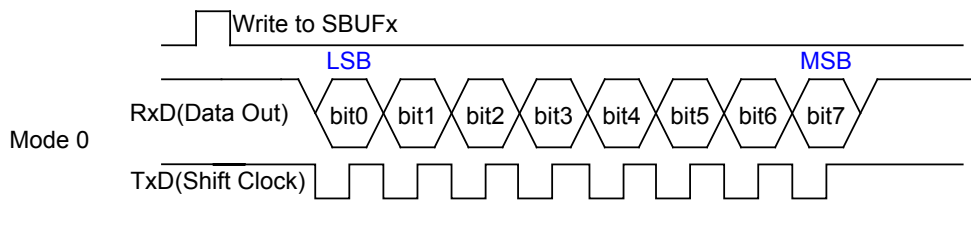

### Mode 1

Mode 1 may have a variable Baud rate for serial data transmit, and the Baud rate is controlled by Timer 1. (If UART1 is supported, Timer 2 is also available for controlling the Baud rate).

In this mode, the Rx0 pin of WT51F104 connects to the destination TxD pin, and the Tx0 pin of WT51F104 connects to the destination RxD pin.

10 bits are length of transmitted or received: a Start bit, 8 data bits, and a Stop bit. The first bit is the low level start bit (0), followed by the 8 data bits (LSB first, starts from bit 0), then the high level stop bit (1) after bit 7 (MSB).





**Mode 2**

Mode 2 operates at  $f_{OSC}/32$  (SMOD = 1) or  $f_{OSC}/64$  (SMOD = 0) for serial data transmission. As for the wire connection, Rx0 pin of WT51F104 connects to destination TxD pin and Tx0 pin of WT51F104 connects to destination RxD pin. 11 bits are length of transmitted or received: a Start bit, 8 data bits, a Parity bit, and 1 Stop bit. The first bit is the low level start bit (0), followed by the 8 data bits (LSB first, starts from bit 0), then the Parity bit after bit 7, and finally the high level stop bit.

On Transmit, TB8\_0 in SCON0 is the 9<sup>th</sup> data bit. The TB8\_0 in SCON0 will transmit the 9<sup>th</sup> data bit; On Receive, the RB8\_0 in SCON0 will receive the 9<sup>th</sup> data bit.

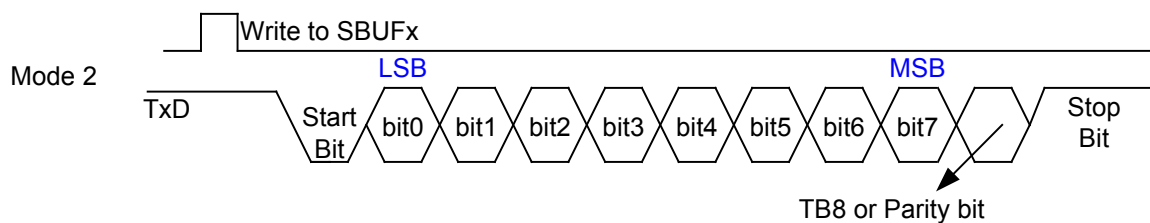

**Mode 3**

The Baud rate in mode 3 is variable for serial data transmission, and it is controlled by Timer 1 (If UART1 is supported, Timer 2 is allowed to control the Baud rate). The operation in Mode 3 is the same as Mode 2.

**Serial Baud rate of UART0:**

SBRG_EN (SBRG0H.7)	SMOD1 (PCON.7)	Baud Rate for UART0
0	0	$\frac{1}{32} \times \frac{f_{osc}}{12 \times (256 - TH1)}$
0	1	$\frac{1}{16} \times \frac{f_{osc}}{12 \times (256 - TH1)}$
1	X	$\frac{f_{osc}}{16 * (BRG\_M[10:0] + \frac{BRG\_F[3:0]}{16})}$

If SBRG\_EN (SBRG0H.7) = 1

UART0 Baud rate = 
$$\frac{f_{osc}}{16 * (BRG\_M[10:0] + \frac{BRG\_F[3:0]}{16})}$$

**Baud rate supporting table:**

Bits/sec	12 MHz				
	Baud Rate Register	BRG_M	BRG_F	Actual	Error
600	1250	1250	0	600	0.0%
1200	625	625	0	1200	0.0%
2400	312.5	312	8	2400	0.0%
4800	156.25	156	4	4800	0.0%
9600	78.125	78	2	9600	0.0%
14400	52.083	52	1	14405	0.04%
19200	39.0625	39	1	19200	0.0%
38400	19.531	19	8	38461	0.16%
57600	13	13	0	57692	0.16%
115200	6.5	6	8	115384	0.16%
230400	3.25	3	4	230769	0.16%

## 6.5 External Interrupt Request (IRQ)

- Supports 16 input Interrupts and built-in digital Filter. (The clock source of digital filter is internal oscillator 12 MHz)
- Supports single-side positive edge-triggered, negative edge-triggered, or positive edge and negative edge triggered simultaneously
- It can work with PWM, applied on motor RPM (Revolutions Per Minute) Control. Please refer to the table below.

**External Interrupt Request (IRQ) & PWM0 mapping table:**

External Interrupt Request (IRQ) pin	PWM0	Output pin
IRQ10	Path A	GPIOB3
IRQ14	Path B	GPIOA4
IRQ0	Path C	GPIOA0
IRQ5	Path D	GPIOB2

**External Interrupt Request (IRQ) & PWM1 mapping table:**

External Interrupt Request (IRQ) pin	PWM1	Output pin
IRQ12	Path A	GPIOB5
IRQ15	Path B	GPIOA5
IRQ2	Path C	GPIOA2
IRQ11	Path D	GPIOB4

**Single side triggered:**

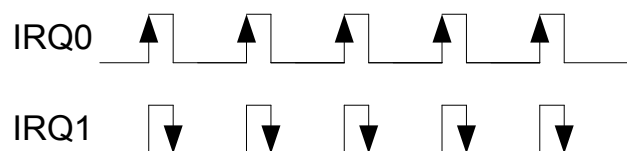

**Bidirectional triggered:**



**External Interrupt Request (IRQ) Control High Bytes Register EN\_IRQ [15:8] (XFR: 0x40) Reset Value: 00h**

Bit	Bit 7	Bit 6	Bit 5	Bit 4	Bit 3	Bit 2	Bit 1	Bit 0
Status	R/W	R/W	R/W	R/W	R/W	R/W	R/W	R/W
Name	EN_IRQ[15:8]							

Bit Number	Bit Mnemonic	Description
7-0	EN_IRQ[15:8]	External Interrupt Request Enable setting. Each bit is corresponded to the related IRQ pin. 1: Enable the External Interrupt Request of the corresponding pins 0: Disable the External Interrupt Request of the corresponding pins

**External Interrupt Request (IRQ) Control Low Bytes Register EN\_IRQ [7:0] (XFR: 0x41) Reset Value: 00h**

Bit	Bit 7	Bit 6	Bit 5	Bit 4	Bit 3	Bit 2	Bit 1	Bit 0
Status	R/W	R/W	R/W	R/W	R/W	R/W	R/W	R/W
Name	EN_IRQ[7:0]							

Bit Number	Bit Mnemonic	Description
7-0	EN_IRQ[7:0]	External Interrupt Request Enable setting. Each bit is corresponded to the related IRQ pin. 1: Enable the External Interrupt Request of the corresponding pins. 0: Disable the External Interrupt Request of the corresponding pins.

**External Interrupt Request (IRQ) Status High Bytes Register EVT\_IRQ [15:8] (XFR: 0x42) Reset Value: 00h**

Bit	Bit 7	Bit 6	Bit 5	Bit 4	Bit 3	Bit 2	Bit 1	Bit 0
Status	R	R	R	R	R	R	R	R
Name	EVT_IRQ[15:8]							

Bit Number	Bit Mnemonic	Description
7-0	EVT_IRQ[15:8]	External Interrupt Request Status. Each bit is corresponded to the related IRQ status. 1: An interrupt trigger occurred in the corresponding pins. 0: An interrupt trigger not occurred in the corresponding pins.

**External Interrupt Request (IRQ) Status Low Bytes Register EVT\_IRQ [7:0] (XFR: 0x43) Reset Value: 00h**

Bit	Bit 7	Bit 6	Bit 5	Bit 4	Bit 3	Bit 2	Bit 1	Bit 0
Status	R	R	R	R	R	R	R	R
Name	EVT_IRQ[7:0]							

Bit Number	Bit Mnemonic	Description
7-0	EVT_IRQ[7:0]	External Interrupt Request Status. Each bit is corresponded to the related IRQ status. 1: An interrupt trigger occurred in the corresponding pins. 0: An interrupt trigger not occurred in the corresponding pins.

**External Interrupt Request (IRQ) Clear High Bytes Register CLR\_IRQ [15:8] (XFR: 0x44) Reset Value: 00h**

Bit	Bit 7	Bit 6	Bit 5	Bit 4	Bit 3	Bit 2	Bit 1	Bit 0
Status	W	W	W	W	W	W	W	W
Name	CLR_IRQ[15:8]							

Bit Number	Bit Mnemonic	Description
7-0	CLR_IRQ[15:8]	External Interrupt Request Clear 1: Writing one to the corresponding bits can clear the interrupt status 0: No action

**External Interrupt Request (IRQ) Clear Low Bytes Register CLR\_IRQ [7:0] (XFR: 0x45) Reset Value: 00h**

Bit	Bit 7	Bit 6	Bit 5	Bit 4	Bit 3	Bit 2	Bit 1	Bit 0
Status	W	W	W	W	W	W	W	W
Name	CLR_IRQ[7:0]							

Bit Number	Bit Mnemonic	Description
7-0	CLR_IRQ[7:0]	External Interrupt Request Clear 1: Writing one to the corresponding bits can clear the interrupt status 0: No action

**External Interrupt Request (IRQ) Bi-directional Trigger High Bytes Register IRQ\_CHG [15:8] (XFR: 0x46) Reset Value: 00h**

Bit	Bit 7	Bit 6	Bit 5	Bit 4	Bit 3	Bit 2	Bit 1	Bit 0
Status	R/W	R/W	R/W	R/W	R/W	R/W	R/W	R/W
Name	IRQ_CHG[15:8]							

Bit Number	Bit Mnemonic	Description
7-0	IRQ_CHG[15:8]	External Interrupt Request Trigger setting 1: Bi-directional triggered 0: Single-side triggered (work together with IRQ_EDGE[15:8] to set positive or negative triggered)

**External Interrupt Request (IRQ) Bi-directional Trigger Low Bytes Register IRQ\_CHG [7:0] (XFR: 0x47) Reset Value: 00h**

Bit	Bit 7	Bit 6	Bit 5	Bit 4	Bit 3	Bit 2	Bit 1	Bit 0
Status	R/W	R/W	R/W	R/W	R/W	R/W	R/W	R/W
Name	IRQ_CHG[7:0]							

Bit Number	Bit Mnemonic	Description
7-0	IRQ_CHG[7:0]	External Interrupt Request Trigger setting 1: Bi-directional triggered 0: Single-side triggered (work together with IRQ_EDGE[7:0] to set positive or negative triggered)

**External Interrupt Request (IRQ) Trigger Edge High Bytes Register IRQ\_EDGE [15:8] (XFR: 0x48) Reset Value: 00h**

Bit	Bit 7	Bit 6	Bit 5	Bit 4	Bit 3	Bit 2	Bit 1	Bit 0
Status	R/W	R/W	R/W	R/W	R/W	R/W	R/W	R/W
Name	IRQ_EDGE[15:8]							

Bit Number	Bit Mnemonic	Description
7-0	IRQ_EDGE[15:8]	External Interrupt Request Trigger Edge setting 1: negative edge triggered 0: positive edge triggered

**External Interrupt Request (IRQ) Trigger Edge Low Bytes Register IRQ\_EDGE [7:0] (XFR: 0x49) Reset Value: 00h**

Bit	Bit 7	Bit 6	Bit 5	Bit 4	Bit 3	Bit 2	Bit 1	Bit 0
Status	R/W	R/W	R/W	R/W	R/W	R/W	R/W	R/W
Name	IRQ_EDGE[7:0]							

Bit Number	Bit Mnemonic	Description
7-0	IRQ_EDGE[7:0]	External Interrupt Request Trigger Edge setting 1: negative edge trigger 0: positive edge trigger

## 6.6 Pulse Width Modulation (PWM)

WT51F104 provides two 16-bit precise Pulse Width Modulation modules to generate periods and Duty cycles.

- Output Frequency is 65535 levels; frequency range: 6 MHz ~ 183.1 Hz (at IRC 12 MHz)
- The resolutions of Duty and period and source clock are closely related to each other.

$$\boxed{\text{Source clock}} = \boxed{\text{Duty resolution}} \times \boxed{\text{Period}}$$

- For example, if Source clock is IRC 12 MHz, Duty Resolution is 10 bit, and then the period range is limited within 11.7 kHz.
- Output type: push pull or open drain, can be configured by GPIOx\_TYP[x] (GPIOF0, GPIOA7) register
- Pulse Width output will trigger external interrupt request (IRQ) to generate an interrupt, and which is used to calculate the numbers of PWM output or generate Period INT/Duty INT for Motor control application
- PWM0 & PWM1 can select different output pins by the Complex Function Setting Register for more applications

PWM0 can select four pins by General-purpose I/O port x Complex Function Setting Register, and one pin is for output.

PWM0	Output pin	External Interrupt Request (IRQ) pin	General-purpose I/O Port x Complex Function Setting Register
Path A	GPIOB3	IRQ10	GPB3_FUN_SLT[2:0] = 011
Path B	GPIOA4	IRQ14	GPA4_FUN_SLT[1:0] = 011
Path C	GPIOA0	IRQ0	GPA0_FUN_SLT[1:0] = 010
Path D	GPIOB2	IRQ5	GPB2_FUN_SLT[1:0] = 011

PWM1 can select four pins by General-purpose I/O port x Complex Function Setting Register, and one pin is for output.

PWM1	Output pin	External Interrupt Request (IRQ) pin	General-purpose I/O Port x Complex Function Setting Register
Path A	GPIOB5	IRQ12	GPB5_FUN_SLT[2:0] = 011
Path B	GPIOA5	IRQ15	GPA5_FUN_SLT[2:0] = 011
Path C	GPIOA2	IRQ2	GPA2_FUN_SLT[1:0] = 011
Path D	GPIOB4	IRQ11	GPB4_FUN_SLT[2:0] = 011

For example, PWM0 outputs 5 pulses can be done by the positive-edge triggered of IRQ10, after counting for 5 times, turning off PWM. Moreover, the period of PWM is able to calculate.

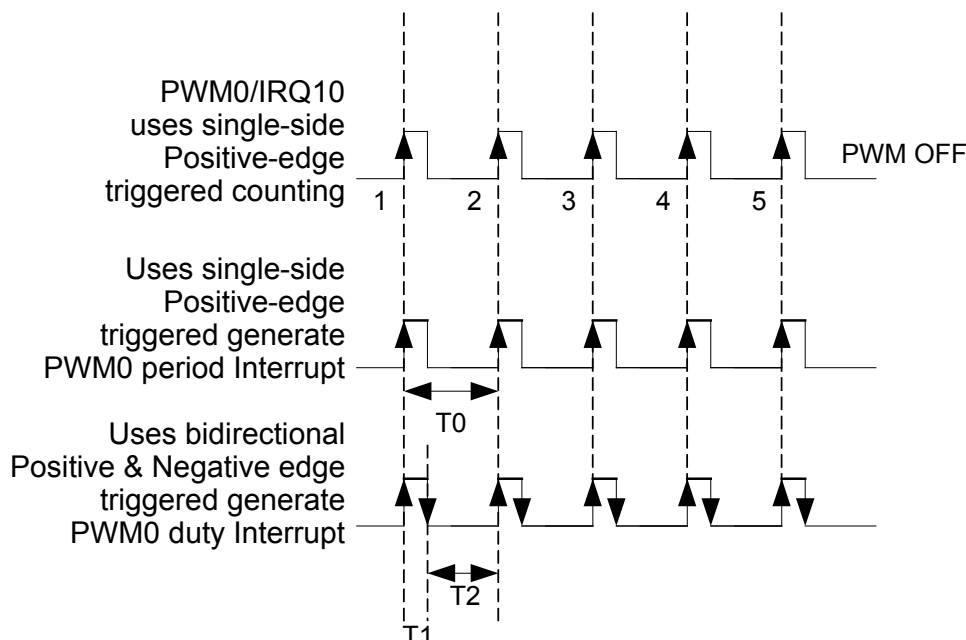

**PWM Control Register PWM\_CTL (XFR: 0x50)**

**Reset Value: 00h**

Bit	Bit 7	Bit 6	Bit 5	Bit 4	Bit 3	Bit 2	Bit 1	Bit 0
Status	-	-	R/W	R/W	-	R/W	R/W	R/W
Name	Reserved		PWM_PLRTY[1:0]		Reserved	LBYTE_UPD_EN	PWM_EN[1:0]	

Bit Number	Bit Mnemonic	Description
7-6	Reserved	-
5-4	PWM_PLRTY[1:0]	Bit 5: 1: PWM1 negative edge output 0: PWM1 positive edge output Bit 4: 1: PWM0 negative edge output 0: PWM0 positive edge output
3	Reserved	-
2	LBYTE_UPD_EN	1: Enable updating PWM output while writing PWM period or Duty Cycle Control Low Bytes Register 0: Disable updating PWM output while writing PWM period or Duty Cycle Control Low Bytes Register
1	PWM_EN[1:0]	1: Enable PWM1 function 0: Disable PWM1 function
0		1: Enable PWM0 function 0: Disable PWM0 function

**-: unimplemented.**



**PWM0 Period Control High Bytes Register PWM0\_PRD[15:8] (XFR: 0x51)**
**Reset Value: 00h**

Bit	Bit 7	Bit 6	Bit 5	Bit 4	Bit 3	Bit 2	Bit 1	Bit 0
Status	R/W	R/W	R/W	R/W	R/W	R/W	R/W	R/W
Name	PWM0_PRD[15:8]							

Bit Number	Bit Mnemonic	Description
7-0	PWM0_PRD[15:8]	PWM0_PRD[15:8] sets the output period of PWM0, and which is paired with PWM0_PRD[7:0] to form a 16-bit of period control value. PWM0 period: SOURCE clock/ (PWM0_PRD[15:0]+1), source clock: 12 MHz IRC, DC ~ 24 MHz Crystal OSC. 32 kHz IRC and 32.768 kHz Crystal OSC.

**PWM0 Period Control Low Bytes Register PWM0\_PRD[7:0] (XFR: 0x52)**
**Reset Value: 01h**

Bit	Bit 7	Bit 6	Bit 5	Bit 4	Bit 3	Bit 2	Bit 1	Bit 0
Status	R/W	R/W	R/W	R/W	R/W	R/W	R/W	R/W
Name	PWM0_PRD[7:0]							

Bit Number	Bit Mnemonic	Description
7-0	PWM0_PRD[7:0]	PWM0_PRD[7:0] sets the output period of PWM0, and which is paired with PWM0_PRD[15:8] to form a 16-bit of period control value. PWM0 period: SOURCE clock/ (PWM0_PRD[15:0]+1), source clock: 12 MHz IRC, DC ~ 24 MHz Crystal OSC. 32 kHz IRC and 32.768 kHz Crystal OSC.

**PWM0 Duty Cycle Control High Bytes Register PWM0\_DUTY[15:8] (XFR: 0x53)**
**Reset Value: 00h**

Bit	Bit 7	Bit 6	Bit 5	Bit 4	Bit 3	Bit 2	Bit 1	Bit 0
Status	R/W	R/W	R/W	R/W	R/W	R/W	R/W	R/W
Name	PWM0_DUTY[15:8]							

Bit Number	Bit Mnemonic	Description
7-0	PWM0_DUTY[15:8]	Sets the duty cycle output of PWM0. PWM0_DUTY[15:8] sets the duty cycle of PWM0, and is paired with PWM0_DUTY[7:0] to form a 16-bit of duty cycle control value.

**Note: The maximum setting of Duty must be a reasonable value.**
**PWM0 Duty Cycle Control Low Bytes Register PWM0\_DUTY[7:0] (XFR: 0x54)**
**Reset Value: 00h**

Bit	Bit 7	Bit 6	Bit 5	Bit 4	Bit 3	Bit 2	Bit 1	Bit 0
Status	R/W	R/W	R/W	R/W	R/W	R/W	R/W	R/W
Name	PWM0_DUTY[7:0]							

Bit Number	Bit Mnemonic	Description
7-0	PWM0_DUTY[7:0]	Set the duty cycle output of PWM0 PWM0_DUTY[7:0] sets the duty cycle of PWM0, and is paired with PWM0_DUTY[15:8] to form a 16-bit of duty cycle control value.

**Note: The maximum setting of Duty must be a reasonable value.**

**PWM1 Period Control High Bytes Register PWM1\_PRD[15:8] (XFR: 0x55)**
**Reset Value: 00h**

Bit	Bit 7	Bit 6	Bit 5	Bit 4	Bit 3	Bit 2	Bit 1	Bit 0
Status	R/W	R/W	R/W	R/W	R/W	R/W	R/W	R/W
Name	PWM1_PRD[15:8]							

Bit Number	Bit Mnemonic	Description
7-0	PWM1_PRD[15:8]	PWM1_PRD[15:0] sets the output period of PWM1, and is paired with PWM1_PRD[7:0] to form a 16-bit of duty cycle control value. PWM1 period: SOURCE clock/ (PWM1_PRD[15:0]+1), source clock: 12 MHz IRC, DC ~ 24 MHz Crystal OSC. 32 kHz IRC and 32.768 kHz Crystal OSC.

**PWM1 Period Control Low Bytes Register PWM1\_PRD[7:0] (XFR: 0x56)**
**Reset Value: 01h**

Bit	Bit 7	Bit 6	Bit 5	Bit 4	Bit 3	Bit 2	Bit 1	Bit 0
Status	R/W	R/W	R/W	R/W	R/W	R/W	R/W	R/W
Name	PWM1_PRD[7:0]							

Bit Number	Bit Mnemonic	Description
7-0	PWM1_PRD[7:0]	PWM1_PRD[7:0] sets the output period of PWM1, and is paired with PWM1_PRD[15:8] to form a 16-bit of duty cycle control value. PWM1 period: SOURCE clock/ (PWM1_PRD[15:0]+1), source clock: 12 MHz IRC, DC ~ 24 MHz Crystal OSC. 32 kHz IRC and 32.768 kHz Crystal OSC.

**PWM1 Duty Cycle Control High Bytes PWM1\_DUTY[15:8] (XFR: 0x57)**
**Reset Value: 00h**

Bit	Bit 7	Bit 6	Bit 5	Bit 4	Bit 3	Bit 2	Bit 1	Bit 0
Status	R/W	R/W	R/W	R/W	R/W	R/W	R/W	R/W
Name	PWM1_DUTY[15:8]							

Bit Number	Bit Mnemonic	Description
7-0	PWM1_DUTY[15:8]	Sets the duty cycle output of PWM1 PWM1_DUTY[15:8] sets the duty cycle of <b>PWM1</b> , and is paired with PWM1_DUTY[7:0] to form a 16-bit of duty cycle control value.

**Note: The maximum setting of Duty must be a reasonable value.**

**PWM1 Duty Cycle Control Low Bytes Register PWM1\_DUTY[7:0] (XFR: 0x58)**
**Reset Value: 00h**

Bit	Bit 7	Bit 6	Bit 5	Bit 4	Bit 3	Bit 2	Bit 1	Bit 0
Status	R/W	R/W	R/W	R/W	R/W	R/W	R/W	R/W
Name	PWM1_DUTY[7:0]							

Bit Number	Bit Mnemonic	Description
7-0	PWM1_DUTY[7:0]	Sets the duty cycle of PWM1 PWM1_DUTY[7:0] sets the duty cycle of <b>PWM1</b> , and is paired with PWM1_DUTY[15:8] to form a 16-bit duty cycle control value.

**Note: The maximum setting of Duty must be a reasonable value.**

**PWM0/PWM1 Period Setting example:**

$$\text{Period} = \frac{\text{Source clock (if: IRC 12MHz)}}{\text{PWMx\_PRD} + 1}$$

PWMx_PRD	PWM output period
1	6 MHz (Max.)
3	3 MHz
11	1 MHz
23	500 kHz
59	200 kHz
119	100 kHz
239	50 kHz
599	20 kHz
1199	10 kHz
2399	5 kHz
2999	4 kHz
3999	3 kHz
5999	2 kHz
11999	1 kHz
23999	500 Hz
29999	400 Hz
39999	300 Hz
59999	200 Hz
65535	183.1 Hz (Min.)

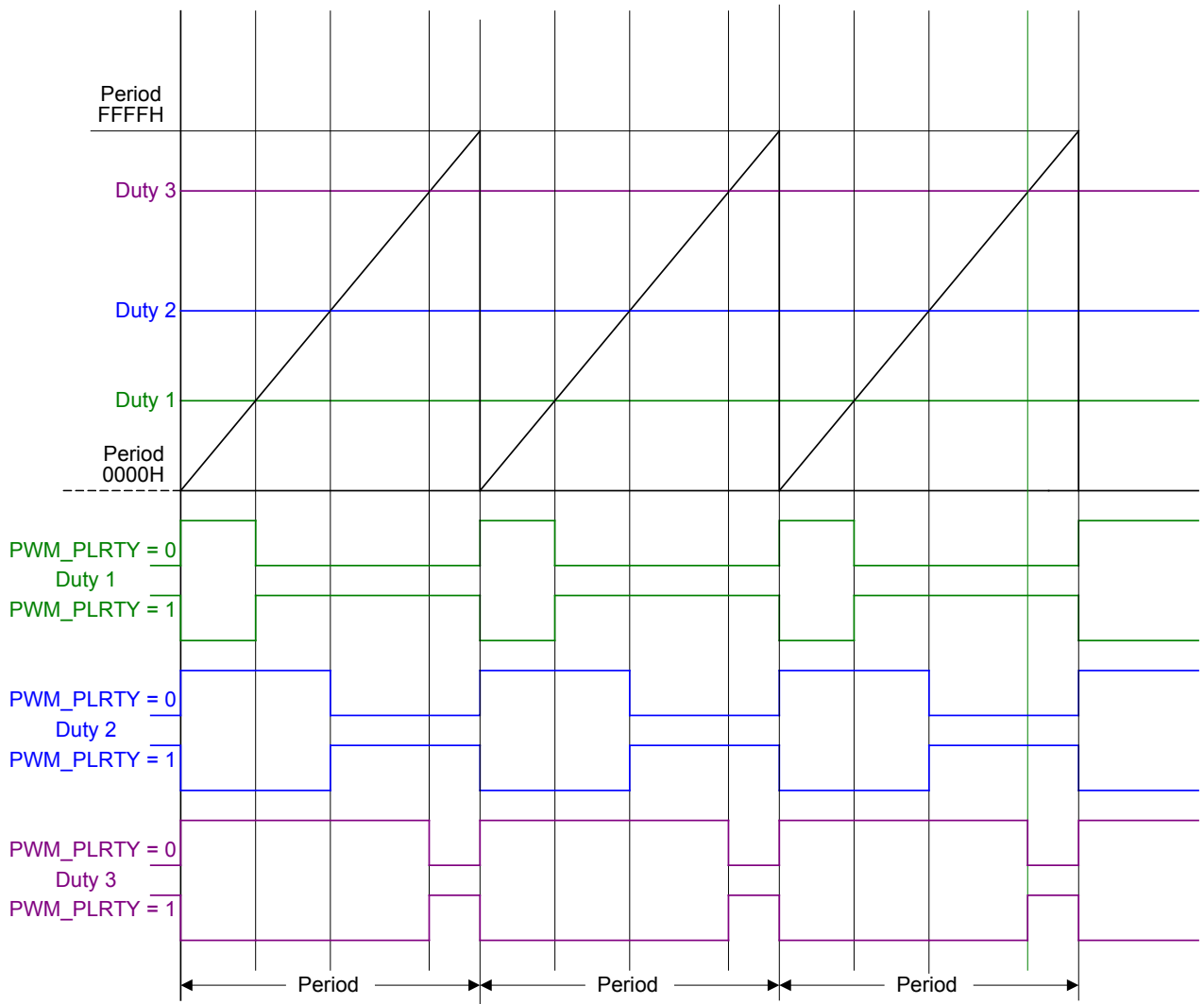

## 6.7 Power Management

WT51F104 provides 4 operation modes, as listed below.

- Normal mode
- Green mode
- Idle mode
- Sleep mode

Four operation mode switching is illustrated in the figure below:

Operating Mode	8052	Peripheral Clock	XTAL (12 MHz)	XTAL (32.768 kHz)	IRC (12 MHz)	IRC (32 kHz)	Power Consumption@5V	Note
Normal 1	on	on	off	off	on	on	3mA	*1
Normal 2	on	on	off	on	on	on	3mA	*2
Normal 3	on	on	on	off	off	off	3.5mA	*3
Green 1	on	on	off	off	off	on	17uA	*4 *6
Green 2	on	on	off	on	off	on	200uA	*5 *6
Idle 1	off	on	off	off	on	on	650uA	*7 *9 *12
Idle 2	off	off	off	off	on	on	500uA	*8 *9 *12
Sleep 1	off	off	off	off	off	off	300uA	*10 *12
Sleep 2	off	off	off	off	off	off	5uA	*11 *12

### Notes:

1. LVD&LVDR power consumption is about 5uA@5V

2. LVR power consumption is about 5uA@5V

3. BLDO power consumption 160uA@5V (can be turned off only on Green 1 mode)

\*1 Normal 1 Mode: MCU all use the internal oscillator, and therefore this mode is the most cost-saving mode, but IRC 12 MHz will be affected by the impact of temperature, please refer to section 7.5.

\*2 Normal 2 Mode: use external oscillator 32.768 kHz to calibrate IRC 12 MHz, and calibration can reach  $\pm 1\%$ .

\*3 Normal 3 Mode: this mode is focused on precise high frequency. Calendar or Clock function can only be achieved by 8052 Timer due to without external 32.768 kHz oscillator.

\*4 Green 1 Mode: After Source clock selecting internal IRC 32 kHz, manually turn off main BLDO to reduce power consumption. The frequency tolerance of internal IRC 32 kHz is  $\pm 30\%$ .

**\*5 Green 2 Mode:** Source clock also selects internal IRC 32 kHz and it requires manually turning on the power of external crystal oscillator 32.768 kHz (CRY\_32K\_PD) manually. Due to main BLDO controls the power of the external oscillator, main BLDO cannot be turned off. In addition, the system reference source of the Watch Timer selects external crystal oscillator 32.768 kHz, and have the External Clock Source Prescaler (EN\_CRY\_DIV = 1 & CRY\_DIV[9:0]=1) setting divided by 2. In the meantime, the time period selected by the Watch Timer will be extended twice. In this mode, the system clock source is Internal IRC 32 kHz. While the Watch Timer system source clock is external Crystal Oscillator 32.768 kHz divided by 2 is 16.384 kHz, and then the precise Calendar or Clock function can be achieved.

MCU Source Clock	Watch Timer Clock	Power Consumption	Note
IRC 32 kHz	IRC 32 kHz	< 20uA@5V	
IRC 32 kHz	Ext 32.768 kHz	< 220uA@5V	IRC 32 kHz $\pm$ 30% This mode cannot capture the Interrupt Event of Watch Timer due to System clock < Watch Timer Clock. EN_CRY_DIV = 1 & CRY_DIV[9:0] = 1
IRC 32 kHz	Ext 32.768 kHz / 2 = 16.384 kHz		
Ext 32.768 kHz	Ext 32.768 kHz	> 400uA@5V	

**\*6 Prior to switching back to Normal x Mode in Green 1 mode,** please turn on main BLDO first, then select Source clock to work at internal IRC 12 MHz or external 12 MHz.

**\*7 Idle 1 Mode:** Enable MCU\_CLK\_OFF to enter Idle mode, this mode wakeup fast and support the most wakeup sources, please refer to the Wakeup source illustration figure as below.

**\*8 Idle 2 Mode:** Enable SYSTEM\_CLK\_OFF to enter Idle mode, this mode turn off Peripheral Clock, thus MCU cannot use INT0/1/2\_WK to wakeup, please refer to the Wakeup source illustration figure as below.

**\*9 Wakeup time of Idle 1 & Idle 2 Mode:** Source clock 12 MHz wakeup time  $2 * (1/12 \text{ MHz}) = 166\text{ns}$  ; Source clock 32 kHz Wakeup time  $2 * (1/32 \text{ kHz}) = 62.5\text{us}$

**\*10 Sleep 1 Mode.:** This mode is about Source clock enable IRC12M\_CLK\_OFF at IRC 12 MHz, allowing MCU to enter Sleep mode, and support fast Wakeup. The wakeup time is  $8 * (1 / 12 \text{ MHz}) = 666\text{ns}$ . Please refer to the Wakeup source illustration figure as below.

**\*11 Sleep 2 Mode.:** Enable SOURCE\_CLK\_OFF to enter Sleep mode, Wakeup time: if Source clock is IRC 12 MHz,  $128 * (1 / 12 \text{ MHz}) = 10.66\text{us}$ ; if Source clock is external crystal oscillator 12 MHz,  $16*1024 * (1 / 12 \text{ MHz}) = 1360\text{us}$ . Please refer to the Wakeup source illustration figure as below.

**\*12 Adopts Watch Timer Wakeup in Idle & Sleep mode,** turn on the External Sub crystal oscillator power (IRC\_32K\_PD or CRY\_32K\_PD) as the clock source of Watch Timer, in the meantime the power-consuming is increasing.

MCU Operation Mode figure:

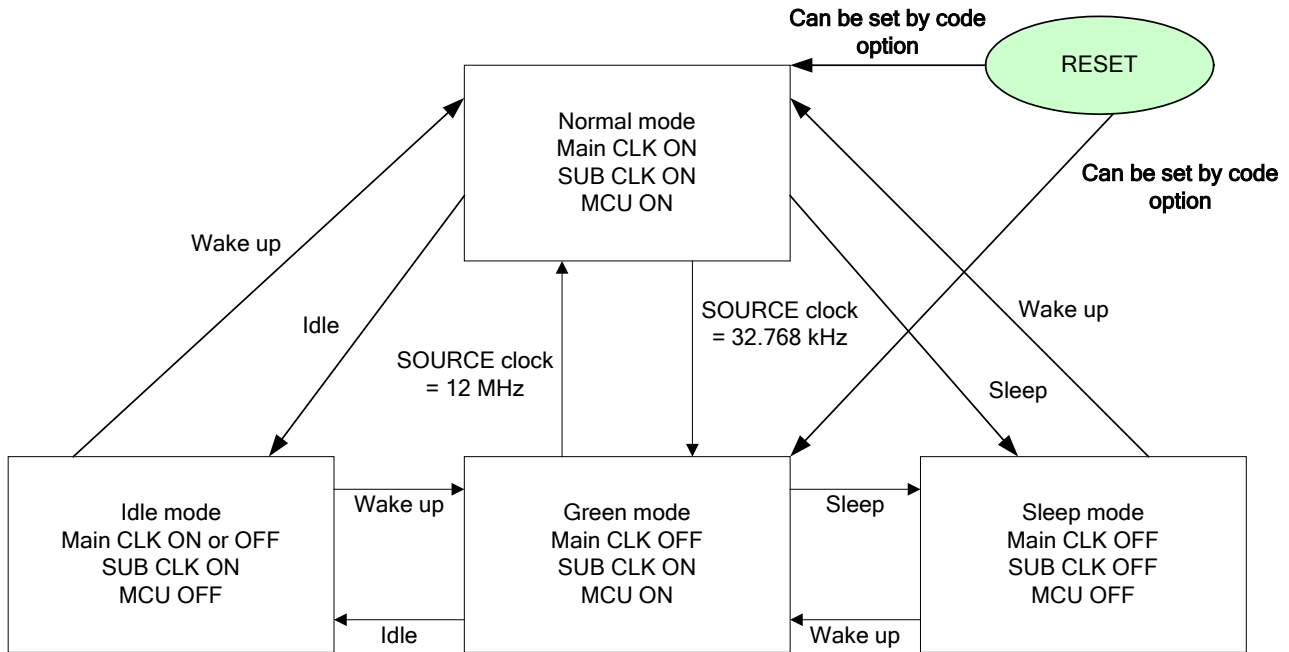

WT51F104 provides many sources of wakeup returning itself from sleep/idle mode to normal mode.

The figure below illustrated the Wakeup sources below each mode:

SOURCE		Idle 1	Idle 2	Sleep Mode
		MCU_CLK_OFF	SYSTEM_CLK_OFF	SOURCE_CLK_OFF IRC12M_CLK_OFF
NRST		○	○	○
GPIOx_WK[x]		○	○	○
INT0/1/2_WK	IE0/1/2_SPI	○	×	×
	IE0/1/2_MSIC	○	×	×
	IE0/1/2_ADC	×	×	×
	IE0/1/2_ACOMP	○	×	×
	IE0/1/2_LVD	○	○	○
	IE0/1/2_WTMR	×	×	×
	IE0/1/2_ETIMER	○	×	×
	IE0/1/2_IN_TOG	○	○	○
INT3_WK	IRQ[15:0]	×	×	×
ADC_WK		○	○	○
ACOMP_WK		○	○	○
WTMR_WK		○	○	○

**Notes:**

1. GPIOx\_WK[x] & IE0/1/2\_IN\_TOG: only support 18 general-purpose I/O pin Toggle (GPIO A/B/C).
2. IRQ[15:0]: IRQ did not support wakeup, please use GPIOx\_WK[x] to wakeup.
3. ADC\_WK: Based on input source for comparing Toggle wakeup
4. WTMR\_WK: Turn on sub crystal oscillator (IRC 32 kHz or Ext 32 kHz) and sub crystal oscillator power to be the clock source of Watch Timer.



**ISP Clock Source Control Register ISP\_CHG\_CTL (XFR: 0x04)**
**Reset Value: 00h**

Bit	Bit 7	Bit 6	Bit 5	Bit 4	Bit 3	Bit 2	Bit 1	Bit 0
Status	R/W	-	R/W	R	-	-	R	R
Name	ISP_CHG_12M	Reserved	UART_ISP_CHG	ISP_CHG_FLAG	Reserved	LVD_RST_ACT_FLG	LVR_ACT_FLG	

Bit Number	Bit Mnemonic	Description
7	ISP_CHG_12M	When MCU is in Green & Sleep mode, ISP pin will turn on the internal 12 MHz RC oscillator automatically 1: Enable 0: Disable
6	Reserved	-
5	UART_ISP_CHG	UART pin (GPIA3) trigger ISP clock source as internal 12 MHz RC oscillator 1: Enable 0: Disable
4	ISP_CHG_FLAG	ISP_CHG_FLAG = 1: MCU is waking up by SWUT pin. Turn on internal 12 MHz RC oscillator and switch SOURCE clock to 12 MHz. Clear ISP_CHG_FLAG by setting ISP_CHG_12M bit = 0.
3-2	Reserved	-
1	LVD_RST_ACT_FLG	1: Power Voltage < Setting Low Voltage Detection Reset Range. (This flag is not connected to the Analog Filter, and will be affected easily. For reference only.)
0	LVR_ACT_FLG	1: Power Voltage < Internal Low Voltage Reset Range. (This flag is not connected to the Analog Filter, and will be affected easily. For reference only.)

-: unimplemented.

**Note: If Source clock is in non 12 MHz application, please add below Forcing Toggle SWUT setting procedure to the pro gram enabling MCU programming repeatedly.**

**Non-12 MHz mode contains: Green, Sleep mode for use external oscillator (non 12 MHz) can enable ISP\_CHG\_12M & UART\_ISP\_CHG bit allow MCU pin trigger to switch the SOURCE clock & ISP clock to internal 12 MHz RC oscillator by SWUT, and meanwhile MCU can receive the correct ISP command.**

Mandatory trigger SWUT setting procedures:

1. Program Initialized Enable ISP\_CHG\_12M & UART\_ISP\_CHG bit  
rISP\_CHG\_CTL = 0xA0;
2. Program main loop judge if ISP\_CHG\_FLAG been triggered, and based on Sleep mode to add one software mechanism, please refer to the example program.  
void DRV\_CheckSwutTriggerWakeup(void)  
{  
    //If enable rISP\_CHG\_CTL of bit 7 and Bit.  
    //When Swut pin have hi to low(2V) level, Mcu will change source clock to IRC 12 MHz  
    if(rISP\_CHG\_CTL & 0x10)  
    {  
        DRV\_SoftwareWakeup();  
    }

```

//need delay 100ms(minimum) to wait ISP command, Don't remove this delay command
DelayWhile(100);           //This time MCU change source clock to IRC 12 MHz

rISP_CHG_CTL = 0x00;      //Disable ISP change clock. MCU go back to original setting
rISP_CHG_CTL = 0xA0;      //Enable ISP change clock
    }
}

```

**System Clock Source Control Register SOURCE\_CLK\_SLT (XFR: 0x05) Reset Value: A0h**

Bit	Bit 7	Bit 6	Bit 5	Bit 4	Bit 3	Bit 2	Bit 1	Bit 0
Status	-	-	-	-	R/W	R/W	R/W	R/W
Name	Reserved				SOURCE_CLK_SLT[1:0]		MCU_CLK_SLT[1:0]	

Bit Number	Bit Mnemonic	Description
7-4	Reserved	Must be equal to "1010", otherwise bit [3:0] cannot be written into.
3-2	SOURCE_CLK_SLT[1:0]	Select SOURCE clock sources 00: Internal 12 MHz RC oscillator (default) 01: External DC ~ 24 MHz crystal oscillator 10: Internal 32 kHz RC oscillator Default value can be selected by section 6.18 Code Option Select
1-0	MCU_CLK_SLT[1:0]	MCU clock setting 00: MCU clock = SOURCE clock (default) 01: MCU clock = SOURCE clock /2 10: MCU clock = SOURCE clock /4 11: MCU clock = SOURCE clock /12

**-: unimplemented.**

**Notes:**

- Due to external crystal oscillator pin supports both 12 MHz & 32.768 kHz crystal oscillator, do not turn off BLDO\_PD when SOURCE clock selects external 32.768 kHz crystal oscillator. Otherwise, SOURCE clock will stop working and fail to programming. Please select SOURCE clock as internal 32 kHz RC oscillator to work together with WatchTimer selecting external 32.768 kHz crystal oscillator.
- When SOURCE clock selects internal 32 kHz RC oscillator and the system clock source of the Watch Timer selects External 32.768 kHz crystal oscillator, Interrupt sources cannot be captured in time due to Internal 32 kHz RC oscillator with huge tolerance and the execute speed is slower than the Interrupt generated by Watch Timer. In this mode, it requires having the External Clock Source Prescaler Control Register 1 and External Clock Source Prescaler Control Register 2 setting divided by 2, and the Watch Timer clock source divided by 2 equals to 16.384 kHz. In the meantime, the time period selected by the Watch Timer will be extended twice to capture completely without missing.

**Setting External Clock Source/ 2 procedures:**

- Setting Prescaler Data: CRY\_DIV[9:0] = 1, and  $32.768 \text{ kHz} / (\text{CRY\_DIV}[9:0] + 1) = 32.768 \text{ kHz} / 2 = 16.384 \text{ kHz}$
- Enable external crystal oscillator clock source prescaler: EN\_CRY\_DIV = 1

**Power-saving Control Register POWER\_SAVE\_CTL (XFR: 0x06)**
**Reset Value: 50h**

Bit	Bit 7	Bit 6	Bit 5	Bit 4	Bit 3	Bit 2	Bit 1	Bit 0
Status	-	-	-	-	R/W	R/W	R/W	R/W
Name	Reserved			MCU_CLK_OFF	SYSTEM_CLK_OFF	SOURCE_CLK_OFF	IRC12M_CLK_OFF	

Bit Number	Bit Mnemonic	Description
7-4	-	Must be equal to "0101", otherwise, Bit[3:0] cannot be written into
3	MCU_CLK_OFF	1: MCU clock is Off (including MCU and partial peripheral hardware), and MCU must wait for two MCU clock cycles until MCU clock ON and work. 0: MCU clock is On.
2	SYSTEM_CLK_OFF	1: System clock is Off (including MCU and partial peripheral hardware), and MCU must wait for two MCU clock cycles until system clock ON and work. 0: MCU clock is On.
1	SOURCE_CLK_OFF (bias OFF)	1: SOURCE clock is Off. SOURCE clock sources: (MCU clock is closed and bias OFF) External 24 MHz or 32.768 kHz crystal oscillator, and MCU must wait for 1024 SYSTEM clock cycles until source clock ON and work. Internal 24 MHz or 32 kHz RC oscillator, and MCU must wait for 128 SYSTEM clock cycles until source clock ON and work. 0: MCU clock is On.
0	IRC12M_CLK_OFF (bias ON)	1: Internal 12 MHz RC oscillator is Off and bias ON MCU must wait for eight IRC 12M clock cycles until IRC12M ON and work. 0: MCU clock is On.

-: unimplemented.

**Note:** Refer to section 3.1 System Clock Tree for more details.

**Clock Source Control Register IRC\_12M\_PD (XFR: 0x07)**
**Reset Value: A2h**

Bit	Bit 7	Bit 6	Bit 5	Bit 4	Bit 3	Bit 2	Bit 1	Bit 0
Status	-	-	-	R/W	R/W	R/W	R/W	-
Name	Reserved			IRC_12M_PD1	IRC_12M_PD2	IRC_32K_PD	CRY_12M_PD	Reserved

Bit Number	Bit Mnemonic	Description
7-5	-	Must be equal to "101", otherwise bit[4:0] cannot be written into
4	IRC_12M_PD1	1: Partial internal 12 MHz RC oscillator power is turned off (bias ON) (default value is not off) 0: Not off
3	IRC_12M_PD2	1: All internal 12 MHz RC oscillator power are closed (bias off) (default value is not off) 0: Not off

Bit Number	Bit Mnemonic	Description
2	IRC_32K_PD	1: Internal 32 kHz RC oscillator power is turned off (default value is not off) 0: Not off
1	CRY_12M_PD	1: External 12 MHz crystal oscillator power is turned off (default value is off) 0: Not off
0	Reserved	-

-: unimplemented.

**Oscillator Driver Control Register CRY\_12M\_DR[1:0] (XFR: 0x08)**
**Reset Value: 54h**

Bit	Bit 7	Bit 6	Bit 5	Bit 4	Bit 3	Bit 2	Bit 1	Bit 0
Status	-	-	-	-	-	R/W	R/W	R/W
Name	Reserved				Reserved	CRY_12M_DR[1:0]	BLDO_PD	

Bit Number	Bit Mnemonic	Description
7-4	Reserved	Must be equal to "0101", otherwise, Bit[3:0] cannot be written into
3	Reserved	-
2-1	CRY_12M_DR[1:0]	External oscillator driving ability setting 00: Crystal oscillator with frequency < 100 kHz 01: Crystal oscillator with frequency of 100 kHz ~ 1 MHz 10: Crystal oscillator with frequency of 1 MHz ~ 12 MHz (default) 11: Crystal oscillator with frequency of 12 MHz ~ 24 MHz Default value can be selected by section 6.18 Code Option Select
0	BLDO_PD	Internal voltage regulator (main LDO) 1: Turn off main LDO 0: Turn on main LDO (default) Default value can be selected by section 6.18 Code Option Select

-: unimplemented.

**Note:** Main LDO is turned off only on Green mode, if SOURCE clock is 12 MHz (IRC Internal or External crystal oscillator) main LDO must be turned on, otherwise system may work abnormally and leads to programming failure.

**Note:** Due to WT51F104 only supports one set of external oscillator input, it requires setting the driving ability of oscillator according to the frequency of external oscillator input.

Please see the table below.

External Crystal Oscillator	CRY_12M_DR[1:0]
24 MHz	11
12 MHz	10
32.768 kHz	00

**General-purpose I/O Port A Wakeup Control Register GPIOA\_WK[5:0] (XFR: 0x60)      Reset Value: 00h**

Bit	Bit 7	Bit 6	Bit 5	Bit 4	Bit 3	Bit 2	Bit 1	Bit 0
Status	-	-	R/W	R/W	R/W	R/W	R/W	R/W
Name	Reserved		GPIOA_WK[5:0]					

Bit Number	Bit Mnemonic	Description
7-6	Reserved	-
5-0	GPIOA_WK[5:0]	General-purpose I/O Port A Wakeup MCU Enable setting Bit 5 = 1: Enable General-purpose I/O Port A5 Wakeup MCU function; 0: Function disabled Bit 4 = 1: Enable General-purpose I/O Port A4 Wakeup MCU function; 0: Function disabled Bit 3 = 1: Enable General-purpose I/O Port A3 Wakeup MCU function; 0: Function disabled Bit 2 = 1: Enable General-purpose I/O Port A2 Wakeup MCU function; 0: Function disabled Bit 1 = 1: Enable General-purpose I/O Port A1 Wakeup MCU function; 0: Function disabled Bit 0 = 1: Enable General-purpose I/O Port A0 Wakeup MCU function; 0: Function disabled

∴ unimplemented.

**General-purpose I/O Port B Wakeup Control Register GPIOB\_WK[5:0] (XFR: 0x61)      Reset Value: 00h**

Bit	Bit 7	Bit 6	Bit 5	Bit 4	Bit 3	Bit 2	Bit 1	Bit 0
Status	-	-	R/W	R/W	R/W	R/W	R/W	R/W
Name	Reserved		GPIOB_WK[5:0]					

Bit Number	Bit Mnemonic	Description
7-6	Reserved	-
5-0	GPIOB_WK[5:0]	General-purpose I/O Port B Trigger Wakeup MCU Enable setting Bit 5 = 1: Enable General-purpose I/O Port B5 Trigger Wakeup MCU function; 0: Function disabled Bit 4 = 1: Enable General-purpose I/O Port B4 Trigger Wakeup MCU function; 0: Function disabled Bit 3 = 1: Enable General-purpose I/O Port B3 Trigger Wakeup MCU function; 0: Function disabled Bit 2 = 1: Enable General-purpose I/O Port B2 Trigger Wakeup MCU function; 0: Function disabled Bit 1 = 1: Enable General-purpose I/O Port B1 Trigger Wakeup MCU function; 0: Function disabled

Bit Number	Bit Mnemonic	Description
		Bit 0 = 1: Enable General-purpose I/O Port B0 Trigger Wakeup MCU function; 0: Function disabled

∴ unimplemented.

**General-purpose I/O Port C Wakeup Control Register GPIOC\_WK[5:0] (XFR: 0x62)      Reset Value: 00h**

Bit	Bit 7	Bit 6	Bit 5	Bit 4	Bit 3	Bit 2	Bit 1	Bit 0
Status	-	-	R/W	R/W	R/W	R/W	R/W	R/W
Name	Reserved		GPIOC_WK[5:0]					

Bit Number	Bit Mnemonic	Description
7-6	Reserved	-
5-0	GPIOC_WK[5:0]	General-purpose I/O Port C Trigger Wakeup MCU Enable setting Bit 5 = 1: Enable General-purpose I/O Port C5 Trigger Wakeup MCU function; 0: Function disabled Bit 4 = 1: Enable General-purpose I/O Port C4 Trigger Wakeup MCU function; 0: Function disabled Bit 3 = 1: Enable General-purpose I/O Port C3 Trigger Wakeup MCU function; 0: Function disabled Bit 2 = 1: Enable General-purpose I/O Port C2 Trigger Wakeup MCU function; 0: Function disabled Bit 1 = 1: Enable General-purpose I/O Port C1 Trigger Wakeup MCU function; 0: Function disabled Bit 0 = 1: Enable General-purpose I/O Port C0 Trigger Wakeup MCU function; 0: Function disabled

∴ unimplemented.

**Peripheral Interrupt Wakeup Control Register PERIPHERAL\_WK (XFR: 0x64)      Reset Value: 00h**

Bit	Bit 7	Bit 6	Bit 5	Bit 4	Bit 3	Bit 2	Bit 1	Bit 0
Status	R/W	R/W	R/W	R/W	R/W	R/W	R/W	-
Name	INT_WK[3:0]				ADC_WK	ACOMP_WK	WTMR_WK	Reserved

Bit Number	Bit Mnemonic	Description
7-4	INT_WK[3:0]	External 8052 INT0/1/2/3 Wakeup MCU Enable setting Bit 7 = 1: Enable 8052 INT3 Wakeup MCU function; 0: function disabled Bit 6 = 1: Enable 8052 INT2 Wakeup MCU function; 0: function disabled Bit 5 = 1: Enable 8052 INT1 Wakeup MCU function; 0: function disabled Bit 4 = 1: Enable 8052 INT0 Wakeup MCU function; 0: function disabled

Bit Number	Bit Mnemonic	Description
3	ADC_WK	ADC Compare mode Wakeup MCU Enable setting 1: Enable Wakeup MCU function after ADC comparing is complete 0: Disable Wakeup MCU function after ADC comparing is complete
2	ACOMP_WK	Comparator Wakeup MCU Enable setting 1: Enable Wakeup MCU function after Comparator is triggered 0: Disable Wakeup MCU function after Comparator is triggered
1	WTMR_WK	Watch Timer Wakeup MCU Enable setting 1: Enable Watch Timer Wakeup MCU function after Watch Timer is triggered 0: Disable Watch Timer Wakeup MCU function after Watch Timer is triggered
0	Reserved	-

:- unimplemented.

**General-purpose I/O Port A Wakeup Flag Register GPIOA\_TOG[5:0] (XFR: 0x65)      Reset Value: 00h**

Bit	Bit 7	Bit 6	Bit 5	Bit 4	Bit 3	Bit 2	Bit 1	Bit 0
Status	-	-	R	R	R	R	R	R
Name	Reserved		GPIOA_TOG[5:0]					

Bit Number	Bit Mnemonic	Description
7-6	Reserved	-
5-0	GPIOA_TOG[5:0]	General-purpose I/O Port A Trigger Wakeup Flag. If the corresponding bit Toggle Trigger occurred, Wakeup Flag Bit = 1 Bit 5: I/O Port A5 Wakeup Flag Bit 4: I/O Port A4 Wakeup Flag Bit 3: I/O Port A3 Wakeup Flag Bit 2: I/O Port A2 Wakeup Flag Bit 1: I/O Port A1 Wakeup Flag Bit 0: I/O Port A0 Wakeup Flag

:- unimplemented.

**General-purpose I/O Port B Wakeup Flag Register GPIOB\_TOG[5:0] (XFR: 0x66)      Reset Value: 00h**

Bit	Bit 7	Bit 6	Bit 5	Bit 4	Bit 3	Bit 2	Bit 1	Bit 0
Status	-	-	R	R	R	R	R	R
Name	Reserved		GPIOB_TOG[5:0]					

Bit Number	Bit Mnemonic	Description
7-6	Reserved	-
5-0	GPIOB_TOG[5:0]	General-purpose I/O Port B Trigger Wakeup Flag. If the corresponding bit Toggle Trigger occurred, Wakeup Flag Bit = 1 Bit 5: I/O Port B5 Wakeup Flag Bit 4: I/O Port B4 Wakeup Flag Bit 3: I/O Port B3 Wakeup Flag Bit 2: I/O Port B2 Wakeup Flag Bit 1: I/O Port B1 Wakeup Flag Bit 0: I/O Port B0 Wakeup Flag

:- unimplemented.

**General-purpose I/O Port C Wakeup Flag Register GPIOC\_TOG[5:0] (XFR: 0x67)      Reset Value: 00h**

Bit	Bit 7	Bit 6	Bit 5	Bit 4	Bit 3	Bit 2	Bit 1	Bit 0
Status	-	-	R	R	R	R	R	R
Name	Reserved		GPIOC_TOG[5:0]					

Bit Number	Bit Mnemonic	Description
7-6	Reserved	-
5-0	GPIOC_TOG[5:0]	General-purpose I/O Port C Trigger Wakeup Flag. If the corresponding bit Toggle Trigger occurred, Wakeup Flag Bit = 1 Bit 5: I/O Port C5 Wakeup Flag Bit 4: I/O Port C4 Wakeup Flag Bit 3: I/O Port C3 Wakeup Flag Bit 2: I/O Port C2 Wakeup Flag Bit 1: I/O Port C1 Wakeup Flag Bit 0: I/O Port C0 Wakeup Flag

:- unimplemented.

**Peripheral Interrupt Wakeup Flag Register PERIPHERAL\_TOG (XFR: 0x69)      Reset Value: 00h**

Bit	Bit 7	Bit 6	Bit 5	Bit 4	Bit 3	Bit 2	Bit 1	Bit 0
Status	R	R	R	R	R	R	R	-
Name	INT_WK_EVT [3:0]				ADC_TOG	ACOMP_TOG	WTMR_EVT	Reserved

Bit Number	Bit Mnemonic	Description
7-4	INT_WK_EVT[3:0]	Interrupt Wakeup Flag Bit 7 = 1: MCU is woken up by INT3 interrupt Bit 6 = 1: MCU is woken up by INT2 interrupt Bit 5 = 1: MCU is woken up by INT1 interrupt Bit 4 = 1: MCU is woken up by INT0 interrupt
3	ADC_TOG	ADC Compare mode Trigger (Wakeup) Flag 1: A Trigger (Wakeup) occurred in ADC compare 0: A Trigger (Wakeup) not occurred in ADC compare
2	ACOMP_TOG	Comparator Trigger (Wakeup) Flag 1: A Trigger (Wakeup) occurred in Comparator 0: A Trigger (Wakeup) not occurred in Comparator
1	WTMR_EVT	Watch Timer Trigger (Wakeup) Flag 1: A Trigger (Wakeup) occurred in Watch Timer 0: A Trigger (Wakeup) not occurred in Watch Timer
0	Reserved	-

:- unimplemented.



**Wakeup Clear Register CLR\_IN\_TOG (XFR: 0x6A)**

**Reset Value: 00h**

Bit	Bit 7	Bit 6	Bit 5	Bit 4	Bit 3	Bit 2	Bit 1	Bit 0
Status	W	-	-	-	-	-	-	R
Name	CLR_IN_TOG	Reserved						IN_TOG

Bit Number	Bit Mnemonic	Description
7	CLR_IN_TOG	1: Clear all Input Toggle
6-1	Reserved	-
0	IN_TOG	1: All toggle events logic- or operation if any toggle source occurred, this bit will be set.

**-: unimplemented.**

**The setting of entering Sleep Mode and Wakeup procedure:**

1. Set RST\_NDF = 1
2. Enable Watchdog Timer (DIS\_WDT[7:5] = 101)
3. Select Wakeup sources:

Wakeup Sources		Sleep Mode	Idle Mode	
		No Clock	Sub: 32 kHz	Main: 12 MHz
1.	NRST pin is low voltage	•	•	•
2.	External Interrupt INT0/1/2 sources			
	> SPI interrupt			•
	> Comparator interrupt			•
	> Low Voltage Detection interrupt	•	•	•
	> Watch Timer interrupt		•	•
	> Enhanced Timer/Counter interrupt			•
	> 18 General-purpose I/O pin Toggle interrupt			•
3.	External interrupt INT3 sources (GPIO A/B/C)			
	> 16 IRQ interrupt pins			•
4.	18 General-purpose I/O pin Toggle interrupt (GPIO A/B/C)	•	•	•
5.	ADC_WK (Compare Mode)	•	•	•
6.	ACOMP_WK	•	•	•
7.	WTMR_WK	•	•	•

4. Clear all input Trigger Wakeup (CLR\_IN\_TOG = 1)
5. Select internal 12 MHz RC oscillator as SOURCE clock (SOURCE\_CLK\_SLT[1:0] = 00)
6. Entering Sleep Mode (SOURCE\_CLK\_OFF = 1)
7. Wait for Wakeup Trigger
  - SOURCE clock = IRC 12M, needs to wait for 128 clock cycles to return to the main program
  - SOURCE clock = Crystal, needs to wait for 16 x 1024 clock cycles to return to the main program

## 6.8 12 MHz RC Oscillator Calibration

WT51F104 has a built-in 12 MHz RC oscillator to reduce the cost of external crystal oscillator. For more precise system clock, external crystal oscillator 12 MHz is available. In addition, it is a better choice to use 32.768 kHz (crystal oscillator) to calibrate internal RC 12 MHz oscillators. (Calibration can reach  $\pm 1\%$  at  $-40^{\circ}\text{C} \sim +85^{\circ}\text{C}$ )

### Internal Oscillator Adjust Register RC\_LADJ (XFR: 0x70)

**Reset Value: 40h**

Bit	Bit 7	Bit 6	Bit 5	Bit 4	Bit 3	Bit 2	Bit 1	Bit 0
Status	-	R/W	R/W	R/W	R/W	R/W	R/W	R/W
Name	Reserved	RC_LADJ_C[2:0]			RC_LADJ_F[3:0]			

Bit Number	Bit Mnemonic	Description
7	Reserved	-
6-4	RC_LADJ_C[2:0]	Each level 8% coarse adjustment of the Internal RC oscillator frequency (default value '100'), 7 levels in total
3-0	RC_LADJ_F[3:0]	Each level 0.5% fine adjustment of the Internal RC oscillator frequency (default value '1000'), 15 levels in total

-: unimplemented.

**Note:** Internal Oscillator Adjustment Register RC\_LADJ\_C[2:0] & RC\_LADJ\_F[3:0] is allowed to adjust the control circuit of IRC 12 MHz directly.

### Internal Oscillator Counter Data High Bytes Register RC12M\_CNT[9:2] (XFR: 0x71)

**Reset Value: 00h**

Bit	Bit 7	Bit 6	Bit 5	Bit 4	Bit 3	Bit 2	Bit 1	Bit 0
Status	R	R	R	R	R	R	R	R
Name	RC12M_CNT[9:2]							

Bit Number	Bit Mnemonic	Description
7-0	RC12M_CNT[9:2]	The counting value RC12M_CNT[9:2] of internal 12 MHz RC oscillator, is paired with RC12M_CNT[1:0] to form a 10-bit counting value

### Internal Oscillator Counter Data Low Bytes Register RC12M\_CNT[1:0] (XFR: 0x72)

**Reset Value: 00h**

Bit	Bit 7	Bit 6	Bit 5	Bit 4	Bit 3	Bit 2	Bit 1	Bit 0
Status	-	-	-	-	-	-	R	R
Name	Reserved						RC12M_CNT[1:0]	

Bit Number	Bit Mnemonic	Description
7-2	Reserved	-
1-0	RC12M_CNT[1:0]	The counting value RC12M_CNT[1:0] of internal 12 MHz RC oscillator, is paired with RC12M_CNT[9:2] to form a 10-bit counting value

-: unimplemented.

**Internal Oscillator Calibration Control Register RC\_CALIB\_EN (XFR: 0x73)**

**Reset Value: 00h**

Bit	Bit 7	Bit 6	Bit 5	Bit 4	Bit 3	Bit 2	Bit 1	Bit 0
Status	R/W	-	R/W	-	-	-	-	-
Name	RC_CALIB_EN	Reserved	AUTO_CAL_EN	Reserved				

Bit Number	Bit Mnemonic	Description
7	RC_CALIB_EN	Enable RC Oscillator Calibration function
6	Reserved	-
5	AUTO_CAL_EN	1: Enable H/W automatic calibration function
4-0	Reserved	-

**-: unimplemented.**

**Note:**

**Manual calibration: enable RC\_CALIB\_EN, and is working together with Firmware.**

**Automatic calibration: enable RC\_CALIB\_EN and AUTO\_CAL\_EN.**

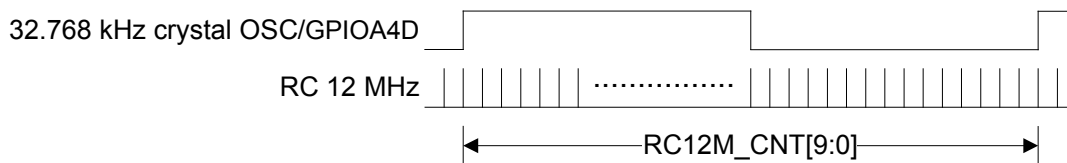

**Calibration Theory:**

When the external 32.768 kHz oscillator is used, it is available to count in the fixed width of precise 32.768 kHz by internal RC 12 MHz. Then with the counting value we got, we can make a compensation by the Control Internal Oscillator Adjust Registers RC\_LADJ\_C [2:0] & RC\_LADJ\_F [3:0], reaching  $\pm 1\%$  at room temperature.

**The range of coarse adjustment and fine adjustment:**

Coarse adjustment: the actual internal RC frequency  $\pm$  (internal RC frequency \* 0.08); RC\_LADJ\_C[2:0] ranges from 000 ~ 111, and the middle value is 100.

Fine adjustment: the actual internal RC frequency  $\pm$  (internal RC frequency \* 0.005); RC\_LADJ\_F[3:0] ranges from 0000 ~ 1111, and the middle value is 1000.

RC12M_CNT[9:0]	External 32.768 kHz Sampled (Hz)	Target Value (Hz)	Tolerance %
360	11796480	12000000	+1.70
361	11829248	12000000	+1.42
362	11862016	12000000	+1.15
363	11894784	12000000	+0.88
364	11927552	12000000	+0.60
365	11960320	12000000	+0.33
366	11993088	12000000	+0.06
367	12025856	12000000	-0.22
368	12058624	12000000	-0.49
369	12091392	12000000	-0.76
370	12124160	12000000	-1.03

**Note:**

1. When WT51F104 is waken up from sleep mode (RC bias is turned on), RC oscillator calibration function needs to wait for at least 83.3ns (at 12 MHz) to return to normal mode.
2. As soon as the RC oscillator calibration function is enabled, read RC12M\_CNT[9:2] & RC12M\_CNT[1:0] register twice, then confirm the data is the same then the calibration can proceed.
3. If RC12M\_CNT[9:0] internal oscillator counter data register is 511 (0x1FF), indicating that no external oscillator or without enabling external oscillator.
4. When reset, WT51F104 will auto-reload the calibration value of RC 12 MHz into internal oscillator adjustment register (XFR: 0x70).
5. When enable AUTO\_CAL\_EN & the external 32.768 kHz oscillator of MCU is also oscillated, MCU will auto calibrate once every 30.5us.  
(Condition: CRY\_12M\_PD, IRC\_12M\_PD1 & IRC\_12M\_PD2 cannot be turned off).

## 6.9 Watchdog Timer and Watch Timer

### 6.9.1 Watchdog Timer (WDT)

Watchdog Timer can be used to detect CPU failures, such as the software deadlock circles caused by noises, voltage disturbance, or power off etc. When an internal counter of the Watchdog Timer overflows, a reset signal will be generated then reset the CPU.

Watchdog Timer is not similar to the general-purpose 8052 Timer 0/1/2. To prevent a reset occurred on Watchdog Timer, which can be cleared by software before important path of program. When unpredictable reset occurred, user should check the WDT\_RST\_FLG bit in Reset Flag Register to judge if the previous reset is occurred by Watchdog Timer.

- Clock sources of Watchdog Timer: Internal 32 kHz, or External 32.768 kHz Crystal Oscillator
- Reset Time: 16 ms, 32 ms, 1.024 S, 2.048 S

#### Watchdog Timer Control Register WDT\_CTL (XFR: 0x78)

**Reset Value: 02h**

Bit	Bit 7	Bit 6	Bit 5	Bit 4	Bit 3	Bit 2	Bit 1	Bit 0
Status	R/W	R/W	R/W	-	-	-	R/W	R/W
Name	DIS_WDT[2:0]			Reserved			WDT_TM_SLT[1:0]	

Bit Number	Bit Mnemonic	Description
7-5	DIS_WDT[2:0]	Watchdog Timer switch 101: Disable Watchdog Timer at the same time clear counts Other value: Enable Watchdog Timer
4-2	Reserved	-
1-0	WDT_TM_SLT[1:0]	Watchdog Reset Time setting When the Watchdog uses internal RC 32 kHz oscillator: 00: 16 ms 01: 32 ms 10: 1.024 S 11: 2.048 S  When the Watchdog uses external 32.768 kHz Crystal Oscillator: 00: 15.625 ms 01: 31.25 ms 10: 1 S 11: 2 S

-: unimplemented.

Note:

1. The frequency tolerance of internal 32 kHz RC oscillator is about  $\pm 30\%$ .
2. The Watchdog Timer clock sources can be selected by the bit WDT\_CLK\_SLT of System Control Register (XFR: 0x01), with details as below.

**System Control Register SYS\_CTL (XFR: 0x01)**
**Reset Value: 80h**

Bit	Bit 7	Bit 6	Bit 5	Bit 4	Bit 3	Bit 2	Bit 1	Bit 0
Status	R/W	R/W	R/W	-			R/W	R/W
Name	RST_NDF	LVR_PD	EN_PC_OVL_RST	Reserved			WDT_CLK_SLT	WTMR_CLK_SLT

Bit Number	Bit Mnemonic	Description
7	RST_NDF	1: NRST pin without digital filter function in 0: NRST pin with digital filter function (4 clocks)
6	LVR_PD	1: Turn off low voltage reset power 0: Turn on low voltage reset power
5	EN_PC_OVL_RST	1: Enable program counter overflow reset 0: Disable program counter overflow reset
4-2	Reserved	-
1	WDT_CLK_SLT	1: Watchdog Timer uses external 32.768 kHz crystal oscillator 0: Watchdog Timer uses internal 32 kHz RC oscillator
0	WTMR_CLK_SLT	1: Watch Timer uses external 32.768 kHz crystal oscillator 0: Watch Timer uses internal 32 kHz RC oscillator

**-: unimplemented.**
**Note: If WDT\_CLK\_SLT = 1 or WTMR\_CLK\_SLT = 1, must enable EN\_CRY\_DIV and set CRY\_DIV[9:0] at the same time, and let the Watchdog Timer and Watch Timer use the precise clock source 32 kHz.**
**External Clock Source Prescaler Control Register 1 CRY\_DIV[9:8] (XFR: 0x09)**
**Reset Value: 01h**

Bit	Bit 7	Bit 6	Bit 5	Bit 4	Bit 3	Bit 2	Bit 1	Bit 0
Status	R/W	-	-	-	-	-	R/W	R/W
Name	EN_CRY_DIV	Reserved					CRY_DIV[9:8]	

Bit Number	Bit Mnemonic	Description
7	EN_CRY_DIV	1: Enable the clock source prescaler of external crystal oscillator 0: Disable the clock source prescaler of external crystal oscillator
6-2	Reserved	-
1-0	CRY_DIV[9:8]	The prescaler data [9:8] of external Crystal Oscillator Clock source, is paired with CRY_DIV[7:0] to form a 10-bit prescaler data

**-: unimplemented.**

**External Clock Source Prescaler Control Register 2 CRY\_DIV[7:0] (XFR: 0x0A) Reset Value: 76h**

Bit	Bit 7	Bit 6	Bit 5	Bit 4	Bit 3	Bit 2	Bit 1	Bit 0
Status	R/W	R/W	R/W	R/W	R/W	R/W	R/W	R/W
Name	CRY_DIV[7:0]							

Bit Number	Bit Mnemonic	Description
7-0	CRY_DIV[7:0]	The prescaler data [7:0] of external Crystal Oscillator Clock source, is paired with CRY_DIV[9:8] to form a 10-bit prescaler data

Note: When enable EN\_CRY\_DIV, CRY\_DIV[9:0] cannot be 0, otherwise MCU will not work.

**Examples:**

1. If the clock source is External 24 MHz crystal oscillator, and the Watchdog Timer and Watch Timer use the clock source with low tolerance frequency (for precise time base), then the External Clock Source Prescaler Control Register must be enabled and the prescaler data is required.
  1. Setting prescaler data:  $CRY\_DIV[9:0] = 731$ ;  $24\text{ MHz} / (CRY\_DIV[9:0] + 1) = 24\text{ MHz} / 732 = 32.768\text{ kHz}$
  2. Enable clock source prescaler of external crystal oscillator:  $EN\_CRY\_DIV = 1$
  3. Select External oscillator as the clock source of Watchdog Timer & Watch Timer:  $WDT\_CLK\_SLT = 1$ ;  $WTMR\_CLK\_SLT = 1$
  
2. If the clock source is External 12 MHz crystal oscillator, and the Watchdog Timer and Watch Timer use the clock source with low tolerance frequency (for precise time base), then the External Clock Source Prescaler Control Register must be enabled and the prescaler data is required.
  1. Setting prescaler data:  $CRY\_DIV[9:0] = 365$ ;  $12\text{ MHz} / (CRY\_DIV[9:0] + 1) = 12\text{ MHz} / 366 = 32.768\text{ kHz}$
  2. Enable clock source prescaler of external crystal oscillator:  $EN\_CRY\_DIV = 1$
  3. Select External oscillator as the clock source of Watchdog Timer & Watch Timer:  $WDT\_CLK\_SLT = 1$ ;  $WTMR\_CLK\_SLT = 1$
  
3. If the clock source is Internal 32 kHz, and the Watchdog Timer and Watch Timer use 32.768 kHz crystal oscillator as the clock source, then the External Clock Source Prescaler Control Register must be enabled and the prescaler data is required.
  1. Setting prescaler data:  $CRY\_DIV[9:0] = 1$ ;  $32.768\text{ kHz} / (CRY\_DIV[9:0] + 1) = 32.768\text{ kHz} / 2 = 16.384\text{ kHz}$
  2. Enable clock source prescaler of external crystal oscillator:  $EN\_CRY\_DIV = 1$
  3. Select External oscillator as the clock source of Watchdog Timer & Watch Timer:  $WDT\_CLK\_SLT = 1$ ;  $WTMR\_CLK\_SLT = 1$



### 6.9.2 Watch Timer

The application functions of Watch Timer include Timer Interrupt, Timer Wakeup, Timer ADC and so on.

- The clock source of Watch Timer is 32 kHz internal RC oscillator or 32.768 kHz external oscillator. By this clock source, it can generate 8 Time bases

#### Watch Timer Control Register WTMR\_CTL (XFR: 0x7C)

Reset Value: 80h

Bit	Bit 7	Bit 6	Bit 5	Bit 4	Bit 3	Bit 2	Bit 1	Bit 0
Status	R/W	R	W	-	-	-	-	-
Name	DIS_WTMR	WTMR_EVT	CLR_WTMR_EVT	Reserved				

Bit Number	Bit Mnemonic	Description
7	DIS_WTMR	1: Disable Watch Timer 0: Enable Watch Timer
6	WTMR_EVT	1: Indicates Watch Timer Event (as the Watch Timer counting reaches the setting time of WTMR[2:0]) 0: Cleared by CLR_WTMR_EVT = 1
5	CLR_WTMR_EVT	1: Clear Watch Timer event, and then WTMR_EVT = 0
4-0	Reserved	-

-: unimplemented.

#### Watch Timer Output Selection Register WTMR\_SLT[2:0] (XFR: 0x7D)

Reset Value: 00h

Bit	Bit 7	Bit 6	Bit 5	Bit 4	Bit 3	Bit 2	Bit 1	Bit 0
Status	-	-	-	-	-	R/W	R/W	R/W
Name	Reserved					WTMR_SLT[2:0]		

Bit Number	Bit Mnemonic	Description
7-3	Reserved	-
2-0	WTMR_SLT[2:0]	Watch Timer Time base selection bit (If needs to be precise, using external Crystal Oscillator 32.768 kHz is recommended, please refer to section 6.9.1.) 000: Watch time = 3.91 ms 001: Watch time = 31.25 ms 010: Watch time = 62.50 ms 011: Watch time = 125 ms 100: Watch time = 0.25 S 101: Watch time = 0.5 S 110: Watch time = 1 S 111: Watch time = 2 S

-: unimplemented.

## 6.10 I<sup>2</sup>C Serial Interface

I<sup>2</sup>C module uses SCL (clock) and SDA (data) wires to connect with other I<sup>2</sup>C interfaces, the transmission is determined by the software programmed MI<sup>2</sup>C\_CLK [1:0] in XFR, and is allowed to reach 400KBps (maximum). I<sup>2</sup>C module also provides Master/Slave mode, and it is set by Register.

### Master/Slave I<sup>2</sup>C Control Register MI<sup>2</sup>C\_CTL (XFR: 0xA0)

**Reset Value: 40h**

Bit	Bit 7	Bit 6	Bit 5	Bit 4	Bit 3	Bit 2	Bit 1	Bit 0
Status	R/W	R/W	R/W	W	W	R/W	W	W
Name	MI <sup>2</sup> C_EN	MI <sup>2</sup> C_CLK[1:0]	MI <sup>2</sup> C_START	MI <sup>2</sup> C_STOP	MI <sup>2</sup> C_TXNAK	MI <sup>2</sup> C_CLR_RT	MI <sup>2</sup> C_CLR_STP	

Bit Number	Bit Mnemonic	Description
7	MI <sup>2</sup> C_EN	1: Enable I <sup>2</sup> C function 0: Disable I <sup>2</sup> C function
6-5	MI <sup>2</sup> C_CLK[1:0]	Select Master I <sup>2</sup> C Clock 00: SCL clock = 400 kHz at 12 MHz oscillator 01: SCL clock = 200 kHz at 12 MHz oscillator 10: SCL clock = 100 kHz at 12 MHz oscillator 11: SCL clock = 50 kHz at 12 MHz oscillator
4	MI <sup>2</sup> C_START	1: Enable I <sup>2</sup> C Transmit Start bit 0: Disable I <sup>2</sup> C Transmit Start bit
3	MI <sup>2</sup> C_STOP	1: Enable I <sup>2</sup> C Transmit Stop bit 0: Disable I <sup>2</sup> C Transmit Stop bit
2	MI <sup>2</sup> C_TXNAK	Master I <sup>2</sup> C Transmit ACK bit after next Rx state 1: Transmit NACK 0: Transmit ACK
1	MI <sup>2</sup> C_CLR_RT	1: Clear Transmit and Receive interrupt
0	MI <sup>2</sup> C_CLR_STP	1: Clear Slave mode Stop status interrupt

**Note:** When changing the speed of master I<sup>2</sup>C, it requires 10us (SOURCE clock is 12 MHz) to stabilize the internal reference clock, and then the master I<sup>2</sup>C can go back to work.

### Master/Slave I<sup>2</sup>C Status Register MI<sup>2</sup>C\_STA (XFR: 0xA1)

**Reset Value: 00h**

Bit	Bit 7	Bit 6	Bit 5	Bit 4	Bit 3	Bit 2	Bit 1	Bit 0
Status	R	R	R	R	R	R	R	-
Name	MI <sup>2</sup> C_RDY	MI <sup>2</sup> C_INT_RT	MI <sup>2</sup> C_INT_STOP	MI <sup>2</sup> C_BB	MI <sup>2</sup> C_FIRST	MI <sup>2</sup> C_RW	MI <sup>2</sup> C_RXNAK	Reserved

Bit Number	Bit Mnemonic	Description
7	MI <sup>2</sup> C_RDY	When bit = 1, Interrupt status when I <sup>2</sup> C Receive/Transmit the 9 <sup>th</sup> bit or Slave Stop phase
6	MI <sup>2</sup> C_INT_RT	When bit = 1, Interrupt status when I <sup>2</sup> C Receive/Transmit the 9 <sup>th</sup> bit
5	MI <sup>2</sup> C_INT_STOP	When bit = 1, Interrupt status when I <sup>2</sup> C Slave mode Stop phase
4	MI <sup>2</sup> C_BB	When bit = 1, Slave mode bus busy

Bit Number	Bit Mnemonic	Description
3	MI <sup>2</sup> C_FIRST	Slave mode First phase. This is the first byte from Master I <sup>2</sup> C with specific Slave Address.
2	MI <sup>2</sup> C_RW	When bit = 1, Slave mode Read/Write Phase (the 8 <sup>th</sup> bit of the first byte) 1: Slave I <sup>2</sup> C as Transmit mode 0: Slave I <sup>2</sup> C as Receive mode
1	MI <sup>2</sup> C_RXNAK	ACK bit indicator when I <sup>2</sup> C in Slave Tx mode 1: Master mode return NACK (Slave will pull SAD high) 0: Master mode return ACK
0	Reserved	-

-: unimplemented.

**Master/Slave I<sup>2</sup>C Transmit Buffer Register MI<sup>2</sup>C\_DSLV[7:0] (XFR: 0xA2)**
**Reset Value: 00h**

Bit	Bit 7	Bit 6	Bit 5	Bit 4	Bit 3	Bit 2	Bit 1	Bit 0
Status	R/W	R/W	R/W	R/W	R/W	R/W	R/W	R/W
Name	MI <sup>2</sup> C_DSLV[7:0]							

Bit Number	Bit Mnemonic	Description
7-0	MI <sup>2</sup> C_DSLV[7:0]	Master I <sup>2</sup> C transmit slave address buffer

**Master/Slave I<sup>2</sup>C Transmit and Receive Buffer Register MI<sup>2</sup>C\_DTRX[7:0] (XFR: 0xA3)**
**Reset Value: FFh**

Bit	Bit 7	Bit 6	Bit 5	Bit 4	Bit 3	Bit 2	Bit 1	Bit 0
Status	R/W	R/W	R/W	R/W	R/W	R/W	R/W	R/W
Name	MI <sup>2</sup> C_DTRX[7:0]							

Bit Number	Bit Mnemonic	Description
7-0	MI <sup>2</sup> C_DTRX[7:0]	W: When Tx work as I <sup>2</sup> C transmit buffer R: When Rx work as I <sup>2</sup> C receive buffer

**Slave I<sup>2</sup>C Address Register MI<sup>2</sup>C\_SADR (XFR: 0xA4)**
**Reset Value: 00h**

Bit	Bit 7	Bit 6	Bit 5	Bit 4	Bit 3	Bit 2	Bit 1	Bit 0
Status	R/W	R/W	R/W	R/W	R/W	R/W	R/W	R/W
Name	MI <sup>2</sup> C_SADR							MI <sup>2</sup> C_SLVE

Bit Number	Bit Mnemonic	Description
7-1	MI <sup>2</sup> C_SADR	The slave address
0	MI <sup>2</sup> C_SLVE	I <sup>2</sup> C slave mode enable 1: I <sup>2</sup> C as Slave 0: I <sup>2</sup> C as Master

**Master/Slave I<sup>2</sup>C Extended Control Register MI<sup>2</sup>C\_EXTEND (XFR: 0xA5)**

**Reset Value: 00h**

Bit	Bit 7	Bit 6	Bit 5	Bit 4	Bit 3	Bit 2	Bit 1	Bit 0
Status	-	-	-	-	-	-	R/W	R/W
Name	Reserved						MI <sup>2</sup> C_AUTOSTP	MI <sup>2</sup> C_WAIT

Bit Number	Bit Mnemonic	Description
7-2	Reserved	-
1	MI <sup>2</sup> C_AUTOSTP	Enable Master I <sup>2</sup> C auto transmit stop bit, when receive NACK Bit
0	MI <sup>2</sup> C_WAIT	Enable Master/Slave I <sup>2</sup> C pull SCL low after the 9 <sup>th</sup> bit

**-: unimplemented.**

If the firmware processing time is slower than the time of I<sup>2</sup>C receiving 9 bits, then the firmware must set MI<sup>2</sup>C\_WAIT enabling WT51F104 to pull SCL low after the 9<sup>th</sup> bit.

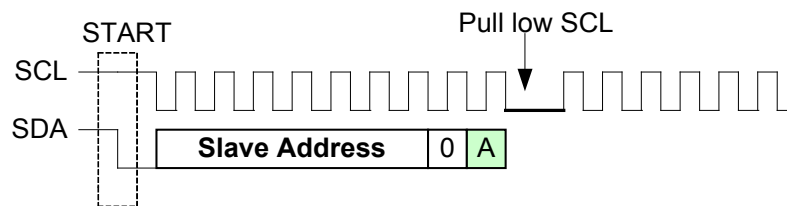

**WT51F104 Master/Slave I<sup>2</sup>C Data Flow**

**(1) Master write mode :**

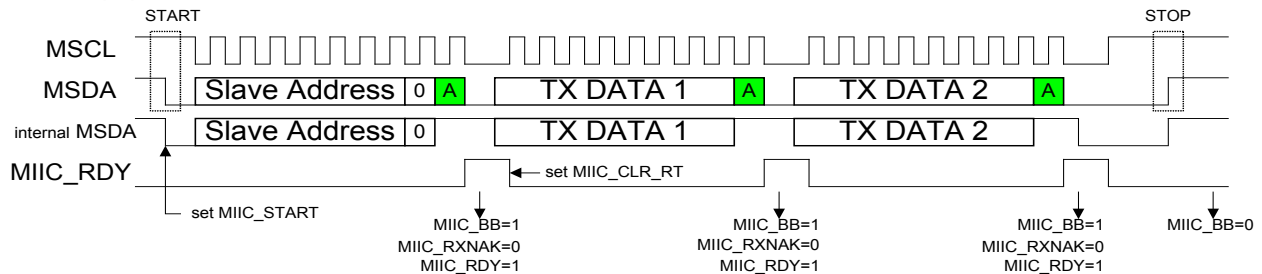

**(2) Master read mode :**

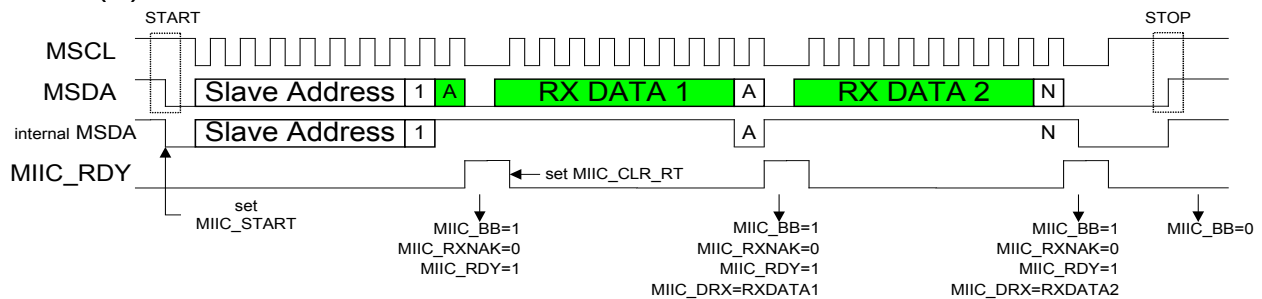

**(3) Slave write mode :**

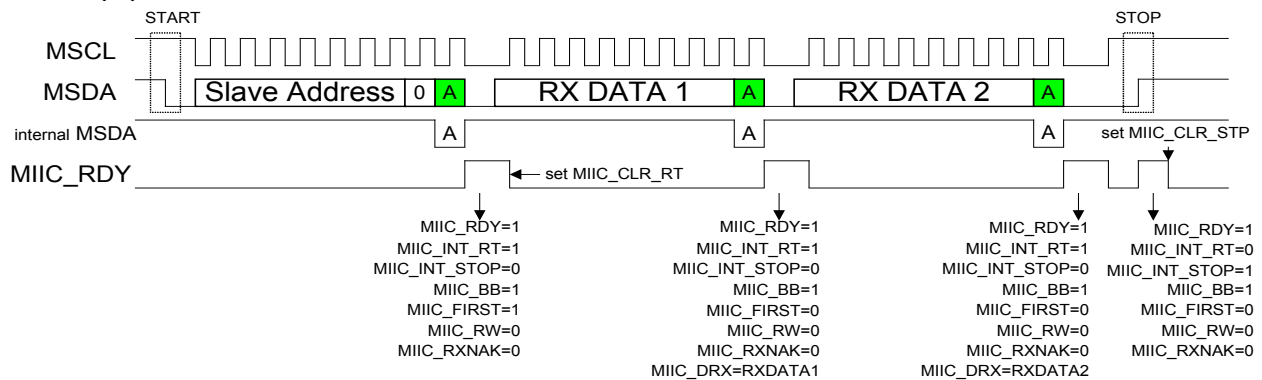

**(4) Slave read mode :**

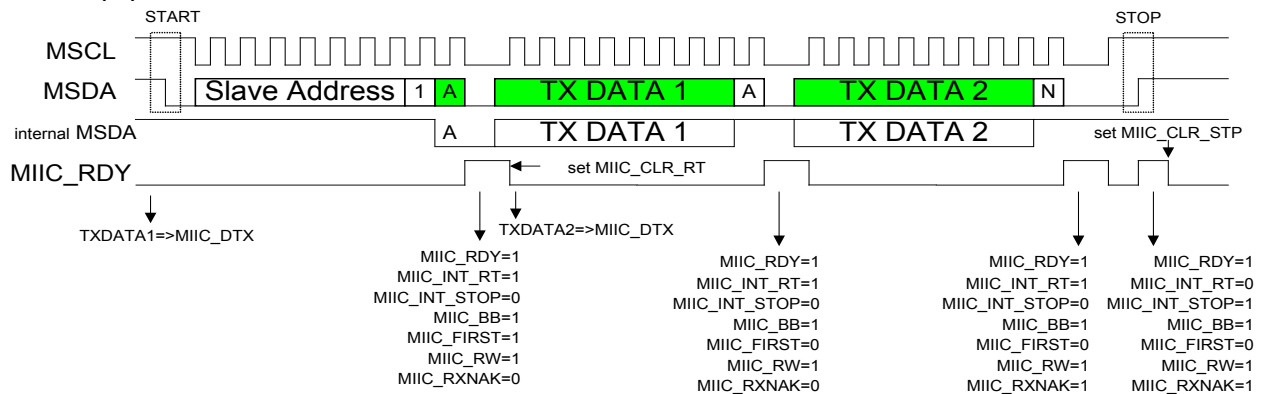



## 6.11 Enhanced Timer/Counter

The clock sources of enhanced Timer/Counter are from internal or external clock, and it is determined by register. The Enhanced Timer/Counter has two operation modes: 1. Compare mode. 2. Capture mode. Furthermore there are three types of Capture Match condition for selection: High-level, Low-level, and Period of Capture mode.

### 1. Compare mode:

The Enhanced Timer/Counter contains one 16-bit Counter and one 16-bit enhanced Buffer (ETM\_BUF[15:0]). When enable the Enhanced Timer/Counter (EN\_ETM = 1) and set as the compare mode (ETM\_CNT\_TM = 1), the counter will start counts according to the clock sources, and an interrupt will occur once the data of the counter matches the data of the enhanced Buffer. Each match will output the trigger of ETMO (function not available) and clear the counter value of the internal 16-bit Counter. Please refer to the figure below.

Compare mode operation flow:

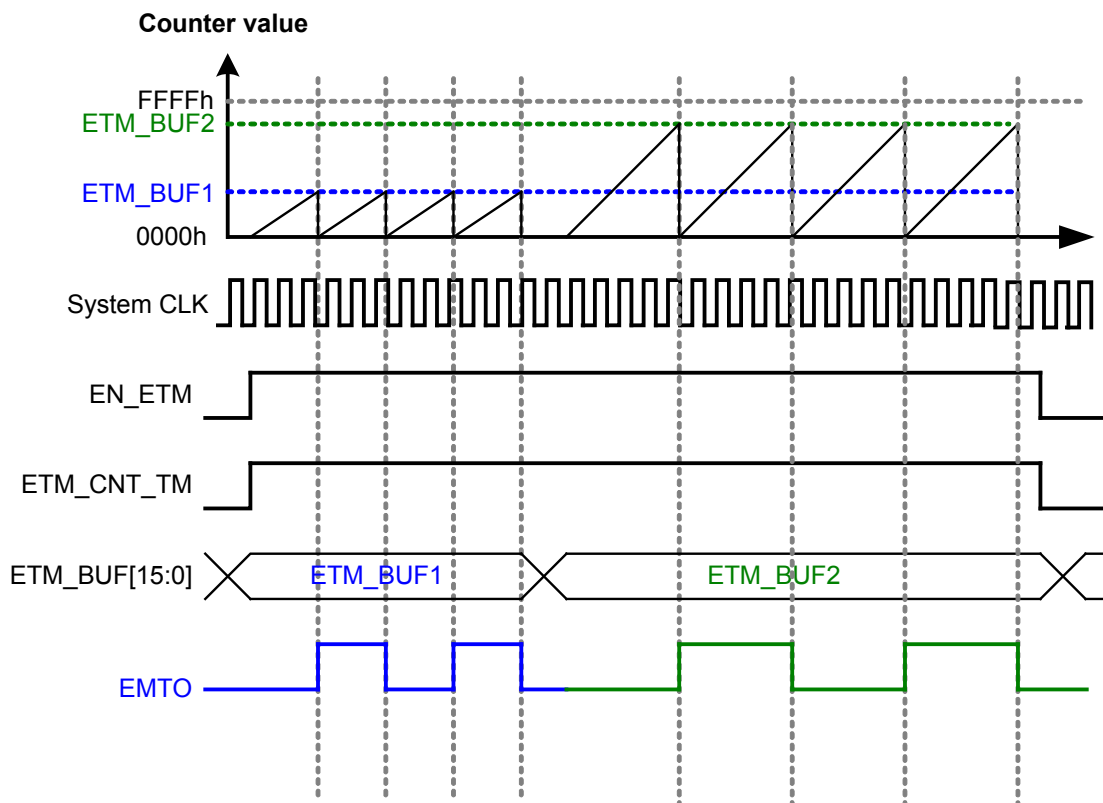

## 2. Capture mode:

If the Enhanced Timer/Counter is set as the Capture mode (ETM\_CNT\_TM = 0), and it is enabled (EN\_ETM = 1), the capture operation starts. When the input status changes then match with the setting capture condition, the internal 16-bit counter will be cleared and restarts counting, then reload the counter value into 16-bit Buffer (ETM\_BUF[15:0]) automatically. At the same time, the software can read the counter value from the Enhanced Timer/Counter Data Buffer Register (register B3H & B4H), and a capture interrupt, capture flag and output ETM0 may be generated (function not available). Please refer to the figure below.

### Capture mode operation flow:

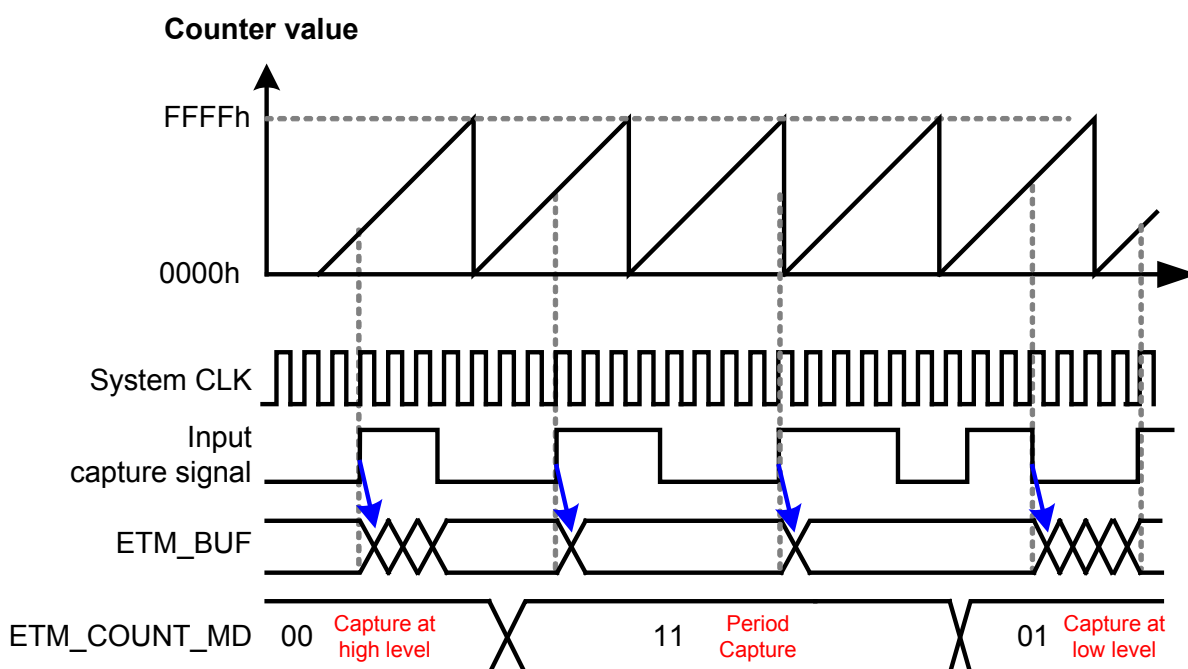

### Enhanced Timer/Counter Control Register 1 ETM\_CTL1 (XFR: 0xB0)

Reset Value: 00h

Bit	Bit 7	Bit 6	Bit 5	Bit 4	Bit 3	Bit 2	Bit 1	Bit 0
Status	R/W	R/W	R/W	R/W	R/W	R/W	R/W	R/W
Name	EN_ETM	ETM_CNT_TM	ETM_CLK_PSCAL[1:0]		ETM_CLK_SEL	ETM_EXCLK_SEL[1:0]		ETM_CLK_DIV12

Bit Number	Bit Mnemonic	Description
7	EN_ETM	1: Enable Enhanced Timer/Counter
6	ETM_CNT_TM	1: Compare mode (SOURCE clock = 12 MHz) 0: Capture mode (capture)



Bit Number	Bit Mnemonic	Description
5-4	ETM_CLK_PSCAL[1:0]	Set clock source prescalers of the internal 16-bit Counter 00: Enhanced Timer / Counter clock source = SOURCE clock / 1 01: Enhanced Timer / Counter clock source = SOURCE clock / 4 10: Enhanced Timer / Counter clock source = SOURCE clock / 8 11: Choose Timer/Counter clock base SOURCE clock/16 or SOURCE clock/12 (ETM_CLK_DIV12: 0 -> SOURCE clock/16; ETM_CLK_DIV12: 1 -> SOURCE clock /12)
3	ETM_CLK_SEL	Set Enhanced Timer/Counter clock source 1: External clock source (can select the input clock source by ETM_EXCLK_SEL[1:0]) 0: Internal clock source (SOURCE clock)
2-1	ETM_EXCLK_SEL[1:0]	Set Enhanced Timer/Counter input external clock source channel 00: GPIOA4 (set GPIOA4DH as GPIO input, GPA4_FUN_SLT[2:0] = 000) 01: GPIA3 (set GPIA3D as GPIO input, GPA3_FUN_SLT[2:0] = 000) 10: GPIOA2 (set GPIOA2DH as GPIO input, GPA2_FUN_SLT[2:0] = 000) 11: ACOMP_TGATE_O (internal signal, refer to section 6.14)
0	ETM_CLK_DIV12	1: SOURCE clock/12 0: SOURCE clock/16

-: unimplemented.

**Note:** If the external clock source channel of the Enhanced Timer/Counter input is one of the GPIOA4, GPIA3, or GPIOA2, and then the GPIO complex function must be set as GPIO and I/O port being input status.

**Enhanced Timer/counter Control Register 2 ETM\_CTL2 (XFR: 0xB1)**
**Reset Value: 00h**

Bit	Bit 7	Bit 6	Bit 5	Bit 4	Bit 3	Bit 2	Bit 1	Bit 0
Status	R/W	R/W	-	-	R/W	R/W	R/W	R/W
Name	ETM_IN_SOURCE[1:0]		Reserved		ETM_IN_PSCAL[1:0]		ETM_COUNT_MD[1:0]	

Bit Number	Bit Mnemonic	Description
7-6	ETM_IN_SOURCE[1:0]	Set Enhanced Timer/Counter input compare or capture channel 00: GPIOA4 (set GPIOA4DH as GPIO input, GPA4_FUN_SLT[2:0] = 000) 01: GPIA3 (set GPIA3D as GPIO input, GPA3_FUN_SLT[2:0] = 000) 10: GPIOA2 (set GPIOA2DH as GPIO input, GPA2_FUN_SLT[2:0] = 000) 11: ACOMP_TGATE_O (internal signal, refer to section 6.13)
5-4	Reserved	-
3-2	ETM_IN_PSCAL[1:0]	Set input channel period prescaler 00: Input period / 1 01: Input period / 4 10: Input period / 8 11: Input period / 16

Bit Number	Bit Mnemonic	Description
1-0	ETM_COUNT_MD[1:0]	Capture counting mode selection 00: Capture the interval of high level 01: Capture the interval of low level 1x: Capture the interval period (based on the setting ETM_IN_PSCAL[1:0] to capture)

:- unimplemented.

**Note:** If the external clock source channel of the Enhanced Timer/Counter input is one of the GPIOA4, GPIOA3, or GPIOA2, and then the GPIO complex function must be set as GPIO and I/O port being input status.

**Enhanced Timer/Counter Interrupt Register ETM\_INT (XFR: 0xB2)**
**Reset Value: 00h**

Bit	Bit 7	Bit 6	Bit 5	Bit 4	Bit 3	Bit 2	Bit 1	Bit 0
Status	R/W	R/W	R/W	R/W	R	R	R	-
Name	EN_CAPINT	EN_OVRINT	EN_CMPINT	CLR_FLAG	CAPF	OVRF	CPMF	Reserved

Bit Number	Bit Mnemonic	Description
7	EN_CAPINT	1: Enable input capture interrupt 0: Disable input capture interrupt
6	EN_OVRINT	1: Enable overflow interrupt 0: Disable overflow interrupt
5	EN_CMPINT	1: Enable Compare Match Interrupt 0: Disable Compare Match Interrupt
4	CLR_FLAG	1: Clear all Enhanced Timer/Counter flags
3	CAPF	Input capture flag
2	OVRF	Overflow flag When an overflow occurred in internal 16-bit counter, OVRF = 1
1	CPMF	Compare match flag When internal 16-bit counter has the same value as ETM_BUF, CPMF = 1
0	Reserved	-

:- unimplemented.

**Enhanced Timer/Counter Data Buffer Low Bytes Register ETM\_BUF[7:0] (XFR: 0xB3)**
**Reset Value: 00h**

Bit	Bit 7	Bit 6	Bit 5	Bit 4	Bit 3	Bit 2	Bit 1	Bit 0
Status	R/W	R/W	R/W	R/W	R/W	R/W	R/W	R/W
Name	ETM_BUF[7:0]							

Bit Number	Bit Mnemonic	Description
7-0	ETM_BUF[7:0]	Paired with ETM_BUF[15:8] to form a 16-bit counter value Read: In Capture mode, the counter value of the captured input signal Write: In Compare mode, as the compare value to compare with the internal 16-bit counter

**Enhanced Timer/Counter Data Buffer High Bytes Register ETM\_BUF[15:8] (XFR: 0xB4) Reset Value: 80h**

Bit	Bit 7	Bit 6	Bit 5	Bit 4	Bit 3	Bit 2	Bit 1	Bit 0
Status	R/W	R/W	R/W	R/W	R/W	R/W	R/W	R/W
Name	ETM_BUF[15:8]							

Bit Number	Bit Mnemonic	Description
7-0	ETM_BUF[15:8]	Paired with ETM_BUF[7:0] to form a 16-bit counter value Read: In Capture mode, the counter value of the captured input signal Write: In Compare mode, as the compare value to compare with the internal 16-bit counter

**Note:** In Capture mode, ETM\_BUF[15:8] and ETM\_BUF[7:0] form a 16-bit counter value, and the counter value should be incremented by one to be the actual counter value in application.

**Explanation 1:**

Due to the internal source goes through the filter, the pulse width of input signal high level and low level must be greater than the width of two SYSTEM Clocks.

**Explanation 2:**

ETM\_IN\_PSCAL[3:2] = 00: Select Capture Input Source 1 cycle, then the Capture effective Resolution is  $1 / 12 \text{ MHz} / 1 = 83.333 \text{ ns}$

ETM\_IN\_PSCAL[3:2] = 11: Select Capture Input Source 16 cycles, then the Capture effective Resolution is  $1 / 12 \text{ MHz} / 16 = 5.208 \text{ ns}$

When select Capture 16 cycles allow the enhanced Timer/Counter to get more significant digits, to reduce capture error.

## 6.12 Serial Peripheral Interface (SPI)

SPI is a synchronous serial interface, allows master to communicate with slave, supports full duplex data transmission, and also supports 3-wire or 4-wire communication.

- SPI supports: Master and Slave mode
- Transmitted serial data can select LSB or MSB being transmitted first
- SPI serial interface transmission speed, frequency range: 6 MHz ~ 23.4375 kHz (Bit rate)

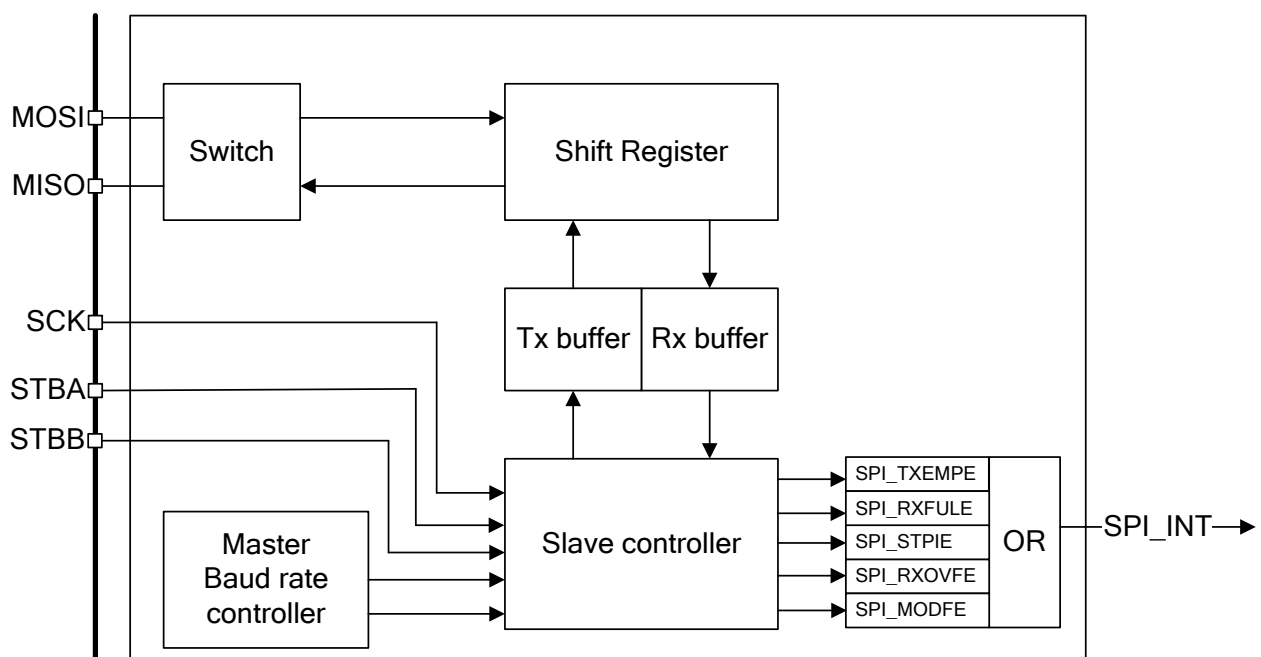

SPI communication uses four pins, as described below.

**MOSI:** In Master mode data output; in slave mode data input.

**MISO:** In Master mode data input; in slave mode data output.

**SCK:** In Master mode clock output; in slave mode clock input for data synchronization.

**STBA, STBB:** In Master mode as output; in slave mode as input.

In Master mode, as the I/O port to enable Slave:

**STBx = 0:** Master enables Slave

**STBx = 1:** Master disables Slave

When use the SPI serial interface, the SPI related pins must be set as output or input status by software, as illustrated below:

4-wire SPI	Master mode	Slave mode	Remarks
MOSI (GPIOB1)	Output	Input	
MISO (GPIOA0/GPIOA1)	Input	Output	Path A: GPIOA0 Path B: GPIOA1
SCK (GPIOA1/GPIOA0)	Output	Input	Path A: GPIOA1 Path B: GPIOA0
STB (GPIOB2)	Output	Input	

**4-wire and 3-wire SPI connection diagram:**

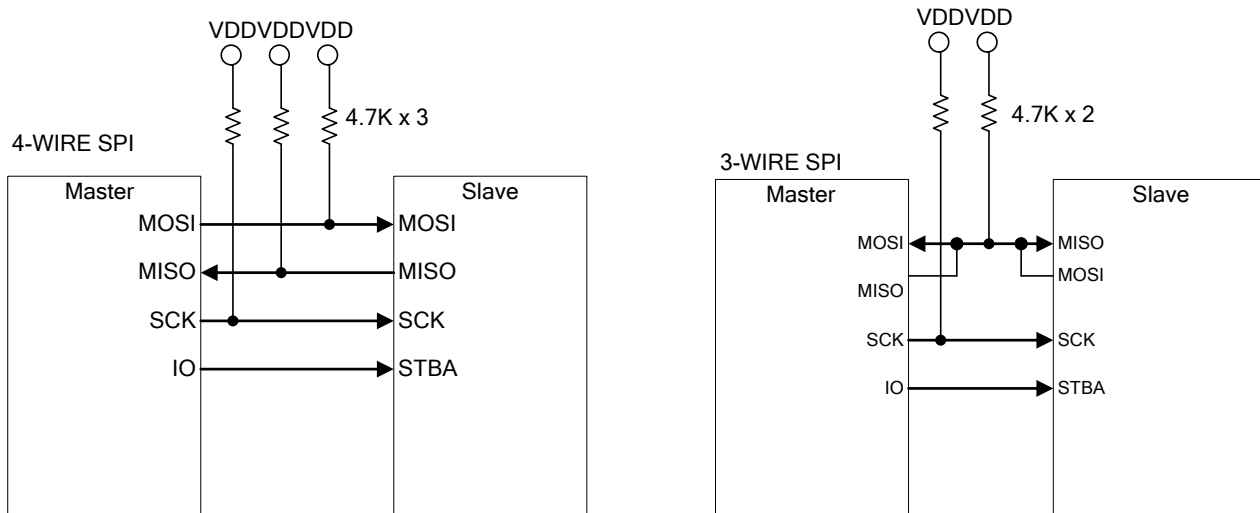

**SPI Control Register 1 SPI\_CTL1 (XFR: 0xC0)**

**Reset Value: 00h**

Bit	Bit 7	Bit 6	Bit 5	Bit 4	Bit 3	Bit 2	Bit 1	Bit 0
Status	R/W	R/W	R/W	R/W	-	R/W	-	-
Name	SPI_EN	SPI_MASTER	SPI_CPOL	SPI_CPHA	Reserved	SPI_LSBFE	Reserved	

Bit Number	Bit Mnemonic	Description
7	SPI_EN	1: Enable SPI module 0: Disable SPI module
6	SPI_MASTER	SPI Master/Slave mode selection 1: SPI as Master mode 0: SPI as Slave mode
5	SPI_CPOL	SPI Clock Polarity bit selection 1: Active-low clock selection 0: Active-high clock selection
4	SPI_CPHA	SPI Clock Phase bit selection 1: Sampling data at even edge of input SPI clock 0: Sampling data at odd edge of input SPI clock

Bit Number	Bit Mnemonic	Description
3	Reserved	-
2	SPI_LSBFE	LSB-First Enable 1: Data is transferred LSB bit first 0: Data is transferred MSB bit first
1-0	Reserved	-

-: unimplemented.

SPI serial interface modes are composed of SPI\_CPOL and SPI\_CPHA, and are classified into four modes as listed below.

SPI_CPOL	SPI_CPHA	Receive data by	Transmit data by	SPI Mode
0	0	Positive-edge trigger	Negative-edge trigger	0
0	1	Negative-edge trigger	Positive-edge trigger	1
1	0	Negative-edge trigger	Negative-edge trigger	2
1	0	Positive-edge trigger	Positive-edge trigger	3

\* Transmit and Receive methods can also refer to “SPI Mode Timing” section that will be described later.

**SPI Control Register 2 SPI\_CTL2 (XFR: 0xC1)**
**Reset Value: 00h**

Bit	Bit 7	Bit 6	Bit 5	Bit 4	Bit 3	Bit 2	Bit 1	Bit 0
Status	R/W	R/W	R/W	R/W	-	-	-	-
Name	SPI_RXONLY	SPI_DFBYP	SPI_DLY[1:0]		Reserved			

Bit Number	Bit Mnemonic	Description
7	SPI_RXONLY	SPI Receive Enable Bit (Master mode use only) 1: Enable SPI Receive mode
6	SPI_DFBYP	Input Digital Filter Bypass Enable Bit (Slave mode use only) 1: Enable Digital Filter
5-4	SPI_DLY[1:0]	Master SPI byte delay control 00: No delay 01: Delay 1 byte 10: Delay 2 bytes 11: Delay 3 bytes
3-0	Reserved	-

-: unimplemented.

**SPI Interrupt Control Register SPI\_INT (XFR: 0xC2)**
**Reset Value: 00h**

Bit	Bit 7	Bit 6	Bit 5	Bit 4	Bit 3	Bit 2	Bit 1	Bit 0
Status	R/W	R/W	R/W	R/W	R/W	-	-	-
Name	SPI_TXEMPE	SPI_RXFULE	SPI_STPIE	SPI_RXOVFE	SPI_MODFE	Reserved		

Bit Number	Bit Mnemonic	Description
7	SPI_TXEMPE	1: Enable SPI Tx data buffer empty interrupt
6	SPI_RXFULE	1: Enable SPI Rx data buffer full interrupt
5	SPI_STPIE	1: Enable SPI Tx sequence finish interrupt
4	SPI_RXOVFE	1: Enable SPI Rx data buffer overflow interrupt
3	SPI_MODFE	1: Enable SPI mode fault Interrupt (Slave mode only)
2-0	Reserved	-

∴ unimplemented.

**SPI Interrupt Clear Register SPI\_CLR (XFR: 0xC3)**
**Reset Value: 00h**

Bit	Bit 7	Bit 6	Bit 5	Bit 4	Bit 3	Bit 2	Bit 1	Bit 0
Status	W	W	W	W	-	-	-	-
Name	CLR_TXEMP	CLR_RXFUL	CLR_STPIF	CLR_RXOVF	Reserved			

Bit Number	Bit Mnemonic	Description
7	CLR_TXEMP	1: Clear SPI Tx data buffer empty interrupt flag
6	CLR_RXFUL	1: Clear SPI Rx data buffer interrupt flag
5	CLR_STPIF	1: Clear SPI sequence full finish interrupt flag
4	CLR_RXOVF	1: Clear SPI Rx data buffer overflow flag
3-0	Reserved	-

∴ unimplemented.

**SPI Flag Register SPI\_FLG (XFR: 0xC4)**
**Reset Value: 00h**

Bit	Bit 7	Bit 6	Bit 5	Bit 4	Bit 3	Bit 2	Bit 1	Bit 0
Status	R	R	R	R	R	R	-	-
Name	SPI_TXEMP	SPI_RXFUL	SPI_STPIF	SPI_RXOVF	SPI_MODF	SPI_BUSY	Reserved	

Bit Number	Bit Mnemonic	Description
7	SPI_TXEMP	SPI transmit data buffer empty flag *1 1: SPI Tx data buffer is empty
6	SPI_RXFUL	SPI receive data buffer full flag 1: SPI Rx data buffer is full
5	SPI_STPIF	SPI Transmit/Receive data finish flag (SS pin go high) 1: SPI Tx/Rx finish
4	SPI_RXOVF	SPI Rx data buffer overflow flag *2 1: SPI receive data buffer overflows
3	SPI_MODF	SPI mode failure status flag (only allowed in Slave mode) *3 1: SPI mode failure
2	SPI_BUSY	SPI Busy status flag *4 1: SPI busy status
1-0	Reserved	-

**-: unimplemented.**

- \*1. The firmware must confirm that only when SPI\_TXEMP = 1, then the next data is allowed to be written into SPI Transmit Buffer Register (SPI\_RXBUF[7:0]).
- \*2. The SPI\_RXOVF flag can be cleared by reading SPI Receive Buffer Register (SPI\_RXBUF[7:0]).
- \*3. The SPI\_MODF flag can be cleared by enabling SPI serial interface module.
- \*4. SPI\_BUSY flag is the status of the WT51F104 internal pin, and it can monitor if SPI is finished or not.

**SPI Bit Rate Setting Register SPI\_BRS[7:0] (XFR: 0xC5)**
**Reset Value: 00h**

Bit	Bit 7	Bit 6	Bit 5	Bit 4	Bit 3	Bit 2	Bit 1	Bit 0
Status	R/W	R/W	R/W	R/W	R/W	R/W	R/W	R/W
Name	SPI_BRS[7:0]							

Bit Number	Bit Mnemonic	Description
7-0	SPI_BRS[7:0]	SPI Bit rate selection (SPI maximum clock = mcu_clk / 2) SPI Bit rate = mcu_clk / (SPI_BRS[7:0]+1) x 2 If mcu_clk = 12 MHz, SPI_BRS[7:0] = 0, SPI Bit Rate is 6 MHz SPI_BRS[7:0] = 1, SPI Bit Rate is 3 MHz ... SPI_BRS[7:0] = 255, SPI Bit Rate is 23.4375 kHz

**SPI Transmit Buffer Register SPI\_TXBUF[7:0] (XFR: 0xC6)**
**Reset Value: FFh**

Bit	Bit 7	Bit 6	Bit 5	Bit 4	Bit 3	Bit 2	Bit 1	Bit 0
Status	R/W	R/W	R/W	R/W	R/W	R/W	R/W	R/W
Name	SPI_TXBUF[7:0]							

Bit Number	Bit Mnemonic	Description
7-0	SPI_TXBUF[7:0]	SPI Transmit Data Buffer

**SPI Receive Buffer Register SPI\_RXBUF[7:0] (XFR: 0xC7)**
**Reset Value: 00h**

Bit	Bit 7	Bit 6	Bit 5	Bit 4	Bit 3	Bit 2	Bit 1	Bit 0
Status	R	R	R	R	R	R	R	R
Name	SPI_RXBUF[7:0]							

Bit Number	Bit Mnemonic	Description
7-0	SPI_RXBUF[7:0]	SPI Receive Data Buffer



**SPI Mode Timing**

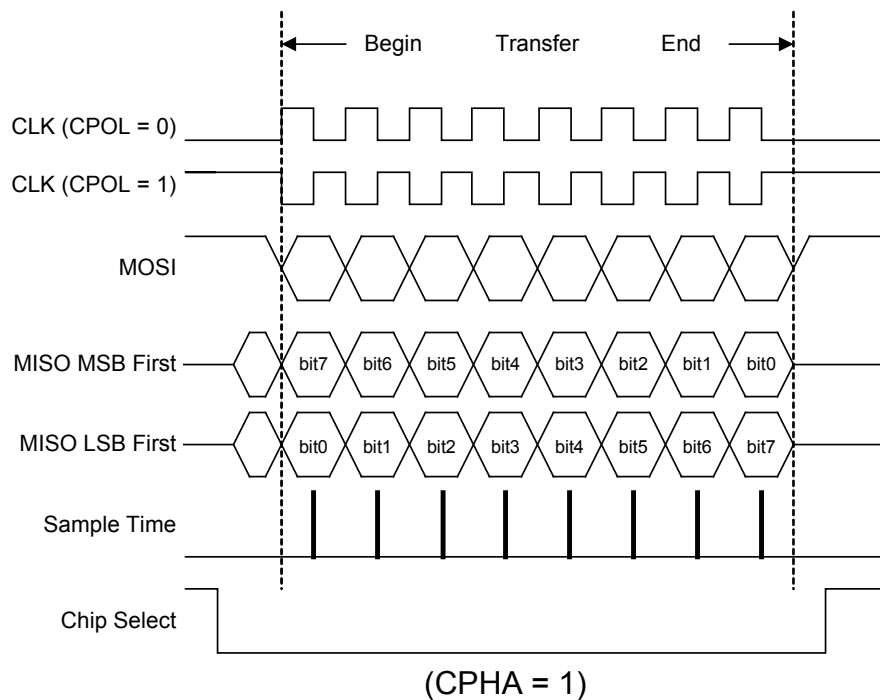
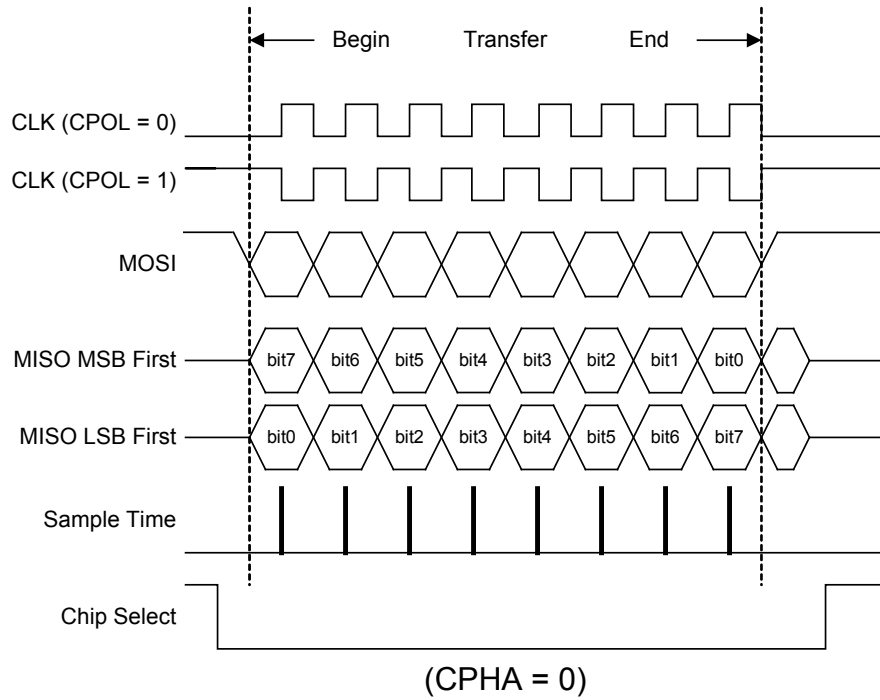

## 6.13 Analog/Digital Converter (ADC)

WT51F104 has a built-in 16-channel 10-bit Analog/Digital Converter, and it also provides four conversion modes (Single, Continuous, Voltage Compare, and Timer Auto mode) and four conversion rate (1 MHz, 500 kHz, 125 kHz, and 31.25 kHz) for selection.

### Single Mode:

Turn on the A/D converter power (XFR: 0xD0 ADC\_CTL, and ADC\_PD = 0), and set the ADC\_SINGLE\_CVT = 1, then the A/D conversion starts. When ADC\_SINGLE\_CVT = 0, the conversion is finished. When conversion is completed, the conversion data will be updated and an interrupt will generate (ADFINSH\_FLG = 1). If ADC convert finish Interrupt is enabled (EN\_ADFINSH\_INT = 1), the ADC interrupt will generate.

### Continuous Mode:

If activate continuous convert control bit XFR: 0xD0 ADC\_CTL and ADC\_CNTNU\_CVT = 1, the system will enter the Continuous Conversion Mode. When conversion is completed, the conversion data will be updated and an interrupt will generate (ADFINSH\_FLG = 1). If ADC convert finish Interrupt is enabled (EN\_ADFINSH\_INT = 1), the ADC interrupt will generate.

### Voltage Compare Mode:

When turn on the A/D converter power (XFR: 0xD0 ADC\_CTL, and ADC Control Register ADC\_PD = 0), and activate the Compare function (EN\_ADC\_CMP = 1), the conversion data of Analog input compare 10-bit setting of XFR: 0xD4 & 0xD5 (ADC\_CMP\_V). When the corresponding digital value of the voltage analog input is greater than (ADC\_BIG = 0) or smaller than (ADC\_BIG = 1) the setting value of ADC\_CMP\_V register, the ADC interrupt will occur. The Voltage Compare function of A/D Converter module worked as a wakeup source. In addition, working together with XFR: 0xD1 ADC\_SEL & ADCMP\_TM to define ADC turn on time for power-saving purpose.

### Timer Auto Mode:

When turn on the ADC\_AUTO\_CVT and work together with the setting of Watch Timer, each Timer event will automatically activate ADC for one-time conversion.

- The conversion time of A/D Converter is **16 us (sampled time 6 us + conversion time 10 us)** based on the conversion rate of 1 MHz
- Reference Voltage sources VREF have three selections: Power Voltage VDD, Built-in voltage reference VBGAP, and External voltage reference VREF

**ADC Control Register ADC\_CTL (XFR: 0xD0)**
**Reset Value: 80h**

Bit	Bit 7	Bit 6	Bit 5	Bit 4	Bit 3	Bit 2	Bit 1	Bit 0
Status	R/W	R/W	R/W	R/W	R/W	R/W	-	R/W
Name	ADC_PD	ADC_SINGLE_CVT	ADC_CNTNU_CVT	ADC_AUTO_CVT	EN_ADC_CMP	EN_ADC_FLT	Reserved	ADC_BIG

Bit Number	Bit Mnemonic	Description
7	ADC_PD	Analog/Digital Converter Power Control 1: Turn off ADC power 0: Turn on ADC power
6	ADC_SINGLE_CVT	ADC start convert bit (single convert mode) 1: ADC start convert 1 => 0: convert finished (hardware will be auto-cleared as "0")
5	ADC_CNTNU_CVT	1: Enable ADC continuous convert (continuous convert mode) 0: Disable ADC continuous convert
4	ADC_AUTO_CVT	1: Enable ADC auto convert one time based on Watch Timer event WTMR_SLT[2:0] (Timer Compare mode)
3	EN_ADC_CMP	1: Enable ADC compare mode (Voltage compare mode)
2	EN_ADC_FLT	1: Enable ADC filter (need to wait for 332nsec) 0: Disable filter function
1	Reserved	-
0	ADC_BIG	ADC data compare flag 1: The data is set when $V_{in} < ADC\_CMP\_V[9:0]$ 0: The data is set when $V_{in} > ADC\_CMP\_V[9:0]$ $V_{in}$ : The channel is selected by EN_AD[3:0]

**Note: Only one converting mode is allowed to enable the ADC at the same time, otherwise ADC may work abnormally.**

**ADC Setting Control Register ADC\_SEL (XFR: 0xD1)**
**Reset Value: 40h**

Bit	Bit 7	Bit 6	Bit 5	Bit 4	Bit 3	Bit 2	Bit 1	Bit 0
Status	R/W	R/W	R/W	-	-	-	R/W	R/W
Name	ADC_CLK_SEL[1:0]		ADCMP_TM	Reserved			ADC_VREF_SEL[1:0]	

Bit Number	Bit Mnemonic	Description
7	ADC_CLK_SEL[1:0]	ADC convert time clock base 00: 1 MHz 01: 500 kHz 10: 125 kHz 11: 31.25 kHz
6		
5	ADCMP_TM	1: Turn on 32 us ADC compare function by Watch Timer at every 32 ms for power-saving purpose. 0: ADC always compare time
4-2	Reserved	-
1-0	ADC_VREF_SEL[1:0]	ADC reference voltage selection 00: From VDD

Bit Number	Bit Mnemonic	Description
		01: From VREF pin 1x: From internal reference voltage BGAP (Bandgap)

∴ unimplemented.

**Note:** Internal reference voltage Bandgap is not calibrated out of the factory, and will be affected by the impact of temperature and supply voltage. The actual voltage value can be read by register. Please refer to the section below and 7.6 & 7.7 Electrical Characteristics.

VBGAP Voltage stored address:

External Memory Address	Description
E04H[1:0]	Record internal Bandgap voltage low bytes = ADC[1:0]
E05H[7:0]	Record internal Bandgap voltage high bytes = ADC[9:2]

VBGAP Voltage formula:  $VBGAP = (5 * ADC[9:0]) / 1024$

Examples:

E04H[1:0] = 0x01

E05H[7:0] = 0x42

$VBGAP = (5 * 0x109) / 1024 = 1.294V$

#### ADC Interrupt Control Register ADC\_INT (XFR: 0xD2)

Reset Value: 00h

Bit	Bit 7	Bit 6	Bit 5	Bit 4	Bit 3	Bit 2	Bit 1	Bit 0
Status	R/W	R/W	-	-	R	R	-	-
Name	EN_ADCMP_INT	EN_ADFINSH_INT	Reserved		ADCMP_FLG	ADFINSH_FLG	Reserved	

Bit Number	Bit Mnemonic	Description
7	EN_ADCMP_INT	1: Enable ADC Compare Interrupt 0: Disable ADC Compare Interrupt
6	EN_ADFINSH_INT	1: Enable ADC Convert Finish Interrupt 0: Disable ADC Convert Finish Interrupt
5-4	Reserved	-
3	ADCMP_FLG	ADC Compare Mode Flag. If the condition selected by ADC_BIG bit in ADC Control Register is met, ADCMP_FLG = 1.
2	ADFINSH_FLG	ADC Finish Interrupt Flag (If the ADC finished convert in single, continuous or timer mode, ADFINSH_FLG = 1)
1-0	Reserved	-

∴ unimplemented.

**Note:** When read AD\_DATA[9:0], the hardware will auto clear the ADCMP\_FLG and ADFINSH\_FLG flag.

**ADC Channel Control Register ADC\_ENCH (XFR: 0xD3)**
**Reset Value: 00h**

Bit	Bit 7	Bit 6	Bit 5	Bit 4	Bit 3	Bit 2	Bit 1	Bit 0
Status	-	-	-	-	R/W	R/W	R/W	R/W
Name	Reserved				EN_AD[3:0]			

Bit Number	Bit Mnemonic	Description
7-4	Reserved	-
3-0	EN_AD[3:0]	Analog/Digital Channel Selection 0000: Select Channel CH0 0001: Select Channel CH1 0010: Select Channel CH2 0011: Select Channel CH3 0100: Select Channel CH4 0101: Select Channel CH5 0110: Select Channel CH6 0111: Select Channel CH7 1000: Select Channel CH8 1001: Select Channel CH9 1010: Select Channel CH10 1011: Select Channel CH11 1100: Select Channel CH12 1101: Select Channel CH13 1110: Select Channel CH14 1111: Select Channel CH15

-: unimplemented.

**ADC Voltage Compare Data High Bytes Register ADC\_CMP\_V[9:2] (XFR: 0xD4)**
**Reset Value: 80h**

Bit	Bit 7	Bit 6	Bit 5	Bit 4	Bit 3	Bit 2	Bit 1	Bit 0
Status	R/W	R/W	R/W	R/W	R/W	R/W	R/W	R/W
Name	ADC_CMP_V[9:2]							

Bit Number	Bit Mnemonic	Description
7-0	ADC_CMP_V[9:2]	ADC_CMP_V[9:2] Compare Voltage Setting, paired with ADC_CMP_V[1:0] to form a 10-bit data

**ADC Voltage Compare Data Low Bytes Register ADC\_CMP\_V[1:0] (XFR: 0xD5)**
**Reset Value: 00h**

Bit	Bit 7	Bit 6	Bit 5	Bit 4	Bit 3	Bit 2	Bit 1	Bit 0
Status	-	-	-	-	-	-	R/W	R/W
Name	Reserved						ADC_CMP_V[1:0]	

Bit Number	Bit Mnemonic	Description
7-2	Reserved	-
1-0	ADC_CMP_V[1:0]	ADC_CMP_V[1:0] Compare Voltage Setting, paired with ADC_CMP_V[9:2] to form a 10-bit data

∴ **unimplemented.**

**ADC Converted Data High Bytes Register AD\_DATA[9:2] (XFR: 0xD6)**

**Reset Value: 00h**

Bit	Bit 7	Bit 6	Bit 5	Bit 4	Bit 3	Bit 2	Bit 1	Bit 0
Status	R	R	R	R	R	R	R	R
Name	AD_DATA[9:2]							

Bit Number	Bit Mnemonic	Description
7-0	AD_DATA[9:2]	AD_DATA[9:2] converted data setting, paired with AD_DATA[1:0] to form a 10-bit data

∴ **unimplemented.**

**ADC Converted Data Low Bytes Register AD\_DATA[1:0] (XFR: 0xD7)**

**Reset Value: 00h**

Bit	Bit 7	Bit 6	Bit 5	Bit 4	Bit 3	Bit 2	Bit 1	Bit 0
Status	-	-	-	-	-	-	R	R
Name	Reserved						AD_DATA[1:0]	

Bit Number	Bit Mnemonic	Description
7-2	Reserved	-
1-0	AD_DATA[1:0]	AD_DATA[1:0] converted data setting, paired with AD_DATA[9:2] to form a 10-bit data

∴ **unimplemented.**

**The setting of Enabling Analog/Digital Converter converted Data procedure:**

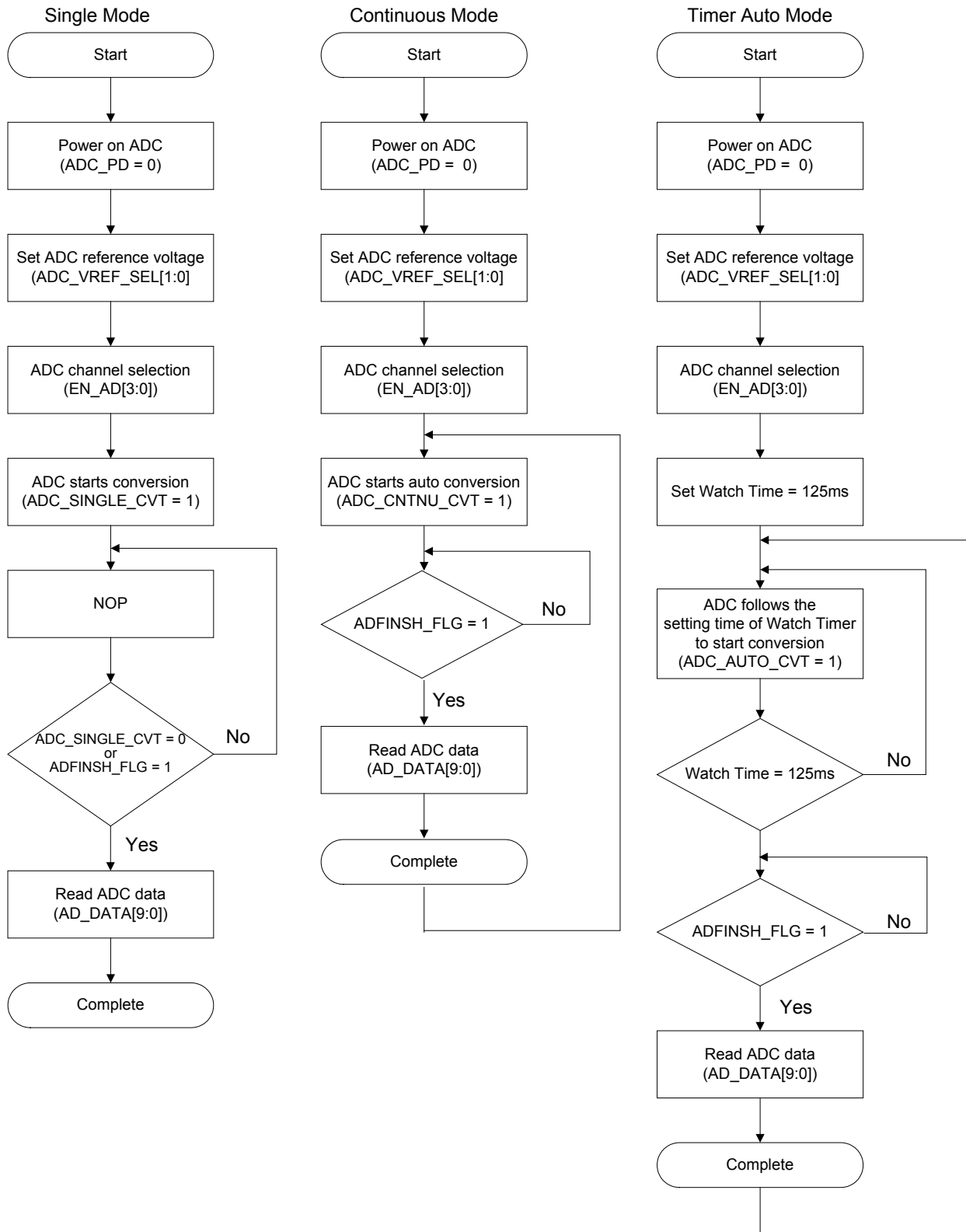

## 6.14 Comparator

WT51F104 built-in one Analog Voltage Comparator with features as listed below.

- Comparator can be enabled or disabled individually.
- The comparator reference voltage is determined by the corresponding Comparator Control Register (ACOMP\_VREF).
- Either the positive-edge or negative-edge of the comparator can generate Interrupt.
- Embedded with comparator capture function (refer to section 6.11)

When the comparator function is enabled (XFR: 0xDA, ACOMP\_PD = 0), the Comparator can compare input (GPIOA0 = CMPP) with the comparator reference voltage (GPIOA1 = CMPN). Then three methods of performing are listed below:

1. Interrupt
2. Event Flag (GPIOA2)
3. Via the Enhanced Timer to perform Gating Timer function

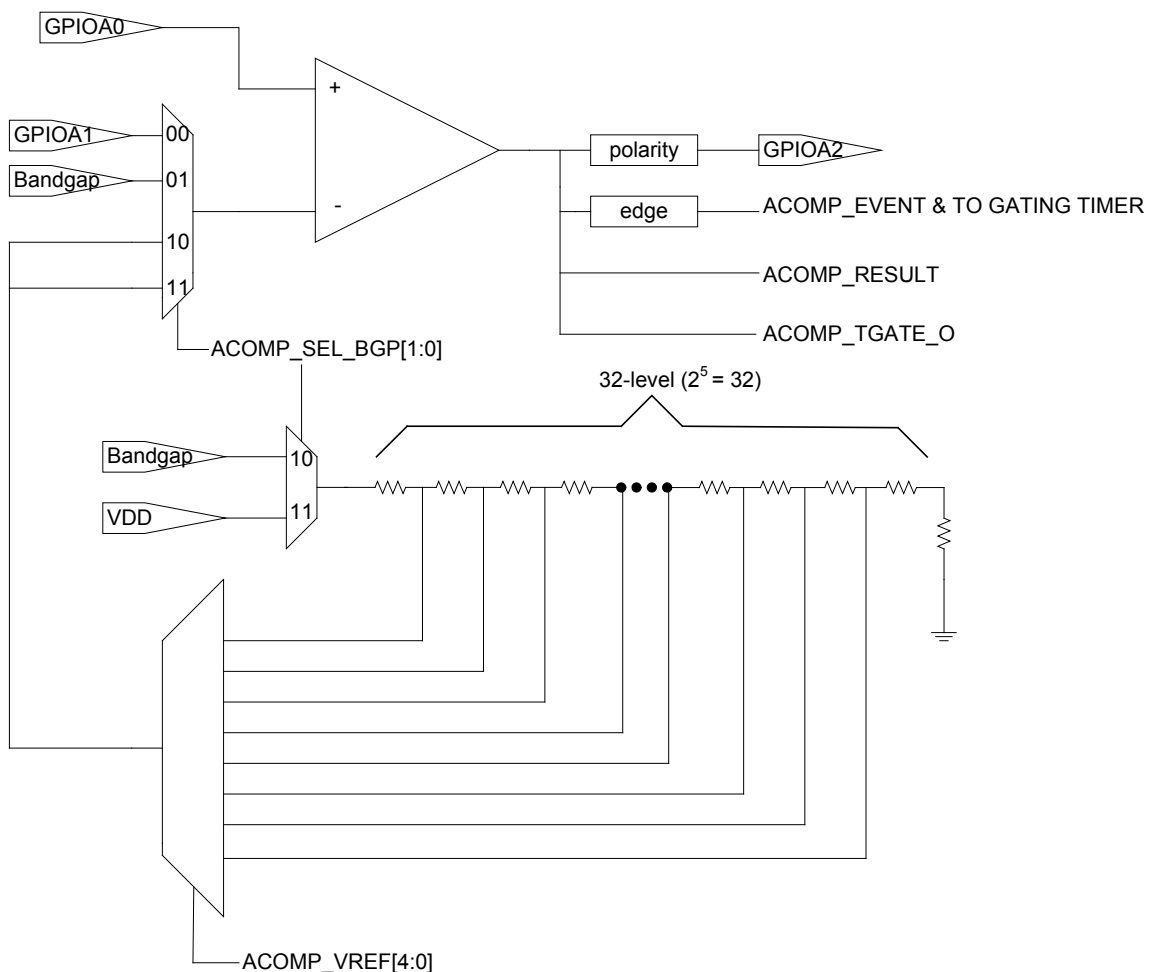



**Comparator Control Register ACOMP\_CTL (XFR: 0xDA)**
**Reset Value: E0h**

Bit	Bit 7	Bit 6	Bit 5	Bit 4	Bit 3	Bit 2	Bit 1	Bit 0
Status	R/W	R/W	R/W	R/W	R/W	-	-	-
Name	ACOMP_PD	ACOMP_SEL_BGP[1:0]	ACOMP_OUT_INV	ACOMP_TGATE	Reserved			

Bit Number	Bit Mnemonic	Description
7	ACOMP_PD	1: Power down Comparator 0: Power on Comparator
6-5	ACOMP_SEL_BGP[1:0]	Comparator CMPN input selection 00: Select GPIOA1 input COMN 01: Select Bandgap input COMN 10: Select nxBGP/32 input COMN 11: Select nxVDD/32 input COMN When select $\frac{n}{32}BGP$ or $\frac{n}{32}VDD$ as input COMN, which can work together with Comparator Reference Voltage Register (0xDC) to provide 32-level reference voltage sources
4	ACOMP_OUT_INV	1: Invert ACOMP_RESULT output 0: Did not invert ACOMP_RESULT output
3	ACOMP_TGATE	1: Comparator output gating signal to enhanced timer/counter to calculate comparator H/L time 0: Comparator didn't output gating signal to enhanced timer/counter
2-0	Reserved	-

**-: unimplemented.**

**Note: Internal reference voltage Bandgap is not calibrated out of the factory, and will be affected by the impact of temperature and supply voltage. Please refer to section 6.13 for the actual voltage value.**

**Comparator Flag Register ACOMP\_FLG (XFR: 0xDB)**
**Reset Value: 00h**

Bit	Bit 7	Bit 6	Bit 5	Bit 4	Bit 3	Bit 2	Bit 1	Bit 0
Status	R	R/W	R	R/W	-	-	-	-
Name	ACOMP_RESULT	ACOMP_EVENT_EDGE	ACOMP_EVENT	CLR_ACOMP_EVENT	Reserved			

Bit Number	Bit Mnemonic	Description
7	ACOMP_RESULT	1: Comparator CMPP voltage > CMPN voltage 0: Comparator CMPP voltage < CMPN voltage (When ACOMP_PD = 1, ACOMP_RESULT = 0)
6	ACOMP_EVENT_EDGE	1: Comparator CMPP voltage < CMPN voltage trigger Interrupt 0: Comparator CMPP voltage > CMPN voltage trigger Interrupt
5	ACOMP_EVENT	Comparator Trigger Flag 1: Comparator trigger occurred 0: Comparator trigger not occurred
4	CLR_ACOMP_EVENT	1: Clear Comparator Trigger Flag 0: No action
3-0	Reserved	-

**-: unimplemented.**

**Comparator Reference Voltage Register ACOMP\_VREF[4:0] (XFR: 0xDC)**
**Reset Value: 00h**

Bit	Bit 7	Bit 6	Bit 5	Bit 4	Bit 3	Bit 2	Bit 1	Bit 0
Status	-	-	-	R/W	R/W	R/W	R/W	R/W
Name	Reserved			ACOMP_VREF[4:0]				

Bit Number	Bit Mnemonic	Description
7-5	Reserved	-
4-0	ACOMP_VREF[4:0]	Comparator Reference Voltage input CMPN, CMPN reference voltage = $ACOMP\_VREF[4:0] * (VDD-VSS)/32 = \frac{n}{32} VDD$ or $ACOMP\_VREF[4:0] * V_{Bandgap}/32 = \frac{n}{32} BGP$

-: unimplemented.

**Comparator Reference Voltage Table:**

ACOMP_VREF[4:0]	CMPN Voltage (VDD = 3.3V; VSS = 0V)	V <sub>Bandgap</sub> = 1.262V
0	0.00	0.00
1	0.10	0.04
2	0.21	0.08
3	0.31	0.12
4	0.41	0.16
5	0.52	0.20
6	0.62	0.24
7	0.72	0.28
8	0.83	0.32
9	0.93	0.35
10	1.03	0.39
11	1.13	0.43
12	1.24	0.47
13	1.34	0.51
14	1.44	0.55
15	1.55	0.59
16	1.65	0.63
17	1.75	0.67
18	1.86	0.71
19	1.96	0.75
20	2.06	0.79
21	2.17	0.83
22	2.27	0.87
23	2.37	0.91

ACOMP_VREF[4:0]	CMPN Voltage (VDD = 3.3V; VSS = 0V)	V <sub>Bandgap</sub> = 1.262V
24	2.48	0.95
25	2.58	0.99
26	2.68	1.03
27	2.78	1.06
28	2.89	1.10
29	2.99	1.14
30	3.09	1.18
31	3.20	1.22

**Example:** The figure below shows comparator input via the enhanced timer to perform Gating Timer to capture low-level or high-level period.

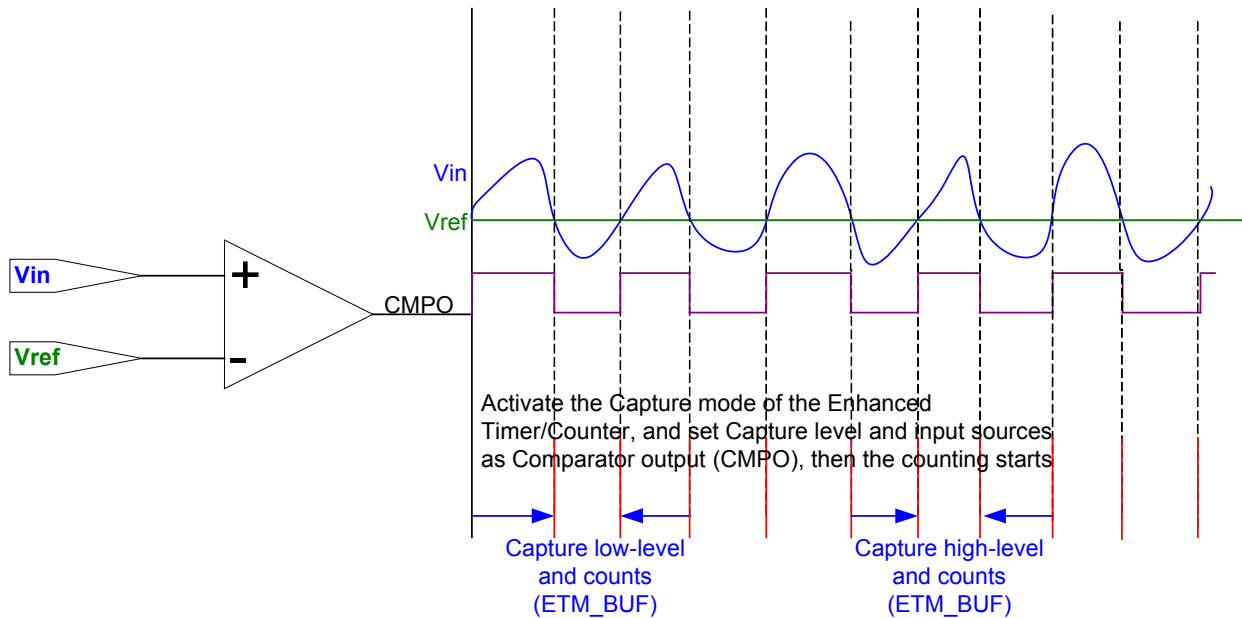

## 6.15 Low Voltage Detection (LVD)

WT51F104 has a built-in Low Voltage Detection circuitry which can detect the supply voltage falls below the minimum specified operating voltage then generates an Interrupt.

- The Enable and Disable function of Low Voltage Detection are controlled by the software
- Low Voltage Detection level provides 8-level of voltage for selection: 2.00V, 2.25V, 2.50V, 2.75V, 3.00V, 3.25V, 3.50V or 3.75V

### Low Voltage Detection Control Register LVD\_CTL (XFR: 0x02)

Reset Value: A6h

Bit	Bit 7	Bit 6	Bit 5	Bit 4	Bit 3	Bit 2	Bit 1	Bit 0
Status	R/W	R	R/W	R/W	R/W	R/W	R/W	R/W
Name	LVD_PD	LVD_CMP	LVD_LVL[2:0]			LVD_RST_PD	LVD_RST_LVL[1:0]	

Bit Number	Bit Mnemonic	Description
7	LVD_PD	1: Power down Low Voltage Detection 0: Turn on Low Voltage Detection
6	LVD_CMP	Low Voltage Detection Compared Result 1: Power Voltage < Setting Low Voltage Detection Voltage Range 0: Power Voltage > Setting Low Voltage Detection Voltage Range
5-3	LVD_LVL[2:0]	Low Voltage Detection Range: 000: 2.00V 001: 2.25V 010: 2.50V 011: 2.75V 100: 3.00V 101: 3.25V 110: 3.50V 111: 3.75V

Note: The voltage range of Low Voltage Detection has great tolerance. Please refer to section 7.8 Electrical Characteristics for more details.

## 6.16 Low Voltage Detection Reset (LVDR)

WT51F104 has a built-in Low Voltage Detection circuitry which can detect the supply voltage falls below the minimum specified operating voltage then generates a Reset.

- The Enable and Disable function of Low Voltage Detection Reset are controlled by the software
- Low Voltage Detection level provides 4-level of voltage for selection: 2.00V, 2.50V, 3.00V or 3.50V

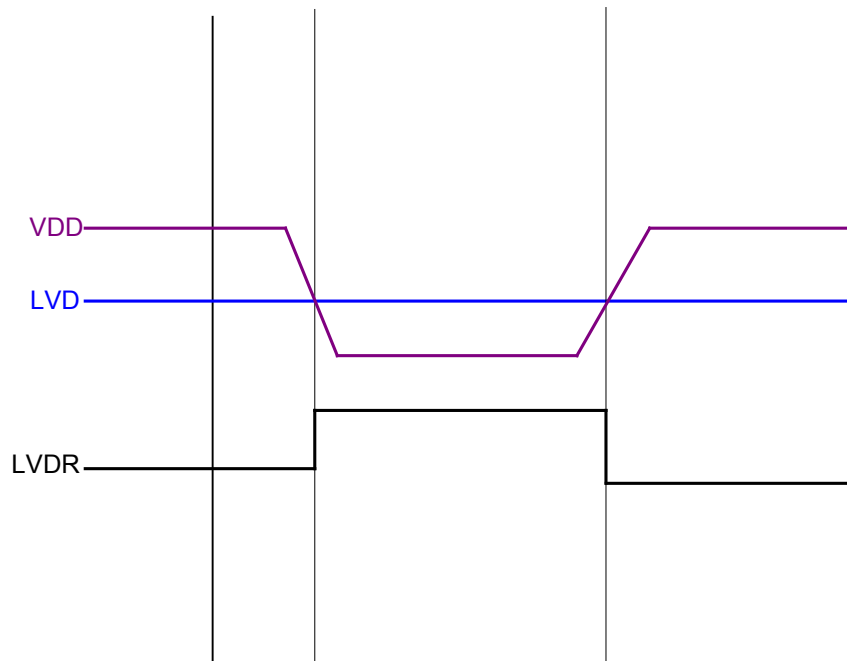

**Low Voltage Detection Control Register LVD\_CTL (XFR: 0x02)**

**Reset Value: A6h**

Bit	Bit 7	Bit 6	Bit 5	Bit 4	Bit 3	Bit 2	Bit 1	Bit 0
Status	R/W	R	R/W	R/W	R/W	<b>R/W</b>	<b>R/W</b>	<b>R/W</b>
Name	LVD_PD	LVD_CMP	LVD_LVL[2:0]			<b>LVD_RST_PD</b>	<b>LVD_RST_LVL[1:0]</b>	

Bit Number	Bit Mnemonic	Description
2	LVD_RST_PD	1: Turn off Low Voltage Detection Reset power 0: Turn on Low Voltage Detection Reset power
1-0	LVD_RST_LVL[1:0]	Low Voltage Detection Reset Range: 00: 2.00V 01: 2.50V 10: 3.00V 11: 3.50V

Note: The voltage range of Low Voltage Detection Reset has great tolerance. Please refer to section 7.8 Electrical Characteristics for more details.

**Reset Flag Register RESET\_FLG (XFR: 0x03)**
**Reset Value: 01h**

Bit	Bit 7	Bit 6	Bit 5	Bit 4	Bit 3	Bit 2	Bit 1	Bit 0
Status	W	R	R	R	R	R	R	R
Name	CLR_RST_FLG	PC_OVL_RST_FLG	ISP_RST_FLG	WDT_RST_FLG	NRST_FLG	LVD_RST_FLG	LVR_RST_FLG	POR_RST_FLG

Bit Number	Bit Mnemonic	Description
7	CLR_RST_FLG	1: Clear all Reset Flag
6	PC_OVL_RST_FLG	1: Reset source is from program counter overflow
5	ISP_RST_FLG	1: Reset source is from ISP
4	WDT_RST_FLG	1: Reset source is from Watchdog
3	NRST_FLG	1: Reset source is from External Reset pin
2	LVD_RST_FLG	1: Reset source is from Low Voltage Detection Reset
1	LVR_RST_FLG	1: Reset source is from Low Voltage Reset
0	POR_RST_FLG	1: Reset source is from External Power Reset

**Note:** For more details, refer to section 5.7 “Reset”.

## 6.17 Emulated E<sup>2</sup>PROM

The WT51F104 can use Flash PROM space to emulate E<sup>2</sup>PROM, and the storage address ranges from: 0x0C00 ~ 0x0EFF (768 bytes).

### E<sup>2</sup>PROM Enable Register 1 EER\_EN1[3:0] (XFR: 0xE0)

**Reset Value: 00h**

Bit	Bit 7	Bit 6	Bit 5	Bit 4	Bit 3	Bit 2	Bit 1	Bit 0
Status	-	-	-	-	W	W	W	W
Name	Reserved				EER_EN1[3:0]			

Bit Number	Bit Mnemonic	Description
7-4	Reserved	-
3-0	EER_EN1[3:0]	When EER_EN1[3:0] = '1010' and EER_EN2[3:0] = '0101', the E <sup>2</sup> PROM function is enabled.

-: unimplemented.

### E<sup>2</sup>PROM Enable Register 2 EER\_EN2[3:0] (XFR: 0xE1)

**Reset Value: 00h**

Bit	Bit 7	Bit 6	Bit 5	Bit 4	Bit 3	Bit 2	Bit 1	Bit 0
Status	-	-	-	-	W	W	W	W
Name	Reserved				EER_EN2[3:0]			

Bit Number	Bit Mnemonic	Description
7-4	Reserved	-
3-0	EER_EN2[3:0]	When EER_EN2[3:0] = '0101' and EER_EN1[3:0] = '1010', the E <sup>2</sup> PROM function is enabled.

-: unimplemented.

### E<sup>2</sup>PROM Address Low Bytes Register EER\_ADDR[7:0] (XFR: 0xE2)

**Reset Value: FFh**

Bit	Bit 7	Bit 6	Bit 5	Bit 4	Bit 3	Bit 2	Bit 1	Bit 0
Status	R/W	R/W	R/W	R/W	R/W	R/W	R/W	R/W
Name	EER_ADDR[7:0]							

Bit Number	Bit Mnemonic	Description
7-0	EER_ADDR[7:0]	EER_ADDR[7:0] address setting, paired with EER_ADDR[11:8] to form a 12-bit address

**E<sup>2</sup>PROM Address High Bytes Register EER\_ADDR[11:8] (XFR: 0xE3)**
**Reset Value: 0Fh**

Bit	Bit 7	Bit 6	Bit 5	Bit 4	Bit 3	Bit 2	Bit 1	Bit 0
Status	-	-	-	-	R/W	R/W	R/W	R/W
Name	Reserved				EER_ADDR[11:8]			

Bit Number	Bit Mnemonic	Description
7-4	Reserved	-
3-0	EER_ADDR[11:8]	EER_ADDR[11:8] address setting, paired with EER_ADDR[7:0] to form a 12-bit address

**E<sup>2</sup>PROM Control Register EER\_TCTL[3:0] (XFR: 0xE4)**
**Reset Value: 08h**

Bit	Bit 7	Bit 6	Bit 5	Bit 4	Bit 3	Bit 2	Bit 1	Bit 0
Status	-	W	W	W	W	W	W	W
Name	Reserved	ERR_IFREN	EER_ERASE	EER_PROG	EER_TCTL[3:0]			

Bit Number	Bit Mnemonic	Description
7	Reserved	-
6	ERR_IFREN	Must be set as "0"
5	EER_ERASE	1: E <sup>2</sup> PROM proceeds ERASE (256 Bytes) /page 0: Did not proceed ERASE
4	EER_PROG	1: E <sup>2</sup> PROM proceeds PROGRAM (1 Byte) 0: Did not proceed PROGRAM
3-0	EER_TCTL[3:0]	E <sup>2</sup> PROM ERASE/PROGRAM time setting (see Note)

**E<sup>2</sup>PROM Data Register EER\_DATA[7:0] (XFR: 0xE8)**
**Reset Value: 00h**

Bit	Bit 7	Bit 6	Bit 5	Bit 4	Bit 3	Bit 2	Bit 1	Bit 0
Status	W	W	W	W	W	W	W	W
Name	EER_DATA[7:0]							

Bit Number	Bit Mnemonic	Description
7-0	EER_DATA[7:0]	E <sup>2</sup> PROM Data Register

**Notes:**

- MCU clock will be turned off in programming or erasing E<sup>2</sup>PROM, and thus all functions of 8052 are halt state. Please refer to 3.1 System Clock Tree for more details.
- Recommended:  
Only if MCU\_CLK = 12 MHz, programming or erasing E<sup>2</sup>PROM is allowed, and EER\_TCTL[3:0] can be set as "1000". Thus, the programming time of 1 Byte = 28u sec ~ 32u sec. The erasing time of 1 Bank (256 Bytes) = 28m sec ~ 32m sec.
- LVR must be disabled prior to programming or erasing E<sup>2</sup>PROM; LVR can be enabled only after programming or erasing E<sup>2</sup>PROM is finished. Please refer to E<sup>2</sup>PROM Enable Flow Chart for more details.



**E<sup>2</sup>PROM Clear Range and Address Setting (Cleared data 0xFF)**

Flash address	EER_ADDR[11:8]	EER_ADDR[7:0]	Erase Range	Remark
0x0C00	1100	0000 0000	0x0C00 ~ 0x0CFF	
0x0D00	1101	0000 0000	0x0D00 ~ 0x0DFF	
0x0E00	1110	0000 0000	0x0E00 ~ 0x0EFF	

**E<sup>2</sup>PROM Enable Flow chart:**

**Programming function:**

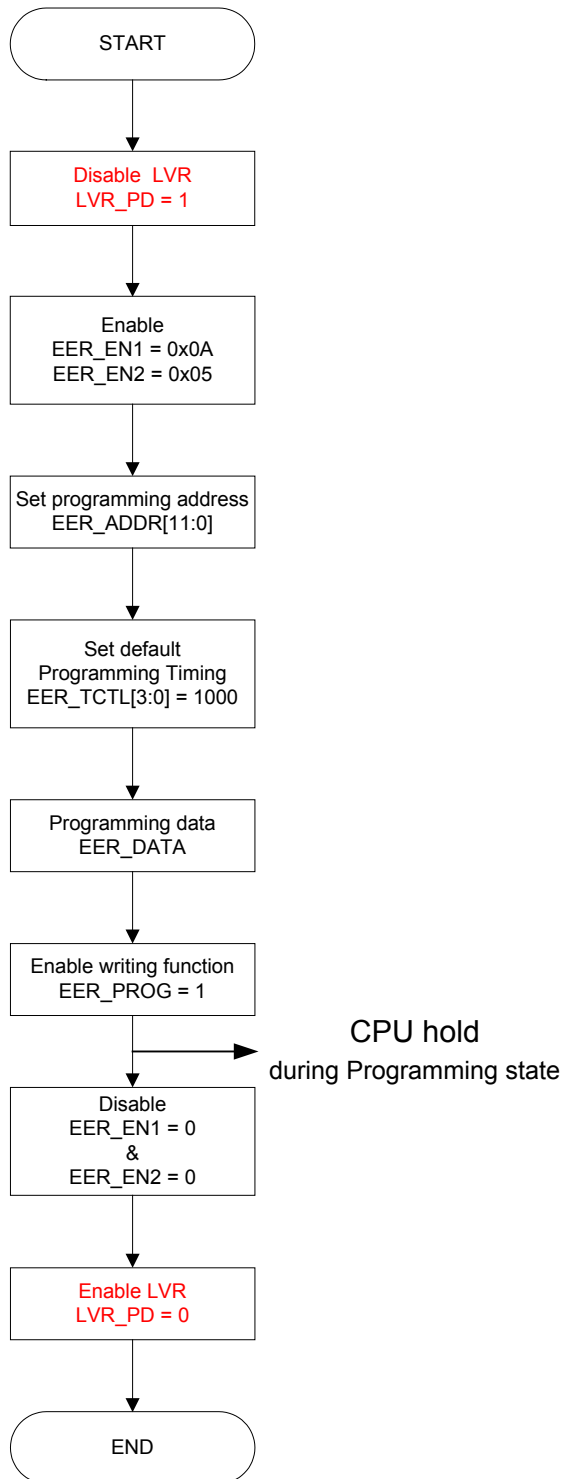

**Erasing function:**

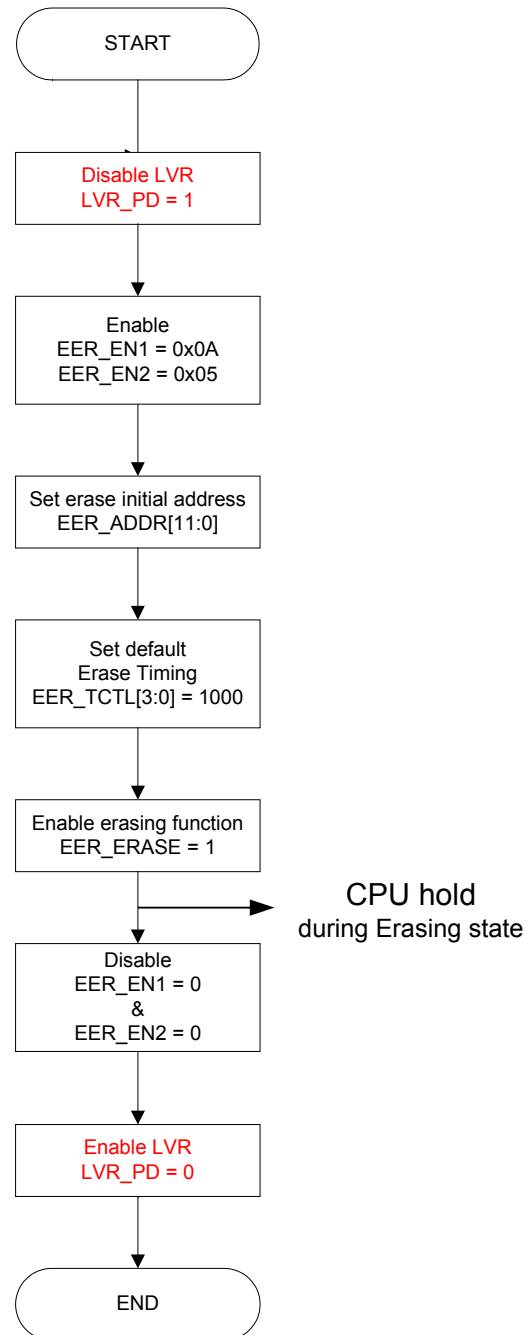

## 6.18 Code Option

Code Block located in the last eight bytes of Flash ROM for storing customer ID and IC configuration with address listed as the following table.

If this function is not enabled, please reserve the space of these eight bytes, and fill it with 0xFF.

If the function is enabled, WT51F104 will auto reload the code option at each reset. Please refer to the Sequency Diagram as listed below

Address	Bit Number	Description
0FF8H	7-0	= AFH, enable Code Option. If the higher 4 bits of this byte is "1010", Code Option is enabled. = FFH, disable Code Option Default value 0xFF
0FF9H	7-0	Customer ID 1, mapping to XFR: CSM_ID1 0x0D[7:0] Default value 0xFF: code can be assigned by SWUT ISP software programming
0FFAH	7-0	Customer ID 2, mapping to XFR: CSM_ID2 0x0E[7:0] Default value 0xFF: code can be assigned by SWUT ISP software programming
0FFBH	7-0	Customer ID 3, mapping to XFR: CSM_ID3 0x0F[7:0] Default value 0xFF: code can be assigned by SWUT ISP software programming
0FFCH	7-0	Flash memory content protection: <b>it is an individual setting, and will not be turned off even if Code Option is disabled.</b> = 00H flash memory cannot be written into = 10H flash memory cannot be read Default value 0xFF: Flash can read/write (by code encryption to achieve the same protection)
<b>General Purpose I/O Complex Function Options Setting:</b>		
0FFDH	7-5	Reserved
	4	Mapping to XFR: GPA3_FUN_SLT = 26H[5:4] 1: Reset pin (NRST) 0: GPIO (default)
	3	Mapping to XFR: GPA4_FUN_SLT = 25H[1:0] 1: Main External Crystal Oscillator pin (main crystal) 0: GPIO (default)
	2	Mapping to XFR: LVD_RST_PD = 02H[2] 1: Disable Low Voltage Reset (default) 0: Enable Low Voltage Reset
	1-0	Mapping to XFR: LVD_RST_LVL = 02H[1:0] , low voltage detection and reset level setting 00: 2.00V 01: 2.50V 10: 3.00V (default) 11: 3.50V
<b>Oscillator Initialization and Driving Ability Options Setting:</b>		
0FFEH	7-5	Reserved
	4-3	Mapping to XFR: SOURCE_CLK_SLT[1:0] 0x05H[3:2]; initialization value of main oscillator 00: SOURCE clock = internal 12 MHz RC oscillator (default) 01: SOURCE clock = external 32 kHz ~ 24 MHz crystal oscillator 1X: SOURCE clock = internal 32 kHz RC oscillator

Address	Bit Number	Description
	2-1	Mapping to XFR: CRY_12M_DR[1:0] 0x08H[2:1]; oscillator driving ability selection 00: Select < 100 kHz crystal oscillator 01: Select 100 kHz ~ 1 MHz crystal oscillator 10: Select 1 MHz ~ 12 MHz crystal oscillator (default) 11: Select 12 MHz ~ 24 MHz crystal oscillator
	0	Mapping to XFR: BLDO_PD 0x08H[0]; internal voltage regulator (main LDO) 1: Turn off 0: Turn on (default)
<b>All Oscillator Power Switch Options Setting:</b>		
0FFFH	7-5	Reserved
	4	Mapping to XFR: IRC_12M_PD1 0x07H[4] 1: Turn off partial power of internal 12 MHz RC oscillator 0: Turn on partial power of internal 12 MHz RC oscillator (default)
	3	Mapping to XFR: IRC_12M_PD2 0x07H[3] 1: Turn off all power of internal 12 MHz RC oscillator 0: Turn on all power of internal 12 MHz RC oscillator (default)
	2	Reserved
	1	Mapping to XFR: CRY_12M_PD 0x 07H[1] 1: Turn off external 32 kHz ~ 24 MHz crystal oscillator (default) 0: Turn on external 32 kHz ~ 24 MHz crystal oscillator
	0	Reserved

Note: Code option setting would be overwritten by program setting, it is recommended to use the program to set the code option. Please refer to the next page for code option setting examples and code example program.

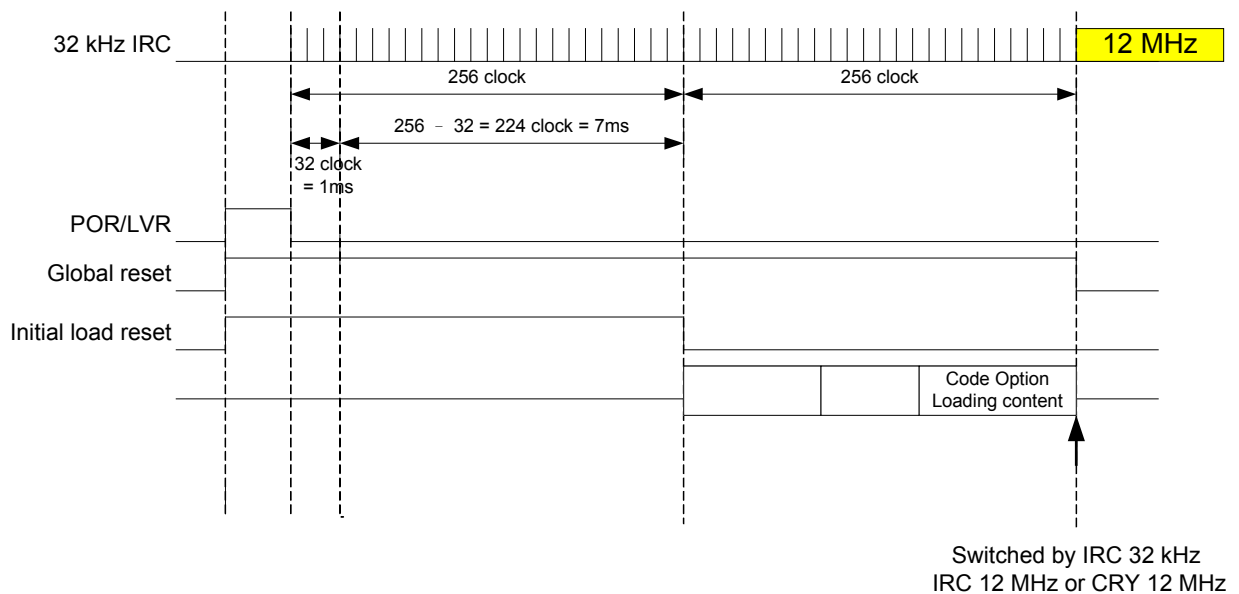

**WT51F104 Code Option example:**

```

;-----
; This Code: CodeOption104.A51 is for WT51F104 Code Option Setting
;-----
#define OPTION_ON          1
#define OPTION_OFF        0
;;Default Code Option OFF
#define WT51F104_CODE_OPTION OPTION_OFF

    #if(WT51F104_CODE_OPTION==OPTION_ON)
    ;;Load Code option switch
    CSEG    AT 0x0FF8
    DB      10101111B    ;;0xAF: load code option

    ;;Customer ID 1
    CSEG    AT 0x0FF9
    DB      11111111B
    ;;Customer ID 2
    CSEG    AT 0x0FFA
    DB      11111111B
    ;;Customer ID 3
    CSEG    AT 0x0FFB
    DB      11111111B

    ;;Flash Protect Read/Write
    CSEG    AT 0x0FFC
    ;;Flash memory content protection:
    ;;default 0xFF select no protection MCU can read/write
    ;;bit7-0 = 10H flash memory cannot be read
    ;;bit7-0 = 00H flash memory cannot be written into
    DB      11111111B

    ;;Crystal GPIO setting
    CSEG    AT 0x0FFD
    ;;bit7 NC default 0
    ;;bit6-5 Mapping to XFR: GPA4_FUN_SLT = 25H[1:0]
    ;;default 00 GPIOA4 set GPIO function
    ;;00: GPIO
    ;;10: Main crystal
    ;;bit4-3 Mapping to XFR: GPA3_FUN_SLT = 26H[5:4]
    ;;default 00 GPIOA3 set GPIO function
    ;;00: GPIO
    ;;10: NRST
    ;;bit2 Mapping to XFR: LVD_RST_PD 0x02H[2]
    ;;default 1 select disable
    ;;1: disable low voltage reset
    ;;0: enable low voltage reset
    ;;bit1-0 Mapping to XFR: LVD_RST_LVL 0x02H[1:0], low voltage detection and reset level setting
    ;;default 10 select 3.00V
    ;;00: 2.00V
    ;;01: 2.50V
    ;;10: 3.00V
    ;;11: 3.50V
    DB      00000110B

    ;;Source Clock and Crystal drive setting
    CSEG    AT 0x0FFE
    ;;bit7 NC default 0

```

```

;;bit6 NC default 0
;;bit5 NC default 0
;;bit4-3 Mapping to XFR: SOURCE_CLK_SLT[1:0] 0x05H[3:2]; initialization value of main oscillator
;;default 00
;;00: SOURCE clock = internal 12 MHz RC oscillator
;;01: SOURCE clock = external 32 kHz ~ 24 MHz crystal oscillator
;;1X: SOURCE clock = internal 32 kHz RC oscillator
;;bit2-1 Mapping to XFR: CRY_12M_DR[1:0] 0x08H[2:1]; oscillator driving ability selection
;;default 10
;;00: select < 100 kHz crystal oscillator
;;01: select 100 kHz ~ 1 MHz crystal oscillator
;;10: select 1 MHz ~ 12 MHz crystal oscillator
;;11: select 12 MHz ~ 24 MHz crystal oscillator
;;bit0 Mapping to XFR: BLDO_PD 0x08H[0]; internal voltage regulator (main LDO)
;;default turn on
;;1: turn off
;;0: turn on
DB 00000100B

;;Crystal Power setting
CSEG AT 0x0FFF
;;bit7 NC default 0
;;bit6 NC default 0
;;bit5 NC default 0
;;bit4 Mapping to XFR: IRC_12M_PD1 0x07H[4] default turn on
;;1: turn off partial power of internal 12 MHz RC oscillator
;;0: turn on partial power of internal 12 MHz RC oscillator
;;bit3 Mapping to XFR: IRC_12M_PD2 0x07H[3] default turn on
;;1: turn off all power of internal 12 MHz RC oscillator
;;0: turn on all power of internal 12 MHz RC oscillator
;;bit2 Mapping to XFR: IRC_32K_PD 0x07H[2] default turn on
;;1: turn off the power of internal 32 kHz RC oscillator
;;0: turn of the power of internal 32 kHz RC oscillator
;;bit1 Mapping to XFR: CRY_12M_PD 0x07H[1] default turn off
;;1: Turn off external 32 kHz ~ 24 MHz crystal oscillator
;;0: Turn on external 32 kHz ~ 24 MHz crystal oscillator
;;bit0 NC default 0
DB 00000010B
#else
CSEG AT 0x0FF8
DB 11111111B
CSEG AT 0x0FF9
DB 11111111B
CSEG AT 0x0FFA
DB 11111111B
CSEG AT 0x0FFB
DB 11111111B
CSEG AT 0x0FFC
DB 11111111B
CSEG AT 0x0FFD
DB 11111111B
CSEG AT 0x0FFE
DB 11111111B
CSEG AT 0x0FFF
DB 11111111B
#endif

```

Customer ID 1~ 3 mapped to the Customer Code Registers, please refer to the following customer code registers.

**Customer Code Register 1 CSTM\_ID1 (XFR: 0x0D) Reset Value: FFh**

Bit	Bit 7	Bit 6	Bit 5	Bit 4	Bit 3	Bit 2	Bit 1	Bit 0
Status	R	R	R	R	R	R	R	R
Name	CSTM_ID1							

Bit Number	Bit Mnemonic	Description
7-0	CSTM_ID1	Customer code, paired with CSTM_ID2 and CSTM_ID3, 3 bytes in total.

**Customer Code Register 2 CSTM\_ID2 (XFR: 0x0E) Reset Value: FFh**

Bit	Bit 7	Bit 6	Bit 5	Bit 4	Bit 3	Bit 2	Bit 1	Bit 0
Status	R	R	R	R	R	R	R	R
Name	CSTM_ID2							

Bit Number	Bit Mnemonic	Description
7-0	CSTM_ID2	Customer code, paired with CSTM_ID3 and CSTM_ID1, 3 bytes in total.

**Customer Code Register 3 CSTM\_ID3 (XFR: 0x0F) Reset Value: FFh**

Bit	Bit 7	Bit 6	Bit 5	Bit 4	Bit 3	Bit 2	Bit 1	Bit 0
Status	R	R	R	R	R	R	R	R
Name	CSTM_ID3							

Bit Number	Bit Mnemonic	Description
7-0	CSTM_ID3	Customer code, paired with CSTM_ID1 and CSTM_ID2, 3 bytes in total.

**Note:** WT51F104 provides three bytes (24 bits) of code option, which can be set by customer to read data from program storage after reset.

The following registers is described in the previous section, and now is set for the Code Option registers mapped in the General-purpose I/O Complex Function options, including the Option settings of the crystal oscillator pins, Reset, and Low Voltage Detection Reset.

0x25, 0x26, 0x02 registers again described as below.

**General-purpose I/O Port A Complex Function Setting Register1 GPIOA\_FUN1 (XFR: 0x25) Reset Value: 00h**

Bit	Bit 7	Bit 6	Bit 5	Bit 4	Bit 3	Bit 2	Bit 1	Bit 0
Status	-	R/W	R/W	R/W	-	R/W	R/W	R/W
Name	Reserved	GPA5_FUN_SLT[2:0]			Reserved	GPA4_FUN_SLT[2:0]		

Bit Number	Bit Mnemonic	Description
7	Reserved	-
6-4	GPA5_FUN_SLT[2:0]	Set GPIOA5DH complex function 000: GPIO/IRQ15 (default) 001: ADC15 input 011: PWM1 output of Path B 010: T1 input 101: P00 output/input (mapping to 8052 P0.0) <b>Note: If GPIOA4DH = OCSO, GPIOA5DH must be set as GPIO.</b>
3	Reserved	-
2-0	GPA4_FUN_SLT[2:0]	Set GPIOA4DH complex function 000: GPIO/IRQ14/ETMIA (default) 001: ADC14 input 010: OSCO (If GPIOA4DH = OCSO, GPIOA5DH must be set as GPIO) 011: PWM0 output of Path B 101: P01 output/input (mapping to 8052 P0.1)

-: unimplemented.

**General-purpose I/O Port A Complex Function Setting Register2 GPIOA\_FUN2 (XFR: 0x26)      Reset Value: 00h**

Bit	Bit 7	Bit 6	Bit 5	Bit 4	Bit 3	Bit 2	Bit 1	Bit 0
Status	-	R/W	R/W	R/W	-	R/W	R/W	R/W
Name	Reserved	GPA3_FUN_SLT[2:0]			Reserved	GPA2_FUN_SLT[2:0]		

Bit Number	Bit Mnemonic	Description
7	Reserved	-
6-4	GPA3_FUN_SLT[2:0]	Set GPIA3D complex function 000: GPIO/IRQ13/ETMIB (default) 001: ADC13 input 010: Reset pin (NRST) input
3	Reserved	-
2-0	GPA2_FUN_SLT[2:0]	Set GPIOA2DH complex function 000: GPIO/IRQ2 (default) 001: ADC2 input 010: CMPO, Comparator output 011: PWM1 output of Path C 101: T0 input

-: unimplemented.



**Low Voltage Detection Control Register LVD\_CTL (XFR: 0x02)**
**Reset Value: A6h**

Bit	Bit 7	Bit 6	Bit 5	Bit 4	Bit 3	Bit 2	Bit 1	Bit 0
Status	R/W	R	R/W	R/W	R/W	R/W	R/W	R/W
Name	LVD_PD	LVD_CMP	LVD_LVL[2:0]			LVD_RST_PD	LVD_RST_LVL[1:0]	

Bit Number	Bit Mnemonic	Description
7	LVD_PD	1: Power down Low Voltage Detection 0: Turn on Low Voltage Detection
6	LVD_CMP	Low Voltage Detection Compared Result 1: Power Voltage < Setting Low Voltage Detection Voltage Range 0: Power Voltage > Setting Low Voltage Detection Voltage Range
5-3	LVD_LVL[2:0]	Low Voltage Detection Range: 000: 2.00V 001: 2.25V 010: 2.50V 011: 2.75V 100: 3.00V 101: 3.25V 110: 3.50V 111: 3.75V

The following registers is described in the previous section, and now is set for the Code Option registers mapped in the Initialized Oscillator & Driving Ability options, including the Option settings of the crystal oscillator source and Driving ability.

0x05, 0x08 Register again described as below.

**System Clock Source Control Register SOURCE\_CLK\_SLT (XFR: 0x05)**
**Reset Value: A0h**

Bit	Bit 7	Bit 6	Bit 5	Bit 4	Bit 3	Bit 2	Bit 1	Bit 0
Status	-	-	-	-	R/W	R/W	R/W	R/W
Name	Reserved				SOURCE_CLK_SLT[1:0]		MCU_CLK_SLT[1:0]	

Bit Number	Bit Mnemonic	Description
7-4	Reserved	Must be equal to "1010", otherwise bit [3:0] cannot be written into.
3-2	SOURCE_CLK_SLT[1:0]	Select SOURCE clock sources 00: Internal 12 MHz RC oscillator (default) 01: External DC ~ 24 MHz crystal oscillator 10: Internal 32 kHz RC oscillator Default value can be selected by section 6.18 Code Option Select
1-0	MCU_CLK_SLT[1:0]	MCU clock setting 00: MCU clock = SOURCE clock (default) 01: MCU clock = SOURCE clock /2 10: MCU clock = SOURCE clock /4 11: MCU clock = SOURCE clock /12

:- unimplemented.

**Notes:**

1. Due to external crystal oscillator pin supports both 12 MHz & 32.768 kHz crystal oscillator, do not turn off BLDO\_PD when SOURCE clock selects external 32.768 kHz crystal oscillator. Otherwise, SOURCE clock will stop working and fail to programming. Please select SOURCE clock as internal 32 kHz RC oscillator to work together with WatchTimer selecting external 32.768 kHz crystal oscillator.
2. When SOURCE clock selects internal 32 kHz RC oscillator and the system clock source of the Watch Timer selects External 32.768 kHz crystal oscillator, Interrupt sources cannot be captured in time due to Internal 32 kHz RC oscillator with huge tolerance and the execute speed is slower than the Interrupt generated by Watch Timer. In this mode, it requires having the External Clock Source Prescaler Control Register 1 and External Clock Source Prescaler Control Register 2 setting divided by 2, and the Watch Timer clock source divided by 2 equals to 16.384 kHz. In the meantime, the time period selected by the Watch Timer will be extended twice to capture completely without missing.

**Setting External Clock Source/ 2 procedures:**

1. Setting Prescaler Data:  $CRY\_DIV[9:0] = 1$ , and  $32.768 \text{ kHz} / (CRY\_DIV[9:0] + 1) = 32.768 \text{ kHz} / 2 = 16.384 \text{ kHz}$
2. Enable external crystal oscillator clock source prescaler:  $EN\_CRY\_DIV = 1$

**Oscillator Driver Control Register CRY\_12M\_DR[1:0] (XFR: 0x08)**
**Reset Value: 54h**

Bit	Bit 7	Bit 6	Bit 5	Bit 4	Bit 3	Bit 2	Bit 1	Bit 0
Status	-	-	-	-	-	R/W	R/W	R/W
Name	Reserved				Reserved	CRY_12M_DR[1:0]	BLDO_PD	

Bit Number	Bit Mnemonic	Description
7-4	Reserved	Must be equal to "0101", otherwise, Bit[3:0] cannot be written into
3	Reserved	-
2-1	CRY_12M_DR[1:0]	External oscillator driving ability setting 00: Crystal oscillator with frequency < 100 kHz 01: Crystal oscillator with frequency of 100 kHz ~ 1 MHz 10: Crystal oscillator with frequency of 1 MHz ~ 12 MHz (default) 11: Crystal oscillator with frequency of 12 MHz ~ 24 MHz Default value can be selected by section 6.18 Code Option Select
0	BLDO_PD	Internal voltage regulator (main LDO) 1: Turn off main LDO 0: Turn on main LDO (default) Default value can be selected by section 6.18 Code Option Select

**-: unimplemented.**

**Note: Main LDO is turned off only on Green mode, if SOURCE clock is 12 MHz (IRC Internal or External crystal oscillator) main LDO must be turned on, otherwise system may work abnormally and leads to programming failure.**

**Note:** Due to WT51F104 only supports one set of external oscillator input, it requires setting the driving ability of oscillator according to the frequency of external oscillator input.

Please see the table below.

External Crystal Oscillator	CRY_12M_DR[1:0]
24 MHz	11
12 MHz	10
32.768 kHz	00

Below Code Option setting illustrates all Oscillator Power Switch Option setting, and it is recommended to set it according to its Reset value. If you want to use an external oscillator, please wait till MCU executes procedures.

**Clock Source Control Register IRC\_12M\_PD (XFR: 0x07)**
**Reset Value: A2h**

Bit	Bit 7	Bit 6	Bit 5	Bit 4	Bit 3	Bit 2	Bit 1	Bit 0
Status	-	-	-	R/W	R/W	R/W	R/W	-
Name	Reserved			IRC_12M_PD1	IRC_12M_PD2	IRC_32K_PD	CRY_12M_PD	Reserved

Bit Number	Bit Mnemonic	Description
7-5	-	Must be equal to "101", otherwise bit[4:0] cannot be written into
4	IRC_12M_PD1	1: Partial internal 12 MHz RC oscillator power is turned off (bias ON) (default value is not off) 0: Not off
3	IRC_12M_PD2	1: All internal 12 MHz RC oscillator power are closed (bias off) (default value is not off) 0: Not off
2	IRC_32K_PD	1: Internal 32 kHz RC oscillator power is turned off (default value is not off) 0: Not off
1	CRY_12M_PD	1: External 12 MHz crystal oscillator power is turned off (default value is off) 0: Not off
0	Reserved	-

**-: unimplemented.**

## 6.19 Read Out Protection & Encryption

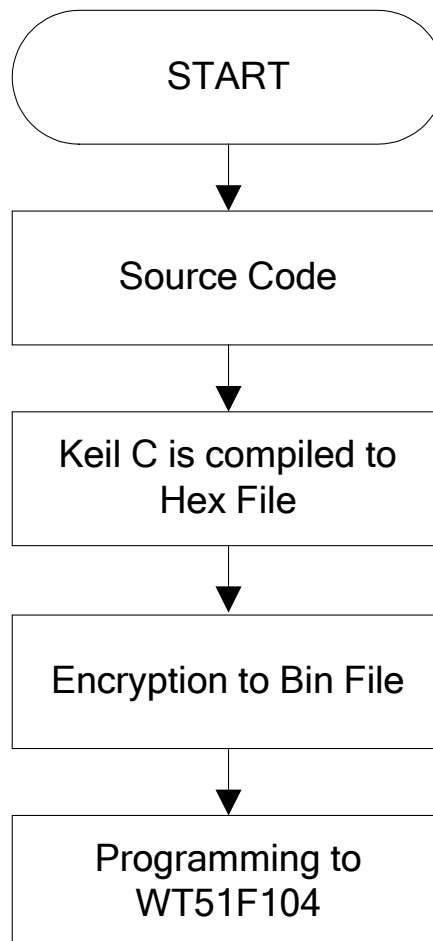

## 7. Electrical Characteristics

### 7.1 Absolute Maximum Ratings

Parameter	Symbol	Condition	Range	Units
D.C. Supply Voltage	$V_{DD}$		-0.3 ~ 6.0	V
Input Voltage	$V_I$		-0.3 to $V_{DD} + 0.3$	V
Output Voltage	$V_O$		-0.3 to $V_{DD} + 0.3$	V
Total current source by all GPIO	$\sum I_{OH}$		90@-40 °C ~ +85 °C	mA
Total current sink by all GPIO	$\sum I_{OL}$		90@-40 °C ~ +85 °C	mA
Ambient Temperature	$T_A$		-40 ~ 85	°C
Storage Temperature	$T_{STG}$		-60 ~ 125	°C

**Note:** Stresses above those listed may cause permanent damage to the devices.

### 7.2 Recommended Operating Parameters

Parameter	Symbol	Condition	Specification			Units
			Min	Typ.	Max	
Power Voltage	$V_{DD}$	$F_{main} = 12 \text{ MHz}$	1.8		5.5	V
Main Frequency	$F_{main}$	$V_{DD} = 1.8V \sim 5.5V$		12		MHz
Sub Frequency	$F_{sub}$	$V_{DD} = V_{DD}$		32.768		kHz
Operating Temperature	$T_{OPR}$		-40		85	°C
POR (Power on Reset) Level	$V_{POR}$	At $V_{DD_{TR}} = 30ms$ , $T_A = 25^\circ C$		1.15		V
VDD Rising Rate <sup>(*)</sup>	$V_{DD_{TRA}}$		50			$\mu S / V$
VDD Falling Rate <sup>(*)</sup>	$V_{DD_{TFA}}$		150			$\mu S / V$

**(\*):** These parameters are presented for design guidance only and not tested or guaranteed.

#### Power On Reset (POR) Timing

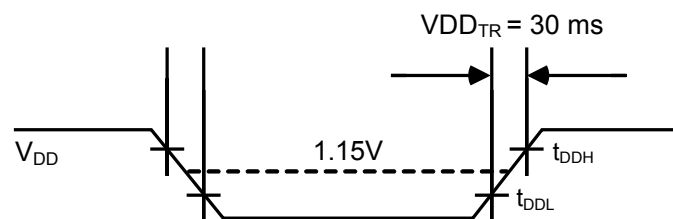

### 7.3 DC Electrical Characteristics ( $V_{DD} = 1.8V \sim 5V, -40^{\circ}C \sim +85^{\circ}C$ )

Parameter	Symbol	Condition	Specification			Units
			Min	Typ.	Max	
Schmitt Trigger from Low to High	$V_{T+}$	$V_{DD} = 1.8V \sim 5.5V$	$0.6 V_{DD}$		$V_{DD} + 0.3$	V
Schmitt Trigger from High to Low	$V_{T-}$	$V_{DD} = 1.8V \sim 5.5V$			$0.2 V_{DD}$	V
Output High Voltage (Note)	$V_{OH4}$	$I_{OH} = 4\text{ mA}$ at $V_{DD} = 5V$ GPIOB0 ~ GPIOB5, GPIOC0 ~ GPIOC5	$V_{DD} - 0.4$			V
	$V_{OH8}$	$I_{OH} = 8\text{ mA}$ at $V_{DD} = 5V$ GPIOA0 ~ GPIOA2, GPIOA4 ~ GPIOA5	$V_{DD} - 0.4$			
Output Low Voltage (Note)	$V_{OL4}$	$I_{OL} = 4\text{ mA}$ at $V_{DD} = 5V$ GPIOB0 ~ GPIOB5, GPIOC0 ~ GPIOC5			$V_{SS} + 0.4$	V
	$V_{OL8}$	$I_{OL} = 8\text{ mA}$ at $V_{DD} = 5V$ GPIOA0 ~ GPIOA2, GPIOA4 ~ GPIOA5			$V_{SS} + 0.4$	
Input Leakage Current <sup>(*)</sup>	$I_{OZ}$	$V_O = 0V$ or $V_{DD}$		$\pm 0.01$	$\pm 1$	$\mu A$
Pull-up Resistor	$R_{PH}$	$V_{DD} = 5V, V_{PIN} = 0V$		33		$K\Omega$
Normal mode at 12 MHz Working Current	$I_{VDD12M}$	No load on output ( $V_{DD} = 5V$ , IRC12M on), peripheral off		3.5		mA
Normal mode at 6 MHz Working Current	$I_{VDD6M}$	No load on output ( $V_{DD} = 5V$ , IRC12M on), peripheral off		2.1		mA
Normal mode at 3 MHz Working Current	$I_{VDD3M}$	No load on output ( $V_{DD} = 5V$ , IRC12M on), peripheral off		1.4		mA
Normal mode at 1 MHz Working Current	$I_{VDD1M}$	No load on output ( $V_{DD} = 5V$ , IRC12M on), peripheral off		0.9		mA
Idle mode Working Current	$I_{VDDs1}$	No load on output ( $V_{DD} = 5V$ , mcuClk = stop, Peripheral clock = IRC12M, BLDO on), peripheral off		600		$\mu A$

Parameter	Symbol	Condition	Specification			Units
			Min	Typ.	Max	
Green mode Working Current	$I_{VDDS2}$	No load on output ( $V_{DD} = 5V$ , mcuClk = IRC32K, Peripheral clock = IRC32K, BLDO off, LVR off), peripheral off		17		$\mu A$
Sleep mode Working Current	$I_{VDDS3}$	No load on output ( $V_{DD} = 5V$ , mcuClk = stop, Peripheral clock = stop, BLDO off, LVR off), peripheral off		5		$\mu A$

(\*): These parameters are presented for design guidance only and not tested or guaranteed.

Note:  $V_{OH4} / V_{OL4}$  pins maximum sink/source current are 10mA;  $V_{OH8} / V_{OL8}$  pins maximum sink/source current are 20mA.

## 7.4 AC Electrical Characteristics ( $T_A = 25^\circ C$ )

Parameter	Symbol	Pin/condition	Specification			Units
			Min	Typ.	Max	
Main Operation Frequency	$F_{MCP}$	$X_{IN}$	0.032		24	MHz
Main Crystal Stabilization Time <sup>(*)</sup>		$V_{DD} = 4.5V \sim 5.5V$ at 12 MHz			10	ms
		$V_{DD} = 1.8V \sim 4.5V$ at 12 MHz			30	ms
		$V_{DD} = 4.5V \sim 5.5V$ at 32768 Hz		0.5	1	s
		$V_{DD} = 1.8V \sim 4.5V$ at 32768 Hz			10	s
Interrupt Input High, Low Width (IRQx)	$t_{INTH}$ , $t_{INTL}$	MCU clock = 12 MHz	167			ns
RESET Input Low Width	$t_{RSL}$	RST_NDF = 1, main clock = 12 MHz	334			ns

(\*): These parameters are presented for design guidance only and not tested or guaranteed.

**Input Timing for External Interrupts**

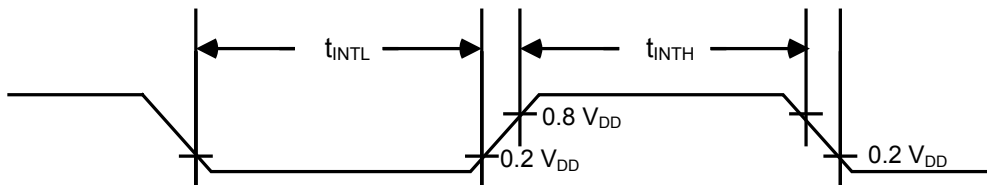

**Input Timing for RESET**

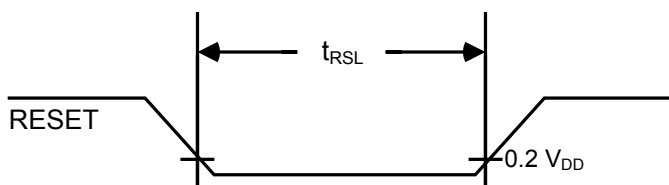

**7.5 Internal 12 MHz RC Oscillator Temperature Tolerance table**

Parameter	Symbol	Pin/condition	Specification			Units
			Min	Typ.	Max	
RC Oscillator Frequency	$F_{RCH}$	$V_{DD} = 5V$		12		MHz
Ex-factory Frequency Tolerance <sup>(*)</sup>	$\Delta F_{RCH1}/F_{RCH}$	Without external oscillator for calibrating 25°C		±1		%
		Without external oscillator for calibrating 0°C ~ 70°C		±2		%
		Without external oscillator for calibrating -40°C ~ 85°C		±3		%
		Without external oscillator for calibrating -40°C ~ 125°C		±4		%
		With external oscillator for calibrating -40°C ~ 125°C				±1

(\*): These parameters are presented for design guidance only and not tested or guaranteed.



## 7.6 A/D Converting Characteristics ( $T_A = 25^\circ\text{C}$ )

Parameter	Symbol	Pin/condition	Specification			Units
			Min	Typ.	Max	
Resolution				10		bit
Integral Nonlinearity Error (INL)	$E_{IL}$	$AV_{REF} = V_{DD} = 5V$		$\pm 2$		LSB
Differential Nonlinearity Error (DNL)	$E_{DL}$	$AV_{REF} = V_{DD} = 5V$		$\pm 2$		LSB
Analog Voltage Input Range	$V_{ADCIN}$		$V_{SS}$		$V_{REF}$	V
Conversion Time	$T_{CT}$	main clock = 12 MHz	16			ADC_clk
Reference Voltage <sup>(*)</sup>	$AV_{REF}$		2.5		$V_{DD}$	V
Ground Voltage <sup>(*)</sup>	$AV_{SS}$		$V_{SS}$		$V_{SS} + 0.3$	V
ADC Working Current <sup>(*)</sup>	$I_{ADC}$	$AV_{REF} = V_{DD} = 5V$		0.2		mA
		$AV_{REF} = V_{DD} = 5V$ at Power Down mode			1	$\mu A$

(\*): These parameters are presented for design guidance only and not tested or guaranteed.

### ADC ENOB (Effective number of bits)

Parameter	Pin/condition	Specification			Units
		Min	Typ.	Max	
ENOB	ADC convert time clock base = 1 MHz				
	$AV_{REF} = V_{DD} = 5V$		9		bit
	$AV_{REF} = V_{DD} = 4V$		8		bit
	$AV_{REF} = V_{DD} = 3V$		8		bit
	$AV_{REF} = V_{DD} = 2V$		8		bit
	$AV_{REF} = V_{DD} = 1.22V$ (Bandgap)		6		bit

## 7.7 Bandgap Electrical Characteristic

Parameter	Symbol	Pin/condition	Specification			Units
			Min	Typ.	Max	
Operating Voltage <sup>(*)</sup>			1.8		5.5	V
Operating Temperature <sup>(*)</sup>			-40		85	°C
Bandgap Voltage	V <sub>BDIE</sub>	V <sub>DD</sub> = 5V Temp = 25°C		1.22 ±15%		V
Voltage Variation	V <sub>BSP</sub>	V <sub>DD</sub> = 1.8V ~ 5.5V		50		mV
Temperature Variation	V <sub>BTP</sub>	Temp = -40°C ~ 85°C		30		mV

(\*): These parameters are presented for design guidance only and not tested or guaranteed.

Note: Internal reference voltage Bandgap is not calibrated out of the factory, and will be affected by the impact of temperature and supply voltage. Please refer to the section 6.13 for the actual voltage value.

## 7.8 Low Voltage Reset (LVR), Low Voltage Detection (LVD) & Low Voltage Detection Reset (LVDR) Electrical Characteristics (T<sub>A</sub> = 25°C)

Parameter	Symbol	Pin/condition	Specification			Units
			Min	Typ.	Max	
LVR Voltage	V <sub>LVR</sub>	T <sub>A</sub> = 25°C		1.5		V
LVR Working Current	I <sub>DDPR</sub>	V <sub>DD</sub> = 5V ±10%		5		μA
LVD & LVDR Response Time				120		μS
Low Voltage Detection Range Tolerance	V <sub>LVD</sub>			10		%
Low Voltage Detection Reset Range Tolerance	V <sub>LVDR</sub>			10		%

## 7.9 Comparator Characteristics (V<sub>DD</sub> = 5V, T<sub>A</sub> = 25°C)

Parameter	Symbol	Pin/condition	Specification			Units
			Min	Typ.	Max	
Comparator Input Voltage Range	V <sub>ICM</sub>		V <sub>SS</sub>		V <sub>DD</sub>	V
Input Offset Voltage	V <sub>IOS</sub>			±5		mV
Response Time	T <sub>RT</sub>			1		μs

Parameter	Symbol	Pin/condition	Specification			Units
			Min	Typ.	Max	
Setting Time <sup>(*)</sup>	T <sub>ST</sub>	V <sub>DD</sub> = 5 V		3	10	μs
32-level Reference Voltage Tolerance	V <sub>REF</sub>			10		%
Comparator Current	I <sub>CMP</sub>	ACOMP_SEL_BGP [1:0] = 00		20		μA

(\*): These parameters are presented for design guidance only and not tested or guaranteed.

## 7.10 Thermal Resistance Notice

Parameter	Symbol	Feature	Typ.	Units	Condition
TH01	$\theta_{JA}$	Thermal Resistance (Junction to Air)	90	°C/W	20-pin SSOP package
TH02	$\theta_{JC}$	Thermal Resistance (Junction to Case)	30	°C/W	20-pin SSOP package
TH03	TJMAX	Maximum Junction Temperature	125	°C	20-pin SSOP package

Parameter	Symbol	Feature	Typ.	Units	Condition
TH01	$\theta_{JA}$	Thermal Resistance (Junction to Air)	90	°C/W	14-pin SOP package
TH02	$\theta_{JC}$	Thermal Resistance (Junction to Case)	37	°C/W	14-pin SOP package
TH03	TJMAX	Maximum Junction Temperature	125	°C	14-pin SOP package

Parameter	Symbol	Feature	Typ.	Units	Condition
TH01	$\theta_{JA}$	Thermal Resistance (Junction to Air)	45	°C/W	10-pin MSOP package
TH02	$\theta_{JC}$	Thermal Resistance (Junction to Case)	120	°C/W	10-pin MSOP package
TH03	TJMAX	Maximum Junction Temperature	125	°C	10-pin MSOP package

Parameter	Symbol	Feature	Typ.	Units	Condition
TH01	$\theta_{JA}$	Thermal Resistance (Junction to Air)	150	°C/W	8-pin SOP package
TH02	$\theta_{JC}$	Thermal Resistance (Junction to Case)	39	°C/W	8-pin SOP package
TH03	TJMAX	Maximum Junction Temperature	125	°C	8-pin SOP package

## 8. Application Circuits

### 8.1 Power Supply

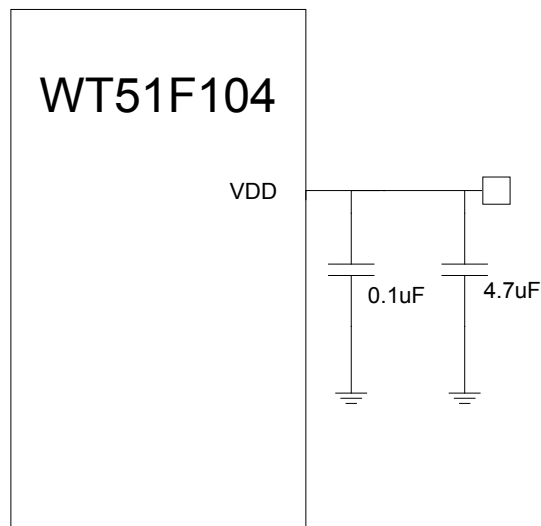

### 8.2 Oscillator Circuits

#### 8.2.1 External 12 MHz Crystal Oscillator

Example

Crystal Oscillator	C1, C2 = 10pF ~ 33pF
Ceramic Resonator	C1, C2 = 10pF ~ 33pF

\* The example load capacitor value (C1, C2, C3, C4) is common value but may not be appropriate for some crystal or ceramic resonator.

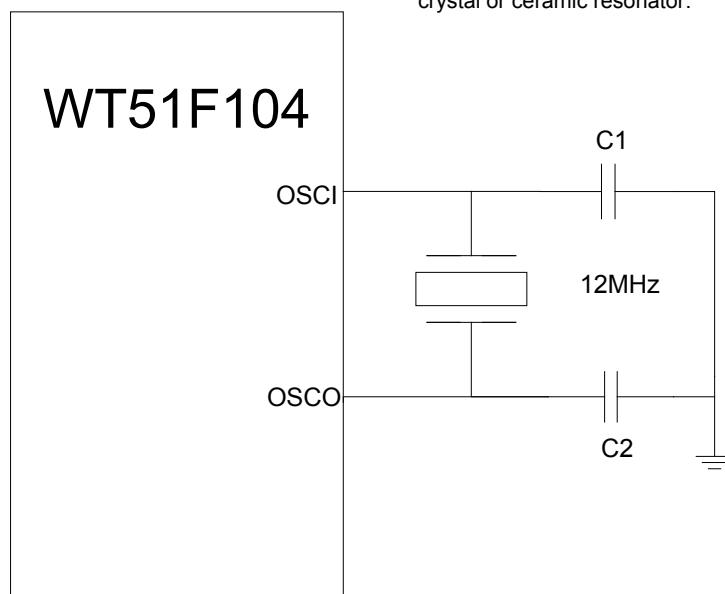

**Note: WT51F104 has built-in internal RC oscillators, thus external crystal oscillators are not essential. If for more precise application, external crystal oscillator is available for use.**

### 8.2.2 External 32.768 kHz Crystal Oscillator

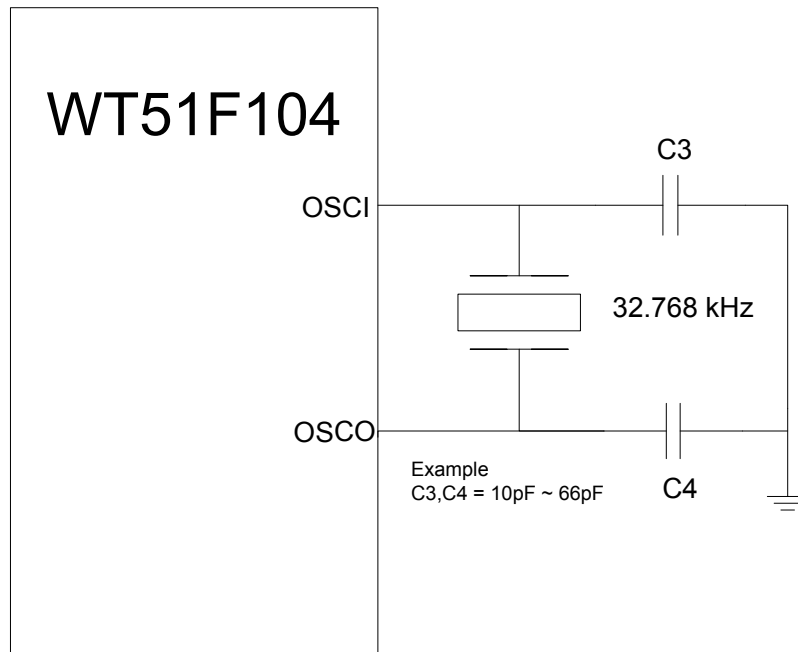

### 8.3 RESET Circuit

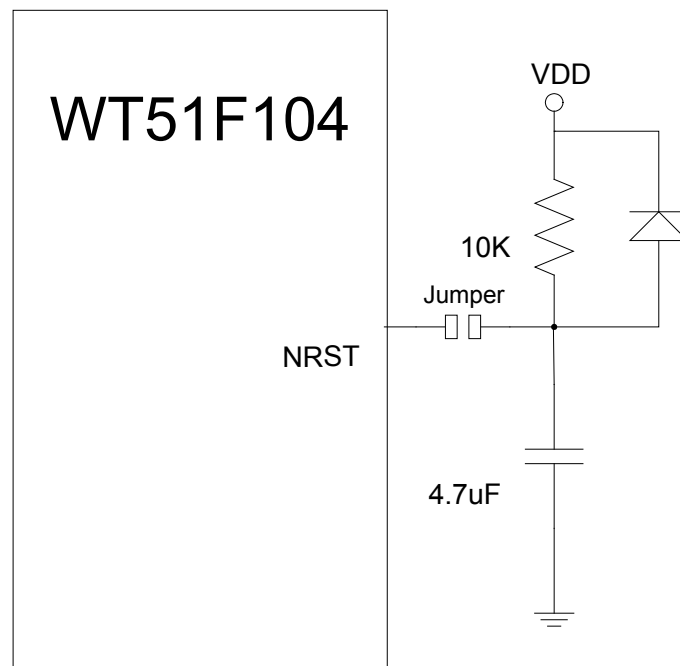

**Note: Reset Circuit will influence programming process, and it requires adding Jumper for isolation.**

**8.4 Standard Circuit**

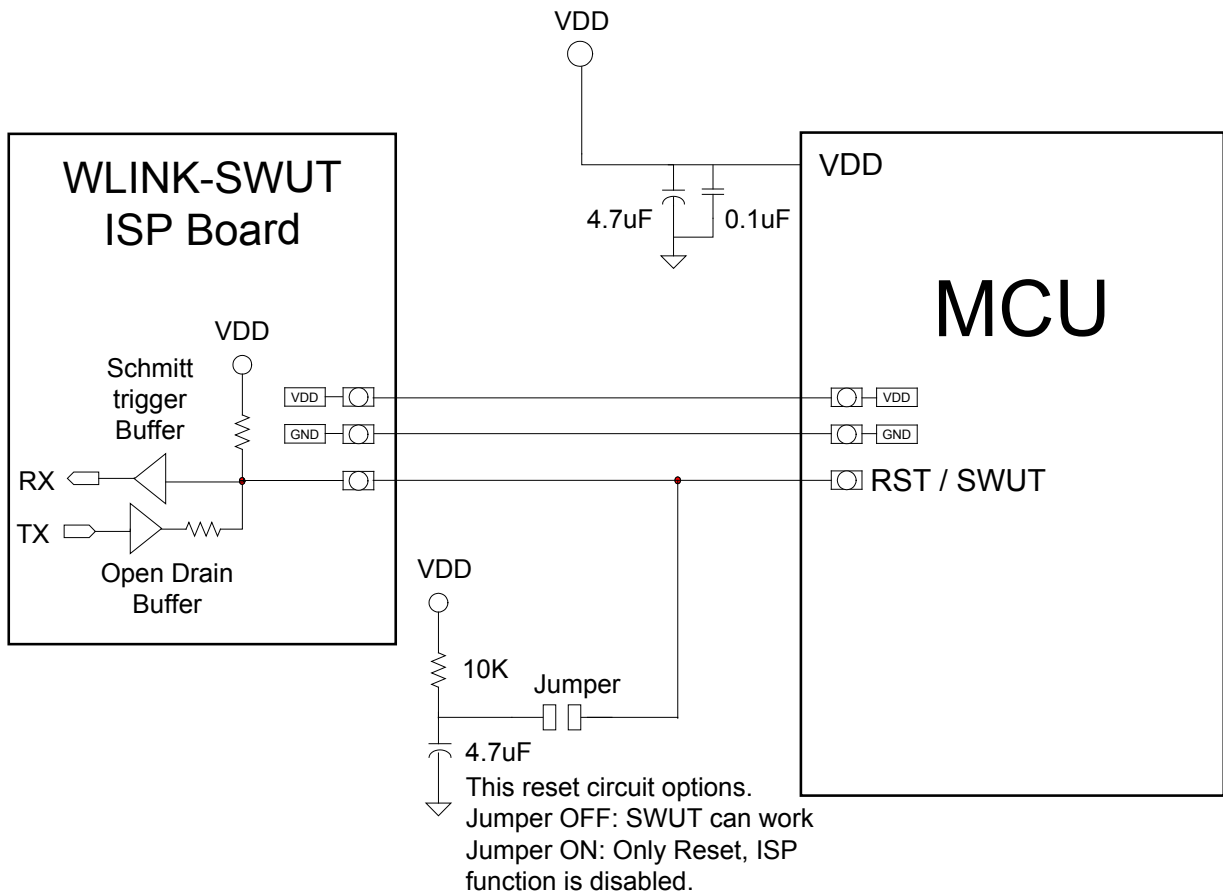

**Note: The current version of WLINK-SWUT only supports  $V_{DD} = 5V$  programming (version: WLINK-SWUT 20120120). In next version,  $V_{DD} = 2.2V \sim 5.5V$  programming will be supported.**

**8.5 Development board circuits (16\*2 LCM)**

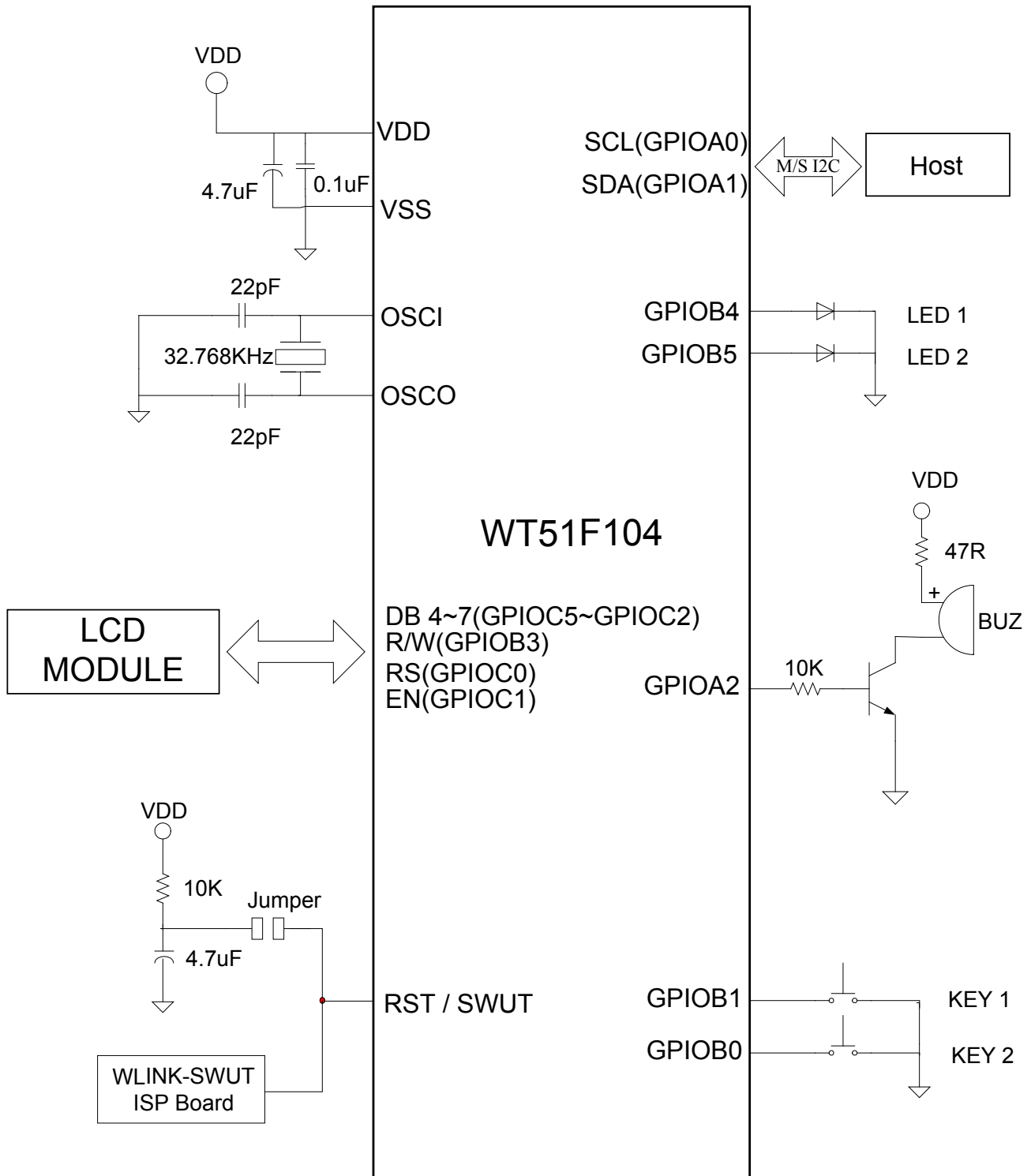

## 9. Product Naming Rule

WT	Consumption market	LCD function	Seed code (Family)	Flash Size (K Bytes)		Remarks
WT	5	1F	1	0	4	5: MCU/DSP embedded, used in general-purpose or consumption market related product. 1X: 8-bit MCU 1F: Flash type 8-bit MCU without LCD function
			5	1	6	
WT	5	6F	1	0	8	5: MCU/DSP embedded, used in general-purpose or consumption market related product. 6X: LCD back light module controller 6F: Flash type 8-bit MCU with LCD function
			2	1	6	

## 10. Ordering Information

Package Type	Package Outline	Part Number
20-pin SSOP	150 mil	WT51F104-OG20AWT
14-pin SOP	150 mil	WT51F104-SG140WT
10-pin MSOP	118 mil	WT51F104-MG10AWT
8-pin SOP	150 mil	WT51F104-SG080WT
Wafer form or Chip form	-	WT51F104HXXXWT



## 11. Pad Diagram & Location Table

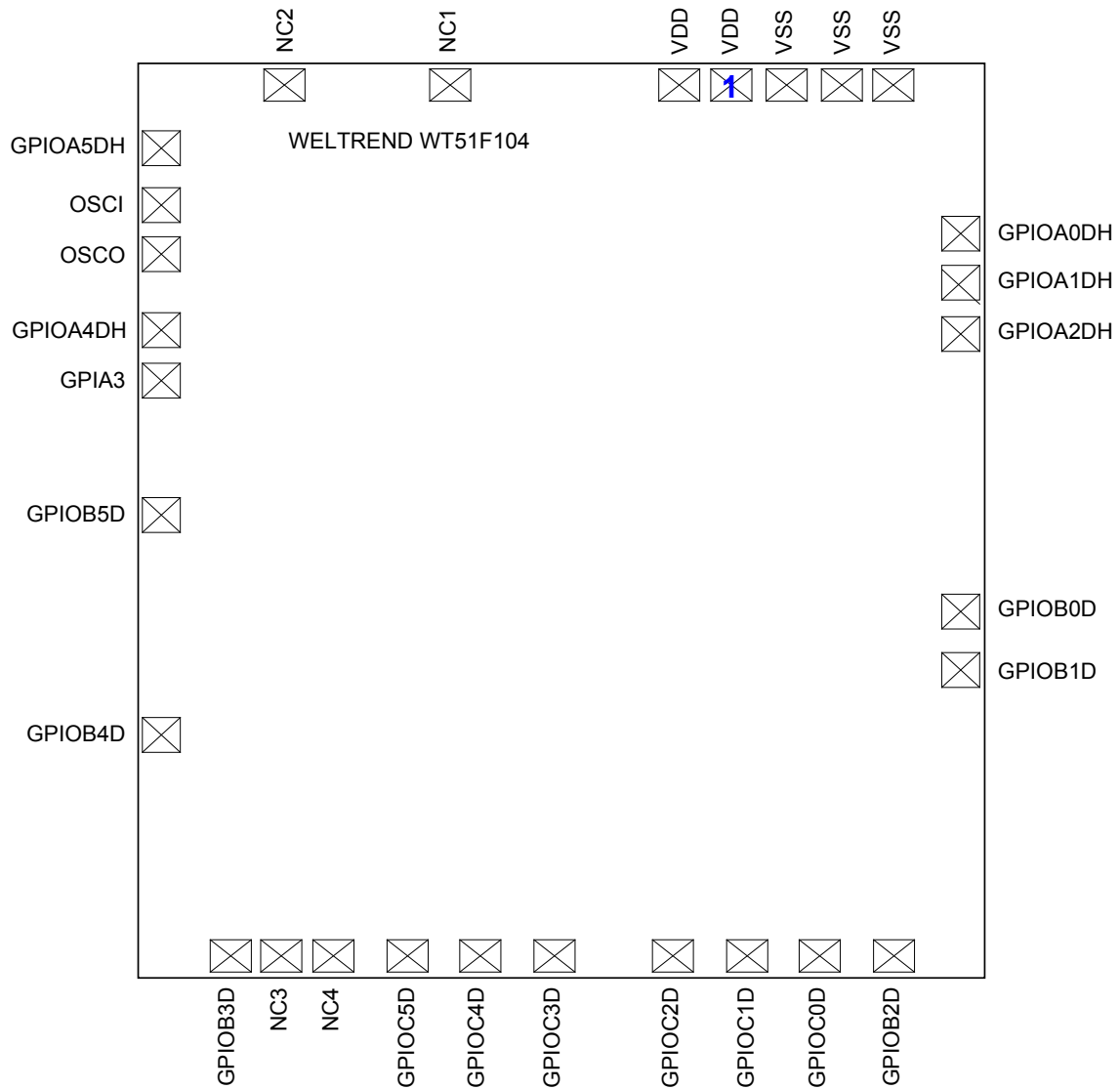

No	Name	X	Y	No	Name	X	Y
1	VDD	1069.05	1678.55	16	GPIOC4D	618.95	46.45
2	VDD	976.05	1678.55	17	GPIOC3D	751.95	46.45
3	NC1	563.61	1678.55	18	GPIOC2D	964.05	46.45
4	NC2	266.23	1678.55	19	GPIOC1D	1097.05	46.45
5*	GPIOA5DH	46.45	1558.05	20	GPIOC0D	1230.05	46.45
6*	OSCI	46.45	1454.55	21	GPIOB2D	1363.05	46.45
7*	OSCO	46.45	1361.55	22*	GPIOB1D	1483.55	577.99
8*	GPIOA4DH	46.45	1219.41	23*	GPIOB0D	1483.55	688.82
9*	GPIA3	46.45	1126.41	24*	GPIOA2DH	1483.55	1212.415
10*	GPIOB5D	46.45	873.41	25*	GPIOA1DH	1483.55	1305.415
11*	GPIOB4D	46.45	460.41	26*	GPIOA0DH	1483.55	1398.415
12	GPIOB3D	166.95	46.45	27	VSS	1363.05	1678.55
13	NC3	259.95	46.45	28	VSS	1270.05	1678.55
14	NC4	352.95	46.45	29	VSS	1169.55	1678.55
15	GPIOC5D	485.95	46.45				

**Notes:**

1. *The origin of pad location shown here is at lower-left corner of die.*
2. **PAD Window**
  - (a) *A type: 73um x 66um*
  - (b) *B type: 66 um x 73um (\*)*
3. *To stabilize the supply voltages, please connect 0.1uF and 4.7uF bypass capacitors between VDD and VSS.*
4. *NC1, NC2, NC3, NC4 pins, no connection for normal application.*
5. *All VDD pin need connect together. (No: 1, 2)*
6. *All VSS pin need connect together. (No: 27, 28, 29)*

## 12. Package Dimension

### 12.1 20-Pin SSOP

Shrink Small Outline Package

150MIL/SSOP-20PIN

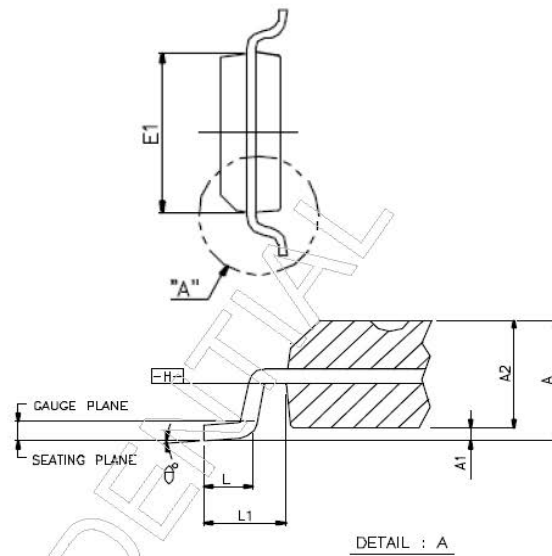
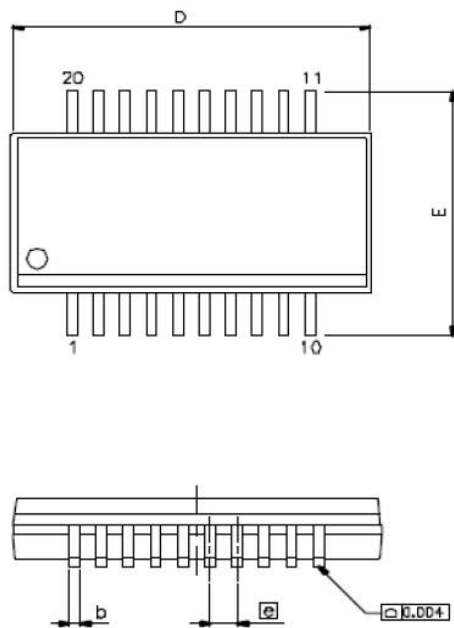

SYMBOLS	MIN	NOR	MAX
A	1.346	1.626	1.753
A1	0.102	0.152	0.254
A2	-	-	1.499
b	0.203	-	0.305
C	0.178	-	0.254
D	8.560	8.661	8.738
E	5.791	5.994	6.198
E1	3.810	3.912	3.968
e	0.635 BSC		
L	0.406	0.635	1.270
L1	1.041 BSC		
θ°	0	-	8

UNIT: mm

**NOTES:**

- JEDEC outline : MO-137AD
- Dimension "D" does not include mold protrusion or gate burrs. Mold protrusions and gate burrs shall not exceed 0.152mm per side. Dimension "E1" does not include inter-lead mold protrusions. Inter-lead mold protrusion shall not exceed 0.254mm per side.
- Dimension "b" does not include dambar protrusion/intrusion. Allowable dambar protrusion shall be 0.102mm total in excess of "b" dimension at maximum material condition. Dambar intrusion shall not reduce dimension "b" by more than 0.051mm at least.

PREPARE	Cynthia	DATE: 2012/7/26
CHECK	Lawrence	DATE: 2012/7/26
APPROVE	Eric	DATE: 2012/7/26

**12.2 14-Pin SOP**

**Small Outline Package**

**150MIL/SOP-14 PIN**

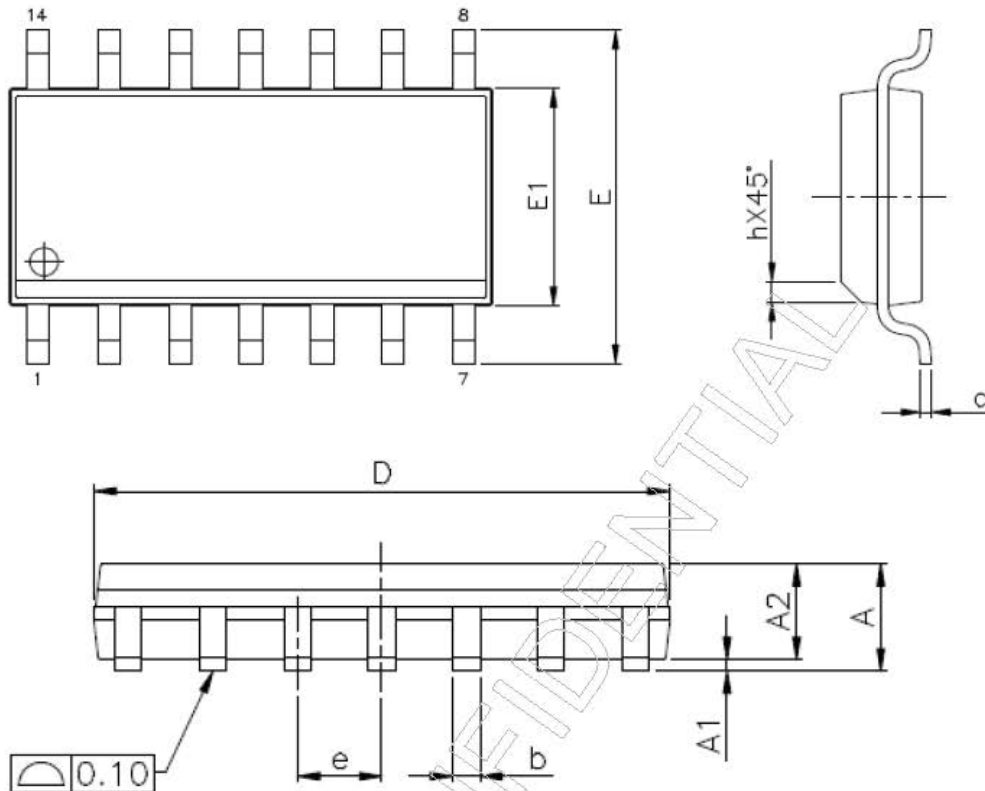

SYMBOLS	MIN	MAX
A	-	1.75
A1	0.10	0.25
A2	1.25	-
b	0.31	0.51
c	0.10	0.25
D	8.65 BSC	
E	6.00 BSC	
E1	3.90 BSC	
e	1.27 BSC	
L	0.40	1.27
h	0.25	0.50
θ°	0	8

UNIT: mm

**NOTES:**

1. JEDEC outline : MS-012 AB REV.F
2. Dimension "D" does not include mold flash, protrusions or gate burrs. Mold flash, protrusions and gate burrs shall not exceed 0.15mm per side.
3. Dimension "E1" does not include inter-lead flash, or protrusions. Inter-lead flash and protrusions shall not exceed 0.25mm per side.

PREPARE	Cynthia	DATE: 2012/7/24
CHECK	Lawrence	DATE: 2012/7/24
APPROVE	Eric	DATE: 2012/7/24

**12.3 10-Pin MSOP**

**Micro Small Outline Package**

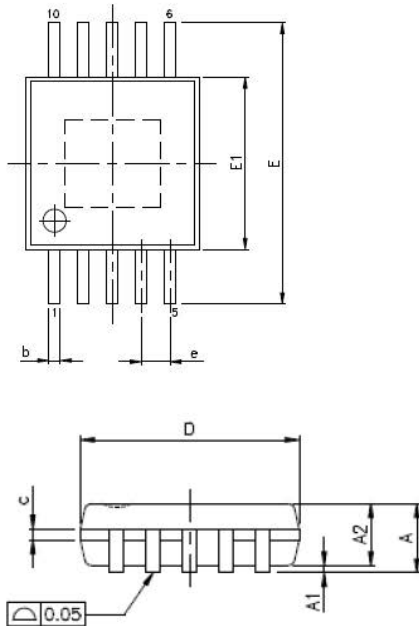

**MSOP-10 PIN**

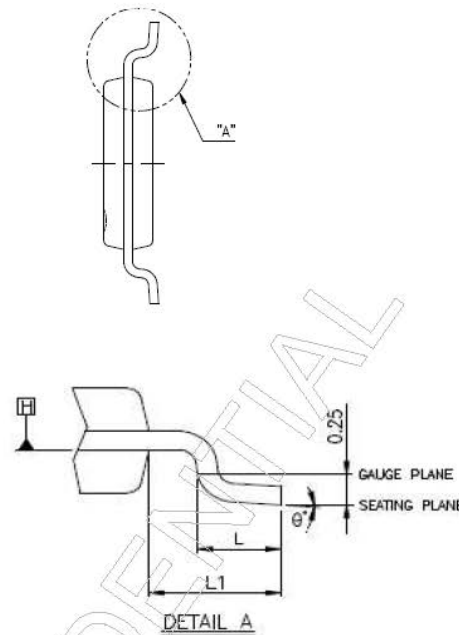

SYMBOLS	MIN	NOR	MAX
A	-	-	1.10
A1	0.00	-	0.15
A2	0.75	0.85	0.95
b	0.17	-	0.27
c	0.08	-	0.23
D	3.00 BSC		
E	4.90 BSC		
E1	3.00 BSC		
e	0.50 BSC		
L	0.40	0.60	0.80
L1	0.95 REF		
$\theta^\circ$	0	-	8

UNIT: mm

**NOTES:**

1. JEDEC outline : MO-187 BA
2. Dimension "D" does not include mold flash, protrusions or gate burrs. Mold flash, protrusions or gate burrs shall not exceed 0.15mm per end. Dimension "E1" does not include inter-lead flash or protrusion. Inter-lead flash or protrusion shall not exceed 0.15mm per side.
3. Dimension "b" does not include dambar protrusion. Allowable dambar protrusion shall be 0.08mm total in excess of the "b" dimension at maximum material condition. The dambar cannot be located on the lower radius of the foot. Minimum space between protrusion and an adjacent lead shall not be less than 0.07mm.
4. "D" and "E1" dimensions are determined at datum H.

PREPARE	Cynthia	DATE: 2012/7/25
CHECK	Lawrence	DATE: 2012/7/25
APPROVE	Eric	DATE: 2012/7/25

**12.4 8-Pin SOP**

**Small Outline Package**

**150MIL/SOP-8 PIN**

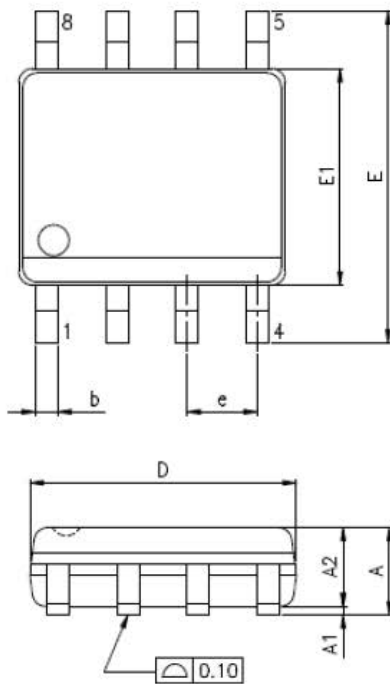

UNIT: mm

SYMBOLS	MIN	MAX
A	-	1.75
A1		0.25
A2	1.25	-
b	0.31	0.51
c	0.10	0.25
D	4.90 BSC	
E	6.00 BSC	
E1	3.90 BSC	
e	1.27 BSC	
L	0.40	1.27
h	0.25	0.50
θ°	0	8

UNIT: mm

**NOTES:**

1. JEDEC outline : MS-012 AA REV.F
2. Dimension "D" does not include mold flash, protrusions or gate burrs. Mold flash, protrusions and gate burrs shall not exceed 0.15mm per side.
3. Dimension "E1" does not include inter-lead flash, or protrusions. Inter-lead flash and protrusions shall not exceed 0.25mm per side.

PREPARE	Cynthia	DATE: 2012/7/24
CHECK	Lawrence	DATE: 2012/7/24
APPROVE	Eric	DATE: 2012/7/24

## 13. Development Tools

WT51F104 can work together with Keil C51 development environment. WLINK adaptor can link PC and WT51F104 evaluation board via ICE/ISP driver, and the debugger tools, demo board application software can perform In-Circuit Emulator (ICE) and In-system Programming (ISP) in Windows 98/2000/XP/Win7.

The development kits are illustrated in the figure below:

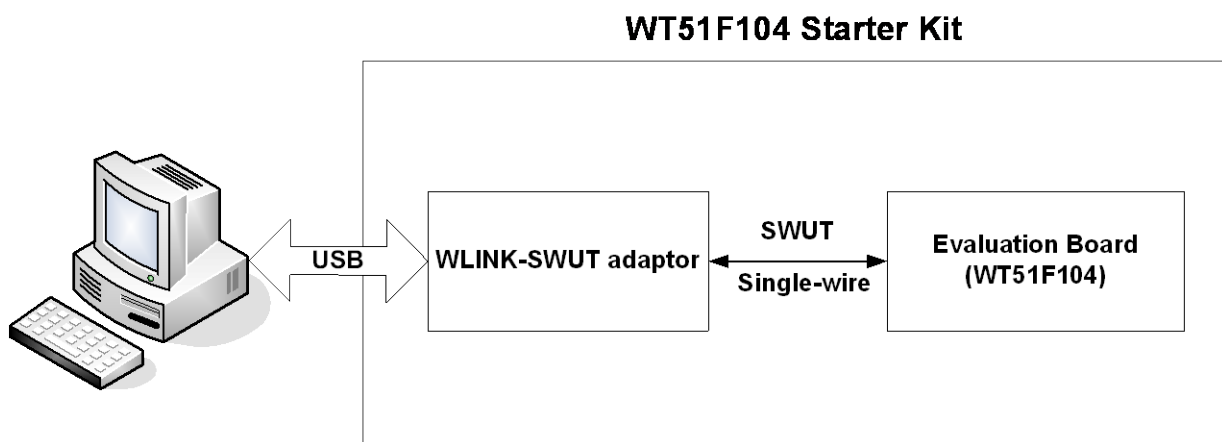

**Development Tools List:**

 Please go to Weltrend's website <http://www.weltrend.com.tw/> for more information.

<b>Product Information</b>	<b>General Purpose IC</b>	ADC Type MCU	WT51F104 Product Spec
			WT51F116/WT51F108 Product Spec
		ADC+LCD Type MCU	WT56F216 Product Spec
			WT56F108 Product Spec
			WT56F248/WT56F232 Product Spec
<b>Technical Support</b>	<b>Supporting Tools/ General Purpose IC</b>	ICE/ISP	<b>WA001</b> WLINK-SWUT Adapter
		Mass Production Programming	<b>WA007 WLINK-SWUT-M4S</b>
		Mass Production Programming Daughter Board	<b>WS001</b> WLINK-SWUT-M4S Daughter Board Support WT56F216/ <b>WT56F232/WT56F248</b> MCU RG44AWT LQFP 44 PKG
			<b>WS003</b> WLINK-SWUT-M4S Daughter Board Support WT56F216 MCU SG28AWT SOP28 PKG
			<b>WS004</b> WLINK-SWUT-M4S Daughter Board Support WT51F104/WT51F116/WT51F108 MCU OG20AWT SSOP20 PKG
			<b>WS005</b> WLINK-SWUT-M4S Daughter Board Support WT51F104 MCU SG140WT SOP14 PKG SG080WT SOP8 PKG
			<b>WS006</b> WLINK-SWUT-M4S Daughter Board Support WT51F104 MCU MG10AWT MSOP10 PKG
			<b>WS007</b> WLINK-SWUT-M4S Daughter Board Support WT56F108 MCU RG64AWT LQFP64 PKG
			<b>WS009</b> WLINK-SWUT-M4S Daughter Board Support WT51F116/WT51F108 MCU UG32AWT QFN32 PKG
			<b>WS010</b> WLINK-SWUT-M4S Daughter Board Support WT51F116/WT51F108 MCU MG10BWT MSOP10 PKG
			<b>WS011</b> WLINK-SWUT-M4S Daughter Board Support WT56F248/WT56F232 MCU RG64AWT LQFP64 PKG
			<b>WS012</b> WLINK-SWUT-M4S Daughter Board Support WT56F248/WT56F232 MCU UG32AWT QFN32 PKG
			<b>WS013</b> WLINK-SWUT-M4S Daughter Board Support WT56F108 MCU RG44AWT LQFP 44 PKG
			<b>WS014</b> WLINK-SWUT-M4S Daughter Board Support WT56F108 MCU SG28AWT SOP28 PKG



<b>Technical Support</b>	<b>Supporting Tools/ General Purpose IC</b>	Evaluation Board	<b>WB000</b> WT56F216 EV Board
			<b>WB001</b> WT51F104 EV Board
			<b>WB005</b> WT56F216 Starter Kit Board
			<b>WB006</b> WT51F104 Starter Kit Board
			<b>WB007</b> WT56F108 Starter Kit Board
			<b>WB008</b> WT51F116/WT51F108 Starter Kit Board
			<b>WB010</b> WT56F248/WT56F232 Starter Kit Board
	<b>Supporting Tools/ General Purpose IC</b>	Starter Kit	<b>WK000</b> WT56F216 Starter Kit
			<b>WK001</b> WT51F104 Starter Kit
			<b>WK004</b> WT56F108 Starter Kit
			<b>WK005</b> WT51F116/WT51F108 Starter Kit
			<b>WK007</b> WT56F248/WT56F232 Starter Kit
	<b>Technical Data/ General Purpose IC</b>	WLINK Adapter Operation Manual	<b>Doc2</b> WLINK-SWUT Adapter Installation Manual
		Mass Production Programming Operation Manual	<b>Doc26</b> WLINK-SWUT- <b>M4S</b> Operation Manual
		ICE/ISP Operation Manual	<b>Doc6</b> WLINK ICE Operation Manual (uVision IDE Version)
			<b>Doc8</b> WLINK-SWUT ISP Operation Manual (Independent Version)
		Evaluation Board Operation Manual	<b>Doc12</b> WT56F216 EV Board Operation Manual
			<b>Doc13</b> WT51F104 EV Board Operation Manual
			<b>Doc21</b> WT56F216 Starter Kit Quick Start Guide
			<b>Doc22</b> WT51F104 Starter Kit Quick Start Guide
			<b>Doc23</b> WT56F216 Starter Kit Operation Manual
<b>Doc24</b> WT51F104 Starter Kit Operation Manual			
<b>Doc27</b> WT56F108 Starter Kit Operation Manual			
<b>DOC28</b> WT51F116/WT51F108 Starter Kit Operation Manual			
<b>DOC30</b> WT56F248/WT56F232 Starter Kit Operation Manual			
Mass Production ISP and Supplier Contact Information		<b>Doc20</b> Mass Production ISP Supplier	

<b>Technical Support</b>	<b>Software Download/ General Purpose IC</b>	WLINK Adapter Driver	<b>SW2</b> WLINK-SWUT Adapter Driver
		Mass Production Programming Driver	<b>SW2</b> WLINK-SWUT Adapter Driver
		ICE Driver/ISP Program	<b>SW6</b> WLINK-SWUT ICE Driver (for uVision IDE)
			<b>SW8</b> WLINK-SWUT ISP Driver (for uVision IDE)
			<b>SW9</b> WLINK-SWUT ISP Program (for Alone Programmer)
			<b>SW17</b> Auto Install WLINK-SWUT ICE & ISP Driver (for uVision IDE) WLINK-SWUT ISP Driver (for uVision IDE)
		Example Program	<b>SW13</b> WT56F216 EV Board Example Program
			<b>SW14</b> WT51F104 EV Board Example Program
			<b>SW18</b> WT56F216 Starter Kit Board Example Program
			<b>SW19</b> WT51F104 Starter Kit Board Example Program
			<b>SW21</b> WT56F108 Starter Kit Board Example Program
			<b>SW22</b> WT51F116/WT51F108 Starter Kit Board Example Program
			<b>SW25</b> WT56F248/WT56F232 Starter Kit Board Example Program

## 14. Revision History

<b>Version</b>	<b>History</b>	<b>Date</b>
1.0	Initial issue	Dec. 2011
1.05	Revision, see Errata for more details	June 2012
2.0	Revision, see Errata for more details	July 2013
3.0	Revision, see Errata for more details (20140630)	June 2014
	Revision, see Errata for more details (20140919)	Sep. 2014
	Revision, see Errata for more details (20141226)	Dec. 2014

## Appendix: Errata

V2.0 -> V3.0

Item	Page	Chapter	Modification
1	3	2	Add Green Package description
2	8-10	4.1	Pin Description
3	11	4.2	Pin Summary content
4	17	5.3	Add Note
5	41, 43	6.2.3	XFR: 0x25, 0x27, 0x28 content
6	46-47	6.2.3	Complex Function table
7	73-74	6.6	XFR: 0x57, 0x58 content
8	95	6.9.1	XFR: 0x0A content
9	113	6.13	ADC content
10	120	6.14	XFR: 0xDB content
11	127	6.17	Contents modify
12	129	6.17	Contents modify
13	129	6.18	Code option content
14	134	6.18	XFR: 0x25 content
15	158-160	13	Development Tools List update