

WT7181R

Multi-Mode Flyback PWM Controller

Product Spec.

Rev. 0.2

September 2020

Copyright Notice

This data sheet is copyrighted by Weltrend Semiconductor, Inc. Do not reproduce, transform to any other format, or send/transmit any part of this documentation without the express written permission of Weltrend Semiconductor, Inc.

Disclaimers

Right to make change –

This document provides technical information for user. Weltrend Semiconductor, Inc. reserves the right to make change without further notice to any products herein.

Table of Contents

1. General Description	2
2. Features	2
3. Block Diagram	3
4. Pin Configuration	4
4.1 PIN DESCRIPTION.....	4
5. Function Description	5
5.1 STARTUP CIRCUIT AND UNDER VOLTAGE LOCKOUT (UVLO).....	5
5.2 MULTI-MODE OPERATION FOR HIGH EFFICIENCY.....	6
5.3 OPEN LOOP PROTECTION (OLP).....	6
5.4 GATE CLAMP/SOFT DRIVING.....	6
5.5 DC BROWN IN/OUT, OUTPUT OVP AND UVP ON VS PIN.....	6
5.6 ADJUSTABLE OVER CURRENT LINE COMPENSATION.....	8
5.7 ADAPTIVE GREEN MODE CONTROL.....	8
5.8 CS PIN SHORT PROTECTION.....	8
6. Electrical Characteristics	9
6.1 ABSOLUTE MAXIMUM RATINGS.....	9
6.2 RECOMMENDED OPERATING PARAMETERS.....	9
6.3 THERMAL RESISTANCE.....	10
6.4 VERSION TABLE.....	10
6.5 ELECTRICAL CHARACTERISTICS.....	10
7. Simplified Application Circuit	13
8. Ordering Information	14
9. Package Information	15
9.1 PACKAGE DIMENSIONS.....	15
10. Revision History	16

1. General Description

The WT7181R is a high performance multi-mode (CCM/Valley Switching) Flyback PWM controller. It is specifically designed to work with USB PD controller to provide a total solution for quick cell phone charger or USB PD. It minimizes the components counts and is available in a tiny SOT-26 package. The controller operates in Continuous Current Mode (CCM) during heavy load and operates in discontinuous conduction mode with valley switching during light load. The WT7181R helps to improve the overall efficiency and optimize the product performance. The controller provides with important protection features, such as DC Brown In/Out, Vo UVP, VDD OVP, OLP, OCP and Output Short Circuit Protection.

2. Features

- Ultra-low Start-up current (1.5 μ A Typ.)
- Optimized for Wide Output Voltage Operation
 - ◆ Wide VDD Range: 7.5V to 68V (Typ.)
 - ◆ Adjustable OCP Line Compensation
 - ◆ Adaptive Green Mode Control
 - ◆ No External VDD Linear Regulator Circuit
 - ◆ Only One VDD Auxiliary Winding
- CCM/DCM/Valley-Switching Multi-Mode Operation
- DRV pin with Soft Driver to Reduce EMI Noise
- Internal Soft-Start Function
- Protection:
 - ◆ DC Brown In/Out Protection on VS Pin
 - ◆ Output Under Voltage Protection (VS_UVP)
 - ◆ Output Over Voltage Protection (VS_OVP)
 - ◆ VDD Over Voltage Protection (VDD_OVP)
 - ◆ Open Loop Protection (OLP) when Feedback Loop Open
 - ◆ Over Current Protection (OCP)
 - ◆ Internal Over Temperature Protection
 - ◆ CS Pin Open/Short Protection
 - ◆ Output Rectifier Short Protection
- Package: SOT-26

3. Block Diagram

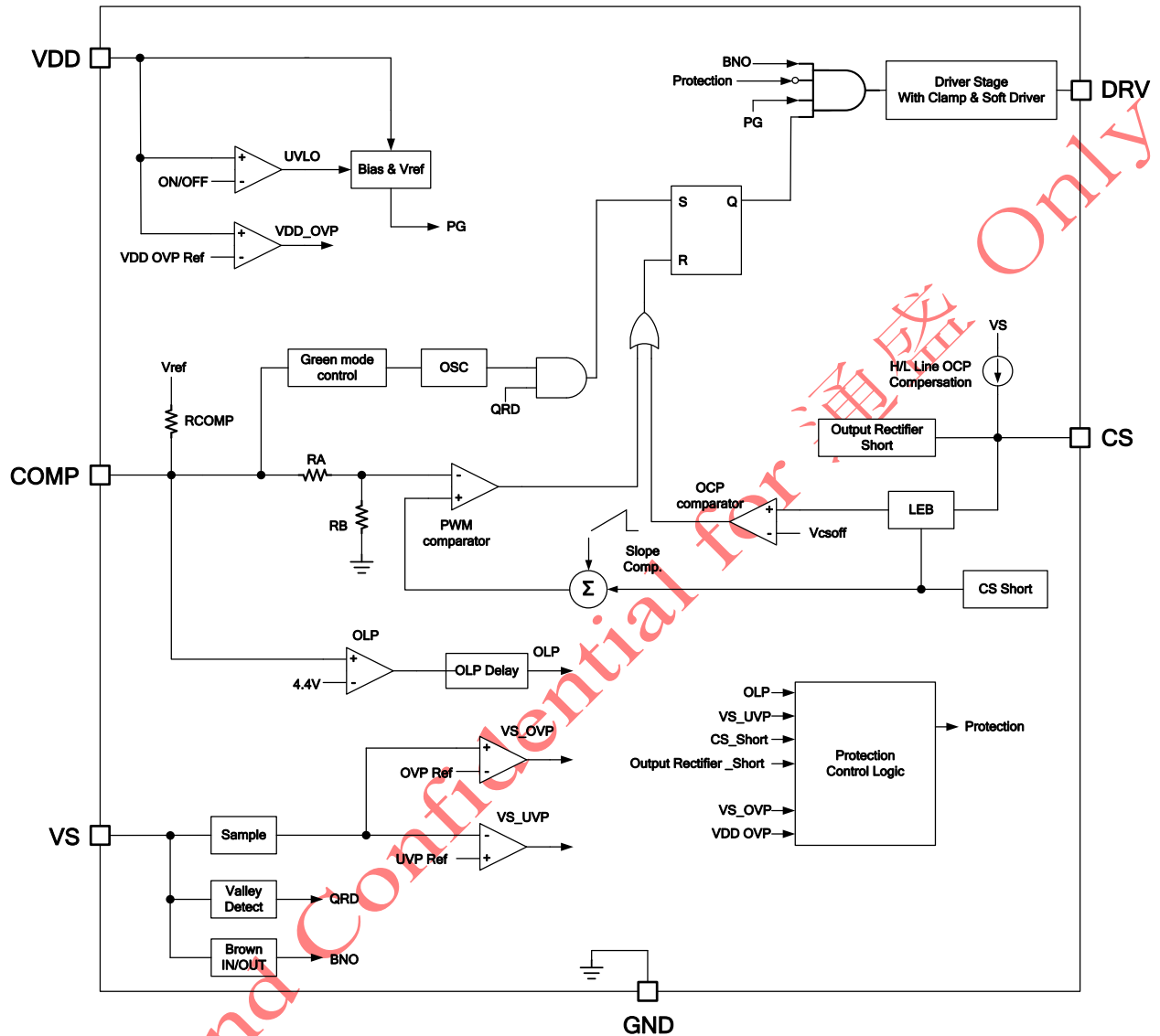

4. Pin Configuration

6-pin SOT-26

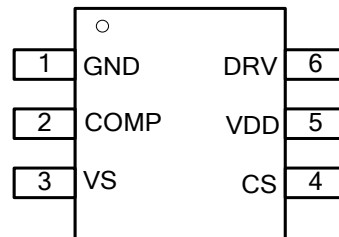

4.1 Pin Description

Pin Number	Pin Name	Description
SOT-26		
1	GND	Ground
2	COMP	This pin connects to a Photo-coupler collector and adjusts the peak current set point.
3	VS	This pin connects to a voltage divider between an auxiliary winding and detects the core demagnetization to have the controller operated at the valley switching for DCM. This pin provides the output over-voltage and under-voltage detection. This pin also provides external dc brown in/out protection.
4	CS	The current sense pin monitors and control the primary peak current.
5	VDD	This pin is connected to an external auxiliary voltage and supplies the controller.
6	DRV	This pin drives the gate of external MOSFET switch.

5. Function Description

The WT7181R is a high performance multi-mode (CCM/Valley Switching) Flyback PWM controller. It is specifically designed to work with the USB PD controller or programmable power adapter controller, to provide a total solution. For the wide output voltage application, the WT7181R features many new innovations, including wide VDD range, OCP line compensation and adaptive green mode control. Its major features are described as below.

5.1 Startup Circuit and Under Voltage Lockout (UVLO)

The typical start-up current is 1.5 μ A. Very low start-up current allows the PWM controller to increase the value of start-up resistor and then reduce the power dissipation on it. To minimize power loss, it's recommended to connect the start-up circuit to the bleeding resistors, as shown in Fig 5.1. At startup, R_{S1} and R_{S2} will provide the startup current to charge the capacitor C_{VDD} which connected to VDD until this VDD voltage reaches the UVLO (ON) threshold to turn on the WT7181R and further to deliver the gate drive signal. It will enable the auxiliary winding of the transformer to provide supply current. A hysteresis is built in to prevent the shutdown from the voltage dip during startup. Besides, recommended that the VDD capacitor C_{VDD} connected with VDD pin is in the range from 3.3 μ F to 4.7 μ F.

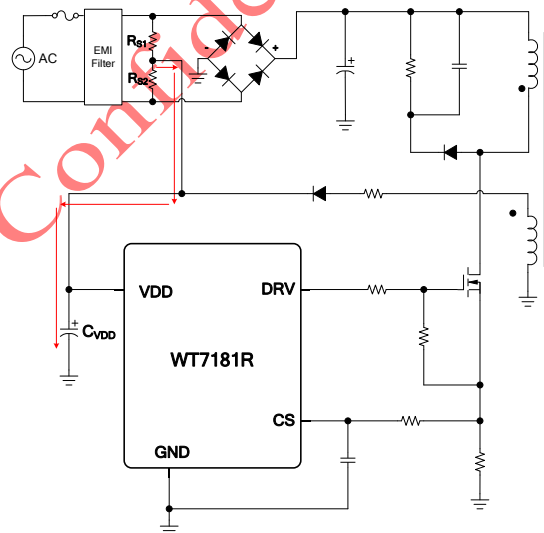

Fig. 5.1

5.2 Multi-Mode Operation for High Efficiency

The WT7181R is a high performance multi-mode (CCM/Valley Switching) Flyback PWM controller. The controller could operate in CCM and DCM with valley switching. As the load decreases, the controller enters green mode with valley switching. At zero load or very light load conditions ($V_{COMP} < \text{Burst mode voltage}$), the DRV pin of the WT7181R will be disabled immediately under such condition, enhancing power saving. The WT7181R helps to improve the overall efficiency and optimize the product performance. The burst mode will be disabled once the VDD voltage is smaller than the voltage level of the VDD maintain mode. VDD maintain mode function is used to prevent the output from re-starting when load changes. So never let the system operate on the VDD maintain mode at no load.

5.3 Open Loop Protection (OLP)

The WT7181R has an open loop protection function. An internal circuit detects the V_{COMP} level, when the V_{COMP} is larger than an OLP threshold level and continues over OLP delay time, the protection will be activated and then turn off the DRV output to stop the switching of power circuit.

5.4 Gate Clamp/Soft Driving

Driver output is clamped by an internal clamping circuit to prevent from undesired over-voltage gate signals to reduce the current consumption of the controller. The WT7181R also has soft driving function to minimize EMI.

5.5 DC Brown In/Out, Output OVP and UVP on VS Pin

The WT7181R provides the dc brown in/out, OVP and UVP multi-protection by using VS pin, two resistors, as shown in Fig. 5.2. These multi-protection functions are realized through time-division technology as shown in the Fig. 5.3. When DRV on, the auxiliary winding voltage is negative and VS pin is clamped close to 0V by internal circuit. The clamping current is proportional to the input voltage. When the clamping current is smaller than $275\mu\text{A}$ for longer than 64ms, the brown out protection is triggered. The brown in threshold clamping current is $300\mu\text{A}$. The equation of clamping current, IVS, is decreased as:

$$IVS \cong \frac{V_{in} \times \frac{N_{aux}}{N_p}}{R1}$$

$$R1 \cong \frac{V_{in(BNOIN)} \times \frac{N_{aux}}{N_p}}{300\mu\text{A}}$$

Where N_{aux} is the turns of VDD winding, N_p is the turns of primary winding.

When DRV off, WT7181R samples the auxiliary winding voltage via the divided resistors after a blanking time. The auxiliary winding voltage is reflected to secondary winding and therefore the voltage on the VS pin is proportional to the output voltage. The sampling voltage level, VS1, is used for OVP and UVP. If VS1 exceeds the 3.5V, the VS OVP circuit switches the power MOSFET off. If VS1 declines below 0.5V for over the 25ms, the UVP protection will be activated to turn off the DRV and protect the circuit from damage due to output short condition. The UVP will be disabled when IC enter the burst mode operation. The equation of VS1 is shown as below:

$$VS1 = V_{aux} \times \frac{R2}{R1 + R2} \cong V_{out} \times \frac{N_{aux}}{N_s} \times \frac{R2}{R1 + R2}$$

$$R2 \cong \frac{R1}{\frac{V_{out_OVP}}{3.5} \times \frac{N_{aux}}{N_s} - 1}$$

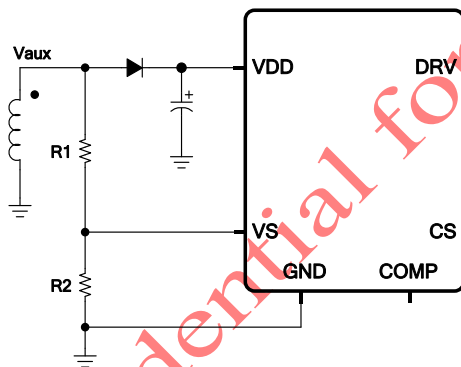

Fig. 5.2

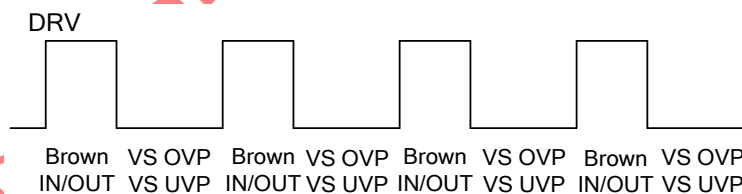

Fig. 5.3

5.6 Adjustable Over Current Line Compensation

To compensate over current protection under different input voltage, an offset voltage is added to the CS signal by an internal current source, IOCP and an external resistor, Rcs, in series between the sense resistor, Rsense, and the CS pin, as shown in Fig. 5.4. Different values of resistors in series with the CS pin may adjust the amount of compensation. The value of IOCP depends on the clamping current, IVS, of VS pin when the MOSFET is turned on. The clamping current is proportional to the input voltage.

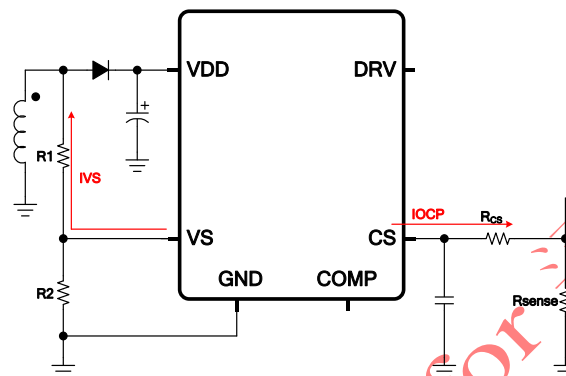

Fig. 5.4

5.7 Adaptive Green Mode Control

By using the green-mode control, the switching frequency can be reduced under the light load condition. This feature helps to improve the efficiency at light load. The system stability is different for wide range VOUT range application. The WT7181R would adjust green mode curve automatically to ensure the system stability for different VOUT operation.

5.8 CS Pin Short Protection

The WT7181R also provides CS pin short protection to protect system. When CS pin is short to GND or the CS signal is not detected, DRV will be turned off after a delay time and system will be shutdown. It is recommended that the ratio of the input voltage, the current sense resistor and the transformer must be limited by the following equation:

$$\frac{V_{in} \times R_{sense}}{L_p} > 25000$$

Where V_{in} is the input voltage, R_{sense} is the current sense resistor, L_p is the primary magnetizing inductance of the transformer. By the way, the CCM operation will be disabled in the CS short protection to reduce the voltage stress on the power MOSFET.

6. Electrical Characteristics

6.1 Absolute Maximum Ratings

Parameter	Min.	Max.	Units
VDD to GND	-0.3	72	V
DRV to GND	-0.3	Internal clamp	V
VS, COMP, CS,	-0.3	6.5	V
Junction Temperature		150	°C
Lead Temperature (Soldering, 10 sec.)		260	°C
Storage Temperature Range	-65	150	°C
CDM ESD		1	kV
HBM ESD		2.5	kV

NOTE: Maximum ratings applied to the device are individual stress limit value. Stresses above those listed may cause permanent damage and reliability may be affected.

6.2 Recommended Operating Parameters

Parameter	Symbol	Condition	Min.	Typ.	Max.	Units
V _{DD} Capacitor	C _{VDD}		3.3		4.7	μF
VDD Startup Resistor (AC Full Wave)	R _{S1} , R _{S2}		1.5		2.7	MΩ
COMP Pin Capacitor	C _{COMP}		1		10	nF
Operating Junction Temperature	T _J		-40		125	°C
Operating Ambient Temperature	T _A		-40		105	°C

Notes:

- Not to exceed the maximum junction temperature of the IC, this relates to the operating power of the IC and the thermal resistance of the IC-package as above.
- The small signal components should be placed to IC pin as possible.
- It's essential to connect VDD pin with a SMD ceramic capacitor (0.1μF~1.0μF) to filter out the undesired switching noise for stable operation. This capacitor should be placed close to IC pin as possible.

6.3 Thermal Resistance

Package	Parameter		Min.	Typ.	Max.	Units
SOT-26	θ_{JA}	Thermal Resistance (Junction to Air)		175		°C /W
	θ_{JMAX}	Maximum Junction Temperature		150		°C

6.4 Version Table

	WT7181R
VDD OVP	Auto
VS OVP	Auto
OLP	Auto
VS UVP	Auto
Output Rectifier Short Protection	Auto
CS Pin Short Protection	Auto

6.5 Electrical Characteristics

(VDD=15V, T_A=25°C, unless otherwise specified)

Parameter	Symbol	Condition	Min.	Typ.	Max.	Units
Supply Voltage (VDD PIN)						
VDD Turn-on Threshold	VDD_ON		15.2	16	16.8	V
VDD Turn-off Threshold	VDD_OFF		7	7.5	8	V
Startup Current	IDD_ST	VDD=V _{DD_ON} -0.2V		1.5	2	μA
Operating Current	IVDD_0	COMP=0V		450		μA
Operating Current	IVDD_3	DRV=1nF, COMP=3V, VS=2V		1.6		mA
VDD Maintain Mode Level	VDD_Main	(Note1)		8.5		V
VDD OVP	VDD_OVP			68		V
VDD OVP De_bounce Time				4		cycle
Protection Current_Auto	IPROT_A			620		μA

Parameter	Symbol	Condition	Min.	Typ.	Max.	Units
Loop Compensation (COMP PIN)						
COMP Open Level	V _{COMP_OPEN}		5	5.3	5.6	V
Open Loop Trip Threshold	VOLP		4.2	4.4	4.6	V
COMP Short Current	ICOMP_0V			200		μA
AV For CS/COMP		RA/RB, (Note1)		3		
Burst ON Threshold	Burst_ON			1.0		V
Burst Hys.	Burst_Hys			0.1		V
Open Loop Delay Time	TOLP	after start-up		80		ms

Parameter	Symbol	Condition	Min.	Typ.	Max.	Units
Internal Oscillator						
CCM Switching Frequency	FS_CCM	V _{COMP} =3V		65		kHz
CCM Jitter Range	FJITTER	V _{COMP} =3V		±5.2		kHz
Green Mode Frequency	FGREEN			28		kHz
Maximum Duty	DMAX	V _{COMP} =3V, (Note1)		75		%

Parameter	Symbol	Condition	Min.	Typ.	Max.	Units
Current Sense (CS PIN)						
CS OFF Threshold	VCS_OFF1	VS>0.7	0.64	0.66	0.68	V
Output Rectifier Short Protection		(Note1)		1.1		V
Leading Edge Blanking	TLEB	(Note1)		350		ns
Soft Start	TSS1	(Note1)		5		ms
Slope Compensation		0% to 75% (Note1)		300		mV

Parameter	Symbol	Condition	Min.	Typ.	Max.	Units
MOSFET Driver (DRV PIN)						
DRV High Level	VOH	RL=1 kΩ	9.5		VCC	V
DRV Low Level	VOL	I _o =20mA	0		1	V
DRV Clamp Level	VOC			11		V

Parameter	Symbol	Condition	Min.	Typ.	Max.	Units
Valley Switching (VS PIN)						
VS OVP Threshold	VS_OVP			3.5		V

Parameter	Symbol	Condition	Min.	Typ.	Max.	Units
VS_UVP Detection	VS_UVP			0.5		V
Brown IN Protection Current	IBNOH			300		μA
Brown OUT Protection Current	IBNOL			275		μA

Parameter	Symbol	Condition	Min.	Typ.	Max.	Units
Internal Thermal Shutdown						
Thermal shutdown temperature	T_{SD_L}	(Note1)		150		°C
Thermal shutdown hysteresis	T_{SD_H}	(Note1)		10		°C

Note 1. Guaranteed by design.

Weltrend Confidential for 通盛 ONLY

7. Simplified Application Circuit

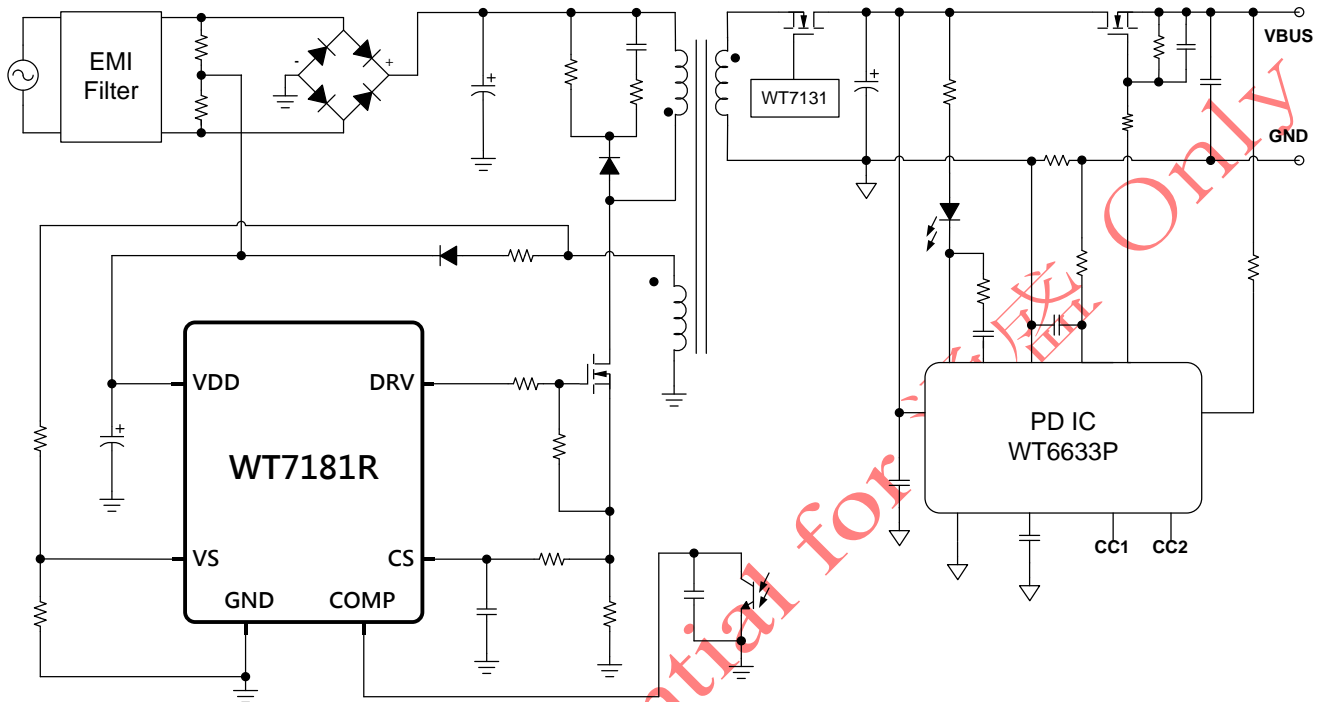

8. Ordering Information

Package Type	Part Number	Order Number	Top Marking	Tapping (EA/Reel)
SOT-26	WT7181R	WT7181R-TG06	A81R	3000

Example

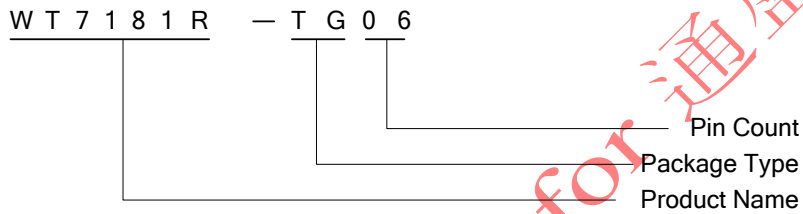

Top Marking

6-pin SOT Top Marking

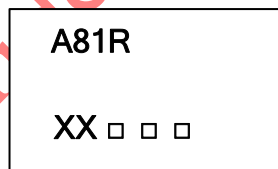

X: Production Tracking Code

□: Date Code

9. Package Information

9.1 Package Dimensions

Small Outline Transistor

SOT-26

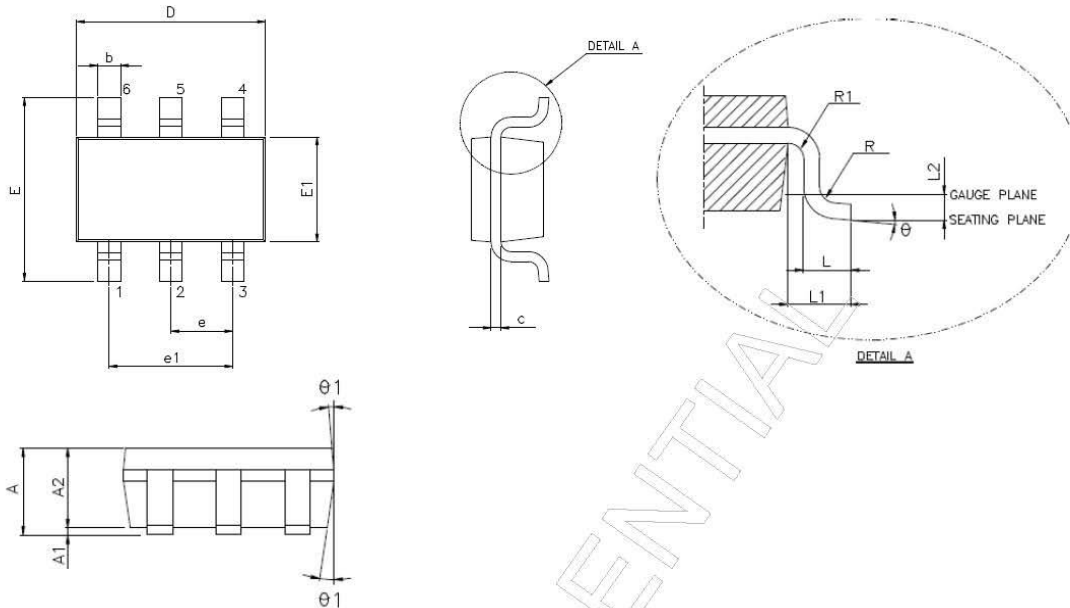

SYMBOLS	MIN	NOR	MAX
A	-	-	1.45
A1	0.00	-	0.15
A2	0.90	1.15	1.30
b	0.30	-	0.50
c	0.08	-	0.22
D	2.90 BSC		
E	2.80 BSC		
E1	1.60 BSC		
e	0.95 BSC		
e1	1.90 BSC		
L	0.30	0.45	0.60
L1	0.60 REF		
L2	0.25 BSC		
R	0.10	-	-
R1	0.10	-	0.25
θ°	0	4	8
θ1°	5	10	15

NOTES:

1. JEDEC outline : MO-178 AB

PREPARE	Cynthia	DATE: 2012/7/25
CHECK	Lawrence	DATE: 2012/7/25
APPROVE	Eric	DATE: 2012/7/25

UNIT: mm

10. Revision History

Version	History	Date
0.1	Initial issue	May 2020
0.2	Update Chapter 2, 5 & 6	September 2020

Weltrend Confidential for 通盛 Only