



偉詮電子股份有限公司  
**Weltrend Semiconductor, Inc.**

---

# **WT7518 / WT7518L / WT7518D**

## **PC POWER SUPPLY SUPERVISOR**

### **Data Sheet**

**REV. 2.10**

**November 26, 2002**

**The information in this document is subject to change without notice.  
©Weltrend Semiconductor, Inc. All Rights Reserved.**

---

新竹市科學工業園區工業東九路24號2樓  
2F, No. 24, Industry E. 9<sup>th</sup> RD., Science-Based Industrial Park, Hsin-Chu, Taiwan  
TEL:886-3-5780241 FAX:886-3-5794278.5770419  
Email:support@weltrend.com.tw



# WT7518 / WT7518L / WT7518D

Rev. 2.10

## GENERAL DESCRIPTION

The WT7518 series provides four or two protection circuits for over current detector (OCD), fault voltage level output and external delay control signal glitches for 14pins package.

The current detector level setting by ISn and RI pin.

## FEATURES

- The Over Current Detector (OCD) monitors IS1~IS4 input current sense.
- Fault protection (FPOB) are Open Drain Output, and latch for 141/143/145/147, un-latch for 140/142/144/146.
- 75 ms time delay for OCD.
- 38 ms for PSONB input signal De-bounce.
- Adjustable internal signal De-glitches by DELAY pin only for 14pins package.
- Under voltage lockout with hysteresis

## PIN ASSIGNMENT AND PACKAGE TYPE

### Pin assignment

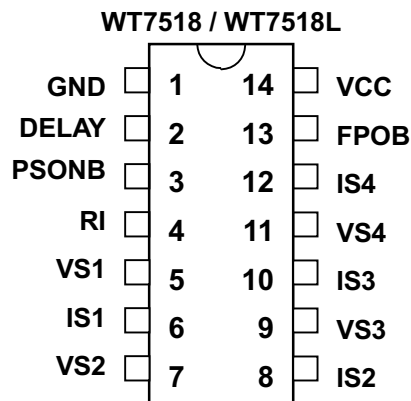

Package type	14-Pin Plastic DIP	14-Pin Plastic SOP
<b>ORDERING</b>	WT7518-N140WT	WT7518-S140WT
	WT7518-N141WT	WT7518-S141WT
	WT7518-N142WT	WT7518-S142WT
	WT7518-N143WT	WT7518-S143WT
	WT7518-N144WT	WT7518-S144WT
	WT7518-N145WT	WT7518-S145WT
	WT7518-N146WT	WT7518-S146WT
	WT7518-N147WT	WT7518-S147WT
	WT7518L-N140WT	WT7518L-S140WT
	WT7518L-N143WT	WT7518L-S143WT
	WT7518L-N144WT	WT7518L-S144WT
	WT7518L-N147WT	WT7518L-S147WT

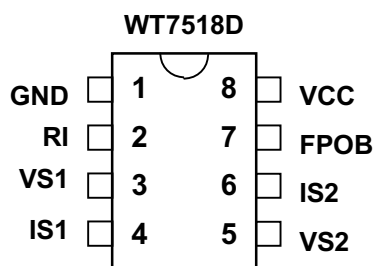

Package type	8-Pin Plastic DIP	8-Pin Plastic SOP
<b>ORDERING</b>	WT7518D-N080WT	WT7518D-S080WT



# WT7518 / WT7518L / WT7518D

Rev. 2.10

## PIN DESCRIPTION

Pin Name	TYPE	Description
GND	P	Ground
DELAY	IO	Adjust OCD de-glitch time by connect CAP. to ground
PSONB	I	On/Off switch input
RI	I	Current sense adjust input
VS1	I	1 <sup>st</sup> over current protection sense input
IS1	I	1 <sup>st</sup> over current protection sense input
VS2	I	2 <sup>nd</sup> over current protection sense input
IS2	I	2 <sup>nd</sup> over current protection sense input
VS3	I	3 <sup>rd</sup> over current protection sense input
IS3	I	3 <sup>rd</sup> over current protection sense input
VS4	I	4 <sup>th</sup> over current protection sense input
IS4	I	4 <sup>th</sup> over current protection sense input
FPOB	O	Fault protection output pin, open drain output
VCC	P	Power supply

## FUNCTION DESCRIPTION

ORDERING		UVLO	LATCH	FPL power on state
WT7518	N140/S140	4.5V/3.3V	un-latch	High
	N141/S141	10V/8V	latch	High
	N142/S142	10V/8V	un-latch	High
	N143/S143	4.5V/3.3V	latch	High
	N144/S144	4.5V/3.3V	un-latch	Low
	N145/S145	10V/8V	latch	Low
	N146/S146	10V/8V	un-latch	Low
	N147/S147	4.5V/3.3V	latch	Low
WT7518L	N140/S140	4.5V/3.3V	un-latch	High
	N143/S143	4.5V/3.3V	latch	High
	N144/S144	4.5V/3.3V	un-latch	Low
	N147/S147	4.5V/3.3V	latch	Low
WT7518D	N080/S080	10V/8V	un-latch	Low

## ABSOLUTE MAXIMUM RATINGS

Parameter		Min.	Max.	Unit
Supply voltage, VCC	WT7518, WT7518D	-0.3	16	V
	WT7518L	-0.3	7	V
Input voltage	PSONB	-0.3	7	V
	VS1, VS2, VS3, VS4	-0.3	VCC+0.3	V
	IS1, IS2, IS3, IS4	-0.3	VCC+0.3	V
Output voltage	FPOB	-0.3	VCC+0.3	V
Operating temperature		-40	125	°C
Storage temperature		-55	150	°C

\*Note: Stresses above those listed may cause permanent damage to the devices



## RECOMMENDED OPERATING CONDITIONS

Parameter	Conditions	Min.	Typ.	Max.	Unit
Supply voltage, VCC	WT7518, WT7518D		12	15	V
	WT7518L		5	7	V
Input voltage	PSONB			7	V
	VS1, VS2, VS3, VS4			VCC	V
	IS1, IS2, IS3, IS4			VCC	V
Output voltage	FPOB			VCC	V
Output sink current	FPOB			30	mA
VCC rising time		1			ms
Output current for RI	RI	10		65	uA

## ELECTRICAL CHARACTERISTICS, at Ta=25°C and V<sub>CC</sub>=5V

### PSONB

Parameter	Condition	Min.	Typ.	Max.	Unit
Input pull-up current	PSONB= 0V		150		uA
High-level input voltage		2.2			V
Low-level input voltage				0.6	V

### UNDER VOLTAGE LOCKOUT

Parameter	Condition	Min.	Typ.	Max.	Unit
Start voltage	140/143/144/147		4.5		V
	141/142/145/146/080		10		V
Min. operating voltage after turn on	140/143/144/147		3.3		V
	141/142/145/146/080		8		V

### TOTAL DEVICE

Parameter	Condition	Min.	Typ.	Max.	Unit
I <sub>CC</sub> Supply current	PSONB= 5V			1	mA
I <sub>LEAKAGE</sub> Leakage current (FPOB)	V(FPOB) = 5V		5		uA
V <sub>OL</sub> Low level output voltage (FPOB)	I <sub>sink</sub> =10mA		0.3		V
	I <sub>sink</sub> =30mA		0.7		

### SWITCHING CHARACTERISTICS, V<sub>CC</sub>=5V

Parameter	Condition	Min.	Typ.	Max.	Unit
t <sub>db1</sub> De-bounce time (PSONB)		32	38	61	ms
t <sub>db2</sub> De-bounce time (PSONB)		32	38	61	ms
t <sub>g1</sub> De-glitch time for OCD state active	WT7518, WT7518L DELAY=47pF, note1	64	80	96	us
	WT7518D	120	150	180	us
t <sub>g2</sub> De-glitch time for OCD state release	WT7518, WT7518L DELAY=47pF, note1	128	160	192	us
	WT7518D	240	300	360	us
t <sub>delay3</sub> Internal OCD delay time	after FPOB go low	65	75	122	ms

note1 : Please refer to Fig.1 for the relation of OCD De-glitch time and delay cap.

## BLOCK DIAGRAM

140/142 ( without latch and FPL power on state "high" )

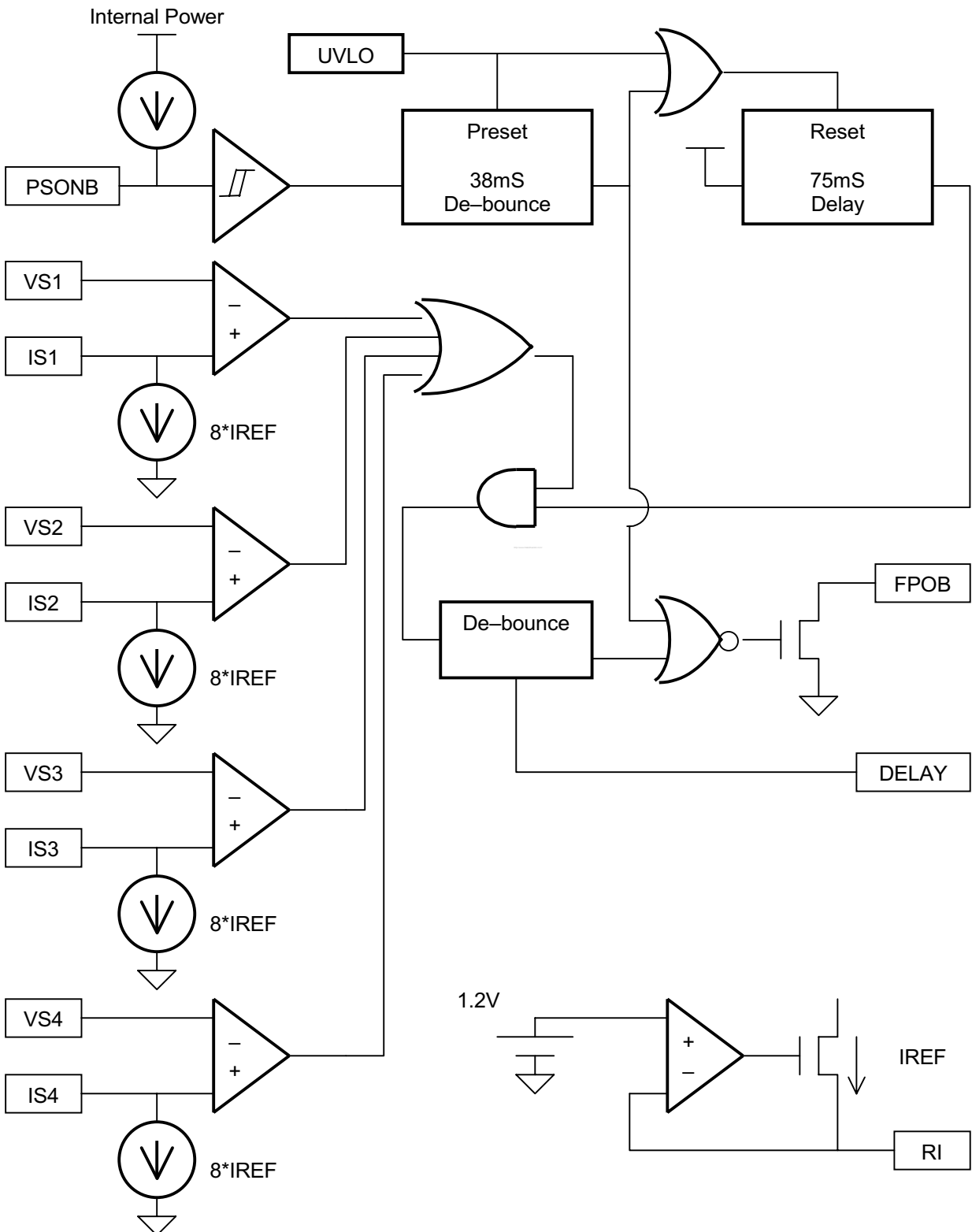

## BLOCK DIAGRAM

141/143 ( with latch and FPL power on state "high" )

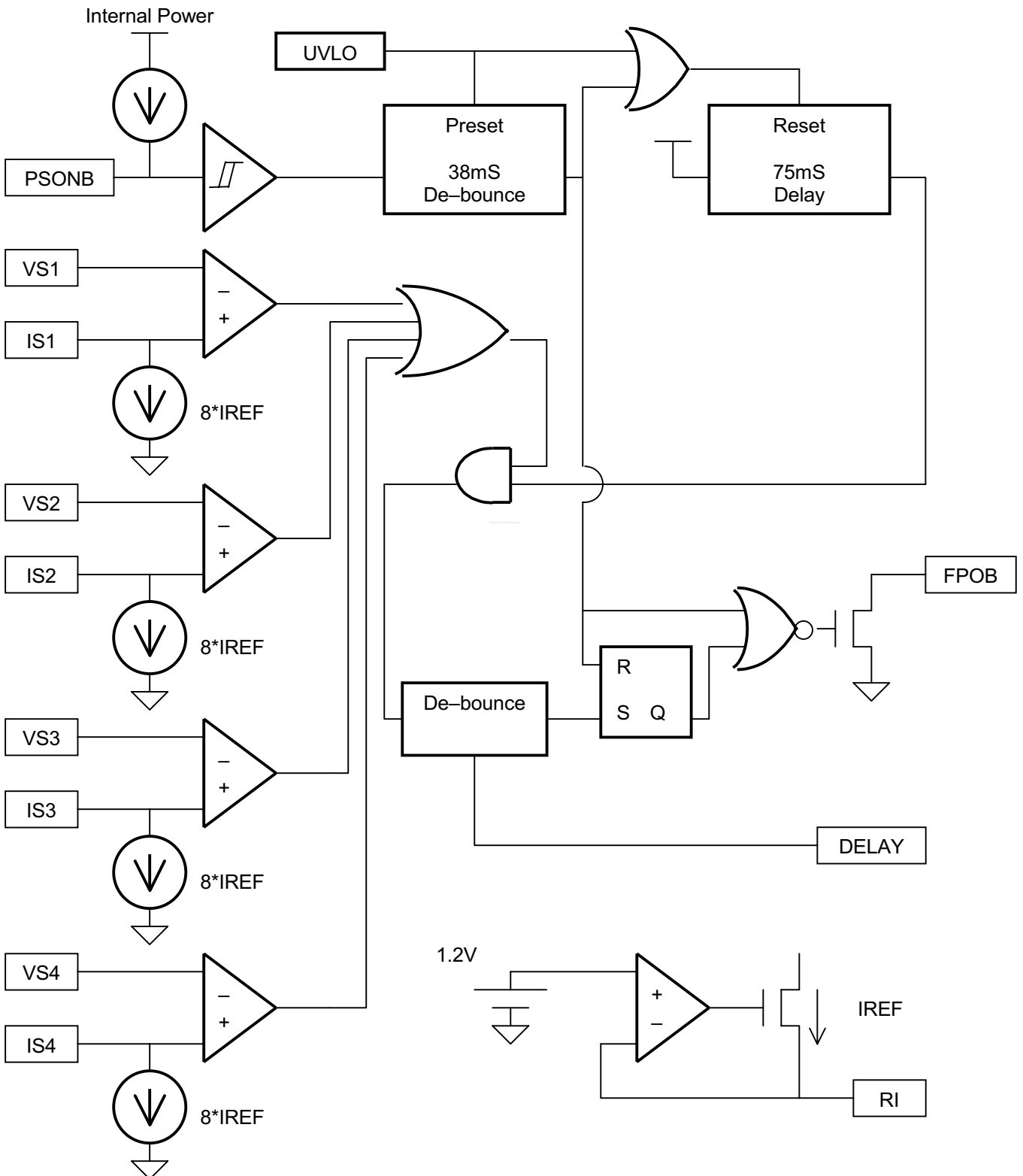

## BLOCK DIAGRAM

144/146 ( without latch and FPL power on state "low" )

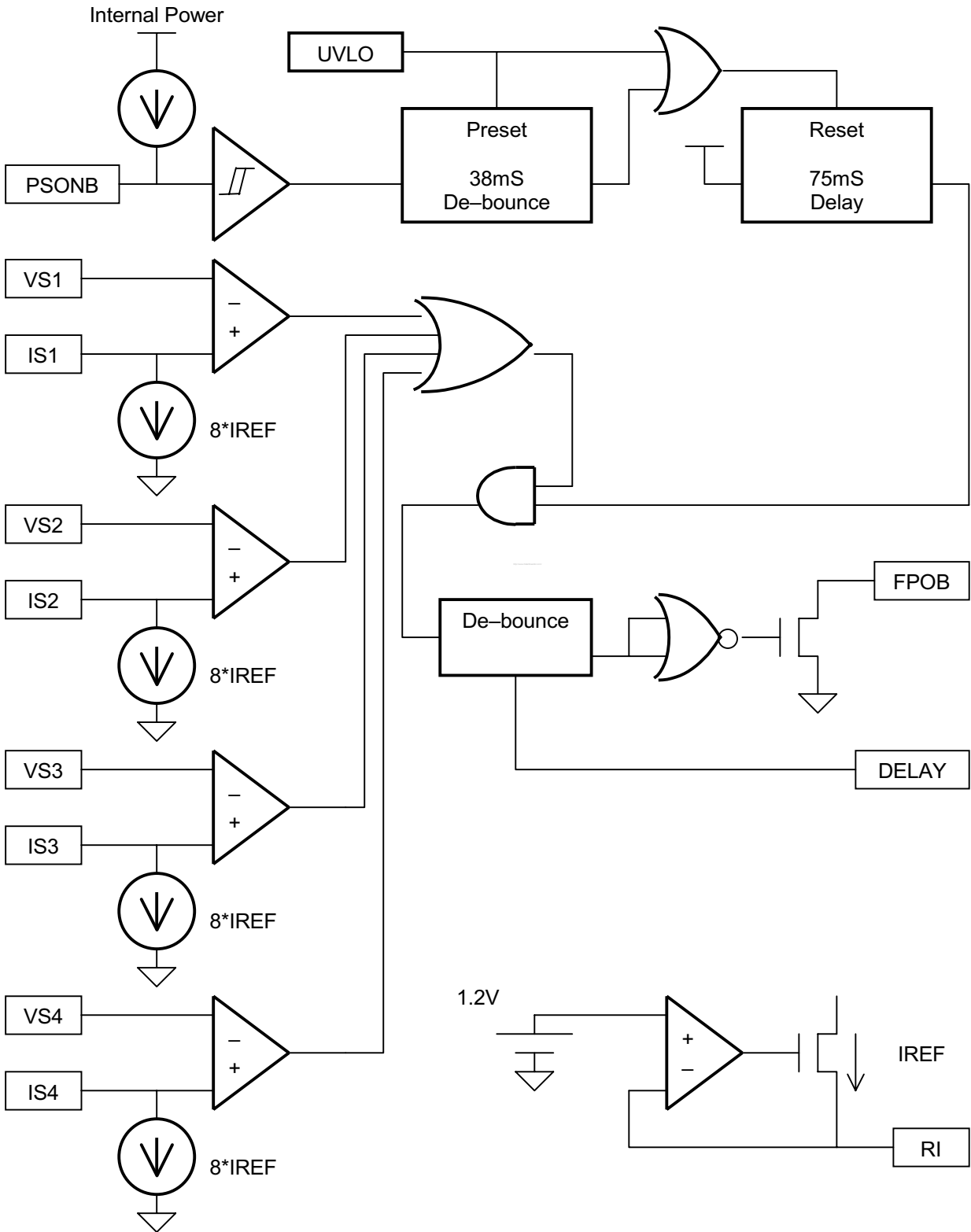

## BLOCK DIAGRAM

145/147 ( with latch and FPL power on state "low" )

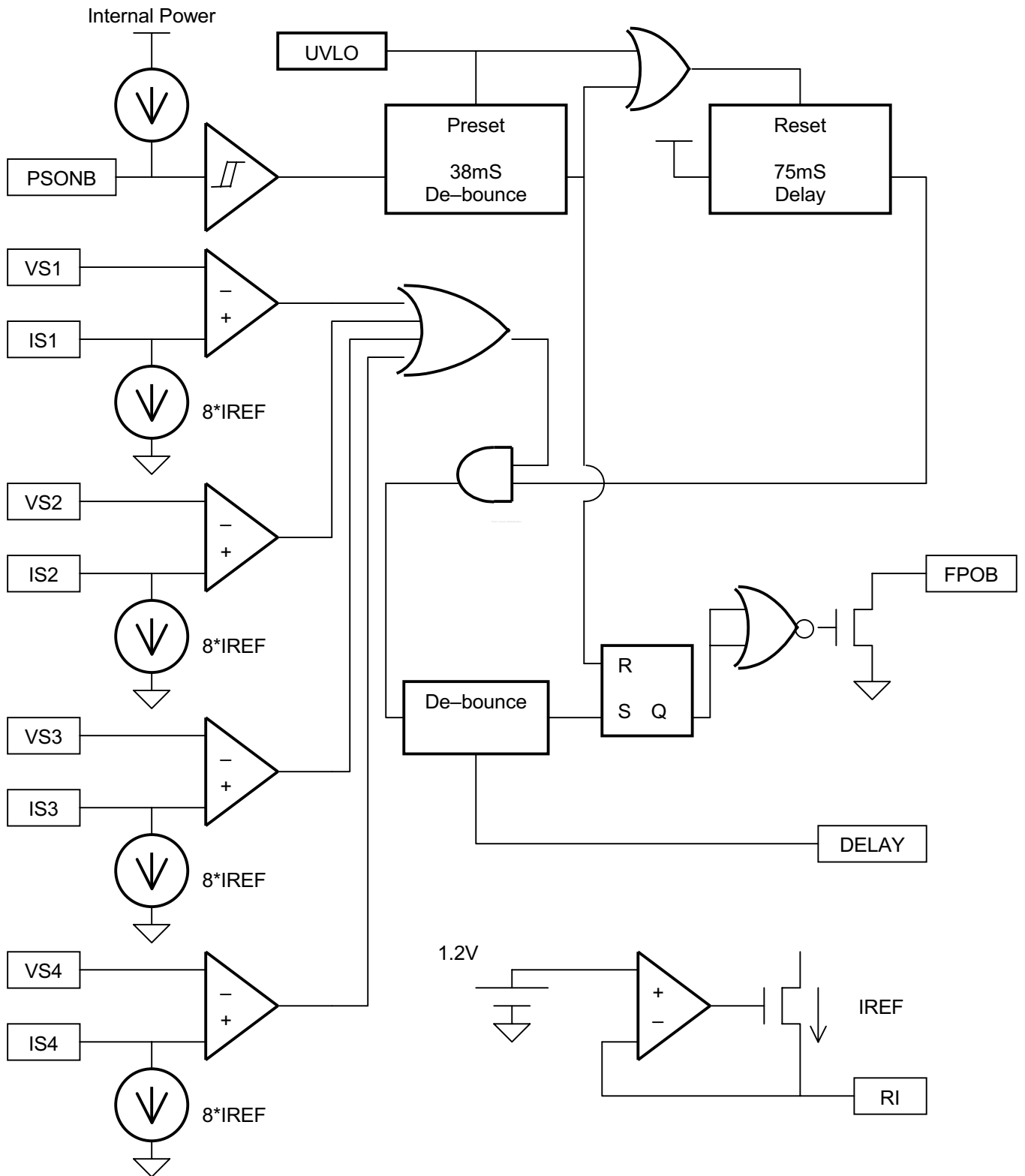



## BLOCK DIAGRAM

080 ( without latch and FPL power on state "low")

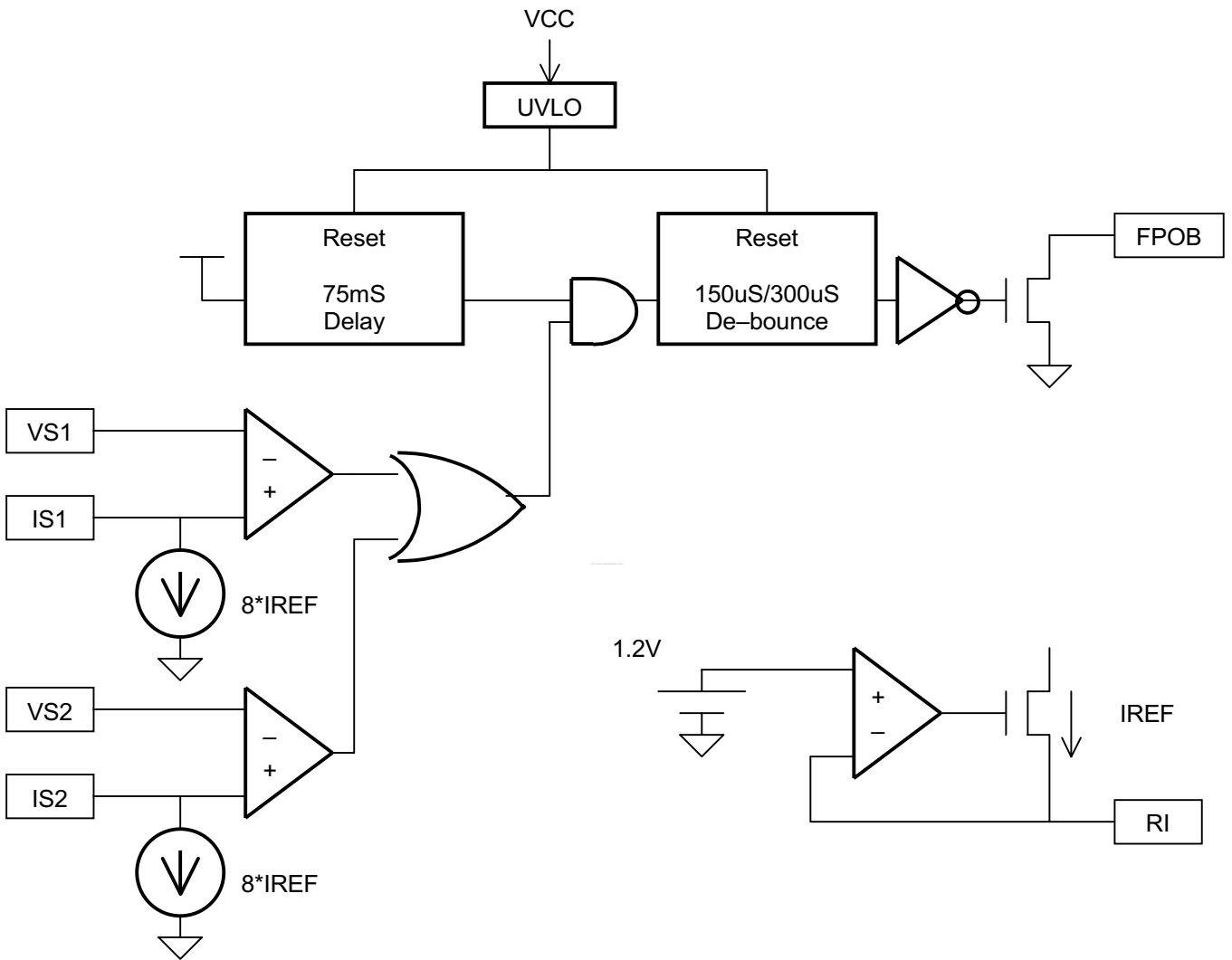

## APPLICATION CIRCUIT

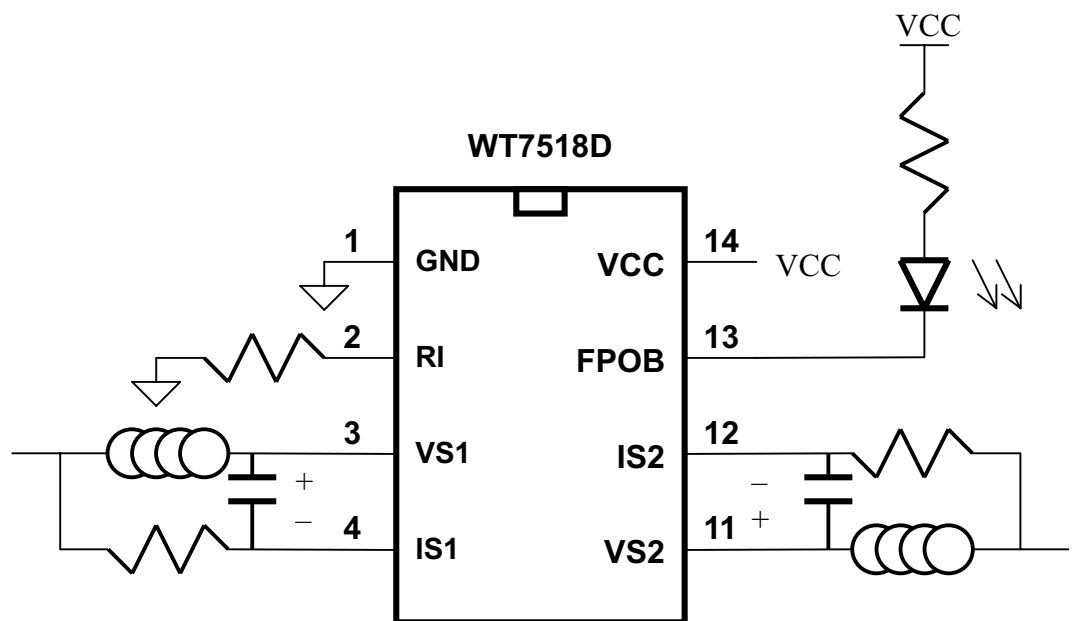
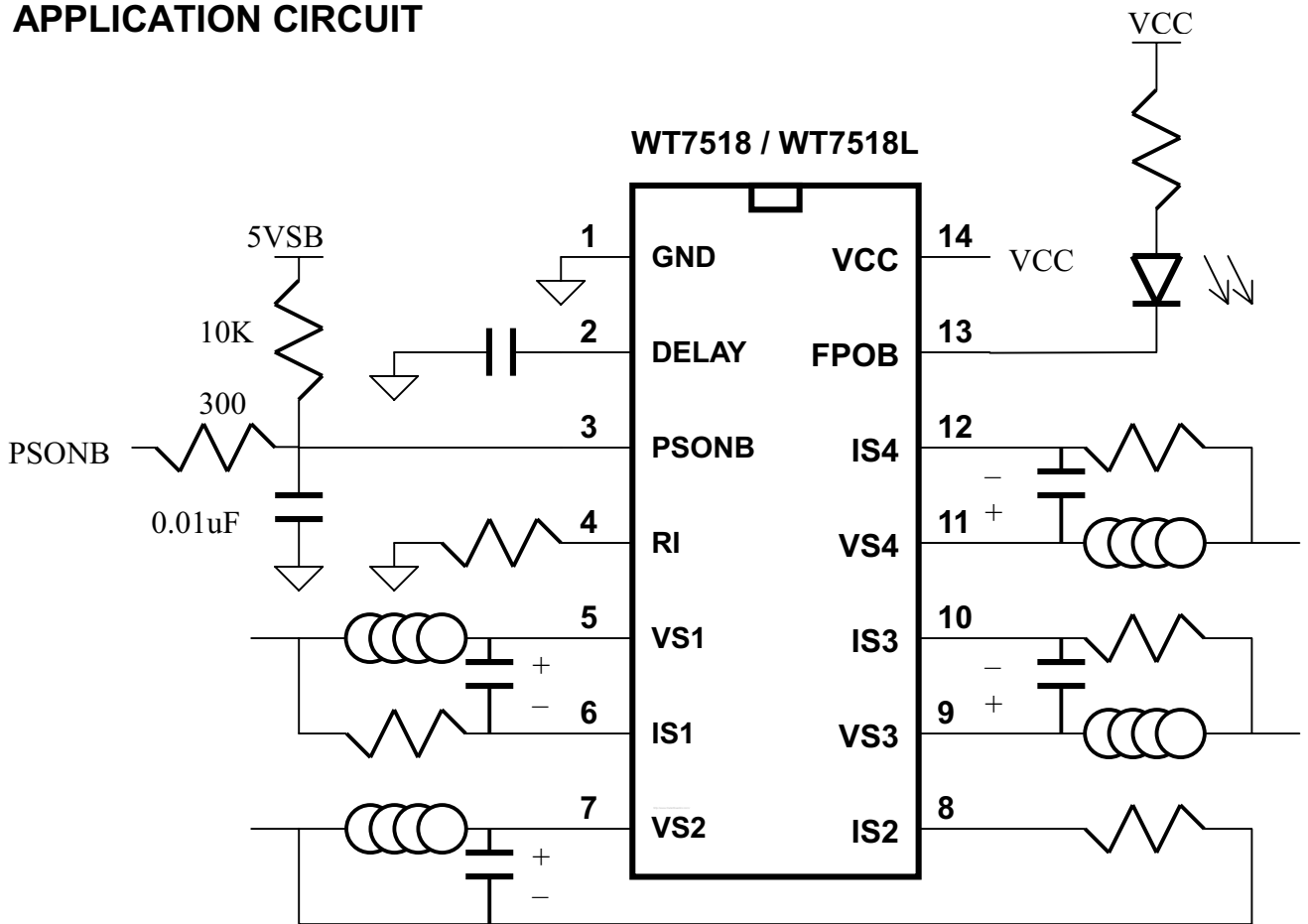

**APPLICATION NOTE**

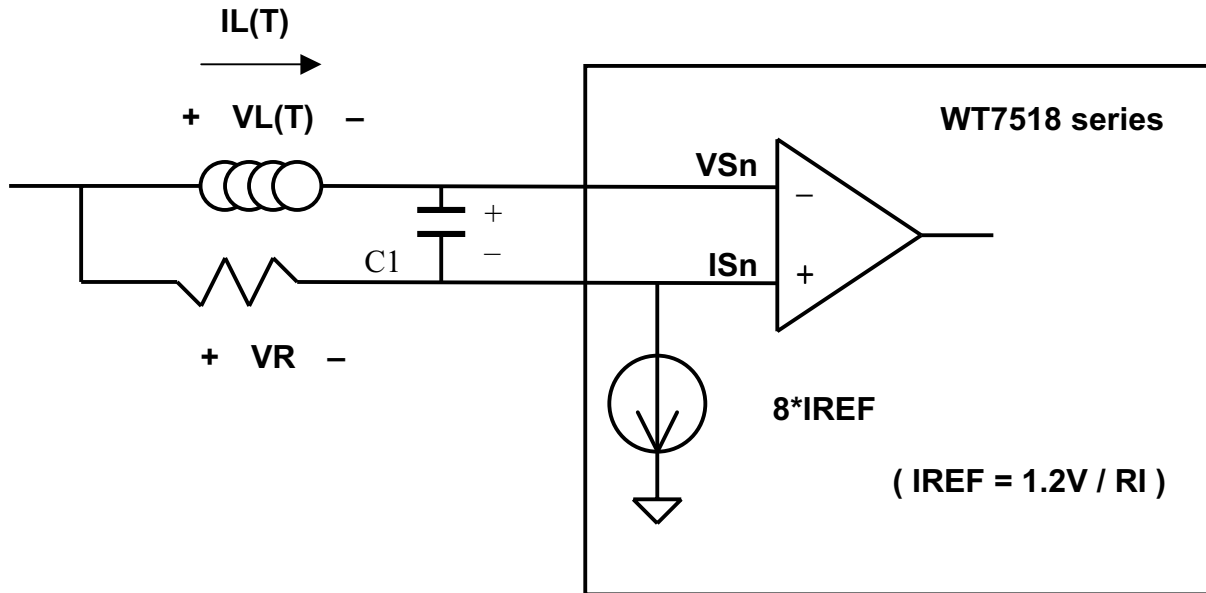

When the current cross inductor raised immediately, inductor voltage raised. And when inductor voltage exceeded resistor voltage, the OCP active.

We can setup OCP point by the following equation

$$V_L(T) = V_R$$

$$L * [ d I_L(T) / dT ] = ( 8 * 1.2 / R_I ) * R$$

$$d I_L(T) / dT = ( 8 * 1.2 / R_I ) * R / L \quad \dots(1)$$

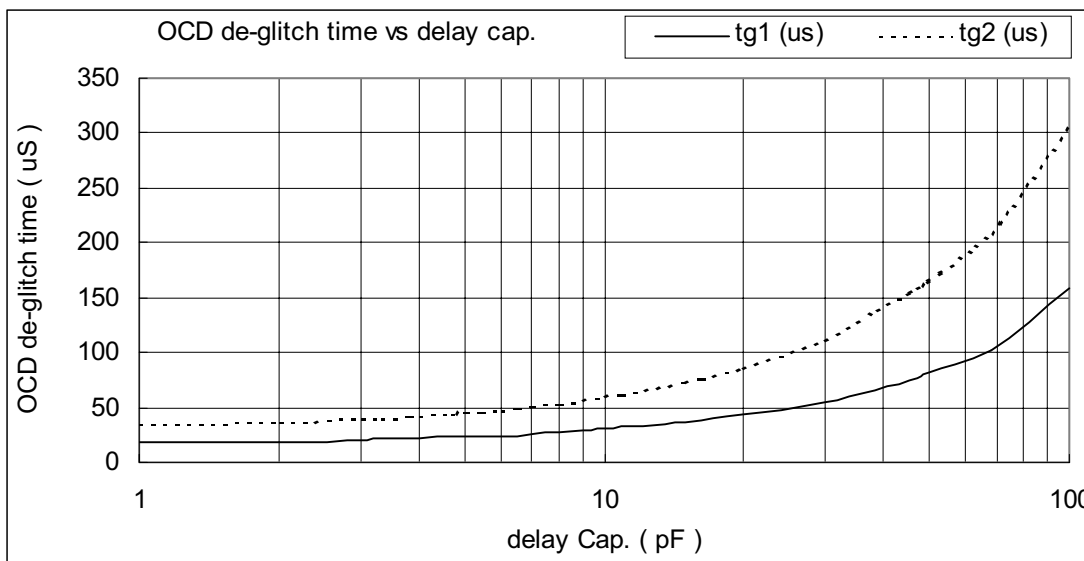
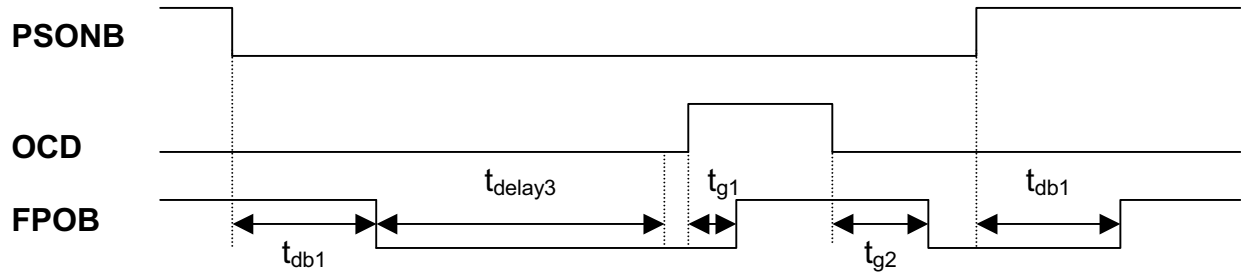

Fig.1 OCD de-glitch time vs delay cap.

## APPLICATION TIMMING

For 140/142 – FPOB without lath and FPL power on state “high”



For 141/143 – FPOB with lath and FPL power on state “high”

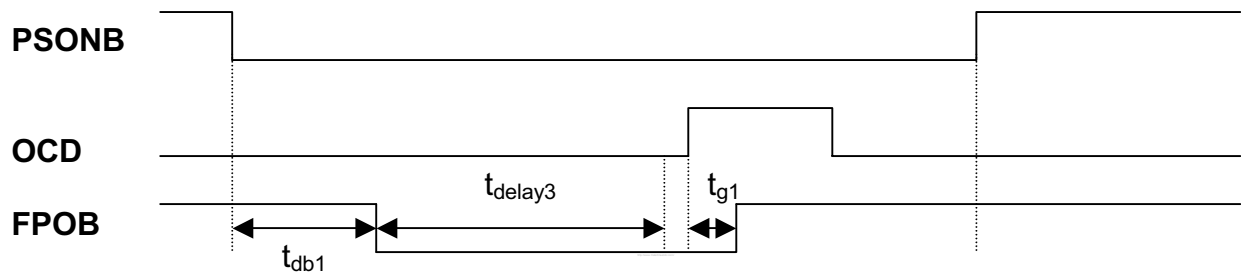

For 144/146 – FPOB without lath and FPL power on state “low”

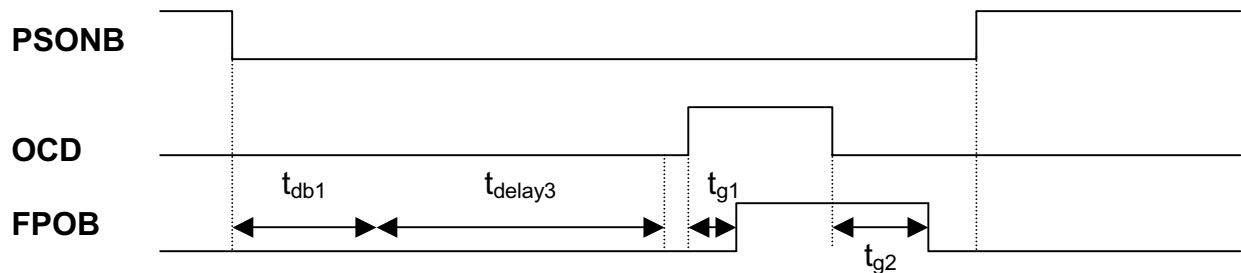

For 145/147 – FPOB with lath and FPL power on state “low”

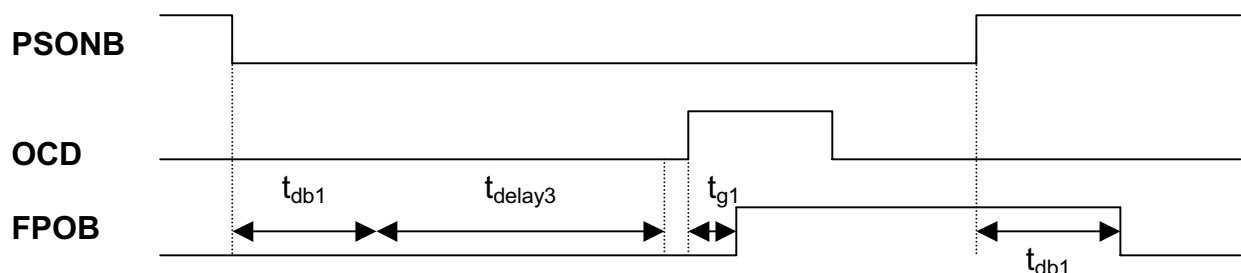



For 080 – FPOB without lath and FPL power on state “low”

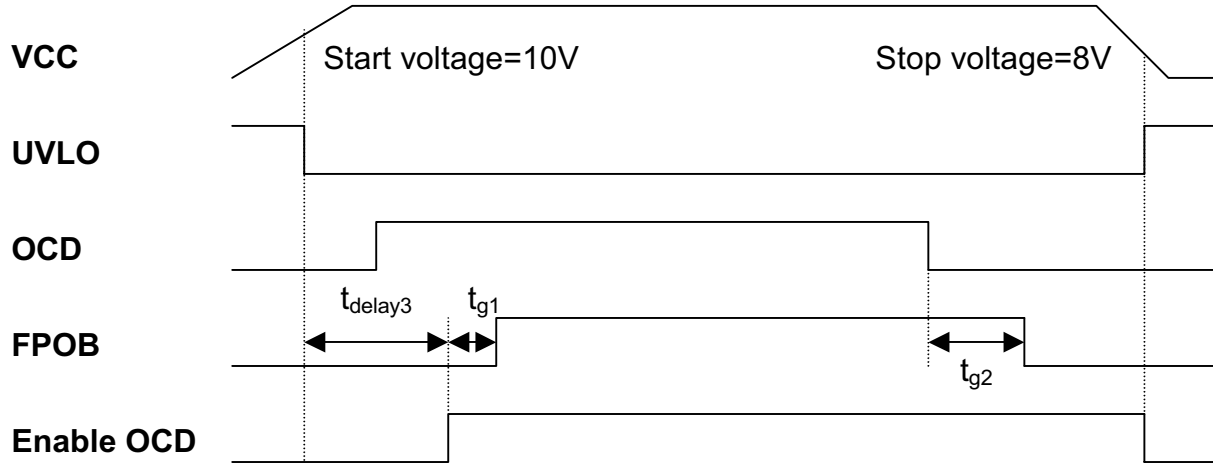

## MECHANICAL INFORMATION

### PLASTIC DUAL-IN-LINE PACKAGE

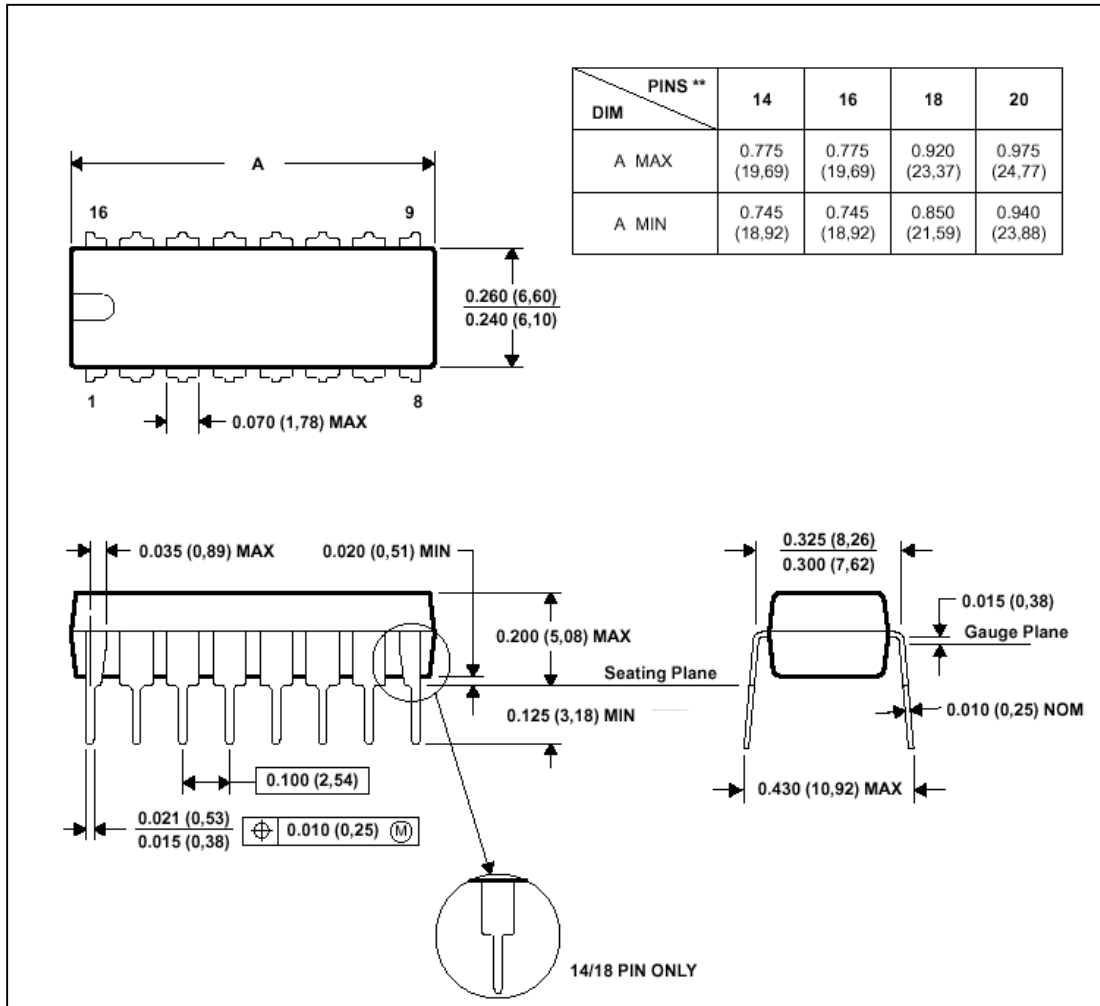

NOTE 1 : All linear dimensions are in inches ( millimeters ) .

NOTE 2 : This drawing is subject to change without notice.

NOTE 3 : Falls within JEDEC MS-001

## PLASTIC DUAL-IN-LINE PACKAGE

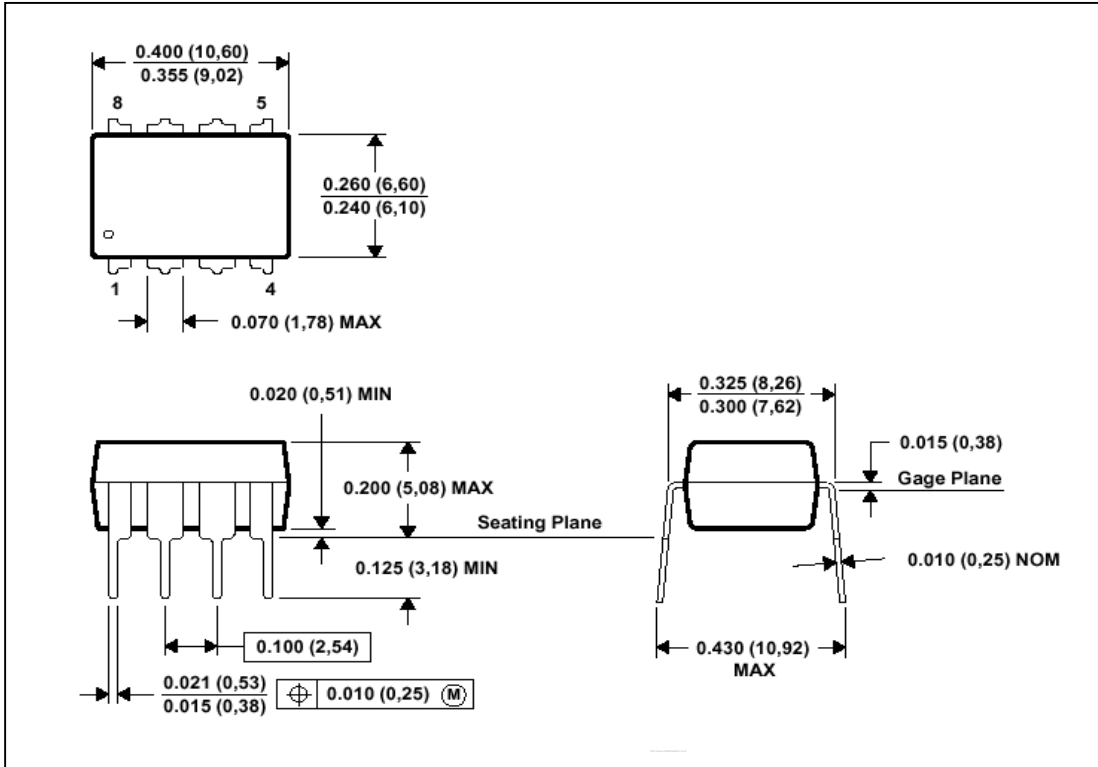

NOTE 1 : All linear dimensions are in inches ( millimeters ) .

NOTE 2 : This drawing is subject to change without notice.

NOTE 3 : Falls within JEDEC MS-001

## PLASTIC SMALL-OUTLINE PACKAGE

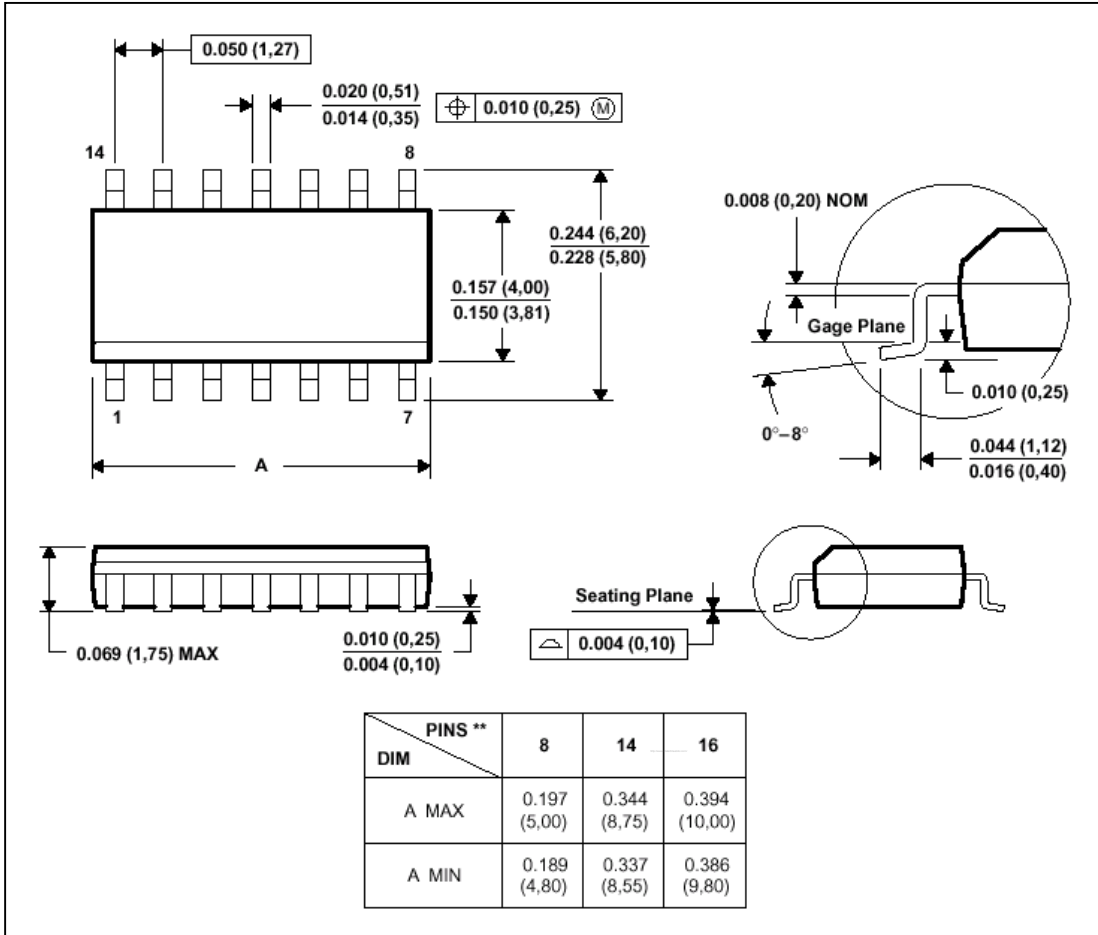

NOTE 1 : All linear dimensions are in inches ( millimeters ) .

NOTE 2 : This drawing is subject to change without notice.

NOTE 3 : Falls within JEDEC MS-012