



WTC6312ML

WTC6312ML Inductive touch key chip of twelve-channel electric capacitance

Fast Browsing

Number of keys	4-12 keys
Key response mode	Single key response and multi-key combination (SHIFT) mode can be selected
Technical principle	Capacitive to digital conversion technology
Dimension of key sense element	Minimum 3mm ×3mm, maximum 30mm ×30mm, to be determined according to actual demand and panel thickness
Spacing of key sense element	Single key mode, Minimum spacing 0.5mm, to be determined according to actual demand
Shape of key sense element	Arbitrary polygon, rotundity or ellipse, either panel with hole in the middle or hollow panel (optional)
Material of key sense element	PCB copper coil, sheet metal, flat-top cylinder spring, conductive rubber, conductive ink, ITO layer of conductive glass, etc.
Requirements for PCB	Single-sided PCB and double-sided PCB
Panel material	Insulating materials, such as organic glass, ordinary glass, tempered glass, plastic, wood timber, paper, ceramics and stone
Panel thickness	0 – 20 mm
Adjustment method of key sensitivity	Key sensitivity can be adjusted by changing value of base capacitance CSEL.
Effective touch response time	Less than 150 ms
Water resistance	Watering or spraying water on the panel will not cause malfunction of keys; when flooded or with water accumulation, no abnormal response occurs by touching the panel.
RFI resistance	Effectively suppress RFI (radio frequency interference) caused when GSM cell phone is used to make a call or answer a call next to the panel or a talk proceeds next to the panel over high-power walkie-talkie.
Operating voltage range	2.2V-5.5V
Operating temperature range	–40°C—+85°C
Data transmission interface	Slave mode of serial interface (SPI)
Storage temperature range	–50°C—+125C
Chip sealing mode	SSOP24(150MIL)



Table of Contents

1. Product Introduction.....	4
1.1. Overview.....	4
1.2. Working mechanism.....	4
1.3. Sensitivity adjustment mode.....	4
1.4. Adapt to different thickness panels.....	4
1.5. Chip Package Type.....	4
2. Technical Features and Parameters.....	4
2.1. Technical Features.....	4
2.1.1. Simple Peripheral Circuits, and A Few Peripheral Components.....	4
2.1.2. Debugging-free Production and Excellent Long-time Working Stability.....	5
2.1.3. The user can use the compact keyboard of smaller spacing.....	5
2.1.4. Excellent Water Resistance.....	5
2.1.5. Excellent Electromagnetic Immunity.....	5
2.1.6. Unique Line Length Self-correction Function.....	5
2.2. Technical Parameters.....	5
3. Typical Application.....	6
4. Definitions of WTC6312ML Pins.....	6
5. Working Condition and Output Display.....	7
6. The SPI interface of WTC6312ML.....	8
6.1. SPI sequence diagram.....	8
6.2. SPI port work status of WTC6312ML.....	8
6.3. PI signal line function.....	8
6.4. Data transmission rules of SPI.....	8
6.5. SDI signal processing.....	9
7. Notices for using the SPI interface.....	9
7.1. The two read intervals are not less than 4ms.....	9
7.2. SCS and SDI, SDO are not allowed to be suspended at any time.....	9
7.3. SDI can be fixed to connect VCC.....	9
7.4. SCS is not allowed to be fixed grounding.....	9
8. WTC6312ML work mode selection.....	9
8.1. The characteristics of the multi-key combination (SHIFT) working mode.....	9
8.2. The characteristics of the single-key working mode.....	10
9. Multi-key combination (SHIFT) mode.....	10
9.1. The peripheral circuit of the multi-key combination (SHIFT) mode and the matters needing attention..	10
9.2. The data format and transport protocol of the multi-key combination (SHIFT) mode.....	11
10. Single key work mode.....	11
10.1. The peripheral circuit of the single key work and the matters needing attention.....	11
10.2. The data format of the single key working mode and transport protocol.....	12
11. Sensitivity Setting.....	12



WTC6312ML

- 11.1. The adjustment mode of the sensitivity..... 12
- 11.2. Benchmark capacitance CSEL material, range and precision requirements..... 13
- 11.3 The software fine adjustment of the Sensitivity..... 13
 - 11.3.1 The software fine adjustment series of the sensitivity..... 13
 - 11.3.2. Factory setting sensitivity initial value of chip..... 13
- 11.4 The effect of the size of the sense element on the sensitivity..... 13
- 12. WTC6312ML Power Supply..... 13
 - 12.1 It is recommended to use DC Voltage Stabilizer for power supply..... 13
 - 12.2. Placement of Voltage Stabilizer Component..... 14
 - 12.3. Grounding..... 14
 - 12.4 Valuing of the capacitor C2..... 14
 - 12.5. Precautions for High Noise Condition..... 14
- 13. The work, dormancy and awakening of WTC6312ML..... 14
 - 13.1 The dormancy of WTC6312ML..... 15
 - 13.2 The awakening of WTC6312ML..... 15
 - 13.2.1. Mechanical awakening..... 15
 - 13.2.2. The awakening of the touch key..... 15
 - 13.3. Power Filter..... 15
 - 13.4. Use of +5V Power Supply of the Host..... 15
- 14. WTC6312ML used capacitive sensors (sense element)..... 16
 - 14.1.The material and shape of the capacitive sensors..... 16
 - 14.2. The area of the sense element..... 16
 - 14.3. The bonding between the sensor plate and the panel..... 16
 - 14.4. Eliminate the bonding gap..... 17
- 15. Processing of Vacant Sensor Channel..... 17
- 16. Package Dimension Drawing of WTC6312ML..... 17



WTC6312ML Inductive touch key chip of twelve-channel electric capacitance Specification (V1.4)

1. Product Introduction

1.1. Overview

WTC6312ML series touch sensing IC is an integrated circuit designed to achieve human touch interface. It can replace the mechanical light touch key to realize waterproof and dustproof, seal isolation, with strong and artistic operation interface. The very low standby power consumption of it can meet the requirements of reliability and low power consumption of the protection equipment of the safe box password lock and other battery power supply. A WTC6312ML can achieve 4 to 12 independent keys. The user can use it flexibly according to the needs.

1.2. Working mechanism

WTC6312ML uses the change of capacitance on the 16 bit high precision of CDC (digital capacitance transducer) IC detection sense element (capacitance sensor) to identify the touch action of the human finger. The data of CDC output is processing by the embedded RISC CPU with efficient and reliable algorithms. The user can read the key state of the touch key through the SPI interface.

1.3. Sensitivity adjustment mode

It is only needed to adjust one capacitor Csel that can change the sensitivity of all channels, with less peripheral component, and high production efficiency.

1.4. Adapt to different thickness panels

Through selecting the appropriate Csel capacitance value, appropriately adjusting the sense element can make WTC6312ML to adapt the insulation panel of the different thickness of 0-20mm.

1.5. Chip Package Type

WTC6312ML is packaged with standard 24PIN SSOP24A(150mil).

2. Technical Features and Parameters

2.1. Technical Features

2.1.1. Simple Peripheral Circuits, and A Few Peripheral Components

With independently designed special test circuit, self-calibration circuit and RISC processor integrated inside the IC, there are a few peripheral components.



2.1.2. Debugging-free Production and Excellent Long-time Working Stability

Calibration is not necessary for the system after the set value for capacitor Csel of sensitivity is determined. The system can automatically overcome the interference caused by electrostatic discharge, electromagnetic interference, temperature variation and accumulation of moisture and pollutants on the surface, and provide good precision and operation consistency in various environments, so the product can suffer long-distance transportation and be used in various environments. The unique compensation algorithm and high-strength anti-interference design can guarantee no occurrence of malfunction during long-time work of the product.

2.1.3. The user can use the compact keyboard of smaller spacing

The adjacent key suppression function can prevent the adjacent keys from the faulty action. That is when the same finger touches two or more than two keys, only the finger occupies the key which the area is largest that can make the response, and the key which the relatively small area is occupied by finger is suppressed and not making the response. If the finger occupies two or more than two keys at the same area, these keys do not make the response. The minimum clearance of the key can reach 0.5mm

2.1.4. Excellent Water Resistance

The special waterproof design is used for it. The keyboard not only can be splash proof, flood water proof, but also can be normal use after completely flooded, is different from the general induction at present which when the splashing water, flood water of key panel, it is easily getting false action and is unresponsive after waterlogging, or is occurring false action after pressing it by finger.

2.1.5. Excellent Electromagnetic Immunity

When applying to home apparatuses and ordinary application products, the user may get good immunity to radio frequency signals by using single-sided PCB, and easily resist the interference of most of radio frequency sources including GSM cell phone to the sensitive keys.

When applying to military and other special situations, it is suggested that double-sided PCB should be designed according to the layout requirements provided by us.

2.1.6. Unique Line Length Self-correction Function

It is common for the current similar products on the market that, the sensitivity largely differs according to the length of line from sensing key to IC pin. Our original line length self-correction technology can automatically correct such difference. The user can obtain almost uniform sensitivity for all keys of the whole sense element without complex adjustment.

2.2 Technical Parameters

WTC6312ML

Operating voltage: 2.2V<Vcc<5.5V
 Output voltage range: GND<Vout<Vcc
 Sensing thickness (insulating medium): 0-20mm
 Response time of effective touch: Less than 150ms
 Operating temperature: -40°C—+85°C
 Storage temperature: -50°C—+125°C

3. Typical Application

Be applicable to various kitchen apparatuses, audio and video devices, air conditioners, sanitary electrical apparatuses, lights and switches, security equipment, instruments, portable player, mobile phones, electronic toys and learning machines.

4. Definitions of WTC6312ML Pins

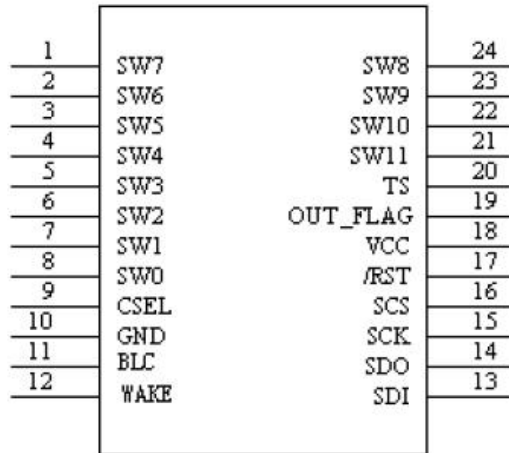

Figure 1: WTC6312ML pin configuration diagram

Table 1: The definitions of WTC6312ML pins

Pin No.	Pin Name	Usage	Function Description
1	SW7	I	Sense element of key 7
2	SW6	I	Sense element of key 6
3	SW5	I	Sense element of key 5
4	SW4	I	Sense element of key 4
5	SW3	I	Sense element of key 3
6	SW2	I	Sense element of key 2
7	SW1	I	Sense element of key 1
8	SW0	I	Sense element of key 0
9	CSEL	I	Capacitor interface for adjusting the sensitivity



WTC6312ML

10	GND	I	Power ground
11	BLC	O	The backlight control can also be used to indicate the working state of the chip. When it is low electrical level, it indicates that the chip is in the normal working condition, and when it is high electrical level, it indicates that the chip has entered into the dormant state. At this time, the working current of the chip can be reduced to below 10uA
12	WAKE	I	The external connection of the chip awakens the pin. After the chip enters the dormancy and when the foot has a change from high electrical level to low electrical level, it can immediately awaken the chip. (The interior of WAKE foot has about 30K of the upper pulling resistance).
13	SDI	I	Data input line of the chip SPI interface
14	SDO	O	The data output line of the chip SPI interface
15	SCK	I	The clock input line of the chip SPI interface
16	SCS	I	The chip selection enabled line of the Chip SPI interface
17	/RST	I	Chip reset pin
18	VCC	I	positive power supply output
19	OUT_FLAG	O	Key status indicator: when there is key pressed, it is the low level signal. And when all the keys are flicked, it restores to be high level
20	TS	I	When the selection foot of the work mode: connects VCC, the single key working mode is selected, and when it connects to GND, the multi-key combination (SHIFT) mode is selected.
21	SW8	I	Sense element of key 8
22	SW9	I	Sense element of key 9
23	SW10	I	Sense element of key 10
24	SW11	I	Sense element of key 11

5. Working Condition and Output Display

Instruction of the work state: After the chip firstly enters into the normal working mode, BLC outputs the low level, at this time, under the situation of the larger 3V power supply of the power consumption current, the output is low level, and the typical power consumption is 1mA. And when under the situation that the induction key is no any touch, the chip will automatically enter into the power saving mode after 10 seconds, and the BLC will output the low level, at this time, the typical power consumption of the power consumption current 3V power supply of the chip is reduced to 10uA

When the chip is working properly, there is effective touch on the key occurred which will enter into the timer of the power-saving mode to reset, and start 10 seconds timing again.

There are two ways to awaken the chip from the power-saving mode to enter into the normal working mode.

1: When in the power-saving mode, the level variation from high to low can be generated on the WAKE foot of the chip, which can be generated by a mechanical key or by the master MCU of the user

2: When in the power saving mode, touching a touch key keeping without releasing for a period of time (< 400mS) can awaken the chip into the normal working mode.

If touching several touch keys at the same time, it can shorten the holding time of the key needed by awakening chip.

WTC6312ML

Output instructions:

When the effective touch on the sense element occurred is detected, the foot of OUT_ FLAG of WTC6312ML within 150ms will output the level signal. The customer can use this signal to realize the key awakening function

Under the situation of the shift mode, only all fingers have left the touch key OUT_ FLAG, the foot can restore to the high level.

The user program can read the key value of the key through the SPI interface after detecting the out_flag foot as low level.

6. The SPI interface of WTC6312ML

6.1 SPI sequence diagram

The SPI time sequence diagram is shown in figure 4:

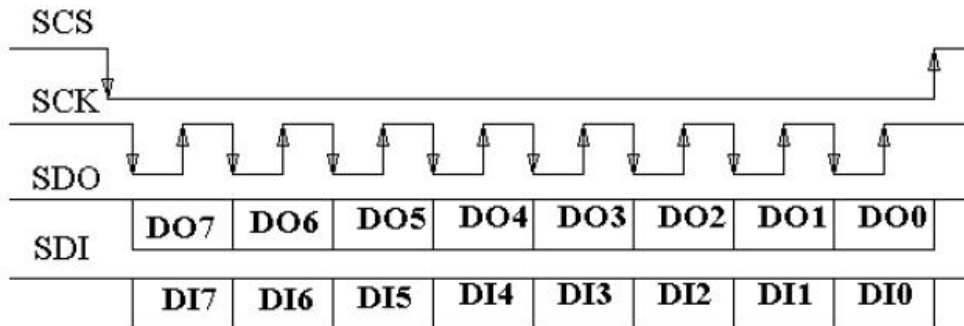

Figure 4: Sequence diagram of the SPI interface of WTC6312ML

6.2. SPI port work status of WTC6312ML

The working subordinate machine state of SPI port of WTC6312ML

6.3. PI signal line function

SCS is the enable signal of chip selection of SPI port, is set by the user MCU. The SPI port does not work when SCS = 1. SPI port function is opened when SCS = 0.

SCK is the clock signal of SPI port, generated by user MCU. The initial electrical level should be high.

SDO is the SPI data output signal of WTC6312ML, and the user MCU reads the status of SDO to obtain key data.

SDI is the SPI data input signal of WTC6312ML, and the user MCU can set the sensitivity of the touch key with software by setting SDI. Please be sure to set the SDI to be high level when not in use.

6.4. Data transmission rules of SPI

The data of SPI is transmitted beginning from the highest level.



6.5. SDI signal processing

If you do not use software to set touch sensitivity through setting SDI, please connect SDI to VCC. If SDI is needed to be used, SDI must be set to be high level before reading the SDO operation. Otherwise, the touch sensitivity may be wrong set to be 0.

7. Notices for using the SPI interface

7.1. The two read intervals are not less than 4ms

If the SPI interface of WTC6312ML is continuous read-write, it will cause the instability of the device working. The time of reading and writing twice should be more than 4ms.

7.2. SCS and SDI, SDO are not allowed to be suspended at any time

If there is no master control MCU of the SPI interface on the touchpad, then the pulling resistance must be added on the SCS and SDI and SDO of WTC6312ML, to ensure that the chip can steadily operate. SCS and SDI, SDO cannot be suspended at any time.

7.3. SDI can be fixed to connect VCC

If the sensitivity of WTC6312ML is not set by using the software, the pulling resistance must be added to SDI Or SDI must directly connect to fix the VCC to set the high.

7.4. SCS is not allowed to be fixed grounding

SCS is not allowed to be fixed grounding

8. WTC6312ML work mode selection

When the 20th foot (TS foot) of WTC6312ML is connected to GND, the chip enters into the multi-key combination (SHIFT) working mode.

When the 20th foot (TS foot) of WTC6312ML is connected to VCC, the chip enters into the single-key working mode.

8.1 The characteristics of the multi-key combination (SHIFT) working mode

Under the multi-key combination (SHIFT) working mode, if the user presses the multiple keys without release, then multiple keys can respond in turn. That is, after the user touches any of the keys, if the finger doesn't leave the sense element, and then the user touches the other keys, WTC6312ML will put the switch information of all the corresponding keys that are touched into the key data register of WTC6312ML. The user

WTC6312ML

can read the switch information of all the keys through the SPI interface. The system designer can design various key combination operation functions accordingly.

8.2 The characteristics of the single-key working mode

Under the single-key mode, only one key can be touched at a time. That is after the user touches any key, if the finger does not leave and touches other key, WTC6312ML will not respond. Until the finger leaves the sense element, other keys begin to respond to the touch of the user. The customer can use this mode to implement the function of “only one touch is allowed at a time”.

The introduction in Chapter 9 is the multi-key combination (SHIFT) mode of WTC6312ML and the introduction in chapter 10 is the single key mode of WTC6312ML. The user can choose to read according to the own usage requirements, and make thee design according to the corresponding requirements.

9. Multi-key combination (SHIFT) mode

9.1The peripheral circuit of the multi-key combination (SHIFT) mode and the matters needing attention

The peripheral circuit of WTC6312ML is very simple, and only needs a few resistors and capacitors. The key component is capacitor CSEL for adjusting the sensitivity and 1K resistance group for measuring the matched impedance of circuit. CSEL should use 10%-precision polyester capacitor, capacitor **made of NOP material paster** or capacitor **made of X7R material paster**. 1K resistance group can provide you with the best and most stable measurement effect, and **CSEL and matched resistance shall be placed as close as possible to IC at PCB layout.**

Figure 5 is the application circuit diagram of WTC6312ML work under the multicity combination of 12 keys (SHIFT) mode

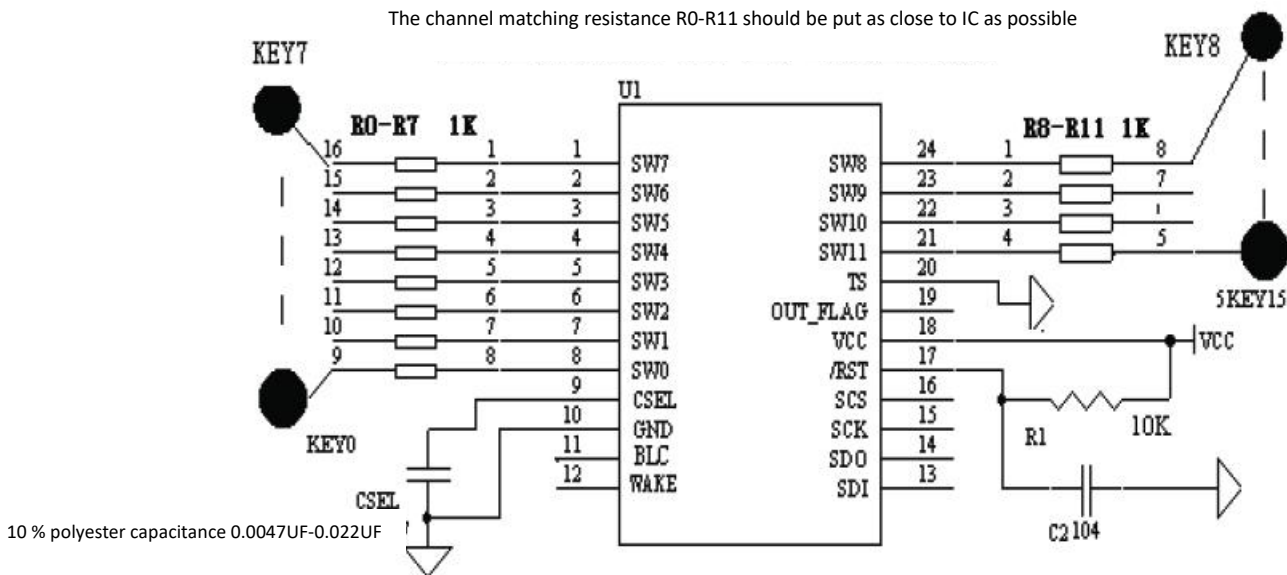



WTC6312ML

Figure 5: Application schematic diagram of WTC6312ML under multi-key combination (SHIFT) working mode

9.2 The data format and transport protocol of the multi-key combination (SHIFT) mode

Under the multi-key combination (SHIFT) working mode. When the user reads the full 12 touch key information from the SPI interface of WTC6312ML, the user needs read the SPI mouth twice.

After electrifying, the master control MCU reads SPI mouth for the first time, WTC6312ML will send the first frame data, and when reading SPI mouth WTC6312ML for second time, it will send out the second frame data. When reading SPI for the third time, it will get the first frame data, and when reading SPI for the fourth time, it will get the second frame data and 1-2-1-2-1-2 circulation on this.

The program of reading key value must have the function of the judgment of the frame header otherwise it will cause the data frame misaligned

When reading of the SPI mouth each time, please take more than 4ms of interval time.

The data format of the first data frame is

Bit7	SW5 key state. 1 indicates that SW5 is pressed and 0 indicates that SW5 is not touched or has been flicked
Bit6	SW4 key state. 1 indicates that SW4 is pressed and 0 indicates that SW4 is not touched or has been flicked
Bit5	SW3 key state. 1 indicates that SW3 is pressed and 0 indicates that SW3 is not touched or has been flicked
Bit4	SW2 key state. 1 indicates that SW2 is pressed and 0 indicates that SW2 is not touched or has been flicked
Bit3	SW1 key state. 1 indicates that SW1 is pressed and 0 indicates that SW1 is not touched or has been flicked
Bit2	SW0 key state. 1 indicates that SW0 is pressed and 0 indicates that SW0 is not touched or has been flicked
Bit1	The frame number indicates that the fixation is 0
Bit0	The frame number indicates that the first frame is 0

The data format of the second data frame is

Bit7	SW11 key state. 1 indicates that SW11 is pressed and 0 indicates that SW11 is not touched or has been flicked
Bit6	SW10 key state. 1 indicates that SW10 is pressed and 0 indicates that SW10 is not touched or has been flicked
Bit5	SW9 key state. 1 indicates that SW9 is pressed and 0 indicates that SW9 is not touched or has been flicked
Bit4	SW8 key state. 1 indicates that SW8 is pressed and 0 indicates that SW8 is not touched or has been flicked
Bit3	SW7 key state. 1 indicates that SW7 is pressed and 0 indicates that SW7 is not touched or has been flicked
Bit2	SW6 key state. 1 indicates that SW6 is pressed and 0 indicates that SW6 is not touched or has been flicked
Bit1	The frame number indicates that the fixation is 0
Bit0	The frame number indicates that the second frame is 1

10. Single key work mode

10.1 The peripheral circuit of the single key work and the matters needing attention

WTC6312ML

The peripheral circuit of WTC6312ML is very simple, and only needs a few resistors and capacitors. The key component is capacitor CSEL for adjusting the sensitivity and 1K resistance group for measuring the matched impedance of circuit. CSEL should use 10%-precision polyester capacitor, capacitor **made of NOP material paster** or capacitor **made of X7R material paster**. 1K resistance group can provide you with the best and most stable measurement effect, and **CSEL and matched resistance shall be placed as close as possible to IC at PCB layout.**

Figure 6 is the application circuit diagram of WTC6312ML working under the 12 keys single key working mode

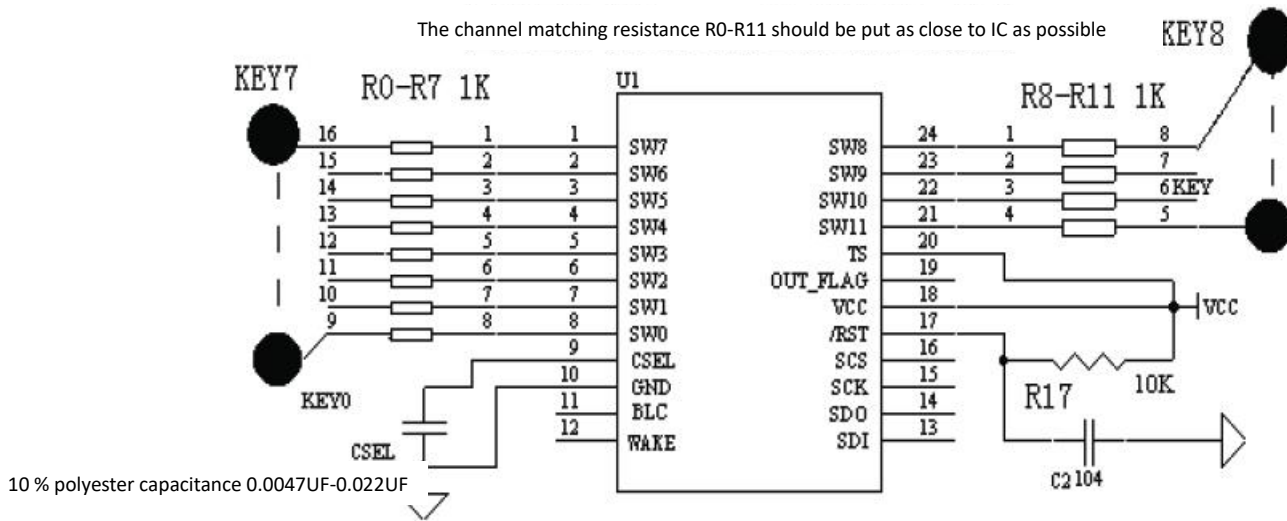

Figure 6: Application schematic diagram of WTC6312ML under the single key working mode

10.2 The data format of the single key working mode and transport protocol

The data format of the single bond work mode and transport protocol is relatively simple. The data obtained from the every read of master control MCU to the SPI interface is the key value of the touched key. If the data obtained is 0, it indicates that the sense element connected to the SW0 channel is touched by the user. If the data obtained is 11, it indicates that sense element connected to the SW11 channel is touched by the user, and the rest can be done in the same manner. When you read 0FFH, it indicates that there is no key touched or the touched key has been flipped.

11. Sensitivity Setting

11.1. The adjustment mode of the sensitivity

The sensitivity setting of WTC6312ML enables the user to use isolated media of various thicknesses to implement reliable and flexible touch function.



WTC6312ML

The sensitivity of WTC6312ML is set by the double setting of soft and hardware. The user can fix the SD to connect the high level, so the software sensitivity adjustment function is not used, and the Csel is just adjusted to realize the sensitivity setting, so that the master control MCU can save a I/O interface line, but also can reduce the software space of the master MCU.

11.2. Benchmark capacitance CSEL material, range and precision requirements

The user can select the appropriate capacitance Csel according to the own use case. The larger the separation medium is, the larger the Csel capacity is. It is generally recommended to choose the appropriate capacitance between 0.0047UF and 0.022UF from large to small.

It is recommends that it is best to use the A 5 % precision polyester capacitor with a small temperature coefficient for Csel. 10 percent accuracy of polyester capacitance can also be used. If needing use of patch capacitors, 10% or higher precision NPO material or X7R capacitance needs to be used.

11.3 The software fine adjustment of the Sensitivity

After determining the value of Csel, the software sensitivity setting can be used to make the fine adjustment, to ensure that it can achieve good results without having to make the refined adjustment to Csel. After the user MCU sets the sensitivity series through the SPI interface, WTC6312ML uses the new set sensitivity series to perform the work.

11.3.1 The software fine adjustment series of the sensitivity

WTC6312ML provides level 16 software sensitivity adjustment of 15~0. The higher the level is, the more sensitive the key is. If the data received by WTC6312ML is not within 15~0, then WTC6312ML will consider this data illegal, and will ignore this operation

11.3.2. Factory setting sensitivity initial value of chip

The factory setting sensitivity initial value of WTC6312ML is 10. The user also does not use the software sensitivity adjustment function and only uses the original factory setting and only makes the Csel adjustment.

11.4 The effect of the size of the sense element on the sensitivity

Increasing the area of sense element is benefit to improve the penetration ability of touch sensing.

12. WTC6312ML Power Supply

12.1 It is recommended to use DC Voltage Stabilizer for power supply

WTC6312ML measures small change in capacitance, so it is required that the power ripple and noise should be small and the external strong interference involved from power supply shall be avoided. Particularly

WTC6312ML

when it is applied to induction cooker and microwave oven, the external interference and voltage leap must be effectively isolated, and the power supply must have high stability. It is suggested that the voltage stabilizing circuit constituted by 78L05 as shown in the figure 6 should be adopted.

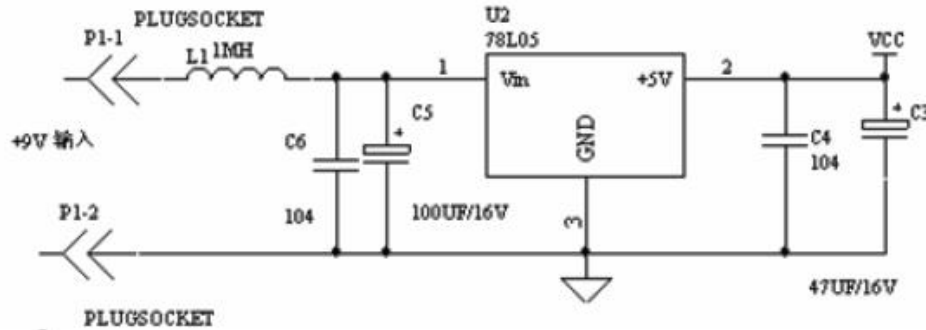

Figure 7: Voltage regulator circuit

12.2. Placement of Voltage Stabilizer Component

At PCB LAYOUT, such 78L05 power component must be close to WTC6312ML Vcc pin. 78L05 peripheral components and WTC6312ML must be placed on the same circuit board centrally, to put an end to the noises caused by overlong power connection line.

12.3. Grounding

The common ground of the components as shown in the figure shall be separately connected into an independent group and then it shall be connected to the common ground of the whole machine from one point of it. (Use one point of star shape to connect the ground)

12.4 Valuing of the capacitor C2

The C2 capacity affects the discharge time after power failure. Too large capacity requires a longer reset time. In the figure, it is the e recommended value, and the different applications can be flexibly adjusted.

12.5. Precautions for High Noise Condition

In case of application in a high-noise environment, up and down overlapped placement shall be avoided between high-voltage (220V), high-current, and high-frequency-operation main board and the touch circuit board. If such overlapped placement is unavoidable, try to keep far achannel from high-voltage, high-current components area or add shield on the main board.

13. The work, dormancy and awakening of WTC6312ML

After WTC6312ML is electrified, within 200ms, it enters into the normal working mode.

13.1 The dormancy of WTC6312ML

WTC6312ML has low power consumption mode. After the operation key is finished, it enters into hibernation mode at the set time, and when it is 3V, after the chip is dormant, the typical value of static current is less than 8uA.

13.2 The awakening of WTC6312ML

WTC6312ML has two awakening types coexisted

13.2.1. Mechanical awakening

Under the sleep mode, the mechanical key S1 is pressed, the chip is awakened and enters the working state

13.2.2. The awakening of the touch key

Under the sleep mode, touching any one or several keys, the chip is awakened, and enters the working mode

13.3. Power Filter

When typesetting in PCB, it is recommended to reserve the inductor L1 (1MH) welding disc, but the general and the non-special applications do not need this inductance. The users can also cancel it.

When inputting 78L05 power supply, it needs to pay attention to ripple size. Please don't make the trough of ripple wave lower than DC 9V.

13.4. Use of +5V Power Supply of the Host

If the user directly uses 5V power supply of the main engine, it needs adding the power supply filter circuit in the front of the power supply of the modules or sensing power chips as shown in the figure. The requirement for PCB layout is the same as the above circuit

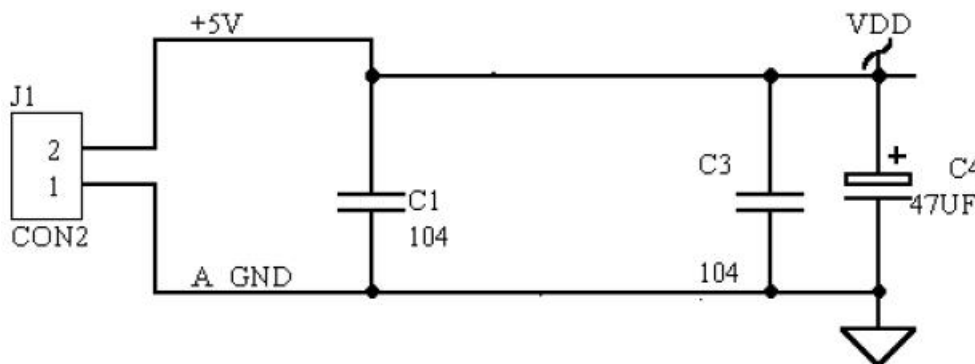

The analog and digital powers of circuit shall be connected separately to the ground in Y-connection method.

WTC6312ML

The capacitors shall be arranged in the sequence indicated in the schematic diagram and shall not be arranged arbitrarily.

Figure 8: Power Filter Circuit

Precautions:

The above circuit should connect the 104 capacitors and electrolytic capacitors of the filter circuit according to the order in the chart, and 104 capacitors should be in front of the electrolytic capacitance that can better suppresses the high frequency noise.

14. WTC6312ML used capacitive sensors (sense element)

14.1. The material and shape of the capacitive sensors

The capacitive sensors can be any type of conductor, but certain flat surface should be ensured. It is recommended to use a round metal sheet or other conductor with a diameter greater than 12mm. The commonly used sense elements are copper foil, spring, thin film line and ITO glass, etc. on the PCB plate

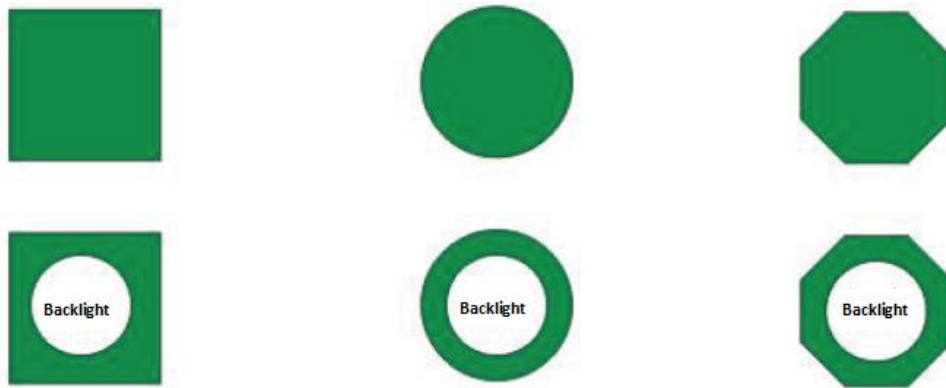

The key sense element can be solid or hollow rectangle, circle or polygon.

Figure 8: PCB Copper Foil sense element

14.2. The area of the sense element

The area of each sense element should be kept as same as possible to ensure the same sensitivity.

14.3. The bonding between the sensor plate and the panel

The capacitive sensor should be glued to glass and other insulating panels, or the elastic bonding is used for it

The common elastic connection methods are:

Use the sense element with spring

Use cylindrical conductive rubber to conduct elastic connection

WTC6312ML

Paste the sense element onto the panel with imported super double-sided glue, and the double-sided glue layer cannot be too thick.



Figure 10: Spring sense element

14.4. Eliminate the bonding gap

The bonding face of the sense element and the insulation panel must be flat, ensuring that there is bonding fit and no clearance between them.

15. Processing of Vacant Sensor Channel

WTC6312ML at least must use four touch keys, to ensure the steady operation of the chip. When it applies to the situation of less than 12 keys, SW11~SW0 will have the empty unused sensor input channel. The empty input channel only needs a simple suspending in midair, and the empty input channel cannot be added any pull-up or pull-down resistance.

If the user must use four or less sensitive keys, please be sure to contact us for the corresponding technical support.

16. Package Dimension Drawing of WTC6312ML

Symbol	Dimensions in mil		
	Min.	Nom.	Max.
A	228	—	244
B	150	—	157
C	8	—	12
C'	335	—	346
D	54	—	60
E	—	25	—
F	4	—	10
G	22	—	28
H	7	—	10
α	0°	—	8°

WTC6312ML

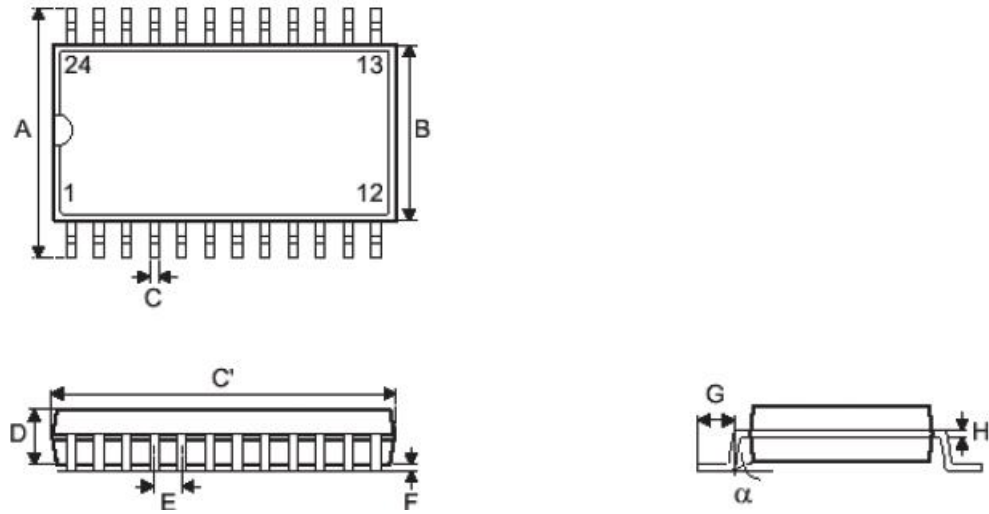

Figure 11: Package Dimension Drawing of WTC6312ML