



WTC7508DSI 8-Channel Capacitive-Sensing Touch Button Chip

Fast Browsing

Number of keys	3-8 keys
Technical principle	Capacitive to digital conversion technology
Key response mode	When it is set as IIC output, WTC7508DSI is the SHIFT mode, and when it is the multi-key touch, it is reflected in the order of operation. When it is set as BCD output, WTC7508DSI is the single key output mode, which can only operate one key one time.
Dimension of key sense element	Minimum 3mm ×3mm, maximum 30mm ×30mm, to be determined according to actual demand and panel thickness
Spacing of key sense element	Minimum spacing 0.5mm, to be determined according to actual demand, It can be used as the intensive keyboard.
Shape of key sense element	Arbitrary polygon, rotundity or ellipse, either panel with hole in the middle or hollow panel (optional)
Material of key sense element	PCB copper coil, sheet metal, flat-top cylinder spring, conductive rubber, conductive ink, ITO layer of conductive glass, etc.
Requirements for PCB	Single-sided PCB and double-sided PCB
Panel material	Insulating materials, such as organic glass, ordinary glass, tempered glass, plastic, wood timber, paper, ceramics and stone
Panel thickness	0 – 20 mm
Adjustment method of key sensitivity	Key sensitivity can be adjusted by changing value of base capacitance CSEL.
Effective touch response time	Less than 80 ms
Water resistance	Watering or spraying water on the panel will not cause malfunction of keys; when flooded or with water accumulation, no abnormal response occurs by touching the panel.
RFI resistance	Effectively suppress RFI (radio frequency interference) caused when GSM cell phone is used to make a call or answer a call next to the panel or a talk proceeds next to the panel over high-power walkie-talkie.
Operating voltage range	3.3V-5.5V
Operating temperature range	–40°C—+85°C
Data transmission interface	IIC and BCD are selectable
Storage temperature range	–50°C—+125C
Chip sealing mode	NSOP16(150MIL)
Typical application	Various home appliances, security equipment, communication equipment, industrial control equipment & instruments, entertainment equipment, medical equipment, sport facilities, toy,etc.

Table of Contents



Table of Contents

- 1. Product Introduction..... 3
 - 1.1 Parameters..... 3
 - 1.2. Typical application..... 3
 - 1.3. Chip Package Type..... 3
 - 1.4. Definitions of WTC7508DSI Pins and pin configuration diagram..... 3
 - WTC7508DSI pin configuration diagram is shown figure 1:..... 3
- 2. The touch-sensitive key..... 4
 - 2.1 WTC7508DSI Technical features of the touch-sensitive key..... 4
 - 2.2. Working circuit diagram of WTC7508DSI..... 5
 - 2.3.The Capacitive Sensor (Key sense element)..... 6
 - 2.3.1 The material, shape and area of the capacitive sensor (key sense element)..... 6
 - 2.3.2. The clearance of adjacent capacitance sensor (key sense element)..... 7
 - 2.3.3 Capacitance sensor (key sense element) to the pin connection of WTC7508DSI..... 7
 - 2.3.4. WTC7508DSI of Vacant Sensor Channel..... 7
 - 2.3.5. The material and thickness of the panel..... 7
 - 2.3.6. The installation of the touch key board..... 8
 - 2.3.7 The setting of the sensitivity and setting capacitance CSEL of the sensitivity..... 8
 - 2.3.8. The software assistant of the touch induction sensitivity..... 8
 - 2.3.9 Matched resistance of the channel..... 9
 - 2.3.10 Exempt from debugging for the volume production..... 9
- 3. BCD code output signal of WTC7508DSI..... 9
 - 3.1 How to choose BCD output of WTC7508DSI..... 9
 - 3.2. Data when BCD code is output..... 9
- 4. IIC interface of WTC7508DSI..... 10
 - 4.1 How to select and use the IIC interface of WTC7508DSI..... 10
 - 4.2 The address setting of IIC interface..... 10
 - 4.3 Introduction of WTC7508DSI IIC interface..... 10
 - 4.4 Read the touch key information..... 10
 - 4.5 Set the induction sensitivity of the touch key..... 12
 - 4.6 Matters needing attention for the sensor sensitivity of the touch key set by the software..... 12
- 5. WTC7508DSI Power Supply..... 13
 - 5.1 DC Voltage Stabilizer for power supply..... 13
 - 5.2. Placement of Voltage regulator circuit..... 14
 - 5.3. Precautions for High Noise Condition..... 14
 - 5.4. Power Filter..... 14
 - 5.5. Use of +5V Power Supply of the Host..... 14
- 6. Package Dimension Drawing of WTC7508DSI..... 15



WTC7508DSI 8-Channel Capacitive-Sensing Touch Button Chip

Specification (V1.1)

1. Product Introduction

WTC7508DSI is a kind of touch-sensitive key chip. The interior of this chip integrates the 8 channel capacitance measurement circuit, the calibration circuit and RISC processor of the independent design, provides the users with 8 man-machine interface scheme of capacitive touch sensitive key. Technical

1.1 Parameters

It meets the industrial application specification, can provide the users with more reliable performance.

Operating voltage: $3.3V < V_{cc} < 5.5V$

Output voltage range: $GND < V_{out} < V_{cc}$

Sensing thickness (insulating medium): 0-20mm

Response time of effective touch: Less than 140ms

Operating temperature: $-40^{\circ}C \text{---} +85^{\circ}C$

Storage temperature: $-50^{\circ}C \text{---} +125^{\circ}C$

1.2. Typical application

It is applicable to various kinds of kitchen equipment, audio and video equipment, air conditioner, sanitary appliance, lamp switch, safety defense, instrument, portable player, electronic toys and learning machine and other products..

1.3. Chip Package Type

WTC7508DSI is packaged with standard NSOP16(150mil).

1.4. Definitions of WTC7508DSI Pins and pin configuration diagram

WTC7508DSI pin configuration diagram is shown figure 1:

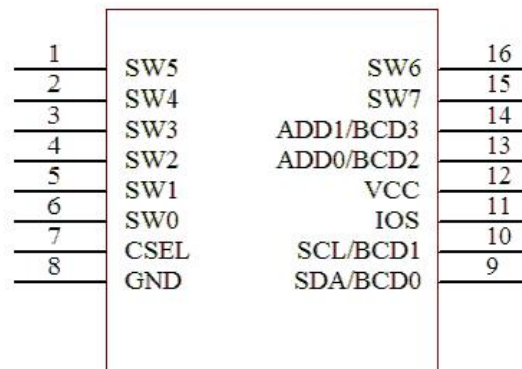

Figure 1: WTC7508DSI pin configuration diagram

The table 1 is the definitions of WTC7508DSI pins

Table 1

Pin No.	Pin Name	Usage	Function Description
1	SW5	I	Capacitive sensor (sense element) interface 5
2	SW4	I	Capacitive sensor (sense element) interface 4
3	SW3	I	Capacitive sensor (sense element) interface 3
4	SW2	I	Capacitive sensor (sense element) interface 2
5	SW1	I	Capacitive sensor (sense element) interface 1
6	SW0	I	Capacitive sensor (sense element) interface 0
7	CSEL	I	Capacitor interface for adjusting the sensitivity
8	GND	I	Power ground
9	SDA/BCD0	I	The data line of the Chip IIC interface. When BCD is output, the data is 1 bit (8421 code)
10	SCL/BCD1	I	The clock input line of the chip IIC interface. When BCD is output, the data is 2 bit (8421 code)
11	IOS	I	The selected foot of output interface. When connecting GND, the IIC bus mode is making the data exchange externally. When connecting VCC, the BCD code (8421) mode to externally output key value when connecting VCC chip.
12	VCC	I	positive power supply output
13	ADD0/BCD2	I	The address set foot of the chip IIC interface. When BCD is output, the data is 3 bit (8421 code).
14	ADD1/BCD3	I	The address set foot of the chip IIC interface. When BCD is output, the data is 4 bit (8421 code).
15	SW7	I	Capacitive sensor (sense element) interface 7
16	SW6	I	Capacitive sensor (sense element) interface 6

2. The touch-sensitive key

2.1 WTC7508DSI Technical features of the touch-sensitive key

Through 8 independent of the capacitance sensor input channel, WTC7508DSI detects capacitance change on the touch-key sense element, and through a series of efficient algorithms, identifies the effective touch of the finger. The user can read the key data through the standard 2 line IIC interface and can also select the simple BCD code interface (through IOS foot section).

The use of special waterproof design: The keyboard not only can splash-proof and splash-proof, but also can be commonly used after completely flooded. It is different from the general induction key panel that when splashing water, flood water, it easily false action, and is lags in response after waterlogging. Or after the finger is pressed, the undesired key value is false action.

Excellent anti-electromagnetic interference: When it is used in the home appliances and general application products. The user can obtain good radio-frequency signal interference ability by using single-sided PCB board, and can easily withstand the interference of most RF interferer sources, including GSM mobile phones.

WTC7508DSI

Unique line length correction function: similar products currently on the market, there is a large difference phenomenon due to the sensitivity of the sensor is different from the length of the wire to the IC pin. Our original wire length self-correction technique can automatically correct this difference. The user does not need the complicated adjustment to obtain the almost universal sensitivity of each key of the entire panel

2.2. Working circuit diagram of WTC7508DSI

The peripheral circuit of WTC7508DSI is very simple, and only needs a few resistors and capacitors that it can work

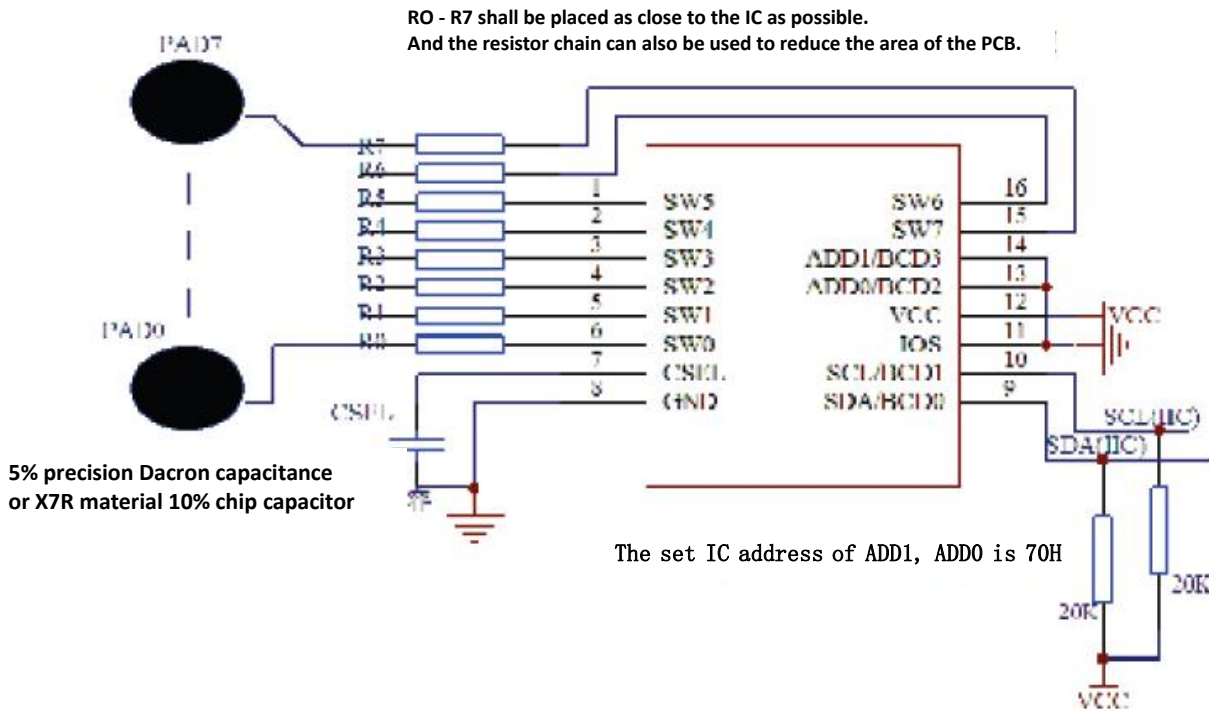

Figure 2: Working circuit diagram of using IIC interface of WTC7508DSI

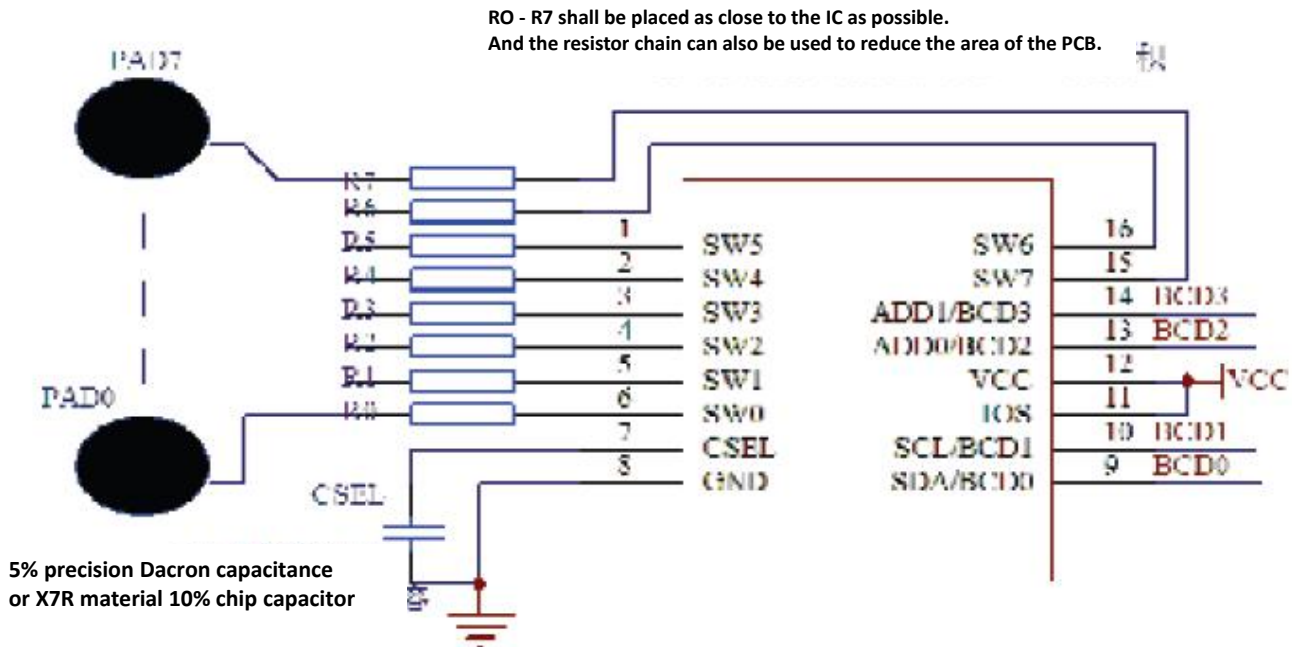

Figure 3: Working circuit diagram of using BCD code (8421) interface of WTC7508DSI

2.3.The Capacitive Sensor (Key sense element)

2.3.1 The material, shape and area of the capacitive sensor (key sense element)

There are certain conductive objects of the plane surface, such as metal foil, sheet metal, conductive ink, metal cotton, conductive rubber and the ITO coating on the conductive glass, etc., which can be used as a key sense element, and the Metal spring (FIG. 3) or the copper foil on PCB (FIG 4) key sense element commonly used in household appliances can be round, oval, polygons, or any geometric figure with certain area. in general situation, the area of each sense element should remain the same as far as possible, to ensure the same sensitivity. Increasing the area of the sense element can increase the capacity of capacitance induction and increase the sensitivity



Figure 4: capacitance sensor made by metal spring (key sense element)

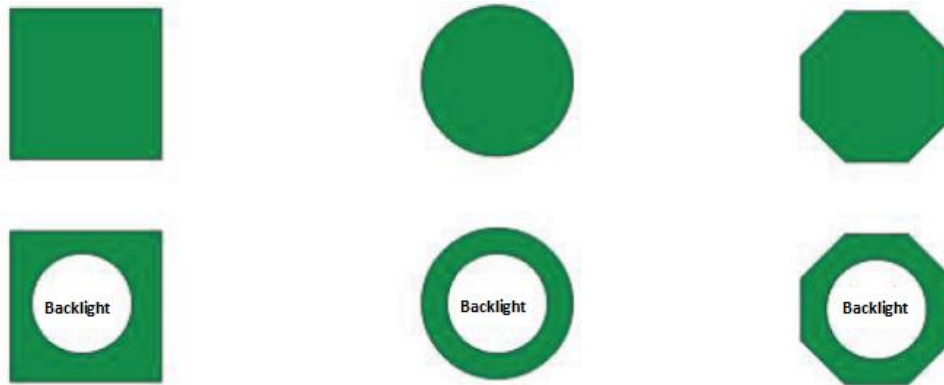

The key sense element can be solid or hollow rectangle, circle or polygon.

Figure 5: PCB Copper Foil Sense Element

2.3.2. The clearance of adjacent capacitance sensor (key sense element)

WTC7508DSI is used for adjacent key suppression function can prevent the wrong action of adjacent keys. The user can use the compact keyboard of smaller spacing (the spacing is not less than 2mm)

2.3.3 Capacitance sensor (key sense element) to the pin connection of WTC7508DSI

The connection between the capacitance sensor and the pins should be short and thin as far as possible (0.~0.3 mm). It is best that WTC7508DSI can be placed on the keypad and that the back and around 0.5 mm of the connection is not placed other circuit, to ensure that the sensor has good sensitivity and to avoid false triggering.

2.3.4. WTC7508DSI of Vacant Sensor Channel

WTC7508DSI requires that at least three touch keys must be used; otherwise the chip will not work properly. When using it in the case of less than 8 keys, SW7 ~ SW0 will have empty and unused sensor input channel. The empty input channel is simply suspend in midair. Do not add any pulling-up or dropping-down resistance and capacitance.

If the user must use three or less sensitive keys, please be sure to contact us for the corresponding technical support.

2.3.5. The material and thickness of the panel



The panel must be made of insulating materials such as glass, plastic, acrylic, etc. The different panel materials with different dielectric constants, in the general situation, for the panel of the same thickness made of different materials, the greater dielectric constant, the higher sensitivity of the touch- induction, and the smaller the dielectric constant, the lower the sensitivity.

The following is the dielectric constant of several common panels, common glass (or toughened glass): 7, acrylic (plexiglass); 3.5. Air: 1. this is why the air gap must be removed when the touch panel is installed. For the same kind of material panel, the thicker the panel is, the lower the sensitivity of the key is. The thinner the panel is, the higher the sensitivity is.

2.3.6. The installation of the touch key board

The gap of the capacitance sensor (key sense element) and the back of panel, must be eliminated with strong joint clearance, if the junction of the back of panel and key has concave and convex, the insulation colloidal fillings, such as insulating silicone can be used for it to fill and level up the contact surface, to ensure that the junction surface between the panel and key sense element is no air gap between.

2.3.7 The setting of the sensitivity and setting capacitance CSEL of the sensitivity

After the touch induction key plate is designed well, and the material and thickness of the panel is selected, and the installation way is determined, one adjusting one capacitance Csel value, it can change all channel sensitivity to adapt the different thickness of the panel, to reach the optimum touch-sensitive effect. Through choosing appropriate Csel capacitance values, it can make the WTC7508DSI to adapt to the different thickness of 0 to 20mm insulation panels. The larger the separation medium is, the larger the Csel capacity is. It is generally recommended to choose the appropriate capacitance between 0.0022 UF and 0.022 UF from large to small

CSEL is the benchmark of sensitivity. The material and precision of CSEL are very important for the working stability. Please always remember to use the capacitance of poor stability and excessive temperature

The CSEL of WTC7508DSI requires the use of the accuracy of 5% or above of the precision of the polyester capacitance, NPO material or 10% and above precision X7R material

Increasing the area of the sense element can improve the penetrating power of capacitance induction and improve the sensitivity

2.3.8. The software assistant of the touch induction sensitivity

When it is applied to the situation which has the strict requirements for the sensitivity, if the most satisfactory CSEL cannot be founded to implement the required sensitivity, after fixing the CSEL value, the software can be used through serial interface to make the auxiliary adjustment to the sensitivity of touch key, to achieve the best touch-sensitive sensitivity. For the method of using software to assist in adjusting the sensitivity of touch keys, please read the relevant content of chapter 4.

The assistant software of touch key induction sensitivity has 32 sensitivity series. The corresponding series data is 0 ~31, which is written by the master control grounding serial interface and the sensitivity series buffer



of WTC7508DSI. The higher the series is, the higher the sensitivity of the touch key is. However, the high-determined series data will be invalid if it exceeds 31. The previous sensitivity parameter will still be used.

After WTC7508DSI is electrified for the first time, the interior of the sensitivity level will automatically set to 29. In the most situations, the user does not have to use the software sensitivity to make the assisted adjustment, and only needs to adjust the size of the CSEL that can get satisfactory sensitivity.

2.3.9 Matched resistance of the channel

1K resistance concatenated by each capacitance sensor channel can make WTC7508DSI work in the best of the most stable state of capacitance measurement. When it is the PCB layout, the CSEL must make CSEL and the matching resistor close to the IC as close as possible. Generally it does not need to adjust the matching resistance value. In some special cases, it can adjust the matched resistance value on one measurement channel, to change the channel touch-sensitive sensitivity, to increase matching resistance, and can reduce the sensitivity, to reduce the matching resistance, may be increased sensitivity. Special attention: through adjusting the capacitance of CSEL, the optimum sensitivity of touch sensitivity can be obtained. Therefore, it is not necessary to adjust the sensitivity by changing the matching resistance value

2.3.10 Exempt from debugging for the volume production

The system is not calibrated after the value of sensitivity capacitance Csel is determined in the research and development and experimental phase. The system can automatically control the interference caused by electrostatic discharge, electromagnetic interference, temperature change, moisture and pollutants on the surface, provides the good accuracy and operational consistency in various environments. Products can be transported in long distances and can be used in a variety of environments. The unique compensation algorithm and high-strength anti-jamming design can guarantee that the product will not be misused in the long term. The production is exempt from debugging, with extremely high production efficiency.

3. BCD code output signal of WTC7508DSI

3.1 How to choose BCD output of WTC7508DSI

When IOS foot of WTC7508DSI is connected to VCC, the BCD code output is used for the key value of WTC7508DSI

3.2. Data when BCD code is output

When there is no finger touch the sense element chip, the data output by BCD3~BCD0 pin is 0(8421 code). When the effective touch on sense element occurred is detected, in 150ms, through BCD3~BCD0 pin, WTC7508DSI outputs the BCD code of the corresponding plate channel, so that to deal with MUC when finger is left the sense element, the BCD3~BCD0 pin recovers to be 0

The following figure is a sequence diagram of BCD data output

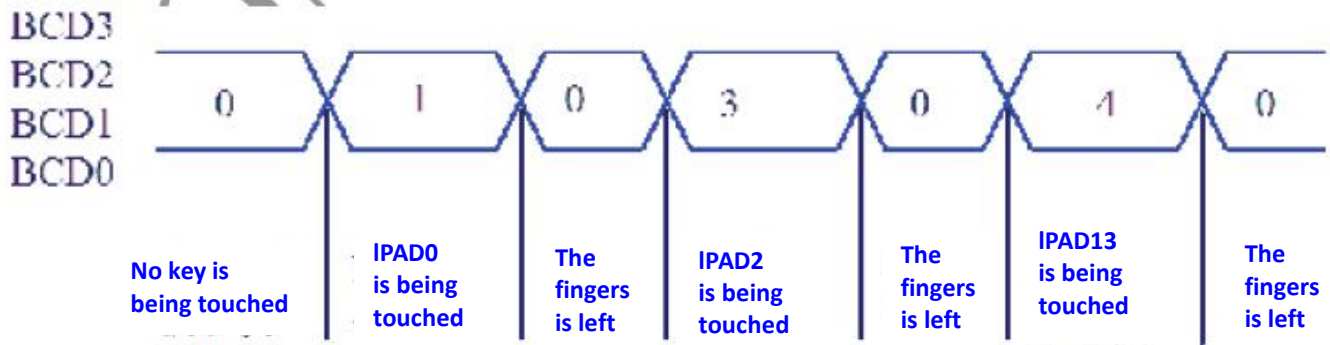

Figure 6: Sequence diagram of BCD data output

4. IIC interface of WTC7508DSI

4.1 How to select and use the IIC interface of WTC7508DSI

When the I0S foot of WTC7508DSI is connected to GND, the master control MCU can operate the WTC7508DSI through the SCL and SDA pin of WTC7508DSI by using the standard IIC protocol.

4.2 The address setting of IIC interface

WTC7508DSI can set the slave address of the chip through the connected relation of the 13th and 14th feet foot with VCC and GND. The corresponding relationship is shown in the table below.

Connected relation	PIN13-GND PIN14-GND	PIN13-VCC PIN14-GND	PIN13-GND PIN14-VCC	PIN13-VCC PIN14-VCC
IIC address	70H (16 hexadecimal)	74H(16 hexadecimal)	78H (16 hexadecimal)	7CH (16 hexadecimal)

When using IIC interface, the 13th and 14th feet cannot be suspended in midair, please be sure to connect with VCC and GND

4.3 Introduction of WTC7508DSI IIC interface

The interior of WTC7508DSI integrates a standard IIC slave interface. The maximum speed can reach 400 KHz.

4.4 Read the touch key information

1:Generate the "start" signal of the IIC bus

When SCL is the high level, the "start" signal of IIC can be generated by setting the SDA as the low level from the high level.

It's important to note that only generating the IIC "start" signal and the "end" signal, it can change the SDA electrical level when SDA is the high level, the rest of the time only when SCL is the low level, the degree of the SDA electrical level can be operated.

2: It generates 7 address bits and a read-write select bit.

It also determines whether a valid address request is received from the slave by judging whether the signal responded from the slave is normal.

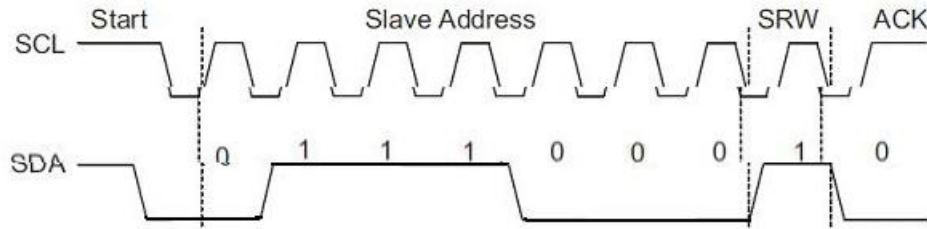

Figure 7: When reading the data, the sequence diagram of IIC "start" signal and the slave address are generated

3: Read the key information of the 1byte

The data format of key information is

Data bit	Bit7	Bit6	Bit5	Bit4	Bit3	Bit2	Bit1	Bit0
Meaning	SW7	SW6	SW5	SW4	SW3	SW2	SW1	SW0

On SW7~SW0, the no induced touch data bit is "0", and the induced touch data bit is "1"

4: After reading the key information of the key information, the host does not generate a response bit to notify the touch the touch chip that it no longer continues to transmit the subsequent information

5: The "end" signal that produces the IIC bus releases the IIC bus.

When SCL is high level, the SDNA is set to be the high level from low level, that the "end" signal of IIC can be generated.

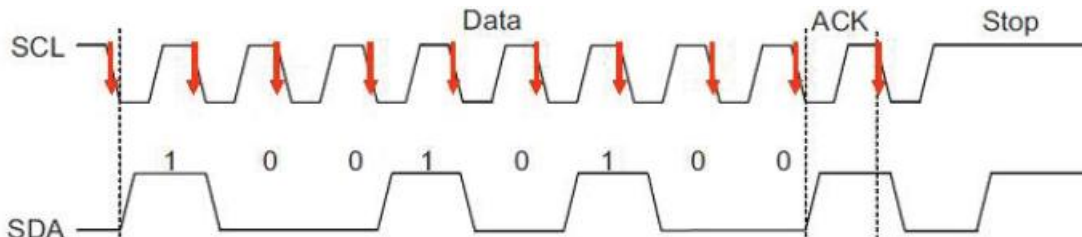

Figure 9: The sequence diagram second key information data and generated "end" when reading the data

4.5 Set the induction sensitivity of the touch key

1: Generate the "start" signal of the IIC bus

2: Generate 7 address bit and a read-write select bit. And through judging if the response signal of the slave is normal, it determines whether the slave has received the valid address request

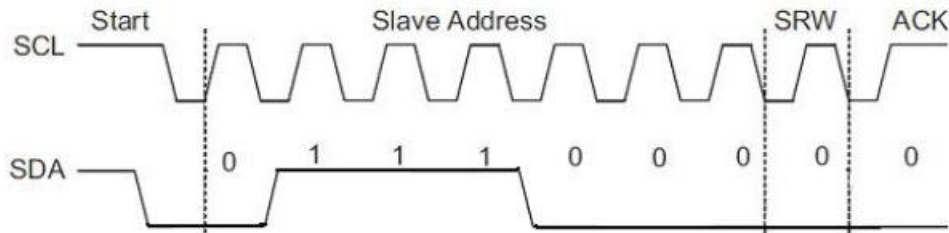

Figure 10: When the sensitivity data is written, it generates the IIC "start" signal and the sequence diagram of the slave address

3: Write 1byte sensitivity to the touch chip to adjust the data. Data is sent in sequence from high to low.

4: The "end" signal of generating IIC bus releases the IIC bus.

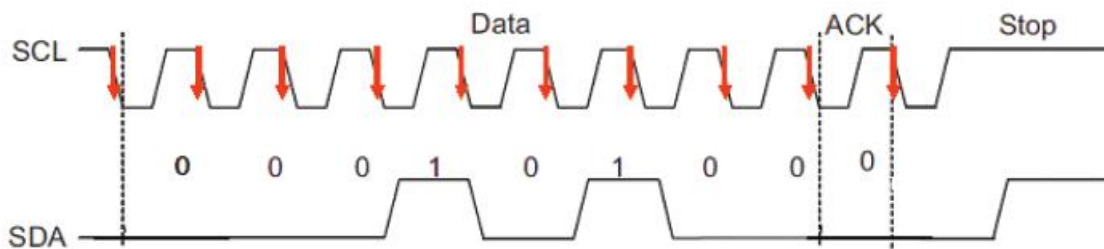

Figure 11: when writing sensitivity data, it generated "end" signal and the sequence diagram of the slave address

5: The touch chip resets the bit and resets the internal relevant parameters by using the sensitivity number of this setting.

4.6 Matters needing attention for the sensor sensitivity of the touch key set by the software

The master control MCU will be reset every time after the sensitivity is set and the reset needs 50ms.

In the 50ms time of the touch chip is reset, regardless of whether it is reading or writing, it will get the correct result. Therefore, the master control MCU must wait for more than 50ms then it can read and write to the serial interface of WTC7508DSI after the completion of setting sensitivity.

It is recommended that MCU should not frequently set the sensitivity of touch chip in the program. Just it is set once when the program is initialized.

The sensitivity of touch key is divided into 32 series, corresponding series data is 0 ~ 31.

The higher the series is, the higher the sensitivity of the touch key is.

But if the set series is more than 31, this set will be invalid. After the invalid set is transmitted to the end bit, the touch chip will not be reset, also won't to adjust internal parameters, and the previous sensitivity parameters can be used.

After the touch chip is electrified for the first time, the interior of the sensitivity is automatically set to 29 series, and the user does not need to use the software to adjust the sensitivity and can use the default parameters of chip directly.

For the details of the DEMO program, Please refer to the C language source code DEMO_IIC_7508.C provided by us as (the operation sequence of 8051 IIC bus generated by IO port simulation of the host)

Please view the DEMO_IIC_75 file by using a non-text editor such as UltraEdit. This sample program is written to be fully compliant with the standard IIC specification and can be modified slightly to operate other IIC devices.

5. WTC7508DSI Power Supply

5.1 DC Voltage Stabilizer for power supply

WTC7508DSI measures small change in capacitance, so it is required that the power ripple and noise should be small and the external strong interference involved from power supply shall be avoided. Particularly when it is applied to induction cooker and microwave oven, the external interference and voltage leap must be effectively isolated, and the power supply must have high stability. It is suggested that the voltage stabilizing circuit constituted by 78L05 as shown in the figure 9 should be adopted. The C2 capacity affects the discharge time after power failure. Too large capacity requires a longer reset time. In the figure, it is the recommended value, and the different applications can be flexibly adjusted. The figure 9 is DC Voltage regulator circuit.

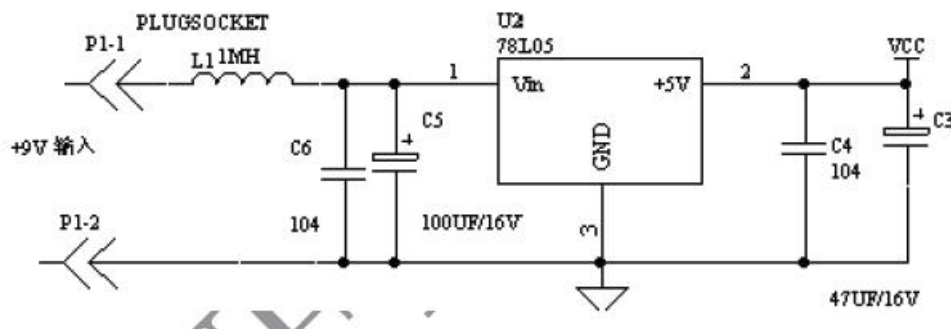

Figure 9: DC Voltage regulator circuit

5.2. Placement of Voltage regulator circuit

At PCB LAYOUT, such 78L05 power component must be close to WTC7508DSI Vcc pin.

78L05, peripheral components and WTC7508DSI must be placed on the same circuit board centrally, to put an end to the noises caused by overlong power connection line.

Grounding The common ground of the components as shown in the figure shall be separately connected into an independent group and then it shall be connected to the common ground of the whole machine from one point of it. (Use one point of star shape to connect the ground)

5.3. Precautions for High Noise Condition

In case of application in a high-noise environment, up and down overlapped placement shall be avoided between high-voltage (220V), high-current, and high-frequency-operation main board and the touch circuit board. If such overlapped placement is unavoidable, try to keep far a channel from high-voltage, high-current components area or add shield on the main board.

5.4. Power Filter

When typesetting in PCB, it is recommended to reserve the inductor L1 (1MH) welding disc, but the general and the non-special applications do not need this inductance. The users can also cancel it.

When inputting 78L05 power supply, it needs to pay attention to ripple size. Please don't make the trough of ripple wave lower than DC 9V.

5.5. Use of +5V Power Supply of the Host

If the user directly uses 5V power supply of the main engine, it needs adding the power supply filter circuit in the front of the power supply of the modules or sensing power chips as shown in the figure. The requirement for PCB layout is the same as the above circuit

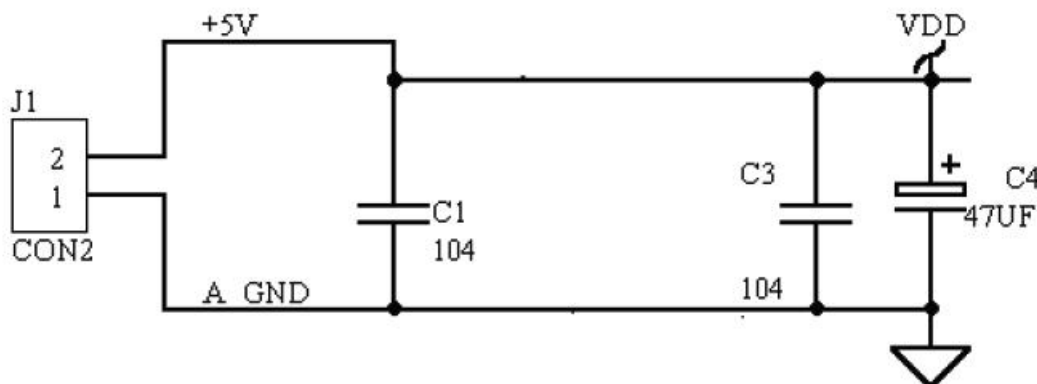

The analog and digital powers of circuit shall be connected separately to the ground in Y-connection method.



The capacitors shall be arranged in the sequence indicated in the schematic diagram and shall not be arranged arbitrarily.

Figure 7: Power Filter Circuit

Precautions:

The above circuit should connect the 104 capacitors and electrolytic capacitors of the filter circuit according to the order in the chart, and 104 capacitors should be in front of the electrolytic capacitance that can better suppresses the high frequency noise.

6. Package Dimension Drawing of WTC7508DSI

Symbol	Dimensions in mm		
	Min.	Nom.	Max.
A	1.35	1.60	1.75
A1	0.10	—	0.25
A2	—	1.45	—
B	0.33	—	0.51
C	0.19	—	0.25
D	9.80	—	10.00
E	3.80	—	4.00
c	—	1.27	—
H	5.80	—	6.20
L	0.40	—	1.27
θ	0.00	—	8.00

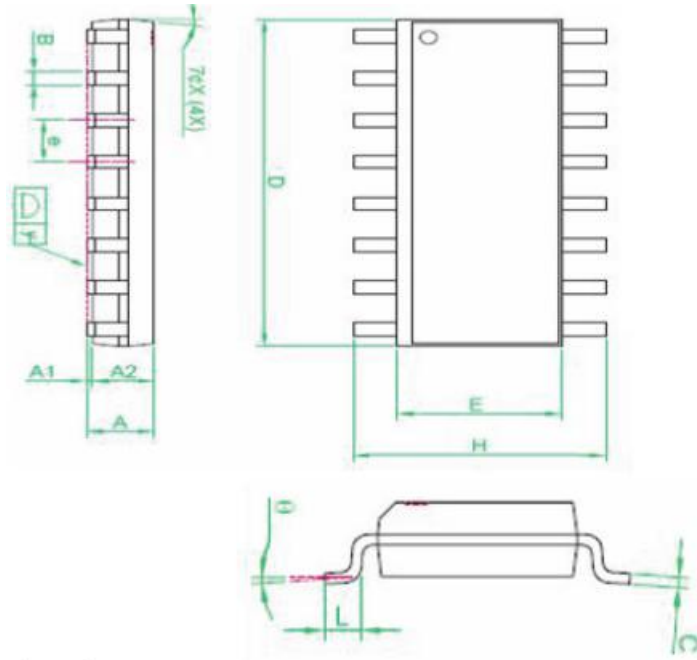

Figure 11: Package Dimension Drawing of WTC7508DSI