

## New Features

- Monitor Voltages: 5V to 1.6V
- Memory Security
- Battery Switch Backup
- $V_{OUT}$  5mA to 50mA

## Preliminary Datasheet



## 4kbit EEPROM

## X40420/X40421

### Dual Voltage Monitor with Integrated CPU Supervisor and System Battery Switch

#### FEATURES

- Dual voltage detection and reset assertion
  - Three standard reset threshold settings (4.6V/2.9V, 4.6V/2.6V, 2.9V/1.6V)
  - $V_{TRIP2}$  Programmable down to 0.9V
  - Adjust low voltage reset threshold voltages using special programming sequence
  - Reset signal valid to  $V_{CC} = 1V$
  - Monitor two voltages or detect power fail
- Battery Switch Backup
- $V_{OUT}$ : 5mA to 50mA from  $V_{CC}$ ; or 250 $\mu$ A from  $V_{BATT}$
- Fault detection register
- Selectable power on reset timeout (0.05s, 0.2s, 0.4s, 0.8s)
- Selectable watchdog timer interval (25ms, 200ms, 1.4s, off)
- Debounced manual reset input
- Low power CMOS
  - 25 $\mu$ A typical standby current, watchdog on
  - 6 $\mu$ A typical standby current, watchdog off
  - 1 $\mu$ A typical battery current in backup mode
- 4Kbits of EEPROM
  - 16 byte page write mode
  - Self-timed write cycle
  - 5ms write cycle time (typical)
- Built-in inadvertent write protection
  - Power-up/power-down protection circuitry
  - Block lock protect 0 or 1/2, of EEPROM
- 400kHz 2-wire interface
- 2.7V to 5.5V power supply operation
- Available packages
  - 14-lead SOIC, TSSOP

#### APPLICATIONS

- Communications Equipment
  - Routers, Hubs, Switches
  - Disk arrays
- Industrial Systems
  - Process Control
  - Intelligent Instrumentation
- Computer Systems
  - Desktop Computers
  - Network Servers

#### X40420/21

Standard $V_{TRIP1}$ Level	Standard $V_{TRIP2}$ Level	Suffix
4.6V (+/-1%)	2.9V (+/-1.7%)	-A
4.6V (+/-1%)	2.6V (+/-2%)	-B
2.9V (+/-1.7%)	1.6V (+/-3%)	-C

See "Ordering Information" for more details  
For Custom Settings, call Xicor.

#### DESCRIPTION

The X40420/21 combines power-on reset control, watchdog timer, supply voltage supervision, and secondary supervision, manual reset, and Block Lock™ protect serial EEPROM in one package. This combination lowers system cost, reduces board space requirements, and increases reliability.

Applying voltage to  $V_{CC}$  activates the power on reset circuit which holds RESET/RESET active for a period of time. This allows the power supply and system oscillator to stabilize before the processor can execute code.

#### BLOCK DIAGRAM

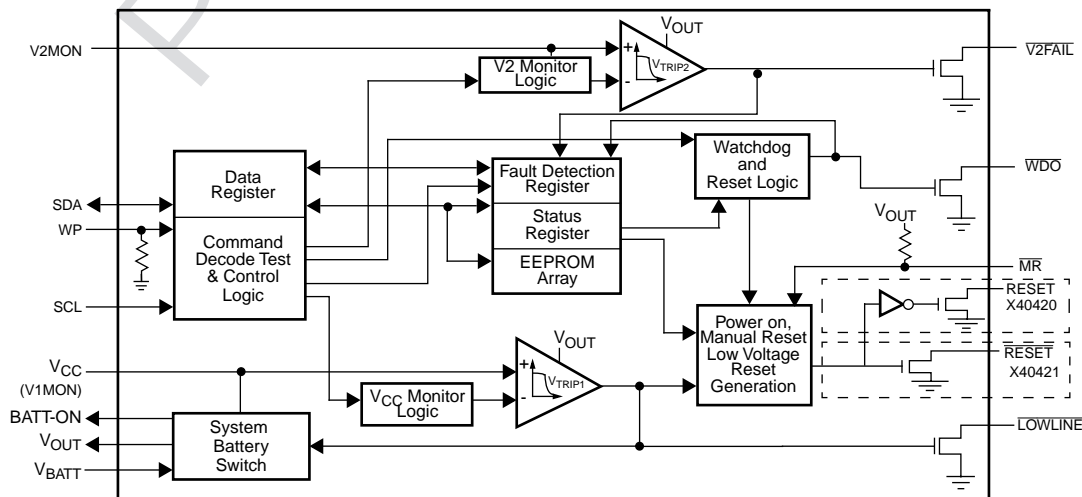

# X40420/X40421 – Preliminary

Low  $V_{CC}$  detection circuitry protects the user's system from low voltage conditions, resetting the system when  $V_{CC}$  falls below the minimum  $V_{TRIP1}$  point. RESET/RESET is active until  $V_{CC}$  returns to proper operating level and stabilizes. A second voltage monitor circuit tracks the unregulated supply to provide a power fail warning or monitors different power supply voltage. Three common low voltage combinations are available, however, Xicor's unique circuits allows the threshold for either voltage monitor to be reprogrammed to meet special needs or to fine-tune the threshold for applications requiring higher precision.

A manual reset input provides debounce circuitry for minimum reset component count.

A battery switch circuit compares  $V_{CC}$  with  $V_{BATT}$  input and connects  $V_{OUT}$  to whichever is higher. This provides voltage to external SRAM or other circuits in the event of main power failure. The X40420/21 can drive 50mA from  $V_{CC}$  to 250 $\mu$ A from  $V_{BATT}$ . The device only switches to  $V_{BATT}$  when  $V_{CC}$  drops below the low  $V_{CC}$  voltage threshold and  $V_{BATT}$ .

The Watchdog Timer provides an independent protection mechanism for microcontrollers. When the microcontroller fails to restart a timer within a selectable time out interval, the device activates the WDO signal. The user selects the interval from three preset values. Once

selected, the interval does not change, even after cycling the power.

The memory portion of the device is a CMOS Serial EEPROM array with Xicor's Block Lock protection. The array is internally organized as x 8. The device features an 2-wire interface and software protocol allowing operation on a two-wire bus.

The device utilizes Xicor's proprietary Direct Write™ cell, providing a minimum endurance of 100,000 cycles and a minimum data retention of 100 years.

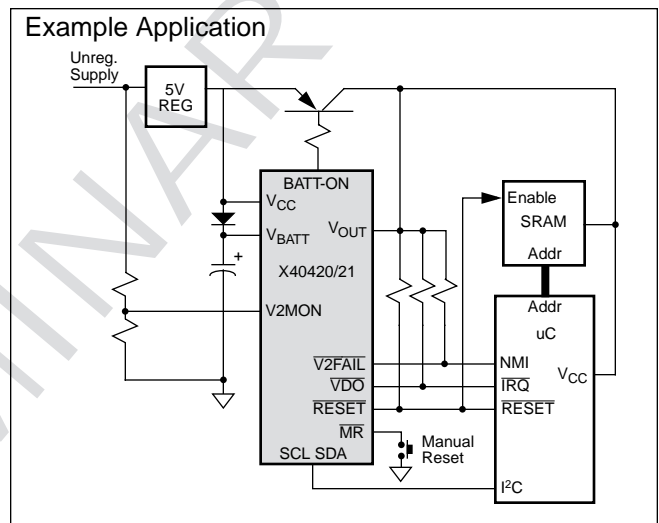

## PIN CONFIGURATION

X40420				X40421			
14-Pin SOIC, TSSOP				14-Pin SOIC, TSSOP			
V <sub>2FAIL</sub>	1	14	V <sub>CC</sub>	V <sub>2FAIL</sub>	1	14	V <sub>CC</sub>
V <sub>2MON</sub>	2	13	BATT-ON	V <sub>2MON</sub>	2	13	BATT-ON
LOWLINE	3	12	V <sub>OUT</sub>	LOWLINE	3	12	V <sub>OUT</sub>
WDO	4	11	V <sub>BATT</sub>	WDO	4	11	V <sub>BATT</sub>
MR	5	10	WP	MR	5	10	WP
RESET	6	9	SCL	RESET	6	9	SCL
V <sub>SS</sub>	7	8	SDA	V <sub>SS</sub>	7	8	SDA

## PIN DESCRIPTION

Pin	Name	Function
1	V <sub>2FAIL</sub>	<b>V2 Voltage Fail Output.</b> This open drain output goes LOW when V <sub>2MON</sub> is less than $V_{TRIP2}$ and goes HIGH when V <sub>2MON</sub> exceeds $V_{TRIP2}$ . There is no power up reset delay circuitry on this pin.
2	V <sub>2MON</sub>	<b>V2 Voltage Monitor Input.</b> When the V <sub>2MON</sub> input is less than the $V_{TRIP2}$ voltage, V <sub>2FAIL</sub> goes LOW. This input can monitor an unregulated power supply with an external resistor divider or can monitor a second power supply with no external components. Connect V <sub>2MON</sub> to V <sub>SS</sub> or V <sub>CC</sub> when not used.
3	LOWLINE	<b>Early Low V<sub>CC</sub> Detect.</b> This open drain output signal goes LOW when $V_{CC} < V_{TRIP1}$ . When $V_{CC} > V_{TRIP1}$ , this pin is pulled high with the use of an external pull up resistor.

## X40420/X40421 – Preliminary

### PIN DESCRIPTION (Continued)

Pin	Name	Function
4	$\overline{WDO}$	<b>WDO Output.</b> $\overline{WDO}$ is an active LOW, open drain output which goes active whenever the watchdog timer goes active.
5	$\overline{MR}$	<b>Manual Reset Input.</b> Pulling the $\overline{MR}$ pin LOW initiates a system reset. The RESET/ $\overline{RESET}$ pin will remain HIGH/LOW until the pin is released and for the $t_{PURST}$ thereafter. It has an internal pull up resistor.
6	RESET/ RESET	<b>RESET Output.</b> (X40421) This open drain pin is an active LOW output which goes LOW whenever $V_{CC}$ falls below $V_{TRIP1}$ voltage or if manual reset is asserted. This output stays active for the programmed time period ( $t_{PURST}$ ) on power up. It will also stay active until manual reset is released and for $t_{PURST}$ thereafter. <b>RESET Output.</b> (X40420) This pin is an active HIGH open drain output which goes HIGH whenever $V_{CC}$ falls below $V_{TRIP1}$ voltage or if manual reset is asserted. This output stays active for the programmed time period ( $t_{PURST}$ ) on power up. It will also stay active until manual reset is released and for $t_{PURST}$ thereafter.
7	$V_{SS}$	Ground
8	SDA	<b>Serial Data.</b> SDA is a bidirectional pin used to transfer data into and out of the device. It has an open drain output and may be wire ORed with other open drain or open collector outputs. This pin requires a pull up resistor and the input buffer is always active (not gated). <b>Watchdog Input.</b> A HIGH to LOW transition on the SDA (while SCL is toggled from HIGH to LOW and followed by a stop condition) restarts the Watchdog timer. The absence of this transition within the watchdog time out period results in $\overline{WDO}$ going active.
9	SCL	<b>Serial Clock.</b> The Serial Clock controls the serial bus timing for data input and output.
10	WP	<b>Write Protect.</b> WP HIGH prevents writes to any location in the device (including all the registers). It has an internal pull down resistor. (>10M $\Omega$ typical)
11	$V_{BATT}$	<b>Battery Supply Voltage.</b> This input provides a backup supply in the event of a failure of the primary $V_{CC}$ voltage. The $V_{BATT}$ voltage typically provides the supply voltage necessary to maintain the contents of SRAM and also powers the internal logic to “stay awake.” If the battery is not used, connect $V_{BATT}$ to ground.
12	$V_{OUT}$	<b>Output Voltage. (V)</b> $V_{OUT} = V_{CC}$ if $V_{CC} > V_{TRIP1}$ . IF $V_{CC} < V_{TRIP1}$ then $V_{OUT} = V_{CC}$ if $V_{CC} > V_{BATT} + 0.03V$ else $V_{OUT} = V_{BATT}$ (ie if $V_{CC} < V_{BATT} - 0.03V$ ) <b>Note:</b> There is hysteresis around $V_{BATT} \pm 0.03V$ point to avoid oscillation at or near the switchover voltage. A capacitance of 0.1 $\mu F$ must be connected to $V_{OUT}$ to ensure stability.
13	BATT-ON	<b>Battery On.</b> This CMOS output goes HIGH when the $V_{OUT}$ switches to $V_{BATT}$ and goes LOW when $V_{OUT}$ switches to $V_{CC}$ . It is used to drive an external PNP pass transistor when $V_{CC} = V_{OUT}$ and current requirements are greater than 50mA.  The purpose of this output is to drive an external transistor to get higher operating currents when the $V_{CC}$ supply is fully functional. In the event of a $V_{CC}$ failure, the battery voltage is applied to the $V_{OUT}$ pin and the external transistor is turned off. In this “backup condition,” the battery only needs to supply enough voltage and current to keep SRAM devices from losing their data—there is no communication at this time.
14	$V_{CC}$	Supply Voltage

# X40420/X40421 – Preliminary

## PRINCIPLES OF OPERATION

### Power On Reset

Applying power to the X40420/21 activates a Power On Reset Circuit that pulls the RESET/RESE $\bar{T}$  pins active. This signal provides several benefits.

- It prevents the system microprocessor from starting to operate with insufficient voltage.
- It prevents the processor from operating prior to stabilization of the oscillator.
- It allows time for an FPGA to download its configuration prior to initialization of the circuit.
- It prevents communication to the EEPROM, greatly reducing the likelihood of data corruption on power up.

When  $V_{CC}$  exceeds the device  $V_{TRIP1}$  threshold value for  $t_{PURST}$  (selectable) the circuit releases the RESE $\bar{T}$  (X40421) and RESET (X40420) pin allowing the system to begin operation.

**Figure 1. Connecting a Manual Reset Push-Button**

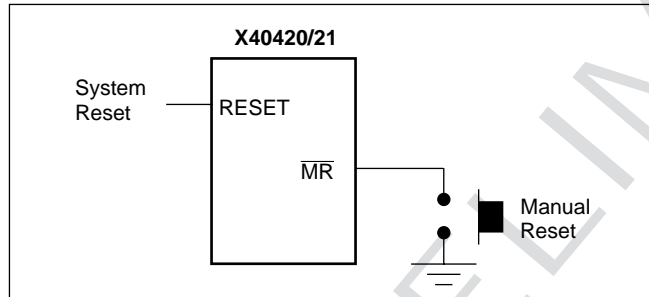

### Manual Reset

By connecting a push-button directly from  $\overline{MR}$  to ground, the designer adds manual system reset capability. The  $\overline{MR}$  pin is LOW while the push-button is closed and RESET/RESE $\bar{T}$  pin remains LOW for  $t_{PURST}$  or till the push-button is released and for  $t_{PURST}$  thereafter. A weak pull up resistor is connected to the  $\overline{MR}$  pin.

### Low Voltage V1 Monitoring

During operation, the X40420/21 monitors the  $V_{CC}$  level and asserts RESE $\bar{T}$  if supply voltage falls below a preset minimum  $V_{TRIP1}$ . The RESE $\bar{T}$  signal prevents the microprocessor from operating in a power fail or brownout condition. The  $\overline{V1FAIL}$  signal remains active until the voltage drops below 1V. It also remains active until  $V_{CC}$  returns and exceeds  $V_{TRIP1}$  for  $t_{PURST}$ .

### Low Voltage V2 Monitoring

The X40420/21 also monitors a second voltage level and asserts  $\overline{V2FAIL}$  if the voltage falls below a preset minimum  $V_{TRIP2}$ . The  $\overline{V2FAIL}$  signal is either ORed with RESE $\bar{T}$  to prevent the microprocessor from operating in a power fail or brownout condition or used to interrupt the microprocessor with notification of an impending power failure. The  $\overline{V2FAIL}$  signal remains active until the  $V_{CC}$  drops below 1V ( $V_{CC}$  falling). It also remains active until  $V2MON$  returns and exceeds  $V_{TRIP2}$ .

$V2MON$  voltage monitor is powered by  $V_{OUT}$ . If  $V_{CC}$  and  $V_{BATT}$  go away,  $V2MON$  cannot be monitored.

**Figure 2. Two Uses of Multiple Voltage Monitoring**

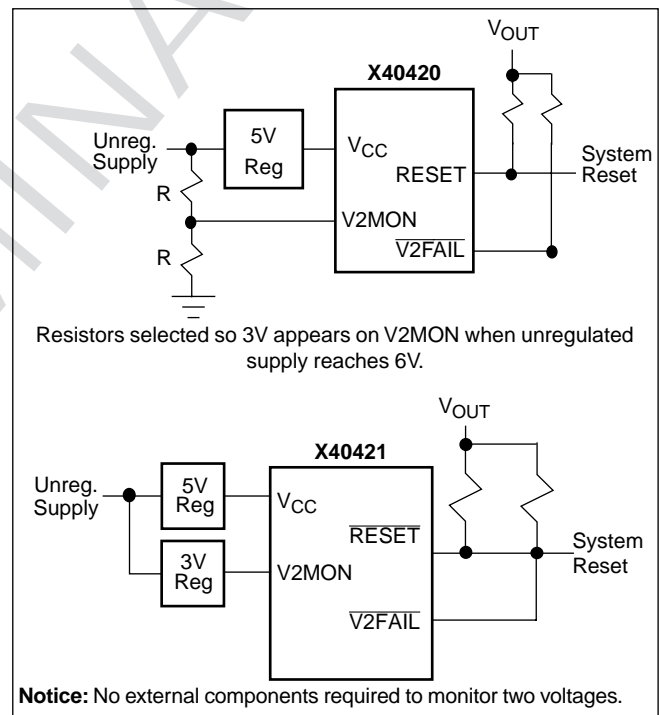

### WATCHDOG TIMER

The Watchdog Timer circuit monitors the microprocessor activity by monitoring the SDA and SCL pins. A standard read or write sequence to any slave address byte restarts the watchdog timer and prevents the  $\overline{WDO}$  signal to go active. A minimum sequence to reset the watchdog timer requires four microprocessor instructions namely, a Start, Clock Low, Clock High and Stop. The state of two nonvolatile control bits in the Status Register determine the watchdog timer period. The microprocessor can change these watchdog bits by writing to the X40420/21 control register.

# X40420/X40421 – Preliminary

**Figure 3.  $V_{TRIPX}$  Set/Reset Conditions**

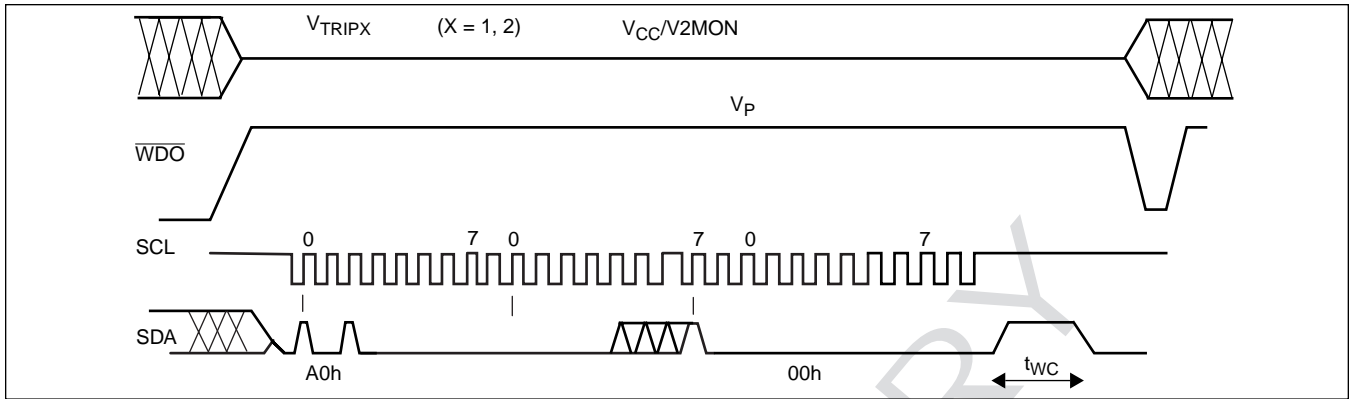

**Figure 4. Watchdog Restart**

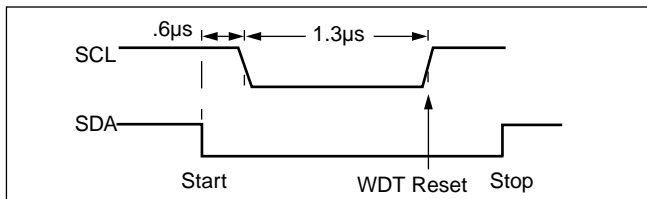

## V1 AND V2 THRESHOLD PROGRAM PROCEDURE (OPTIONAL)

The X40420/21 is shipped with standard V1 and V2 threshold ( $V_{TRIP1}$ ,  $V_{TRIP2}$ ) voltages. These values will not change over normal operating and storage conditions. However, in applications where the standard thresholds are not exactly right, or if higher precision is needed in the threshold value, the X40420 trip points may be adjusted. The procedure is described below, and uses the application of a high voltage control signal.

### Setting a $V_{TRIPx}$ Voltage ( $x=1, 2$ )

There are two procedures used to set the threshold voltages ( $V_{TRIPx}$ ), depending if the threshold voltage to be stored is higher or lower than the present value. For example, if the present  $V_{TRIPx}$  is 2.9 V and the new  $V_{TRIPx}$  is 3.2 V, the new voltage can be stored directly into the  $V_{TRIPx}$  cell. If however, the new setting is to be lower than the present setting, then it is necessary to “reset” the  $V_{TRIPx}$  voltage before setting the new value.

### Setting a Higher $V_{TRIPx}$ Voltage ( $x=1, 2$ )

To set a  $V_{TRIPx}$  threshold to a new voltage which is higher than the present threshold, the user must apply the desired  $V_{TRIPx}$  threshold voltage to the corresponding input pin ( $V_{CC}(V1MON)$  or  $V2MON$ ). Then, a programming voltage ( $V_P$ ) must be applied to the  $\overline{WDO}$  pin before a START condition is set up on SDA. Next, issue on the SDA pin the Slave Address A0h, followed by the Byte Address 01h for  $V_{TRIP1}$ , and 09h for  $V_{TRIP2}$ , and a 00h

Data Byte in order to program  $V_{TRIPx}$ . The STOP bit following a valid write operation initiates the programming sequence. Pin  $\overline{WDO}$  must then be brought LOW to complete the operation.

To check if the  $V_{TRIPx}$  has been set, set  $VXMON$  to a value slightly greater than  $V_{TRIPx}$  (that was previously set). Slowly ramp down  $VXMON$  and observe when the corresponding outputs ( $\overline{LOWLINE}$  and  $\overline{V2FAIL}$ ) switch. The voltage at which this occurs is the  $V_{TRIPx}$  (actual).

### CASE A

Now if the desired  $V_{TRIPx}$  is greater than the  $V_{TRIPx}$  (actual), then add the difference between  $V_{TRIPx}$  (desired) –  $V_{TRIPx}$  (actual) to the original  $V_{TRIPx}$  desired. This is your new  $V_{TRIPx}$  that should be applied to  $VXMON$  and the whole sequence should be repeated again (see Figure 5).

### CASE B

Now if the  $V_{TRIPx}$  (actual), is higher than the  $V_{TRIPx}$  (desired), perform the reset sequence as described in the next section. The new  $V_{TRIPx}$  voltage to be applied to  $VXMON$  will now be:  $V_{TRIPx}$  (desired) – ( $V_{TRIPx}$  (actual) –  $V_{TRIPx}$  (desired)).

**Note:** 1. This operation does not corrupt the memory array.

2. Set  $V_{CC} = 5V$ , when  $V_{TRIP2}$  is being programmed

### Setting a Lower $V_{TRIPx}$ Voltage ( $x=1, 2$ )

In order to set  $V_{TRIPx}$  to a lower voltage than the present value, then  $V_{TRIPx}$  must first be “reset” according to the procedure described below. Once  $V_{TRIPx}$  has been “reset”, then  $V_{TRIPx}$  can be set to the desired voltage using the procedure described in “Setting a Higher  $V_{TRIPx}$  Voltage”.

# X40420/X40421 – Preliminary

## Resetting the $V_{TRIPx}$ Voltage

To reset a  $V_{TRIPx}$  voltage, apply the programming voltage ( $V_p$ ) to the  $\overline{WDO}$  pin before a START condition is set up on SDA. Next, issue on the SDA pin the Slave Address A0h followed by the Byte Address 03h for  $V_{TRIP1}$  and 0Bh for  $V_{TRIP2}$ , followed by 00h for the Data Byte in order to reset  $V_{TRIPx}$ . The STOP bit following a valid write operation initiates the programming sequence. Pin  $\overline{WDO}$  must then be brought LOW to complete the operation.

After being reset, the value of  $V_{TRIPx}$  becomes a nominal value of 1.7V or lesser.

**Note:** This operation does not corrupt the memory array.

## System Battery Switch

As long as  $V_{CC}$  exceeds the low voltage detect threshold  $V_{TRIP}$ ,  $V_{OUT}$  is connected to  $V_{CC}$  through a 5 Ohm (typical) switch. When the  $V_{CC}$  has fallen below  $V_{1TRIP}$ , then  $V_{CC}$  is applied to  $V_{OUT}$  if  $V_{CC}$  is or equal to or greater than  $V_{BATT} - 0.03V$ . When  $V_{CC}$  drops to less than  $V_{BATT} - 0.03V$ , then  $V_{OUT}$  is connected to  $V_{BATT}$  through an 80 Ohm (typical) switch.  $V_{OUT}$  typically supplies the system static RAM voltage, so the switchover circuit operates to protect the contents of the static RAM during a power failure. Typically, when  $V_{CC}$  has failed, the SRAMs go into a lower power state and draw much less current than in their active mode. When  $V_{CC}$  returns,  $V_{OUT}$  switches back to  $V_{CC}$  when  $V_{CC}$  exceeds  $V_{BATT} + 0.03V$ . There is a 60mV hysteresis around this battery switch threshold to prevent oscillations between supplies.

While  $V_{CC}$  is connected to  $V_{OUT}$  the BATT-ON pin is pulled LOW. The signal can drive an external PNP transistor to provide additional current to the external circuits during normal operation.

## Operation

The device is in normal operation with  $V_{CC}$  as long as  $V_{CC} > V_{TRIP1}$ . It switches to the battery backup mode when  $V_{CC}$  goes away.

Condition	Mode of Operation
$V_{CC} > V_{TRIP1}$	Normal Operation
$V_{CC} > V_{TRIP1}$ & $V_{BATT} = 0$	Normal Operation without battery backup capability
$0 \leq V_{CC} \leq V_{TRIP1}$ and $V_{CC} < V_{BATT}$	Battery Backup mode; RESET signal is asserted. No communication to the device is allowed.

## Control Register

The Control Register provides the user a mechanism for changing the Block Lock and Watchdog Timer settings. The Block Lock and Watchdog Timer bits are nonvolatile and do not change when power is removed.

The Control Register is accessed with a special preamble in the slave byte (1011) and is located at address 1FFh. It can only be modified by performing a byte write operation directly to the address of the register and only one data byte is allowed for each register write operation. Prior to writing to the Control Register, the WEL and RWEL bits must be set using a two step process, with the whole sequence requiring 3 steps. See "Writing to the Control Registers" on page 8.

The user must issue a stop, after sending this byte to the register, to initiate the nonvolatile cycle that stores WD1, WDO, PUP1, PUP0, and BP. The X40420 will not acknowledge any data bytes written after the first byte is entered.

The state of the Control Register can be read at any time by performing a random read at address 01Fh, using the special preamble. Only one byte is read by each register read operation. The master should supply a stop condition to be consistent with the bus protocol, but a stop is not required to end this operation.

7	6	5	4	3	2	1	0
PUP1	WD1	WDO	BP	0	RWEL	WEL	PUP0

## RWEL: Register Write Enable Latch (Volatile)

The RWEL bit must be set to "1" prior to a write to the Control Register.

Figure 5. Sample  $V_{TRIP}$  Reset Circuit

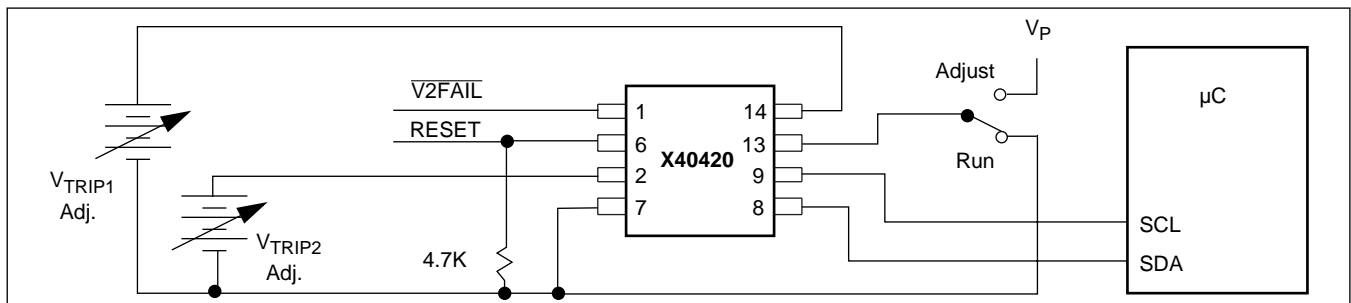

# X40420/X40421 – Preliminary

Figure 6.  $V_{TRIPX}$  Set/Reset Sequence (X = 1, 2)

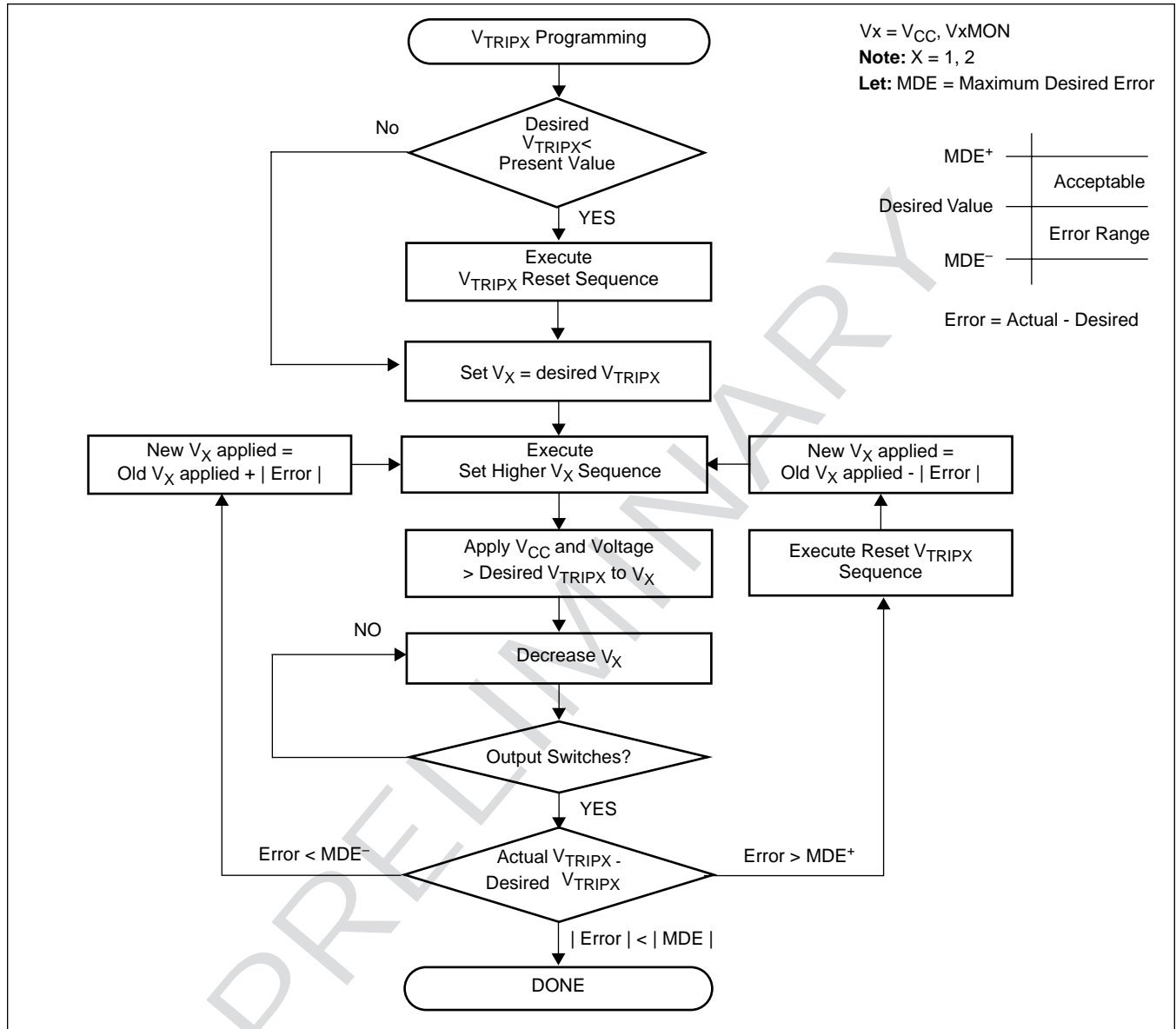

## WEL: Write Enable Latch (Volatile)

The WEL bit controls the access to the memory and to the Register during a write operation. This bit is a volatile latch that powers up in the LOW (disabled) state. While the WEL bit is LOW, writes to any address, including any control registers will be ignored (no acknowledge will be issued after the Data Byte). The WEL bit is set by writing a “1” to the WEL bit and zeroes to the other bits of the control register.

Once set, WEL remains set until either it is reset to 0 (by writing a “0” to the WEL bit and zeroes to the other bits of the control register) or until the part powers up again. Writes to the WEL bit do not cause a high voltage write cycle, so the device is ready for the next operation immediately after the stop condition.

# X40420/X40421 – Preliminary

## BP: Block Protect Bit (Nonvolatile)

The Block Protect Bits BP determines which blocks of the array are write protected. A write to a protected block of memory is ignored. The block protect bit will prevent write operations to half the array segment.

BP	Protected Addresses (Size)	Memory Array Lock
0	None	None
1	100h – 1FFh (256 bytes)	Upper Half of Memory Array

## PUP1, PUP0: Power Up Bits (Nonvolatile)

The Power Up bits, PUP1 and PUP0, determine the  $t_{PURST}$  time delay. The nominal power up times are shown in the following table.

PUP1	PUP0	Power on Reset Delay ( $t_{PURST}$ )
0	0	50ms
0	1	200ms (default)
1	0	400ms
1	1	800ms

## WD1, WD0: Watchdog Timer Bits

The bits WD1 and WD0 control the period of the Watchdog Timer. The options are shown below.

WD1	WD0	Watchdog Time Out Period
0	0	1.4 seconds
0	1	200 milliseconds
1	0	25 milliseconds
1	1	disabled (factory default)

## Writing to the Control Registers

Changing any of the nonvolatile bits of the control and trickle registers requires the following steps:

- Write a 02H to the Control Register to set the Write Enable Latch (WEL). This is a volatile operation, so there is no delay after the write. (Operation preceded by a start and ended with a stop).
- Write a 06H to the Control Register to set the Register Write Enable Latch (RWEL) and the WEL bit. This is also a volatile cycle. The zeros in the data byte are required. (Operation preceded by a start and ended with a stop).

- Write a one byte value to the Control Register that has all the control bits set to the desired state. The Control register can be represented as  $qxys\ 001r$  in binary, where  $xy$  are the WD bits, and  $st$  are the BP bits and  $qr$  are the power up bits. This operation proceeded by a start and ended with a stop bit. Since this is a nonvolatile write cycle it will take up to 10ms to complete. The RWEL bit is reset by this cycle and the sequence must be repeated to change the nonvolatile bits again. If bit 2 is set to '1' in this third step ( $qxys\ 011r$ ) then the RWEL bit is set, but the WD1, WD0, PUP1, PUP0, and BP bits remain unchanged. Writing a second byte to the control register is not allowed. Doing so aborts the write operation and returns a NACK.

- A read operation occurring between any of the previous operations will not interrupt the register write operation.
- The RWEL bit cannot be reset without writing to the nonvolatile control bits in the control register, power cycling the device or attempting a write to a write protected block.

To illustrate, a sequence of writes to the device consisting of [02H, 06H, 02H] will reset all of the nonvolatile bits in the Control Register to 0. A sequence of [02H, 06H, 06H] will leave the nonvolatile bits unchanged and the RWEL bit remains set.

- Note:**
1.  $t_{PURST}$  is set to 200ms as factory default.
  2. Watchdog timer bits are shipped disabled.

## Fault Detection Register (FDR)

The Fault Detection Register provides the user the status of what causes the system reset active. The Manual Reset Fail, Watchdog Timer Fail and Three Low Voltage Fail bits are volatile

7	6	5	4	3	2	1	0
LV1F	LV2F	0	WDF	MRF	0	0	0

The FDR is accessed with a special preamble in the slave byte (1011) and is located at address 0FFh. It can only be modified by performing a byte write operation directly to the address of the register and only one data byte is allowed for each register write operation.

There is no need to set the WEL or RWEL in the control register to access this fault detection register.



# X40420/X40421 – Preliminary

Figure 7. Valid Data Changes on the SDA Bus

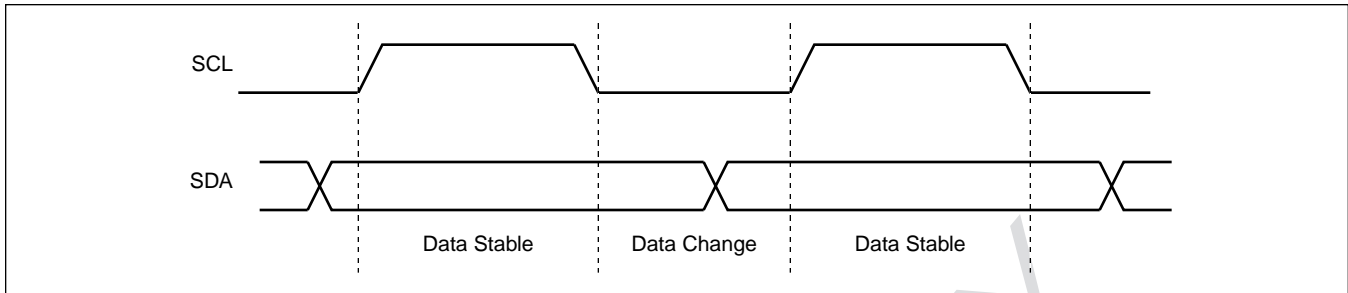

At power-up, the Fault Detection Register is defaulted to all “0”. The system needs to initialize this register to all “1” before the actual monitoring take place. In the event of any one of the monitored sources failed. The corresponding bits in the register will change from a “1” to a “0” to indicate the failure. At this moment, the system should perform a read to the register and noted the cause of the reset. After reading the register the system should reset the register back to all “1” again. The state of the Fault Detection Register can be read at any time by performing a random read at address 0FFh, using the special preamble.

The FDR can be read by performing a random read at 0FFh address of the register at any time. Only one byte of data is read by the register read operation.

### MRF, Manual Reset Fail Bit (Volatile)

The MRF bit will set to “0” when Manual Reset input goes active.

### WDF, Watchdog Timer Fail Bit (Volatile)

The WDF bit will set to “0” when WDO goes active.

### LV1F, Low $V_{CC}$ Reset Fail Bit (Volatile)

The LV1F bit will be set to “0” when  $V_{CC}$  ( $V1MON$ ) falls below  $V_{TRIP1}$ .

### LV2F, Low $V2MON$ Reset Fail Bit (Volatile)

The LV2F bit will be set to “0” when  $V2MON$  falls below  $V_{TRIP2}$ .

### Interface Conventions

The device supports a bidirectional bus oriented protocol. The protocol defines any device that sends data onto the bus as a transmitter, and the receiving device as the receiver. The device controlling the transfer is called the master and the device being controlled is called the slave. The master always initiates data transfers, and provides the clock for both transmit and receive operations. Therefore, the devices in this family operate as slaves in all applications.

### Serial Clock and Data

Data states on the SDA line can change only during SCL LOW. SDA state changes during SCL HIGH are reserved for indicating start and stop conditions. See Figure 7.

### Serial Start Condition

All commands are preceded by the start condition, which is a HIGH to LOW transition of SDA when SCL is HIGH. The device continuously monitors the SDA and SCL lines for the start condition and will not respond to any command until this condition has been met. See Figure 8.

### Serial Stop Condition

All communications must be terminated by a stop condition, which is a LOW to HIGH transition of SDA when SCL is HIGH. The stop condition is also used to place the device into the Standby power mode after a read sequence. A stop condition can only be issued after the transmitting device has released the bus. See Figure 8.

# X40420/X40421 – Preliminary

Figure 8. Valid Start and Stop Conditions

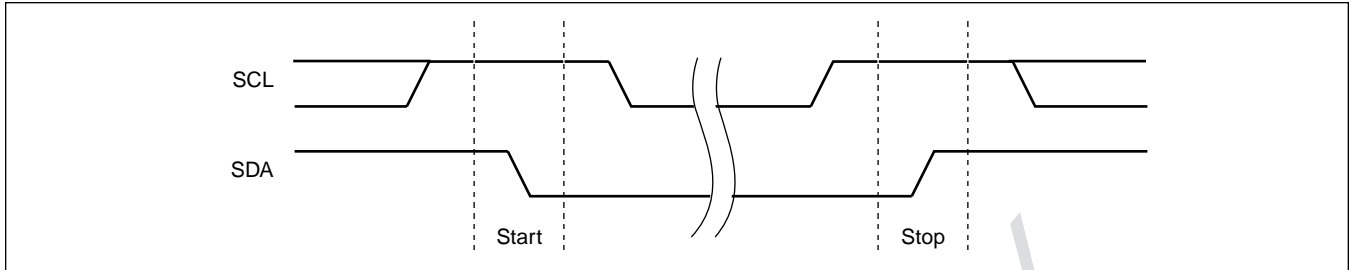

## Serial Acknowledge

Acknowledge is a software convention used to indicate successful data transfer. The transmitting device, either master or slave, will release the bus after transmitting eight bits. During the ninth clock cycle, the receiver will pull the SDA line LOW to acknowledge that it received the eight bits of data. See Figure 9.

The device will respond with an acknowledge after recognition of a start condition and if the correct Device Identifier and Select bits are contained in the Slave Address Byte. If a write operation is selected, the device will respond with an acknowledge after the receipt of each subsequent eight bit word. The device will acknowledge all incoming data and address bytes, except for the Slave Address Byte when the Device Identifier and/or Select bits are incorrect.

In the read mode, the device will transmit eight bits of data, release the SDA line, then monitor the line for an acknowledge. If an acknowledge is detected and no stop condition is generated by the master, the device will continue to transmit data. The device will terminate further data transmissions if an acknowledge is not

detected. The master must then issue a stop condition to return the device to Standby mode and place the device into a known state.

## Serial Write Operations

### Byte Write

For a write operation, the device requires the Slave Address Byte and a Word Address Byte. This gives the master access to any one of the words in the array. After receipt of the Word Address Byte, the device responds with an acknowledge, and awaits the next eight bits of data. After receiving the 8 bits of the Data Byte, the device again responds with an acknowledge. The master then terminates the transfer by generating a stop condition, at which time the device begins the internal write cycle to the nonvolatile memory. During this internal write cycle, the device inputs are disabled, so the device will not respond to any requests from the master. The SDA output is at high impedance. See Figure 12.

A write to a protected block of memory will suppress the acknowledge bit.

Figure 9. Acknowledge Response From Receiver

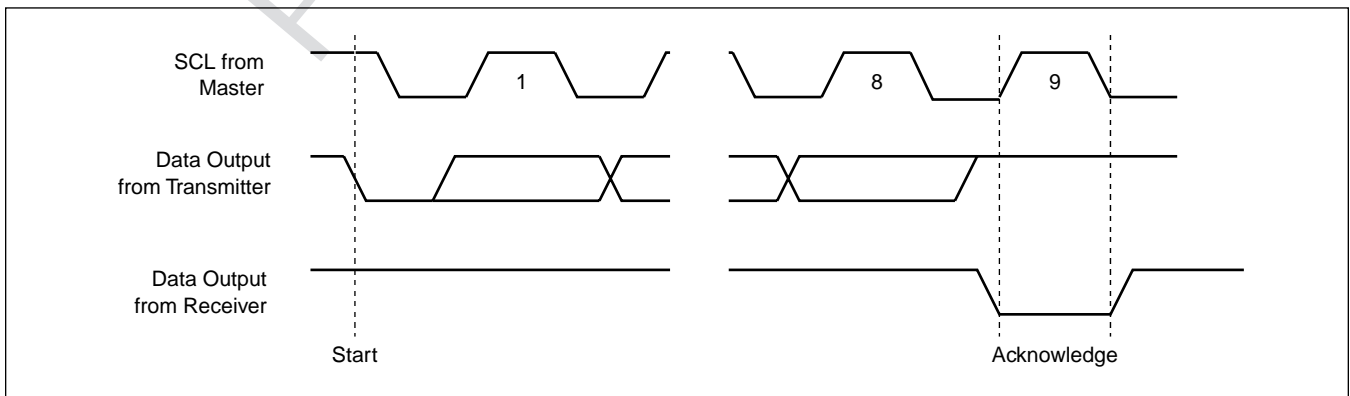

# X40420/X40421 – Preliminary

**Figure 10. Byte Write Sequence**

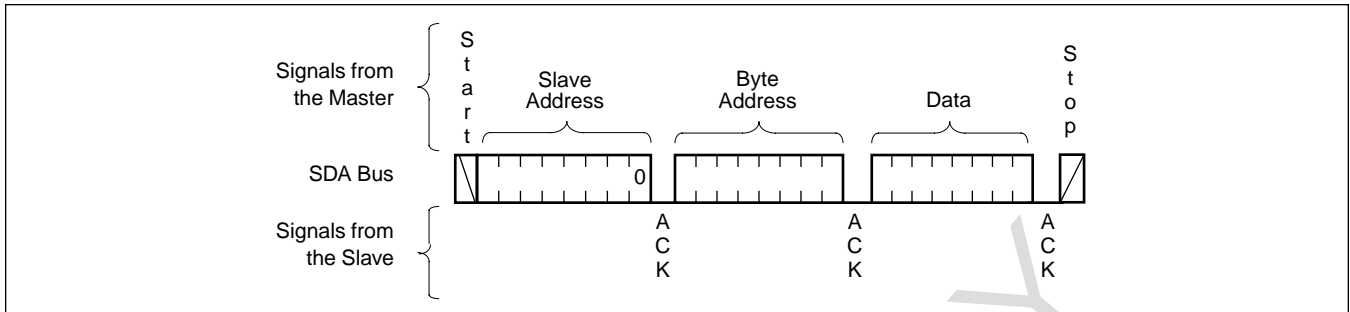

## Page Write

The device is capable of a page write operation. It is initiated in the same manner as the byte write operation; but instead of terminating the write cycle after the first data byte is transferred, the master can transmit an unlimited number of 8-bit bytes. After the receipt of each byte, the device will respond with an acknowledge, and the address is internally incremented by one. The page address remains constant. When the counter reaches the end of the page, it “rolls over” and goes back to ‘0’ on the same page.

This means that the master can write 16 bytes to the page starting at any location on that page. If the master begins writing at location 10, and loads 12 bytes, then the first 6 bytes are written to locations 10 through 15, and the last 6 bytes are written to locations 0 through 5. Afterwards, the address counter would point to location 6 of the page that was just written. If the master supplies more than 16 bytes of data, then new data over-writes the previous data, one byte at a time.

**Figure 11. Page Write Operation**

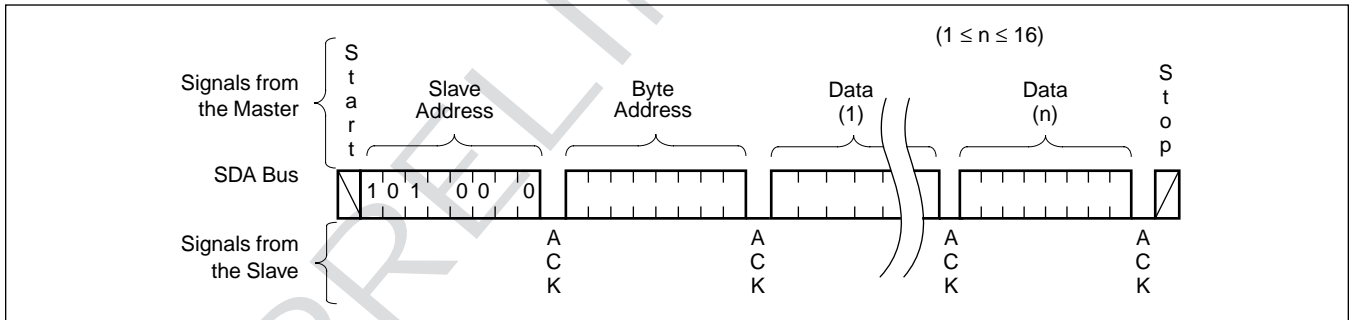

**Figure 12. Writing 12 bytes to a 16-byte page starting at location 10.**

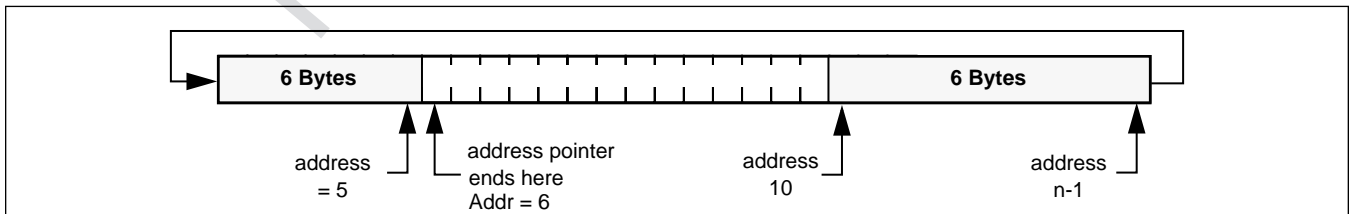

The master terminates the Data Byte loading by issuing a stop condition, which causes the device to begin the nonvolatile write cycle. As with the byte write operation,

all inputs are disabled until completion of the internal write cycle. See Figure 11 for the address, acknowledge, and data transfer sequence.

# X40420/X40421 – Preliminary

## Stops and Write Modes

Stop conditions that terminate write operations must be sent by the master after sending at least 1 full data byte plus the subsequent ACK signal. If a stop is issued in the middle of a data byte, or before 1 full data byte plus its associated ACK is sent, then the device will reset itself without performing the write. The contents of the array will not be effected.

## Acknowledge Polling

The disabling of the inputs during high voltage cycles can be used to take advantage of the typical 5ms write cycle time. Once the stop condition is issued to indicate the end of the master's byte load operation, the device initiates the internal high voltage cycle. Acknowledge polling can be initiated immediately. To do this, the master issues a start condition followed by the Slave Address Byte for a write or read operation. If the device is still busy with the high voltage cycle then no ACK will be returned. If the device has completed the write operation, an ACK will be returned and the host can then proceed with the read or write operation. See Figure 13.

## Serial Read Operations

Read operations are initiated in the same manner as write operations with the exception that the  $R/\overline{W}$  bit of the Slave Address Byte is set to one. There are three basic read operations: Current Address Reads, Random Reads, and Sequential Reads.

### Current Address Read

Internally the device contains an address counter that maintains the address of the last word read incremented by one. Therefore, if the last read was to address  $n$ , the next read operation would access data from address  $n+1$ . On power up, the address of the address counter is undefined, requiring a read or write operation for initialization.

Upon receipt of the Slave Address Byte with the  $R/\overline{W}$  bit set to one, the device issues an acknowledge and then transmits the eight bits of the Data Byte. The master terminates the read operation when it does not respond with an acknowledge during the ninth clock and then issues a stop condition. See Figure 14 for the address, acknowledge, and data transfer sequence.

Figure 13. Acknowledge Polling Sequence

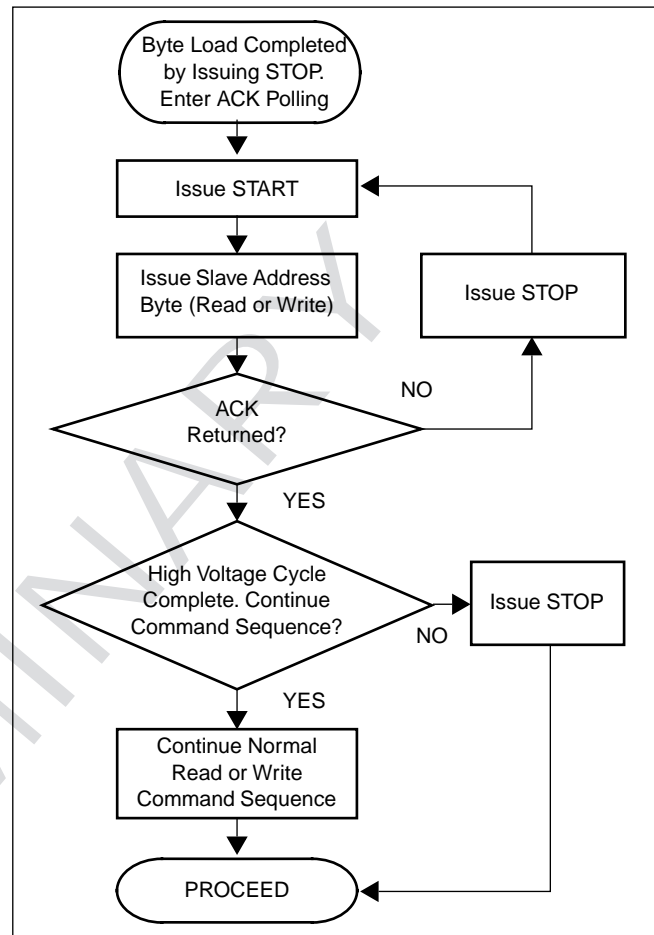

It should be noted that the ninth clock cycle of the read operation is not a “don't care.” To terminate a read operation, the master must either issue a stop condition during the ninth cycle or hold SDA HIGH during the ninth clock cycle and then issue a stop condition.

### Random Read

Random read operation allows the master to access any memory location in the array. Prior to issuing the Slave Address Byte with the  $R/\overline{W}$  bit set to one, the master must first perform a “dummy” write operation. The master issues the start condition and the Slave Address Byte, receives an acknowledge, then issues the Word Address Bytes. After acknowledging receipts of the Word Address Bytes, the master immediately issues another start condition and the Slave Address Byte with the  $R/\overline{W}$  bit set to one. This is followed by an acknowledge from the device and then by the eight bit word. The master terminates the read operation by not responding with an acknowledge and then issuing a stop condition. See Figure 15 for the address, acknowledge, and data transfer sequence.

# X40420/X40421 – Preliminary

A similar operation called “Set Current Address” where the device will perform this operation if a stop is issued instead of the second start shown in Figure 15. The device will go into standby mode after the stop and all bus activity will be ignored until a start is detected. This operation loads the new address into the address counter. The next Current Address Read operation will read from the newly loaded address. This operation could be useful if the master knows the next address it needs to read, but is not ready for the data.

## Sequential Read

Sequential reads can be initiated as either a current address read or random address read. The first Data Byte is transmitted as with the other modes; however, the master now responds with an acknowledge, indicating it requires additional data. The device continues to output data for each acknowledge received. The master terminates the read operation by not responding with an acknowledge and then issuing a stop condition.

The data output is sequential, with the data from address n followed by the data from address n + 1. The address counter for read operations increments through all page and column addresses, allowing the entire memory contents to be serially read during one operation. At the end of the address space the counter “rolls over” to address 0000<sub>H</sub> and the device continues to output data for each acknowledge received. See Figure 17 for the acknowledge and data transfer sequence.

## SERIAL DEVICE ADDRESSING

### Memory Address Map

CR, Control Register, CR7: CR0  
Address: 1FF<sub>hex</sub>

FDR, Fault Detection Register, FDR7: FDR0  
Address: 0FF<sub>hex</sub>

General Purpose Memory Organization, A8:A0  
Address: 00h to 1FFh

### General Purpose Memory Array Configuration

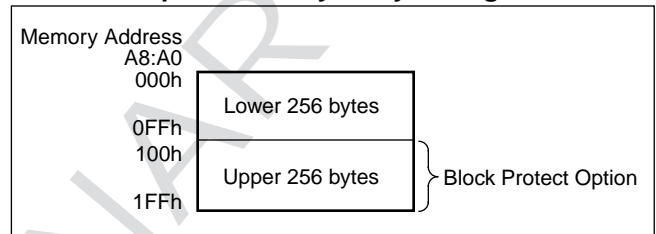

### Slave Address Byte

Following a start condition, the master must output a Slave Address Byte. This byte consists of several parts:

- a device type identifier that is always “1010” when accessing the array and “1011” when accessing the control register and fault detection register.
- two bits of “0”.
- one bit that becomes the MSB of the memory address X<sub>4</sub>.
- last bit of the slave command byte is a R/W bit. The R/W bit of the Slave Address Byte defines the operation to be performed. When the R/W bit is a one, then a read operation is selected. A zero selects a write operation. See Figure 16.

Figure 14. Current Address Read Sequence

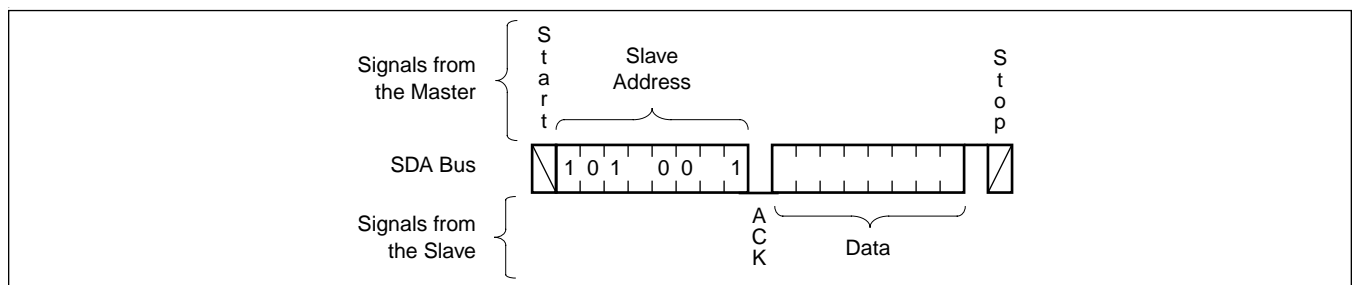

# X40420/X40421 – Preliminary

**Figure 15. Random Address Read Sequence**

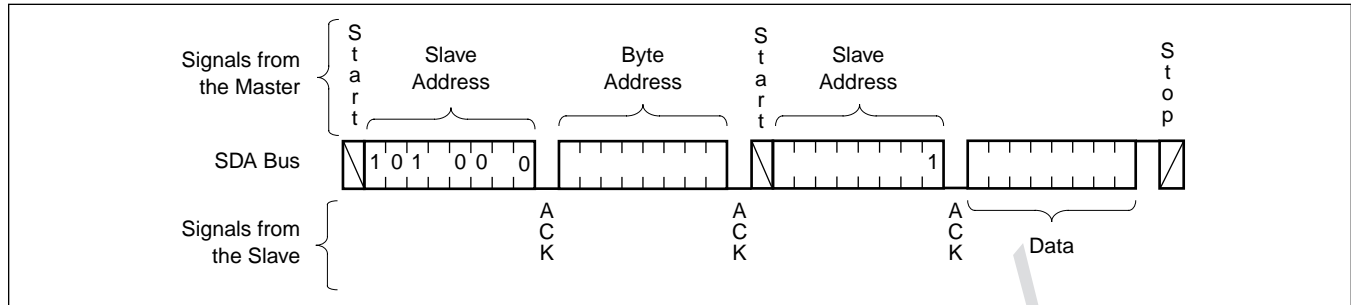

**Figure 16. X40410/11 Addressing**

Slave Byte	
General Purpose Memory	1 0 1 0 0 0 A8 R/W
Control Register	1 0 1 1 0 0 1 R/W
Fault Detection Register	1 0 1 1 0 0 0 R/W

Word Address	
General Purpose Memory	A7 A6 A5 A4 A3 A2 A1 A0
Control Register	1 1 1 1 1 1 1 1
Fault Detection Register	1 1 1 1 1 1 1 1

### Word Address

The word address is either supplied by the master or obtained from an internal counter.

### Operational Notes

The device powers-up in the following state:

- The device is in the low power standby state.
- The WEL bit is set to '0'. In this state it is not possible to write to the device.
- SDA pin is the input mode.
- RESET/RESET Signal is active for  $t_{PURST}$ .

### Data Protection

The following circuitry has been included to prevent inadvertent writes:

- The WEL bit must be set to allow write operations.
- The proper clock count and bit sequence is required prior to the stop bit in order to start a nonvolatile write cycle.
- A three step sequence is required before writing into the Control Register to change Watchdog Timer or Block Lock settings.
- The WP pin, when held HIGH, prevents all writes to the array and all the Register.

**Figure 17. Sequential Read Sequence**

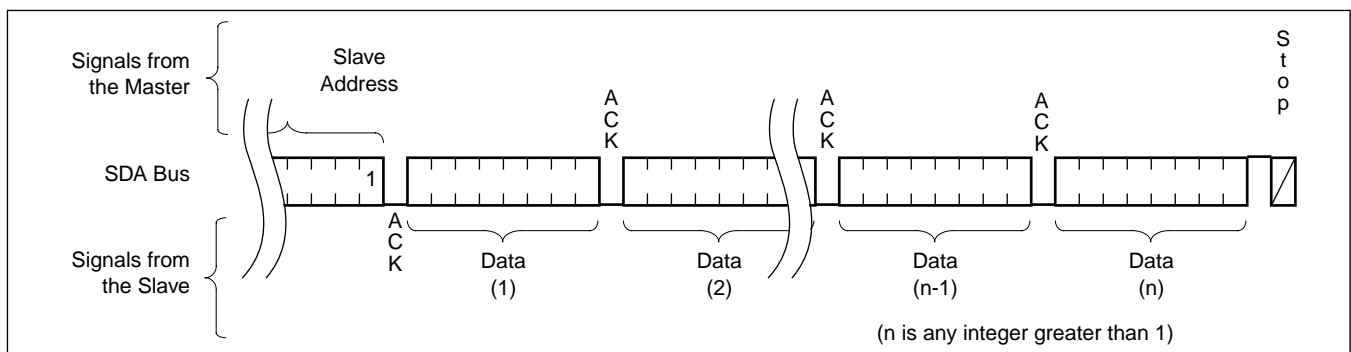

# X40420/X40421 – Preliminary

## ABSOLUTE MAXIMUM RATINGS

Temperature under bias ..... –65°C to +135°C  
 Storage temperature ..... –65°C to +150°C  
 Voltage on any pin with respect to  $V_{SS}$  ..... –1.0V to +7V  
 D.C. output current ..... 5mA  
 Lead temperature (soldering, 10 seconds)..... 300°C

## COMMENT

Stresses above those listed under “Absolute Maximum Ratings” may cause permanent damage to the device. This is a stress rating only; functional operation of the device (at these or any other conditions above those listed in the operational sections of this specification) is not implied. Exposure to absolute maximum rating conditions for extended periods may affect device reliability.

## RECOMMENDED OPERATING CONDITIONS

Temperature	Min.	Max.
Commercial	0°C	70°C
Industrial	–40°C	+85°C

Version	Chip Supply Voltage	Monitored Voltages*
-A or -B	2.7V to 5.5V	2.6 to 5.5V
-C	2.7V to 5.5V	1.6V to 3.6V

\*See ordering Info

## D.C. OPERATING CHARACTERISTICS

(Over the recommended operating conditions unless otherwise specified)

Symbol	Parameter	Min.	Typ. <sup>(5)</sup>	Max.	Unit	Test Conditions
$I_{CC1}^{(1)}$	Active Supply Current ( $V_{CC}$ ) Read (Excludes $I_{OUT}$ )			1.5	mA	$V_{IL} = V_{CC} \times 0.1$ $V_{IH} = V_{CC} \times 0.9$ , $f_{SCL} = 400\text{kHz}$
$I_{CC2}^{(1)}$	Active Supply Current ( $V_{CC}$ ) Write Non Volatile Memory (Excludes $I_{OUT}$ )			3.0	mA	
$I_{SB1}^{(1)(7)}$	Standby Current ( $V_{CC}$ ) AC (WDT off)		6	10	$\mu\text{A}$	$V_{IL} = V_{CC} \times 0.1$ $V_{IH} = V_{CC} \times 0.9$ $f_{SCL}, f_{SDA} = 400\text{kHz}$
$I_{SB2}^{(2)(7)}$	Standby Current ( $V_{CC}$ ) DC (WDT on)		25	30	$\mu\text{A}$	$V_{SDA} = V_{SCL} = V_{CC}$ Others = GND or $V_{CC}$
$I_{BATT1}^{(3)(7)}$	$V_{BATT}$ Current (Excludes $I_{OUT}$ )		0.4	1	$\mu\text{A}$	$V_{OUT} = V_{CC}$
$I_{BATT2}^{(7)}$	$V_{BATT}$ Current (Excludes $I_{OUT}$ ) (Battery Backup Mode)			6	$\mu\text{A}$	$V_{BATT} = 2.8\text{V}$ $V_{OUT} = \text{Open}$
$V_{OUT1}^{(7)}$	Output Voltage ( $V_{CC} > V_{BATT} + 0.03\text{V}$ or $V_{CC} > V_{TRIP1}$ )	$V_{CC} - 0.05\text{V}$ $V_{CC} - 0.5\text{V}$			V	$I_{OUT} = 5\text{mA}$ (4.5–5.5V) $I_{OUT} = 50\text{mA}$ (4.5–5.5V)
$V_{OUT2}^{(7)}$	Output Voltage ( $V_{CC} < V_{BATT} - 0.03\text{V}$ and $V_{CC} < V_{TRIP1}$ ) {Battery Backup}	$V_{BATT} - 0.2$			V	$I_{OUT} = 250\mu\text{A}$
$V_{OLB}$	Output (BATT-ON) LOW Voltage			0.4	V	$I_{OL} = 3.0\text{mA}$ (4.5–5.5V)
$V_{OHB}$	Output (BATT-ON) HIGH Voltage	$V_{OUT} - 0.8$			V	$I_{OH} = -0.4\text{mA}$ (4.5–5.5V)
$V_{BSH}^{(7)}$	Battery Switch Hysteresis ( $V_{CC} < V_{TRIP1}$ )		30 -30		mV	Power Up Power Down
$I_{LI}$	Input Leakage Current (SCL, $\overline{\text{MR}}$ , WP)			10	$\mu\text{A}$	$V_{IL} = \text{GND to } V_{CC}$
$I_{LO}$	Output Leakage Current (SDA, $\overline{\text{V2FAIL}}$ , WDO, RESET)			10	$\mu\text{A}$	$V_{SDA} = \text{GND to } V_{CC}$ Device is in Standby <sup>(2)</sup>
$V_{IL}^{(3)}$	Input LOW Voltage (SDA, SCL, $\overline{\text{MR}}$ , WP)	-0.5		$V_{CC} \times 0.3$	V	
$V_{IH}^{(3)}$	Input HIGH Voltage (SDA, SCL, $\overline{\text{MR}}$ , WP)	$V_{CC} \times 0.7$		$V_{CC} + 0.5$	V	

# X40420/X40421 – Preliminary

## D.C. OPERATING CHARACTERISTICS (Continued)

(Over the recommended operating conditions unless otherwise specified)

Symbol	Parameter	Min.	Typ. <sup>(5)</sup>	Max.	Unit	Test Conditions
$V_{HYS}^{(7)}$	Schmitt Trigger Input Hysteresis • Fixed input level • $V_{CC}$ related level	0.2 .05 x $V_{CC}$			V V	
$V_{OL}$	Output LOW Voltage (SDA, RESET/ RESET, LOWLINE, V2FAIL, WDO)			0.4	V	$I_{OL} = 3.0\text{mA}$ (2.7–5.5V) $I_{OL} = 1.8\text{mA}$ (2.4–3.6V)
<b>V<sub>CC</sub> Supply</b>						
$V_{TRIP1}^{(6)}$	$V_{CC}$ Reset Trip Point Voltage Range	2.0		4.75	V	
		4.55	4.6	4.65		A, B Version
		2.85	2.9	2.95		C Version
$t_{RPDL}^{(7)}$	$V_{TRIP1}$ to $\overline{LOWLINE}$			5	$\mu\text{S}$	
<b>Second Supply Monitor</b>						
$V_{TRIP2}^{(6)}$	V2MON Reset Trip Point Voltage Range	0.9		3.5	V	
		2.85	2.9	2.95		A Version
		2.55	2.6	2.65		B Version
		1.55	1.6	1.65		C Version
$t_{RPD2}^{(7)}$	$V_{TRIP2}$ to $\overline{V2FAIL}$			5	$\mu\text{S}$	

- Notes:** (1) The device enters the Active state after any start, and remains active until: 9 clock cycles later if the Device Select Bits in the Slave Address Byte are incorrect; 200ns after a stop ending a read operation; or  $t_{WC}$  after a stop ending a write operation.  
 (2) The device goes into Standby: 200ns after any stop, except those that initiate a high voltage write cycle;  $t_{WC}$  after a stop that initiates a high voltage cycle; or 9 clock cycles after any start that is not followed by the correct Device Select Bits in the Slave Address Byte.  
 (3) Negative numbers indicate charging current, positive numbers indicate discharge current.  
 (4)  $V_{IL}$  Min. and  $V_{IH}$  Max. are for reference only and are not tested.  
 (5) At 25°C,  $V_{CC} = 3\text{V}$ .  
 (6) See ordering information for standard programming levels. For custom programming levels, contact factory.  
 (7) Based on characterization data only.

### EQUIVALENT INPUT CIRCUIT FOR $V_x\text{MON}$ ( $x = 1, 2$ )

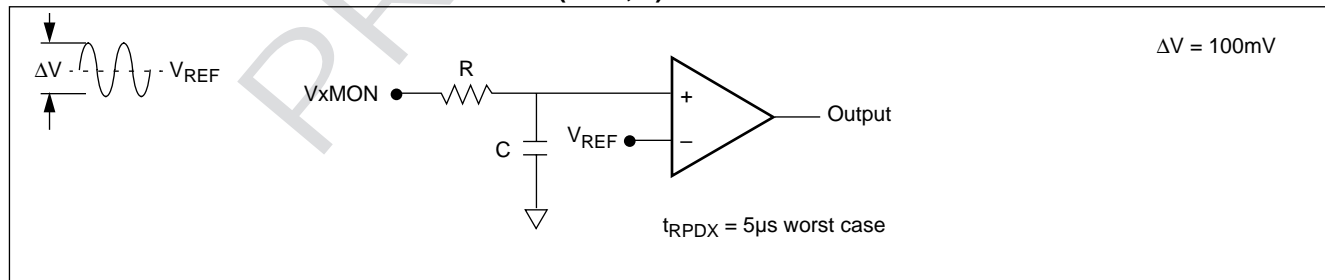



# X40420/X40421 – Preliminary

## CAPACITANCE

Symbol	Parameter	Max.	Unit	Test Conditions
$C_{OUT}^{(1)}$	Output Capacitance (SDA, RESET, $\overline{\text{RESET/LOWLINE}}$ , $\overline{\text{V2FAIL}}$ , WDO)	8	pF	$V_{OUT} = 0V$
$C_{IN}^{(1)}$	Input Capacitance (SCL, WP)	6	pF	$V_{IN} = 0V$

Note: (1) This parameter is not 100% tested.

## EQUIVALENT A.C. OUTPUT LOAD CIRCUIT FOR $V_{CC} = 5V$

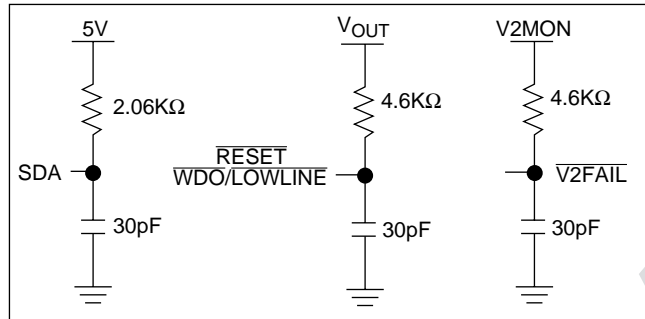

## A.C. TEST CONDITIONS

Input pulse levels	$V_{CC} \times 0.1$ to $V_{CC} \times 0.9$
Input rise and fall times	10ns
Input and output timing levels	$V_{CC} \times 0.5$
Output load	Standard output load

## SYMBOL TABLE

WAVEFORM	INPUTS	OUTPUTS
	Must be steady	Will be steady
	May change from LOW	Will change from LOW to HIGH
	May change from HIGH to LOW	Will change from HIGH to LOW
	Don't Care: Changes Allowed	Changing: State Not Known
	N/A	Center Line is High Impedance

# X40420/X40421 – Preliminary

## A.C. CHARACTERISTICS

Symbol	Parameter	400kHz		Unit
		Min.	Max.	
$f_{SCL}$	SCL Clock Frequency		400	kHz
$t_{IN}$	Pulse width Suppression Time at inputs	50		ns
$t_{AA}$	SCL LOW to SDA Data Out Valid	0.1	0.9	$\mu$ s
$t_{BUF}$	Time the bus free before start of new transmission	1.3		$\mu$ s
$t_{LOW}$	Clock LOW Time	1.3		$\mu$ s
$t_{HIGH}$	Clock HIGH Time	0.6		$\mu$ s
$t_{SU:STA}$	Start Condition Setup Time	0.6		$\mu$ s
$t_{HD:STA}$	Start Condition Hold Time	0.6		$\mu$ s
$t_{SU:DAT}$	Data In Setup Time	100		ns
$t_{HD:DAT}$	Data In Hold Time	0		$\mu$ s
$t_{SU:STO}$	Stop Condition Setup Time	0.6		$\mu$ s
$t_{DH}$	Data Output Hold Time	50		ns
$t_R$	SDA and SCL Rise Time	$20 + 1Cb^{(1)}$	300	ns
$t_F$	SDA and SCL Fall Time	$20 + 1Cb^{(1)}$	300	ns
$t_{SU:WP}$	$\overline{WP}$ Setup Time	0.6		$\mu$ s
$t_{HD:WP}$	$\overline{WP}$ Hold Time	0		$\mu$ s
$C_b$	Capacitive load for each bus line		400	pF

Note: (1)  $C_b$  = total capacitance of one bus line in pF.

## TIMING DIAGRAMS

### Bus Timing

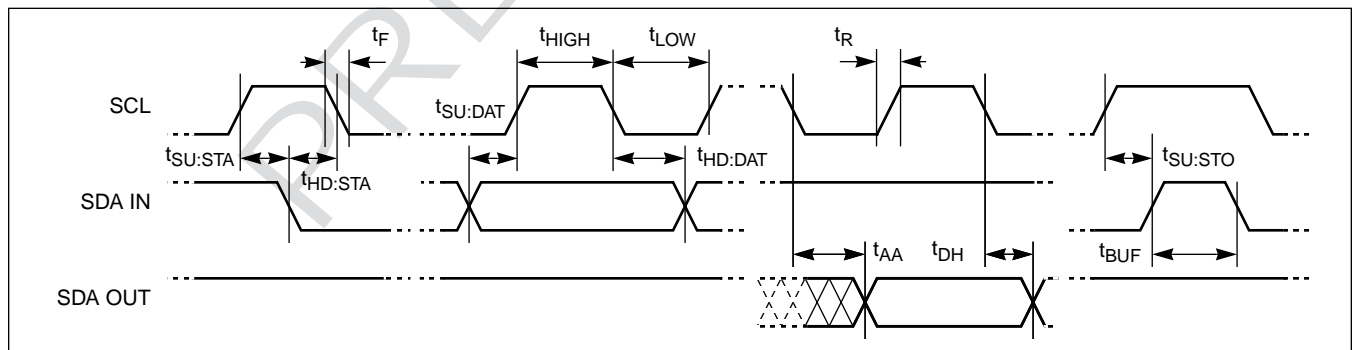

# X40420/X40421 – Preliminary

## WP Pin Timing

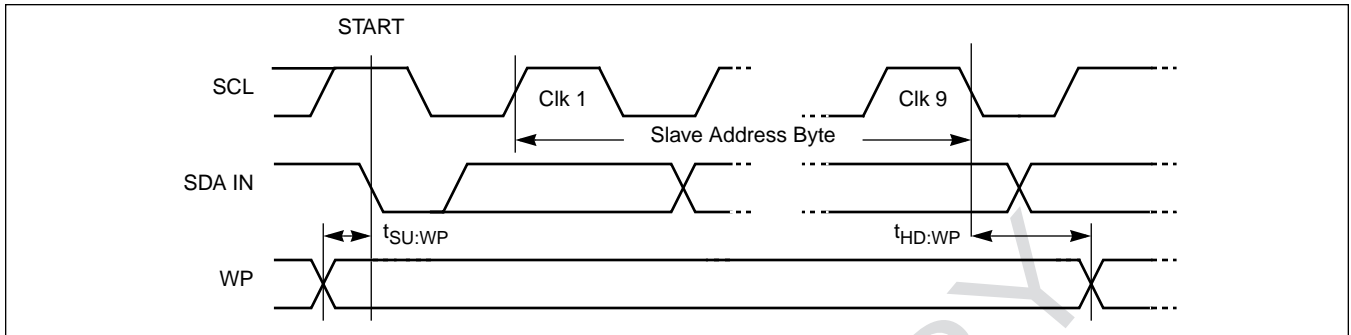

## Write Cycle Timing

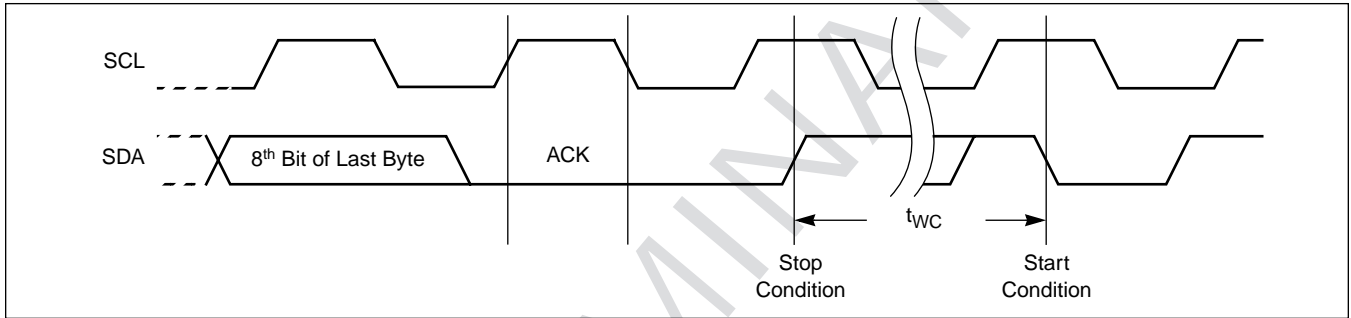

## Nonvolatile Write Cycle Timing

Symbol	Parameter	Min.	Typ. <sup>(1)</sup>	Max.	Unit
$t_{WC}^{(1)}$	Write Cycle Time		5	10	ms

**Note:** (1)  $t_{WC}$  is the time from a valid stop condition at the end of a write sequence to the end of the self-timed internal nonvolatile write cycle. It is the minimum cycle time to be allowed for any nonvolatile write by the user, unless Acknowledge Polling is used.

## Power Fail Timings

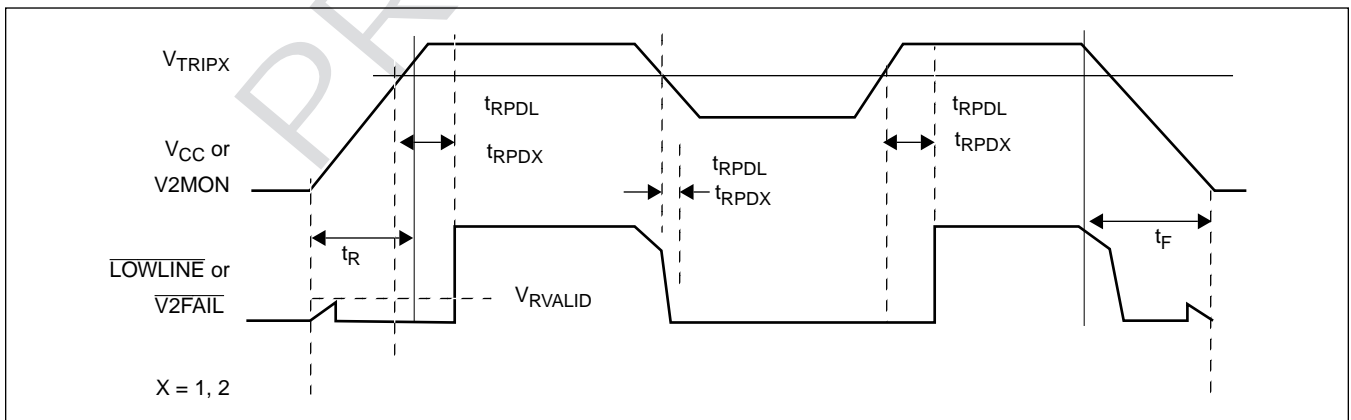

# X40420/X40421 – Preliminary

## RESET/RESETE/MR Timings

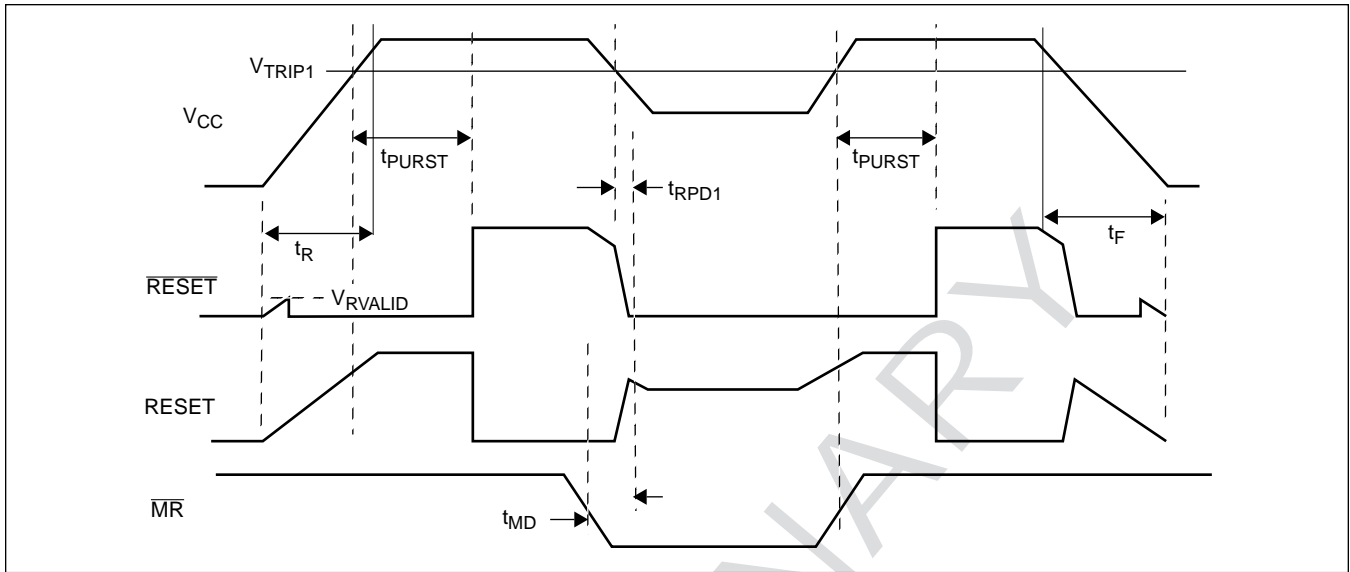

## LOW VOLTAGE AND WATCHDOG TIMINGS PARAMETERS (@25°C, VCC = 5V)

Symbol	Parameters	Min.	Typ.	Max.	Unit
t <sub>RPD1</sub> <sup>(1)</sup>	V <sub>TRIP1</sub> to $\overline{\text{RESET}}/\text{RESETE}$ (Power down only)			5	μs
t <sub>RPDL</sub>	V <sub>TRIP1</sub> to LOWLINE				
t <sub>LR</sub> <sup>(1)</sup>	LOWLINE to $\overline{\text{RESET}}/\text{RESETE}$ delay (Power down only) [= t <sub>RPD1</sub> -t <sub>RPDL</sub> ]		500		ns
t <sub>RPD2</sub> <sup>(1)</sup>	V <sub>TRIP2</sub> to $\overline{\text{V2FAIL}}$			5	μs
t <sub>PURST</sub>	Power On Reset delay: PUP1=0, PUP0=0 PUP1=0, PUP0=1 (factory default) PUP1=1, PUP0=0 PUP1=1, PUP0=1		50 <sup>(1)</sup> 200 400 <sup>(1)</sup> 800 <sup>(1)</sup>		ms ms ms ms
t <sub>F</sub>	V <sub>CC</sub> , V2MON Fall Time	20			mV/μs
t <sub>R</sub>	V <sub>CC</sub> , V2MON Rise Time	20			mV/μs
V <sub>RVALID</sub>	Reset Valid V <sub>CC</sub>	1			V
t <sub>MD</sub>	$\overline{\text{MR}}$ to $\overline{\text{RESET}}/\text{RESETE}$ delay (activation only)	500			ns
t <sub>in1</sub>	Pulse width Suppression Time for $\overline{\text{MR}}$	50			ns
t <sub>WDO</sub>	Watchdog Timer Period: WD1=0, WD0=0 WD1=0, WD0=1 WD1=1, WD0=0 WD1=1, WD0=1 (factory default)		1.4 <sup>(1)</sup> 200 <sup>(1)</sup> 25 OFF		s ms ms
t <sub>RST1</sub>	Watchdog Reset Time Out Delay WD1=0, WD0=0 WD1=0, WD0=1	100	200	300	ms
t <sub>RST2</sub>	Watchdog Reset Time Out Delay WD1=1, WD0=0	12.5	25	37.5	ms
t <sub>RSP</sub>	Watchdog timer restart pulse width	1			μs

Note: (1) Based on characterization data.

# X40420/X40421 – Preliminary

## Watchdog Time Out For 2-Wire Interface

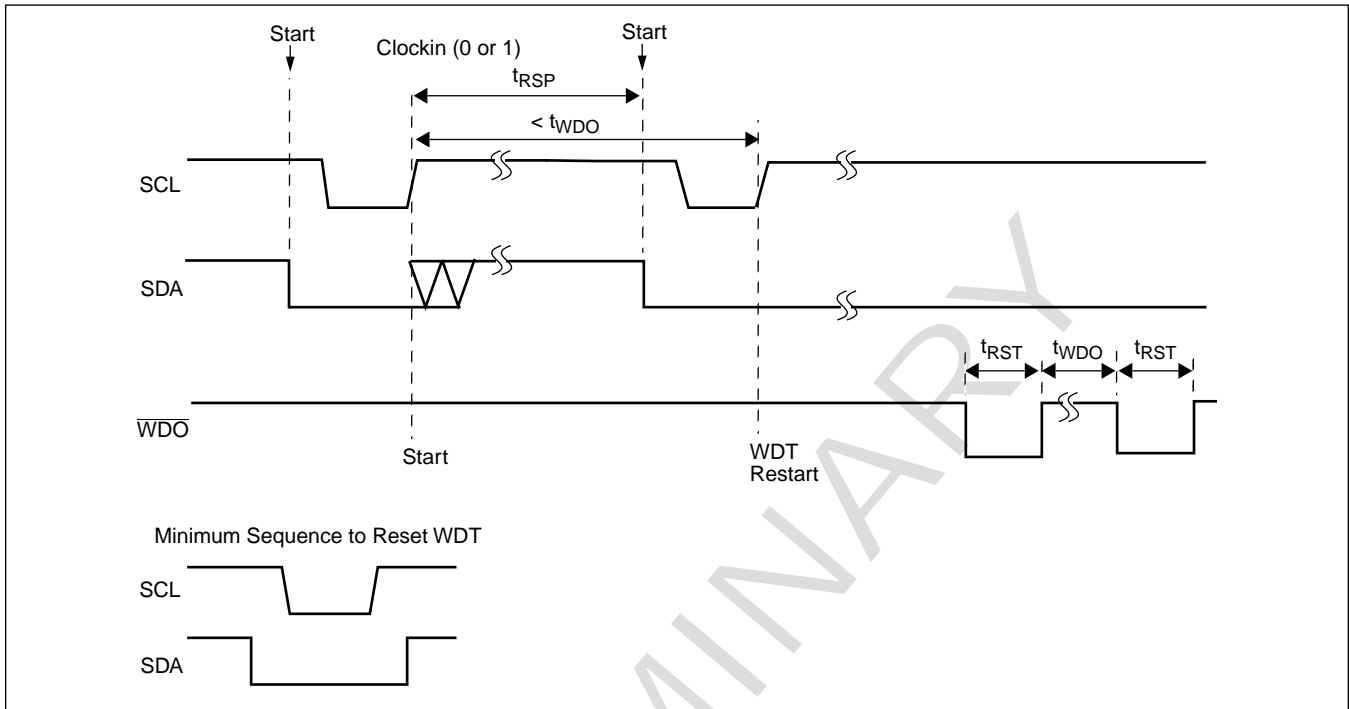

## V<sub>TRIPX</sub> Set/Reset Conditions

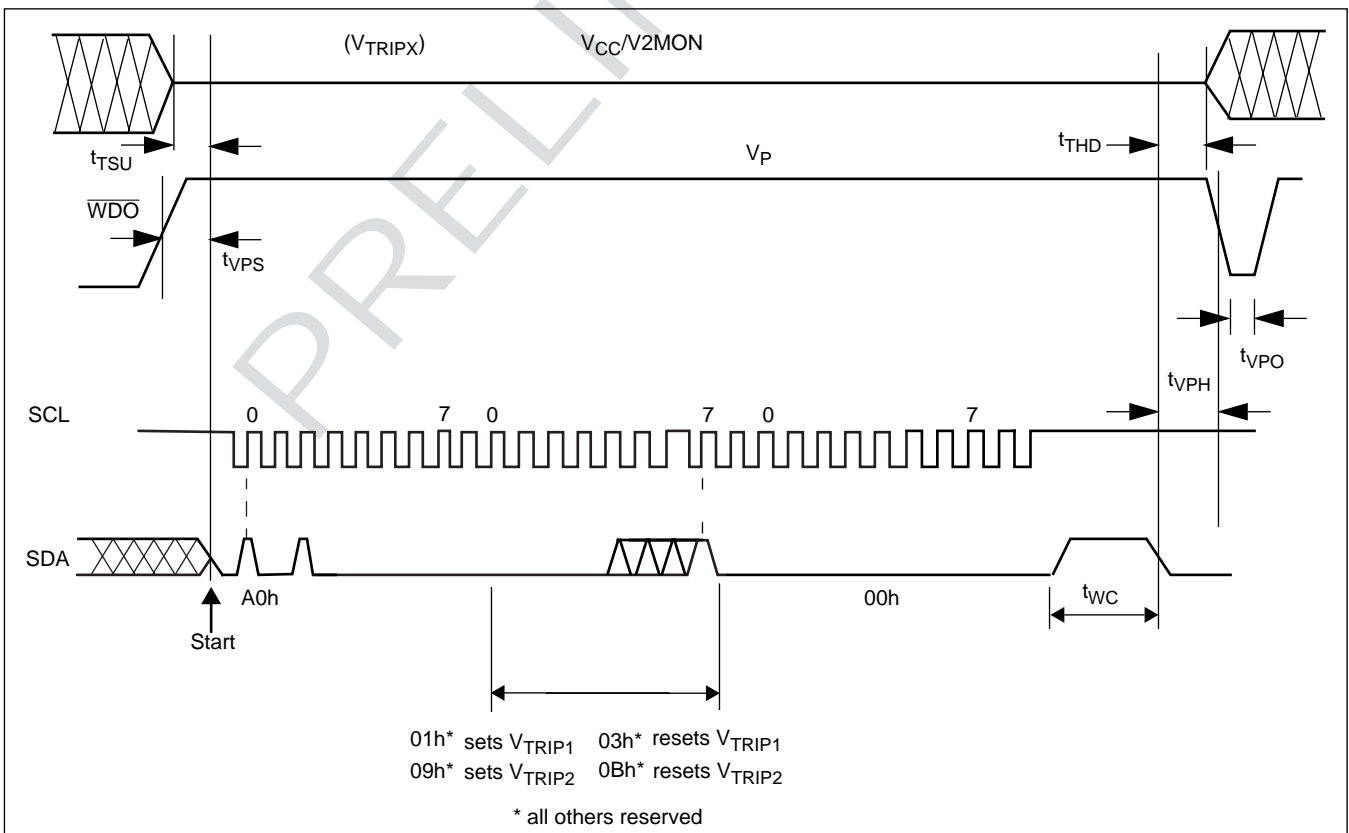

## X40420/X40421 – Preliminary

$V_{TRIP1}$ ,  $V_{TRIP2}$  Programming Specifications:  $V_{CC} = 2.0\text{--}5.5\text{V}$ ; Temperature =  $25^\circ\text{C}$

Parameter	Description	Min.	Max.	Unit
$t_{VPS}$	$\overline{WDO}$ Program Voltage Setup time	10		$\mu\text{s}$
$t_{VPH}$	$\overline{WDO}$ Program Voltage Hold time	10		$\mu\text{s}$
$t_{TSU}$	$V_{TRIPX}$ Level Setup time	10		$\mu\text{s}$
$t_{THD}$	$V_{TRIPX}$ Level Hold (stable) time	10		$\mu\text{s}$
$t_{WC}$	$V_{TRIPX}$ Program Cycle	10		ms
$t_{VPO}$	Program Voltage Off time before next cycle	1		ms
$V_P$	Programming Voltage	15	18	V
$V_{TRAN1}$	$V_{TRIP1}$ Set Voltage Range	2.0	4.75	V
$V_{TRAN2}$	$V_{TRIP2}$ Set Voltage Range	0.9	3.5	V
$V_{TV}$	$V_{TRIPX}$ Set Voltage variation after programming (0-75°C).	-25	+25	mV
$t_{VPS}$	$\overline{WDO}$ Program Voltage Setup time	10		$\mu\text{s}$

$V_{TRIPX}$  programming parameters are periodically sampled and are not 100% tested.

# X40420/X40421 – Preliminary

## PACKAGING INFORMATION

### 14-Lead Plastic Small Outline Gullwing Package Type S

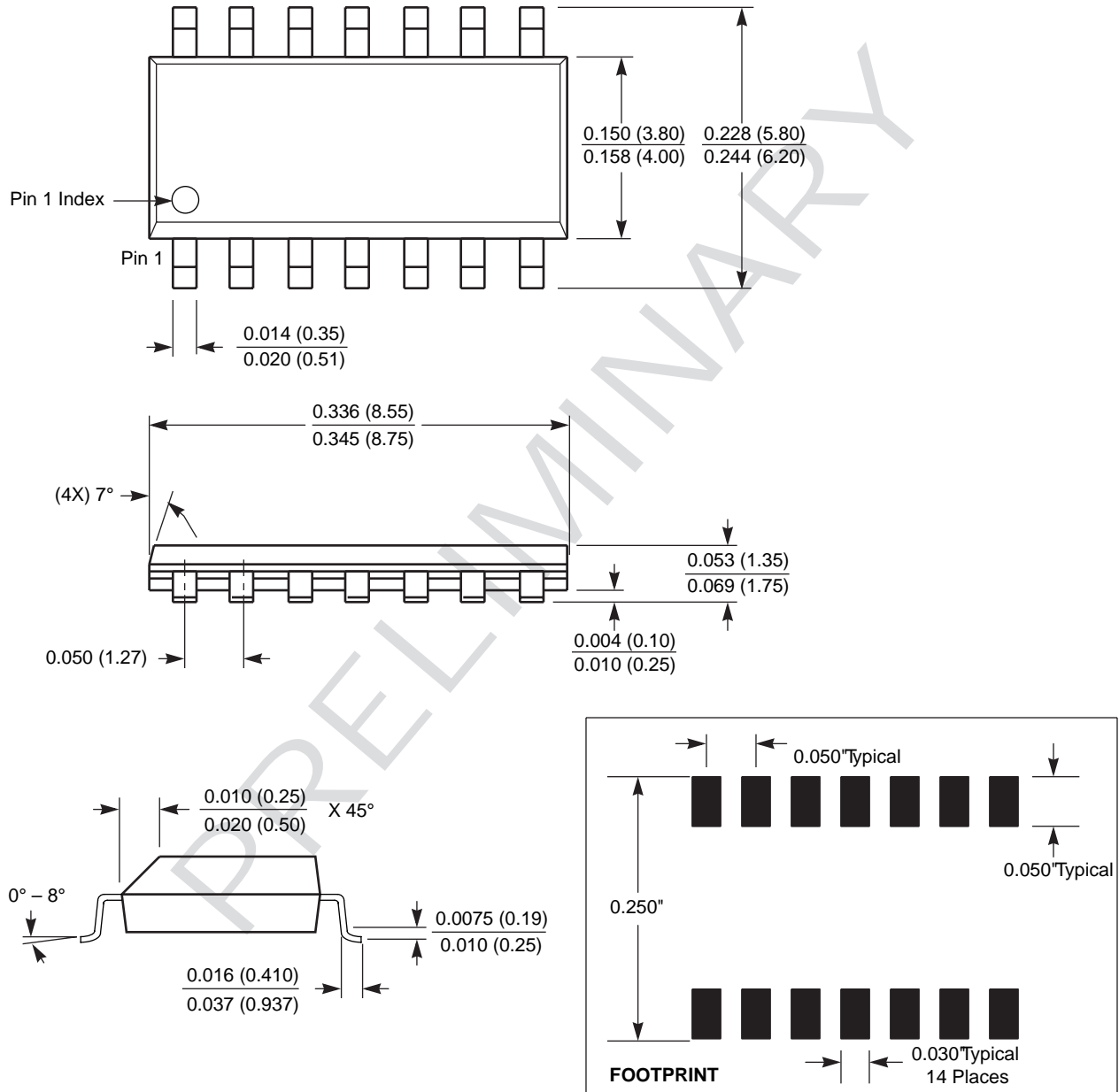

NOTE: ALL DIMENSIONS IN INCHES (IN PARENTHESES IN MILLIMETERS)

# X40420/X40421 – Preliminary

## PACKAGING INFORMATION

### 14-Lead Plastic, TSSOP, Package Type V

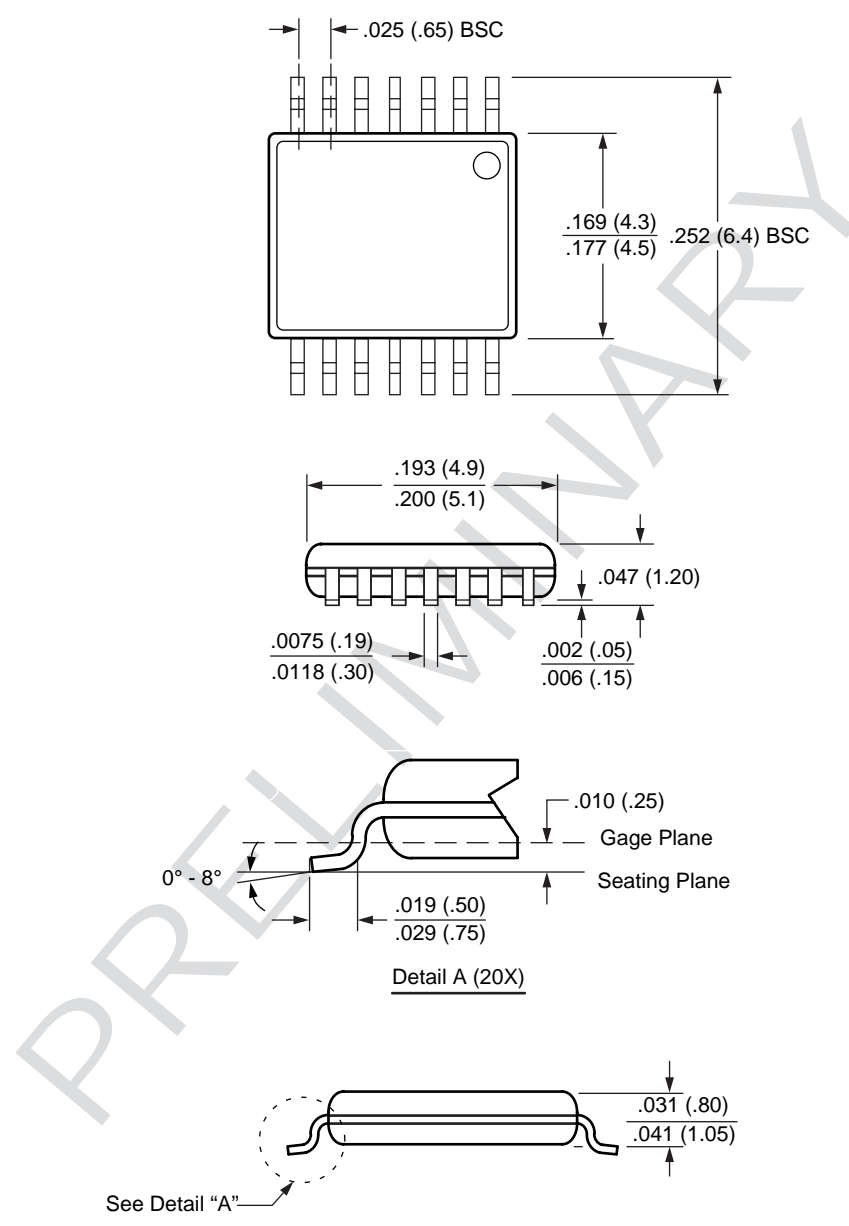

NOTE: ALL DIMENSIONS IN INCHES (IN PARENTHESES IN MILLIMETERS)



# X40420/X40421 – Preliminary

## ORDERING INFORMATION

Monitored V <sub>CC</sub> Supplies	V <sub>TRIP1</sub> Range	V <sub>TRIP2</sub> Range	Package	Operating Temperature Range	Part Number with RESET	Part Number with RESET
2.9-5.5	4.6V±50mV	2.9V±50mV	14L SOIC	0°C - 70°C	X40420S14-A	X40421S14-A
				-40°C - 85°C	X40420S14I-A	X40421S14I-A
			14L TSSOP	0°C - 70°C	X40420V14-A	X40421V14-A
				-40°C - 85°C	X40420V14I-A	X40421V14I-A
2.6-5.5	4.6V±50mV	2.6V±50mV	14L SOIC	0°C - 70°C	X40420S14-B	X40421S14-B
				-40°C - 85°C	X40420S14I-B	X40421S14I-B
			14L TSSOP	0°C - 70°C	X40420V14-B	X40421V14-B
				-40°C - 85°C	X40420V14I-B	X40421V14I-B
1.6-3.6	2.9V±50mV	1.6V±50mV	14L SOIC	0°C - 70°C	X40420S14-C	X40421S14-C
				-40°C - 85°C	X40420S14I-C	X40421S14I-C
			14L TSSOP	0°C - 70°C	X40420V14-C	X40421V14-C
				-40°C - 85°C	X40420V14I-C	X40421V14I-C

## PART MARK INFORMATION

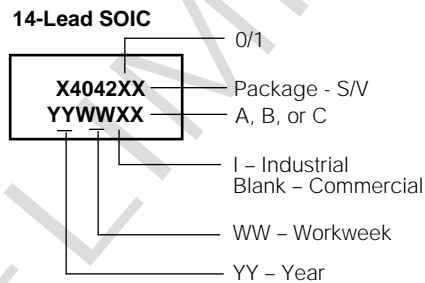

### LIMITED WARRANTY

©Xicor, Inc. 2001 Patents Pending

Devices sold by Xicor, Inc. are covered by the warranty and patent indemnification provisions appearing in its Terms of Sale only. Xicor, Inc. makes no warranty, express, statutory, implied, or by description regarding the information set forth herein or regarding the freedom of the described devices from patent infringement. Xicor, Inc. makes no warranty of merchantability or fitness for any purpose. Xicor, Inc. reserves the right to discontinue production and change specifications and prices at any time and without notice.

Xicor, Inc. assumes no responsibility for the use of any circuitry other than circuitry embodied in a Xicor, Inc. product. No other circuits, patents, or licenses are implied.

### COPYRIGHTS AND TRADEMARKS

Xicor, Inc., the Xicor logo, E<sup>2</sup>POT, XDCC, XBGA, AUTOSTORE, Direct Write cell, Concurrent Read-Write, PASS, MPS, PushPOT, Block Lock, IdentiPROM, E<sup>2</sup>KEY, X24C16, SecureFlash, and SerialFlash are all trademarks or registered trademarks of Xicor, Inc. All other brand and product names mentioned herein are used for identification purposes only, and are trademarks or registered trademarks of their respective holders.

### U.S. PATENTS

Xicor products are covered by one or more of the following U.S. Patents: 4,326,134; 4,393,481; 4,404,475; 4,450,402; 4,486,769; 4,488,060; 4,520,461; 4,533,846; 4,599,706; 4,617,652; 4,668,932; 4,752,912; 4,829,482; 4,874,967; 4,883,976; 4,980,859; 5,012,132; 5,003,197; 5,023,694; 5,084,667; 5,153,880; 5,153,691; 5,161,137; 5,219,774; 5,270,927; 5,324,676; 5,434,396; 5,544,103; 5,587,573; 5,835,409; 5,977,585. Foreign patents and additional patents pending.

### LIFE RELATED POLICY

In situations where semiconductor component failure may endanger life, system designers using this product should design the system with appropriate error detection and correction, redundancy and back-up features to prevent such an occurrence.

Xicor's products are not authorized for use in critical components in life support devices or systems.

- Life support devices or systems are devices or systems which, (a) are intended for surgical implant into the body, or (b) support or sustain life, and whose failure to perform, when properly used in accordance with instructions for use provided in the labeling, can be reasonably expected to result in a significant injury to the user.
- A critical component is any component of a life support device or system whose failure to perform can be reasonably expected to cause the failure of the life support device or system, or to affect its safety or effectiveness.