

3.0A Positive Voltage Regulator

GENERAL DESCRIPTION

The XB1085 is a series of low dropout positive voltage regulators with a high output current capacity of 3.0A .

Stable output can be maintained by using 10 μ F (C_{IN}) and 22 μ F (C_L) of tantalum capacitors.

The fixed voltage types (XB1085P series) are available in 1.5V, 1.8V, 2.5V, 3.3V, and 5.0V. The voltage adjustable type (XB1085K series) is also available which can set the output voltage with only two external resistors.

With an overcurrent and thermal protection circuit built-in, the IC is disabled for protection when an output current reaches limit current or junction temperature increases up to limit temperature.

The XB1085 series is available in TO-252 package.

APPLICATIONS

- High efficiency linear regulators
- Battery chargers
- DVD drives
- Set top boxes
- Various battery drive equipment

FEATURES

Maximum Output Current	: More than 3.0A (within Pd)
Maximum Operating Voltage	: 12V
Output Voltage	: 1.5V, 1.8V, 2.5V, 3.3V, 5.0V, (XB1085P) Externally Set (XB1085K/ Reference Voltage 1.25V (TYP.))
Output Voltage Accuracy	: $\pm 1\%$ ($T_j = 25^\circ\text{C}$)
Dropout Voltage	: 1.3V @ $I_{OUT}=3.0\text{A}$ (TYP.)
Line Regulation	: 0.015% (TYP.) <ADJ>
Load Regulation	: 0.1% (TYP.) <ADJ>
Reference Voltage Pin Current	: Less than 120 μ A <ADJ>
Overcurrent Protection Circuit Built-In	
Thermal Protection Circuit Built-In	
Package	: TO-252
Environmentally Friendly	: EU RoHS Compliant

TYPICAL APPLICATION CIRCUITS

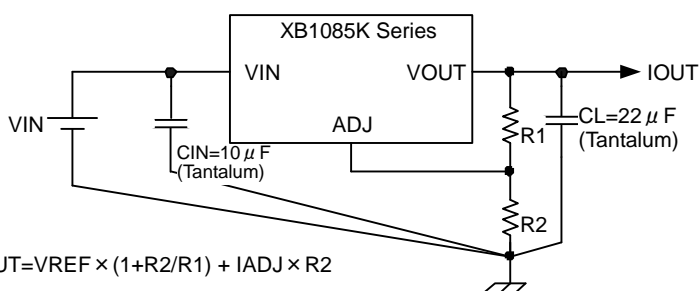
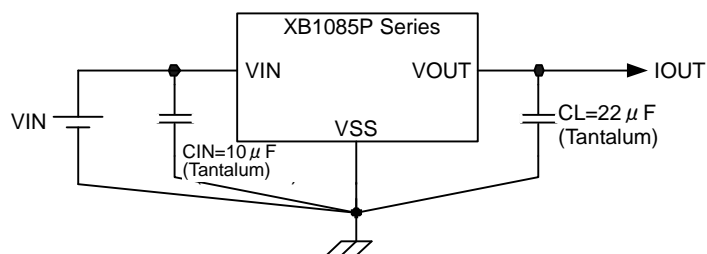

$$V_{OUT} = V_{REF} \times (1 + R_2/R_1) + I_{ADJ} \times R_2$$

TYPICAL PERFORMANCE CHARACTERISTICS

- Output Voltage vs. Output Current

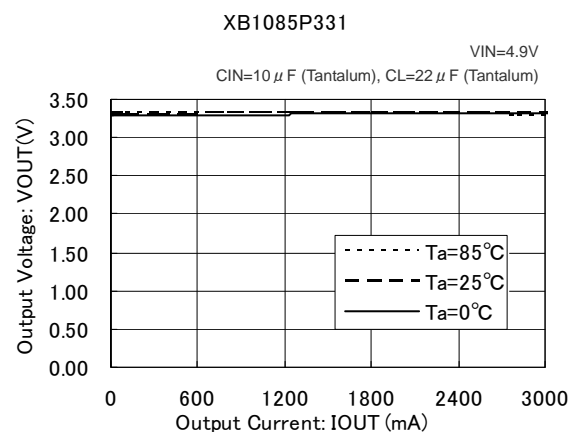

PIN CONFIGURATION

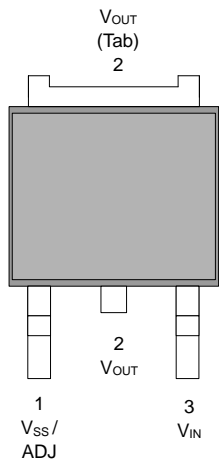

PIN ASSIGNMENT

PIN NUMBER	PIN NAME	FUNCTIONS
TO-252		
1	V _{SS} / ADJ	Ground / Reference Voltage
2	V _{OUT}	Output
3	V _{IN}	Input

PRODUCT CLASSIFICATION

Ordering Information

XB1085①②③④⑤⑥-⑦^(*)

DESIGNATOR	ITEM	SYMBOL	DESCRIPTION
①	Type of Regulators	P	Fixed V _{OUT}
		K	Adjustable (Externally Set)
②③④	Output Voltage (Output Voltage Accuracy)	151	V _{OUT} =1.5V (±1%)
		181	V _{OUT} =1.8V (±1%)
		251	V _{OUT} =2.5V (±1%)
		331	V _{OUT} =3.3V (±1%)
		501	V _{OUT} =5.0V (±1%)
	Output Voltage Externally Set (Output Voltage Accuracy)	12B	V _{OUT} =1.25V (±1%)
⑤⑥-⑦	Package (Order Unit)	JR	TO-252 (2,500/Reel)
		JR-G	TO-252 (2,500/Reel)

^(*) The "-G" suffix denotes Halogen and Antimony free as well as being fully EU RoHS compliant.

■ BLOCK DIAGRAM

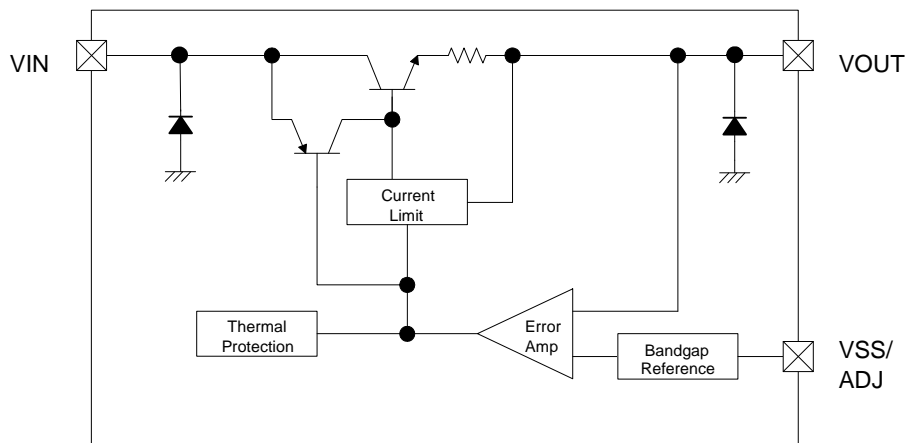

*Diodes inside the circuit are ESD protection diodes.

■ ABSOLUTE MAXIMUM RATINGS

Ta=25°C

PARAMETER	SYMBOL	RATINGS	UNIT
Input Voltage	V _{IN}	18	V
Power Dissipation	P _d	1300 ^(*2)	mW
Operating Junction Temperature	T _j	125	°C
Storage Temperature	T _{stg}	- 55 ~ +125	°C

Note:

(*1) Stresses greater than those listed above ratings may cause permanent damage to the device.

(*2) The rating of the power dissipation is determined when mounted on the PCB.

ELECTRICAL CHARACTERISTICS

XB1085PxxxJR

Ta=25°C

PARAMETER	SYMBOL	CONDITIONS	MIN.	TYP.	MAX.	UNIT	CIRCUIT	
Output Voltage	V _{OUT} (1.5V)	V _{IN} =4.5V, I _{OUT} =0mA		1.485	1.5	1.515	V	①
			O.T. ^(*)	1.47		1.53		
	V _{OUT} (1.8V)	V _{IN} =4.8V, I _{OUT} =0mA		1.782	1.8	1.818	V	①
			O.T. ^(*)	1.764		1.836		
	V _{OUT} (2.5V)	V _{IN} =5.5V, I _{OUT} =0mA		2.475	2.5	2.525	V	①
O.T. ^(*)			2.450	-	2.550			
V _{OUT} (3.3V)	V _{IN} =6.3V, I _{OUT} =0mA		3.267	3.3	3.333	V	①	
		O.T. ^(*)	3.234	-	3.366			
V _{OUT} (5.0V)	V _{IN} =8.0V, I _{OUT} =0mA		4.95	5	5.05	V	①	
		O.T. ^(*)	4.9		5.1			
Line Regulation	ΔV _{OUT1} (1.5V)	3.0V ≤ V _{IN} ≤ 10V I _{OUT} =10mA		-	0.5	6	mV	①
			O.T. ^(*)		1	6		
	ΔV _{OUT1} (1.8V)	3.3V ≤ V _{IN} ≤ 10V I _{OUT} =10mA		-	0.5	6	mV	①
			O.T. ^(*)		1	6		
	ΔV _{OUT1} (2.5V)	4.0V ≤ V _{IN} ≤ 10V I _{OUT} =10mA		-	0.5	6	mV	①
O.T. ^(*)				1	6			
ΔV _{OUT1} (3.3V)	4.8V ≤ V _{IN} ≤ 10V I _{OUT} =10mA		-	0.5	6	mV	①	
		O.T. ^(*)		1	6			
ΔV _{OUT1} (5.0V)	6.5V ≤ V _{IN} ≤ 10V I _{OUT} =10mA		-	0.5	10	mV	①	
		O.T. ^(*)		1	10			
Load Regulation	ΔV _{OUT2} (1.5V)	V _{IN} -V _{OUT} =3.0V 0mA ≤ I _{OUT} ≤ 3.0A		-	3	15	mV	①
			O.T. ^(*)		7	20		
	ΔV _{OUT2} (1.8V)	V _{IN} -V _{OUT} =3.0V 0mA ≤ I _{OUT} ≤ 3.0A		-	3	15	mV	①
			O.T. ^(*)		7	20		
	ΔV _{OUT2} (2.5V)	V _{IN} -V _{OUT} =3.0V 0mA ≤ I _{OUT} ≤ 3.0A		-	3	15	mV	①
O.T. ^(*)				7	20			
ΔV _{OUT2} (3.3V)	V _{IN} -V _{OUT} =3.0V 0mA ≤ I _{OUT} ≤ 3.0A		-	3	15	mV	①	
		O.T. ^(*)		7	20			
ΔV _{OUT2} (5.0V)	V _{IN} -V _{OUT} =3.0V 0mA ≤ I _{OUT} ≤ 3.0A		-	5	20	mV	①	
		O.T. ^(*)		10	35			
Dropout Voltage	V _{dif}	ΔV _{OUT} =1%, I _{OUT} =3.0A	-	1.3	1.5	V	①	
Limit Current	I _{LIM}	V _{IN} -V _{OUT} =3.0V	3.2	4.5	-	A	①	
Supply Current	I _{DD}	V _{IN} =10V	O.T. ^(*)	-	5	10	mA	②
Temperature Stability	T _s	V _{IN} -V _{OUT} =1.5V I _{OUT} =10mA	O.T. ^(*)	-	0.5	-	%	-

Note:

(*) O.T. denotes the specifications which apply over the operating junction Temperature range (0°C ≤ T_j ≤ 125°C).

Please be sure that the power consumption does not exceed the power dissipation rating 1300mW. If the power consumption exceeds the power dissipation rating and the operating junction temperature rises more than the rating 125°C, the IC enters thermal shutdown state.

■ ELECTRICAL CHARACTERISTICS (Continued)

XB1085K12BJR

Ta=25°C

PARAMETER	SYMBOL	CONDITIONS	MIN.	TYP.	MAX.	UNIT	CIRCUIT
Reference Voltage	V _{REF}	V _{IN} -V _{OUT} =3.0V	1.238	1.25	1.262	V	③
		I _{OUT} =10mA	O.T. ^(*) 1.225	-	1.275		
Line Regulation	ΔV _{OUT1}	2.85V ≤ V _{IN} ≤ 10V	-	0.015	0.2	%	③
		I _{OUT} =10mA	O.T. ^(*)	0.035	0.2		
Load Regulation	ΔV _{OUT2}	V _{IN} -V _{OUT} =3.0V	-	0.1	0.3	%	③
		0mA ≤ I _{OUT} ≤ 3.0A	O.T. ^(*)	0.2	0.4		
Dropout Voltage	V _{dif}	ΔV _{OUT} =1%, I _{OUT} =3.0A	-	1.3	1.5	V	③
Limit Current	I _{LIM}	V _{IN} -V _{OUT} =3.0V	3.2	4.5	-	A	③
Temperature Stability	T _s	V _{IN} -V _{OUT} =1.5V I _{OUT} =10mA	O.T. ^(*) -	0.5	-	%	-
Minimum Output Current	I _{OUTmin}	V _{IN} =10V	O.T. ^(*) -	3	10	mA	③
Adjust Voltage Pin Current	I _{ADJ}	V _{IN} =4.25V, I _{OUT} =10mA	O.T. ^(*) -	55	120	μA	③

Note:

(*1) O.T. denotes the specifications which apply over the operating junction Temperature range (0°C ≤ T_j ≤ 125°C).

Please be sure that the power consumption does not exceed the power dissipation rating, 1300mW. If the power consumption exceeds the power dissipation rating and the operating junction temperature rises more than the rating, 125°C, the IC enters thermal shutdown state.

■ OUTPUT VOLTAGE ADJUSTMENT

With the adjustable XB1085K12BJR, a 1.25V reference voltage is fixed between the V_{OUT} pin and the ADJ pin and the external resistors R1 and R2 are used to set the output voltage.

Please set it so that an electric current (I_{R1}) flowing through R1 is as above 10mA.

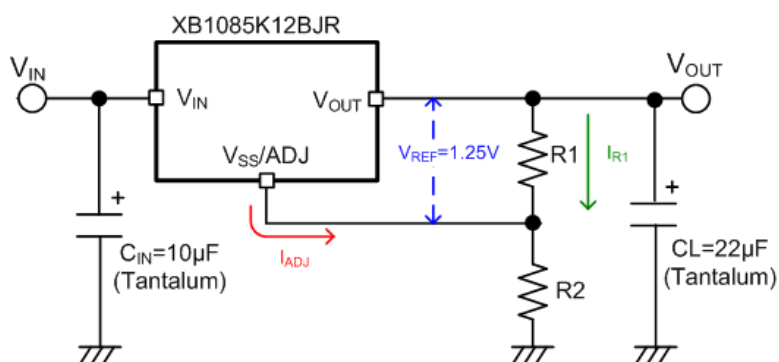

The output voltage is given by the following equation.

$$V_{OUT} = V_{REF} \times \left(1 + \frac{R2}{R1}\right) + I_{ADJ} \times R2$$

$$R2 = \frac{R1 \times (V_{OUT} - V_{REF})}{V_{REF} + I_{ADJ} \times R1}$$

TEST CIRCUITS

< Circuit ① >

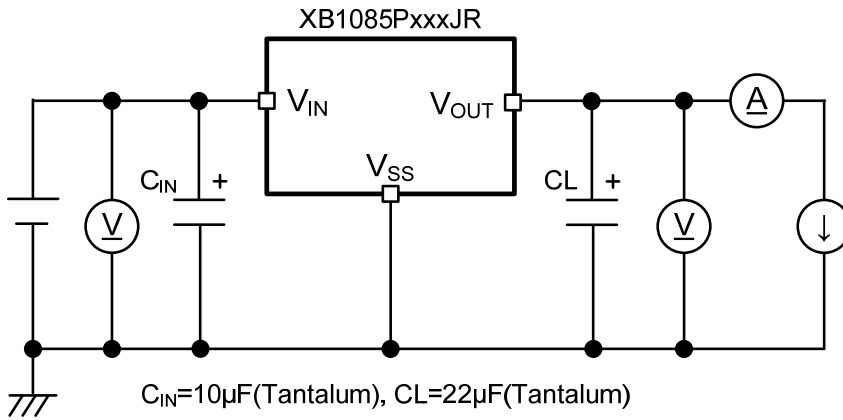

< Circuit ② >

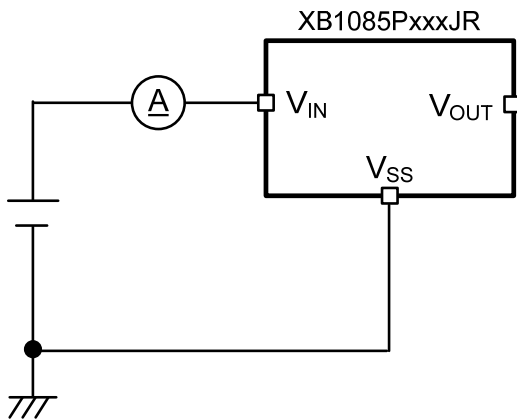

< Circuit ③ >

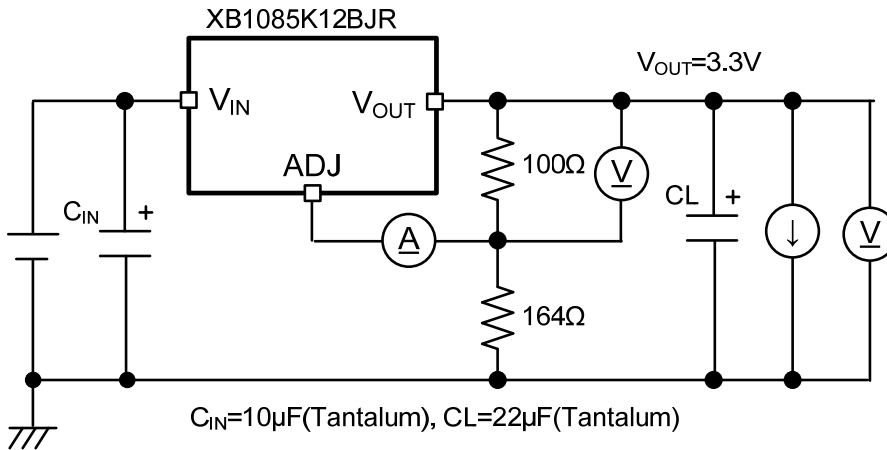

■ NOTES ON USE

1. For temporary, transitional voltage drop or voltage rising phenomenon, the IC is liable to malfunction should the ratings be exceeded.
2. Where wiring impedance is high, operations may become unstable due to the noise and/or phase lag depending on output current. Please strengthen V_{IN} and V_{SS} wiring in particular.
3. The input capacitor (C_{IN}) and the output capacitor (C_L) should be placed to the IC as close as possible with a shorter wiring.
4. Torex places an importance on improving our products and its reliability. However, by any possibility, we would request user fail-safe design and post-aging treatment on system or equipment.

TYPICAL PERFORMANCE CHARACTERISTICS

(1) Output Voltage vs. Output Current

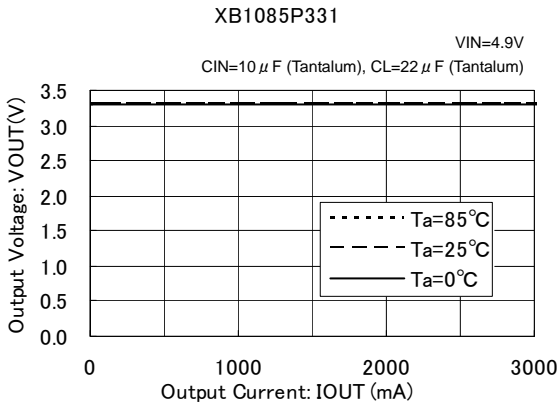

(2) Output Voltage vs. Input Voltage

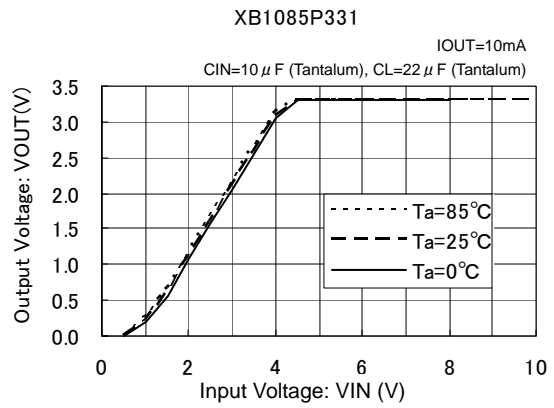

(3) Dropout Voltage vs. Output Current

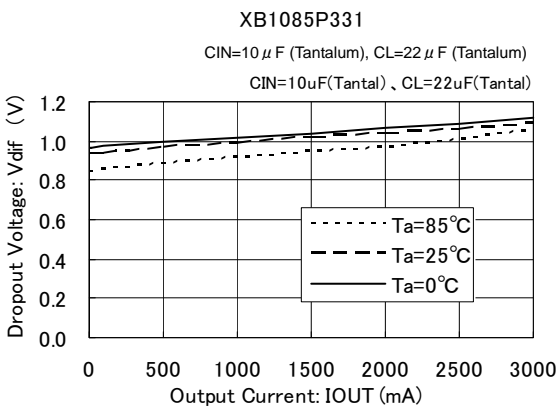

(4) Supply Current vs. Input Voltage

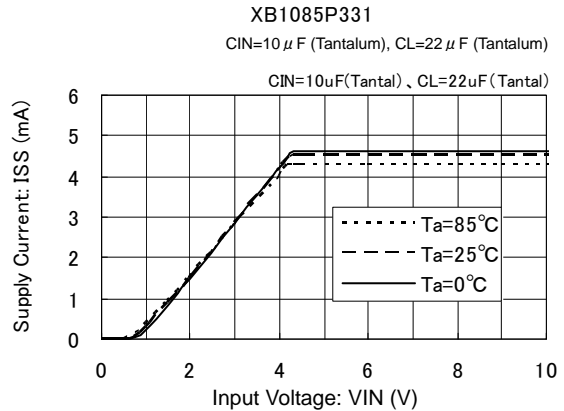

(5) Reference Voltage vs. Ambient Temperature

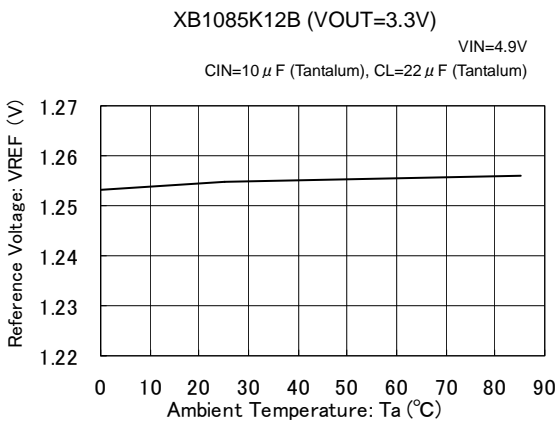

(6) Adjust Pin Current vs. Ambient Temperature

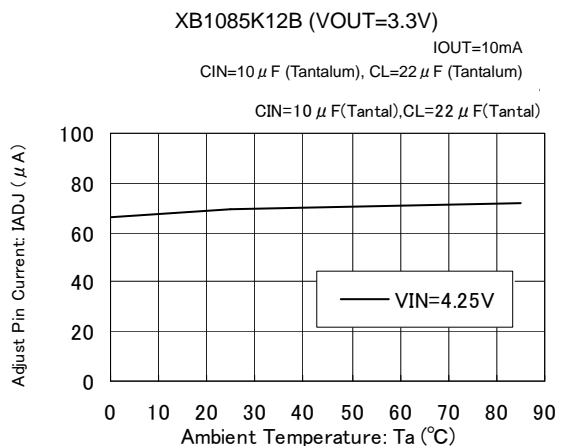

TYPICAL PERFORMANCE CHARACTERISTICS (Continued)

(7) Load Transient Response

XB1085P331

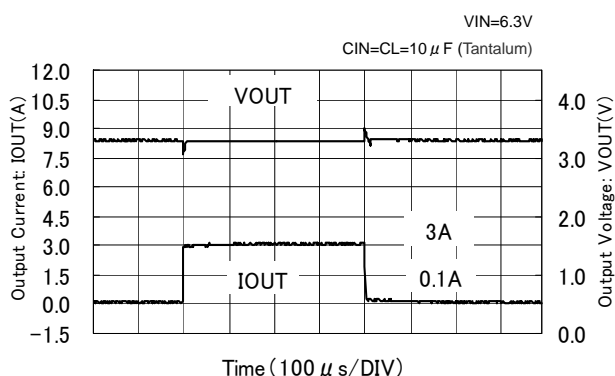

XB1085K12B(VOUT=3.3V)

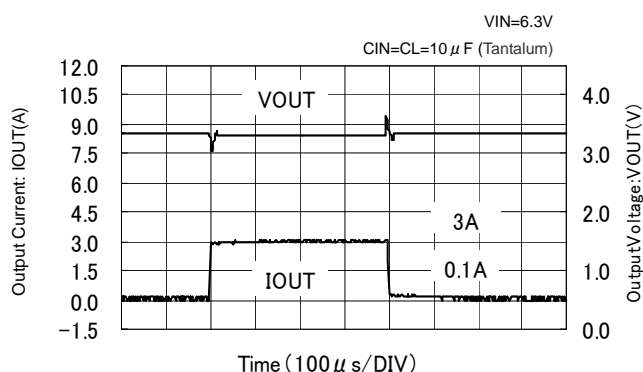

(8) Input Transient Response

XB1085P331

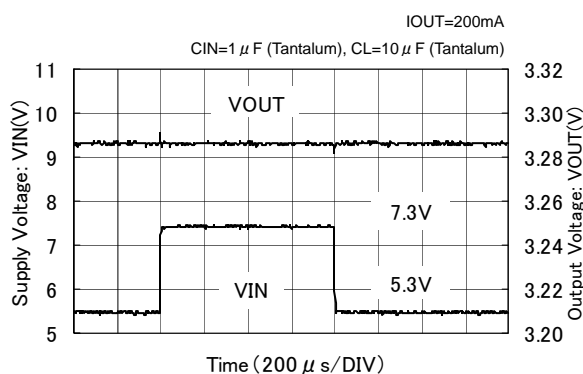

XB1085K12B(VOUT=3.3V)

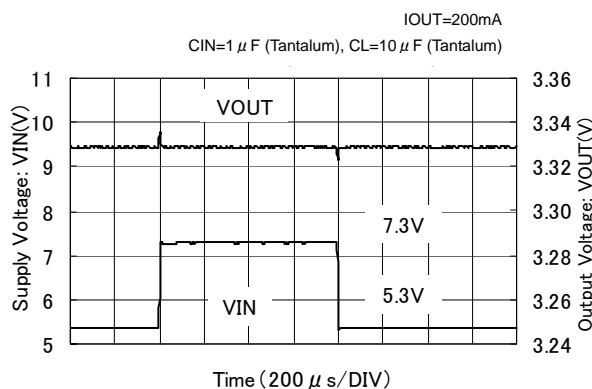

(9) Ripple Rejection Rate

XB1085P331

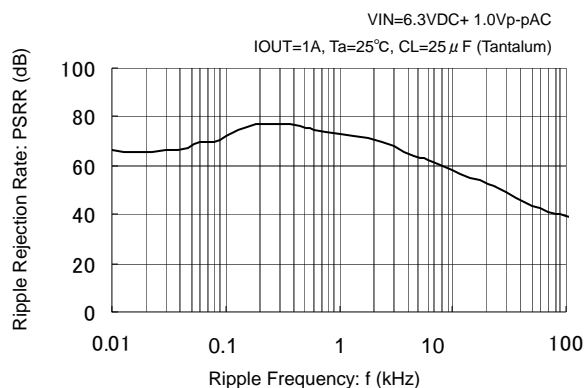

XB1085K12B(VOUT=3.3V)

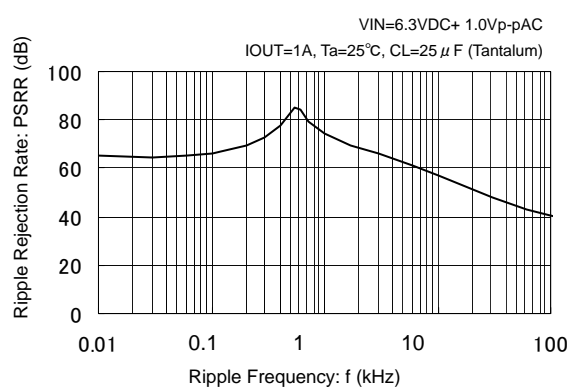

PACKAGING INFORMATION

● TO-252

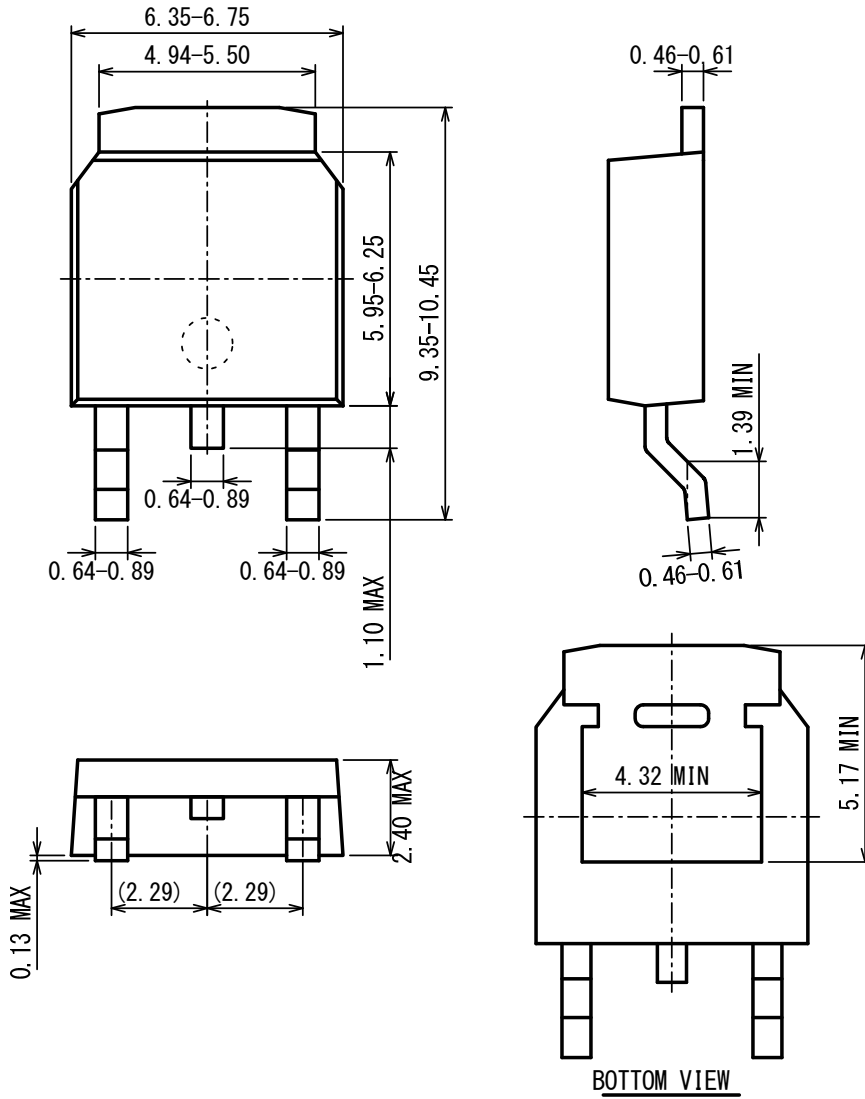

UNIT: mm

MARKING RULE

● TO-252

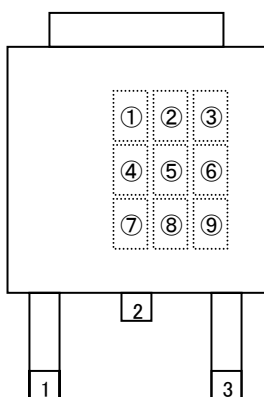

TO-252
(TOP VIEW)

(mark header : ①~⑥) *Mark header does not change with a lot.

①② represents product series

MARK		PRODUCT SERIES
①	②	
8	5	XB1085****J*

③ represent the type of regulator

MARK	TYPE	PRODUCT SERIES
P	Fixed Output Type	XB1085P***J*
K	Adjustable (Externally Set)	XB1085K***J*

④⑤ represents output voltage

MARK		OUTPUT VOLTAGE	PRODUCT SERIES
④	⑤		
1	5	1.5V	XB1085P151J*
1	8	1.8V	XB1085P181J*
2	5	2.5V	XB1085P251J*
3	3	3.3V	XB1085P331J*
5	0	5.0V	XB1085P501J*
1	2	ADJ	XB1082K12BJ*

⑥ represents output voltage accuracy and output type

MARK	OUTPUT VOLTAGE ACCURACY (OUTPUT TYPE)	PRODUCT SERIES
1	1%	XB1085P**1J*
B	Adjustable	XB1085K12BJ*

⑦ represents the last digit of production year
ex.)

MARK	PRODUCTION YEAR
7	2007
8	2008

⑧⑨ represents production lot number

0 to 9, A to Z repeated.

(G, I, J, O, Q, W excepted. '0' of the first digit does not mark.)

* No character inversion used.

ex.)

MARK		PRODUCTION LOT NUMBER
⑧	⑨	
Blank	3	03
1	A	1A

1. The products and product specifications contained herein are subject to change without notice to improve performance characteristics. Consult us, or our representatives before use, to confirm that the information in this datasheet is up to date.
2. We assume no responsibility for any infringement of patents, patent rights, or other rights arising from the use of any information and circuitry in this datasheet.
3. Please ensure suitable shipping controls (including fail-safe designs and aging protection) are in force for equipment employing products listed in this datasheet.
4. The products in this datasheet are not developed, designed, or approved for use with such equipment whose failure or malfunction can be reasonably expected to directly endanger the life of, or cause significant injury to, the user.
(e.g. Atomic energy; aerospace; transport; combustion and associated safety equipment thereof.)
5. Please use the products listed in this datasheet within the specified ranges.
Should you wish to use the products under conditions exceeding the specifications, please consult us or our representatives.
6. We assume no responsibility for damage or loss due to abnormal use.
7. All rights reserved. No part of this datasheet may be copied or reproduced without the prior permission of TOREX SEMICONDUCTOR LTD.

TOREX SEMICONDUCTOR LTD.